

The KMLF is ideal for handling low flow applications involving corrosives and acidic substances as they relate to the chemical, specialty chemical and steel industries.



# KMLF Low Flow

## Sealless Magnetic Drive Pump



The KMLF is a sealless magnetic drive, non-metallic centrifugal end suction pump built to comply with ASME / ANSI B73.3 standards and suitable for chemical processing duty.

The KMLF delivers:

- Flows to: 40 GPM (9 m<sup>3</sup> / hr)
- Total Dynamic Head: 170 ft (52 m)

Simple by design, Sundyne Ansimag pumps deliver world class performance in a remarkably compact footprint. With no seals or mechanical couplings to leak or fail, these pumps are the safest choice for those looking to protect personnel and the environment. Additionally, Sundyne sealless pumps feature fewer wetted parts than competitive products and a powder coat finish to prevent corrosion, delivering enhanced durability, optimal reliability and lower through-life costs over traditional sealed pumps. Built to meet exacting ASME / ANSI B73.3 chemical process pump standards, Sundyne sealless pumps are dimensionally interchangeable and represent the easy upgrade option from standard mechanically sealed pumps.

### Specifications

Heads To	10 to 170ft	3 to 52m	60HZ: 3 to 52m
Flows To	1 to 40gpm	.23 to 9m <sup>3</sup> /hr	
Max Power	1 to 7.5hp	1 to 5.5kW	
Temp Range	-20 to 250°F	-29 to 121°C	
Number of Stages	1		
Max Case Working Pressure	150 psi	10.3 bar	
Standard Delivery	2 Weeks		
Materials of Construction	Carbon Fiber Reinforced ETFE		
Bearing Materials Available	Silicon Carbide (Standard) Carbon Graphite (Optional)		
Hydrotest Pressure	225 psig	15.45 bar	
Max Viscosity	700 SSU (150 centistokes)		
Solids Range	Concentration to 3% w/w Size: 1/16" (1.6mm) Diameter		
Motor Details	NEMA C-face and IEC B5		
Mounting Configurations	Horizontal close coupled		
Number of Available Hydraulics...	1		
Seal Configurations Available	Sealless		
Available Flanges	Universal Flange fits ANSI Class 150, ISO PN16, and JIS 10 kg/cm <sup>2</sup>		

### APPLICATIONS

- Ethanol
- Solvents
- Plastics
- Specialty Chemicals
- Aromatics
- Corrosive Services
- Metal Pickling
- Plating
- Acid Transfer
- Flammable Liquids

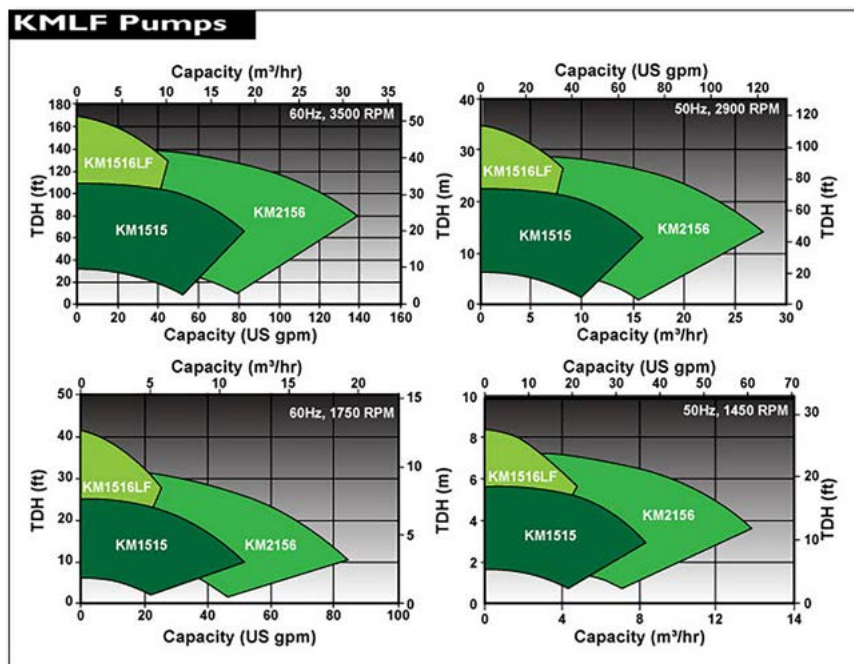
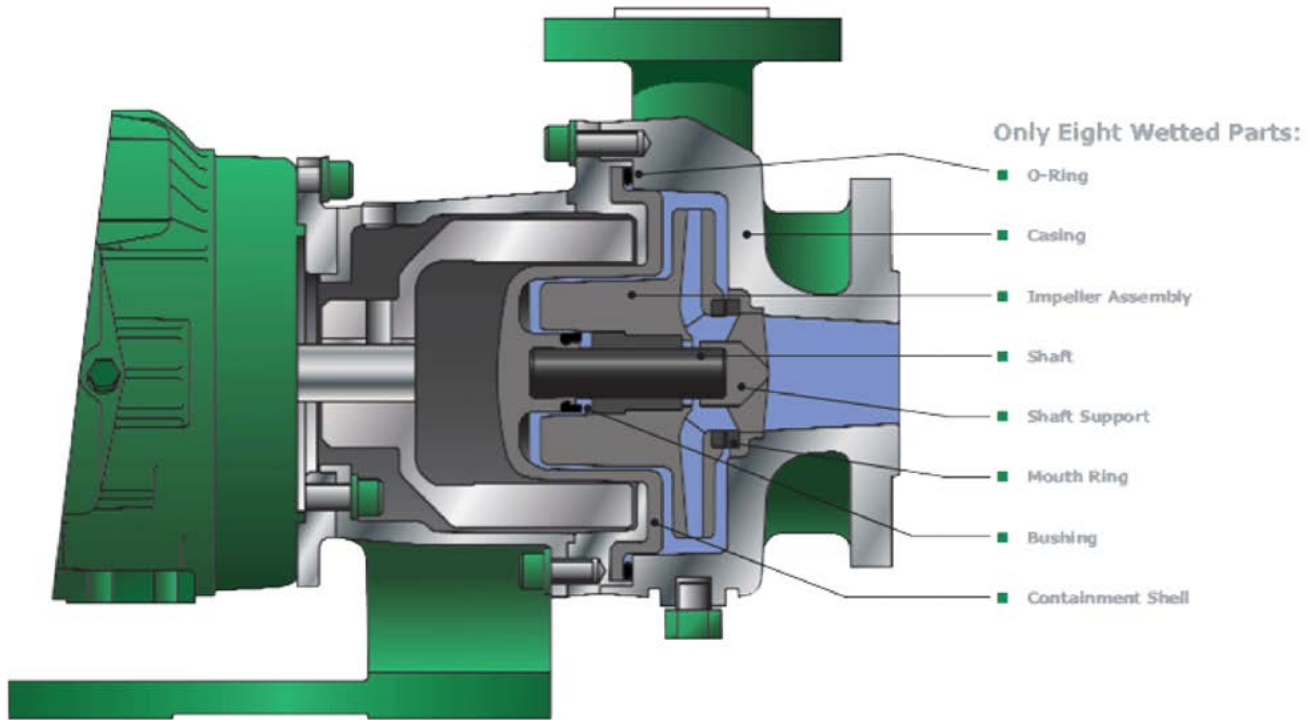

AUSTRALIAN DISTRIBUTOR



CALL 1300 789 466  
 When Pump Knowledge Matters  
[www.kelairpumps.com.au](http://www.kelairpumps.com.au)