

With ASME / ANSI compliant dimensions, the KV is perfect for handling corrosive and acidic substances in the CPI, specialty chemical and steel industries.



# KV

## Sealless Magnetic Drive Pump



The KV is a sealless magnetic drive, non-metallic centrifugal pump. Featuring a vertical configuration, the KV is perfect for fulfilling processes with limited space requirements.

The KV delivers:

- Flows to: 325 GPM (74 m<sup>3</sup> / hr)
- Total Dynamic Head: 325 ft (99 m)

Simple by design, Sundyne Ansimag pumps deliver world class performance in a remarkably compact footprint. With no seals or mechanical couplings to leak or fail, these pumps are the safest choice for those looking to protect personnel and the environment. Additionally, Sundyne sealless pumps feature fewer wetted parts than competitive products and a powder coat finish to prevent corrosion, delivering enhanced durability, optimal reliability and lower through-life costs over traditional sealed pumps. Built to meet exacting ASME / ANSI B73.3 chemical process pump standards, Sundyne sealless pumps are dimensionally interchangeable and represent the easy upgrade option from standard mechanically sealed pumps.

### Specifications

Heads To	40 to 325ft	8 to 69m	60HZ: 12 to 99m
Flows To	1 to 325gpm	8 to 59m <sup>3</sup> /hr	60HZ: 10 to 74m <sup>3</sup> /hr
Max Power	30	22	
Temp Range	-20 to 250°F	-30 to 120°C	
Number of Stages	1.0		
Max Case Working Pressure	285 psi	19.3 kg/cm <sup>2</sup>	
Standard Delivery	3 Weeks		
Materials of Construction	Carbon Fiber Reinforced ETFE		
Bearing Materials Available	Silicon Carbide Carbon Graphite		
Hydrotest Pressure	430 psi	30 kg/cm <sup>2</sup>	
Max Viscosity	1,200 SSU (260 centistokes)		
Industry Standard	ANSI		
Solids Range	to 40%		
Motor Details	NEMA IEC		
Mounting Configurations	Vertical close coupled		
Dimensional Standards	ANSI B73.2		
Number of Available Hydraulics...	3.0		
Seal Configurations Available	Sealless		
Available Flanges	ANSI Class 150 RF ANSI Class 300 RF ISO PN16 JIS 10		

### APPLICATIONS

- Offshore
- Water Treatment
- Chemical Processing
- Corrosive Services
- Bulk Chemicals
- Acid Transfer
- Toxic Services
- Agrochemicals
- Aromatics
- Metal Pickling

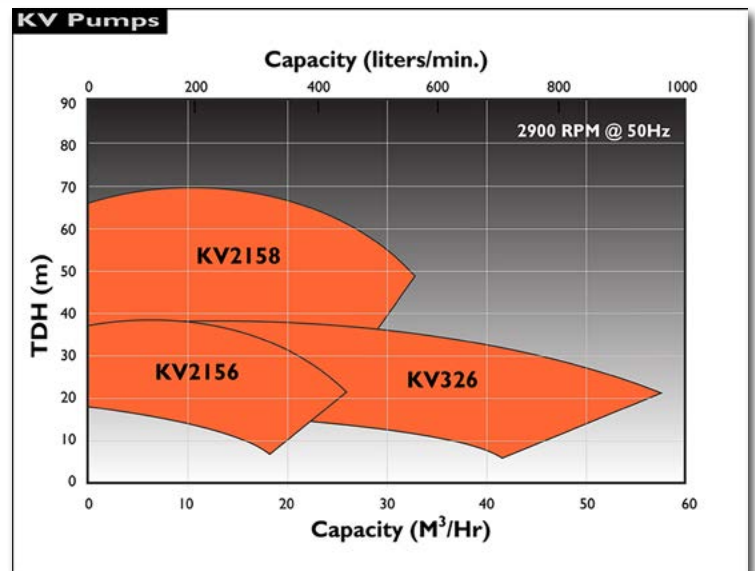
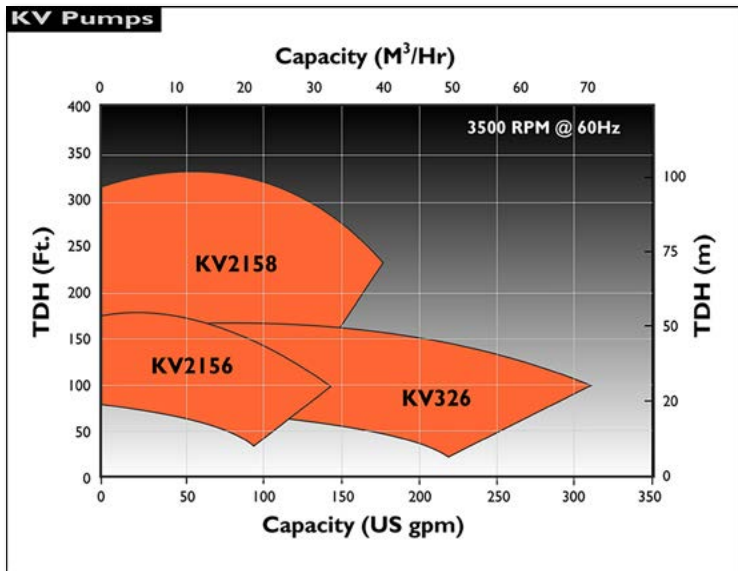
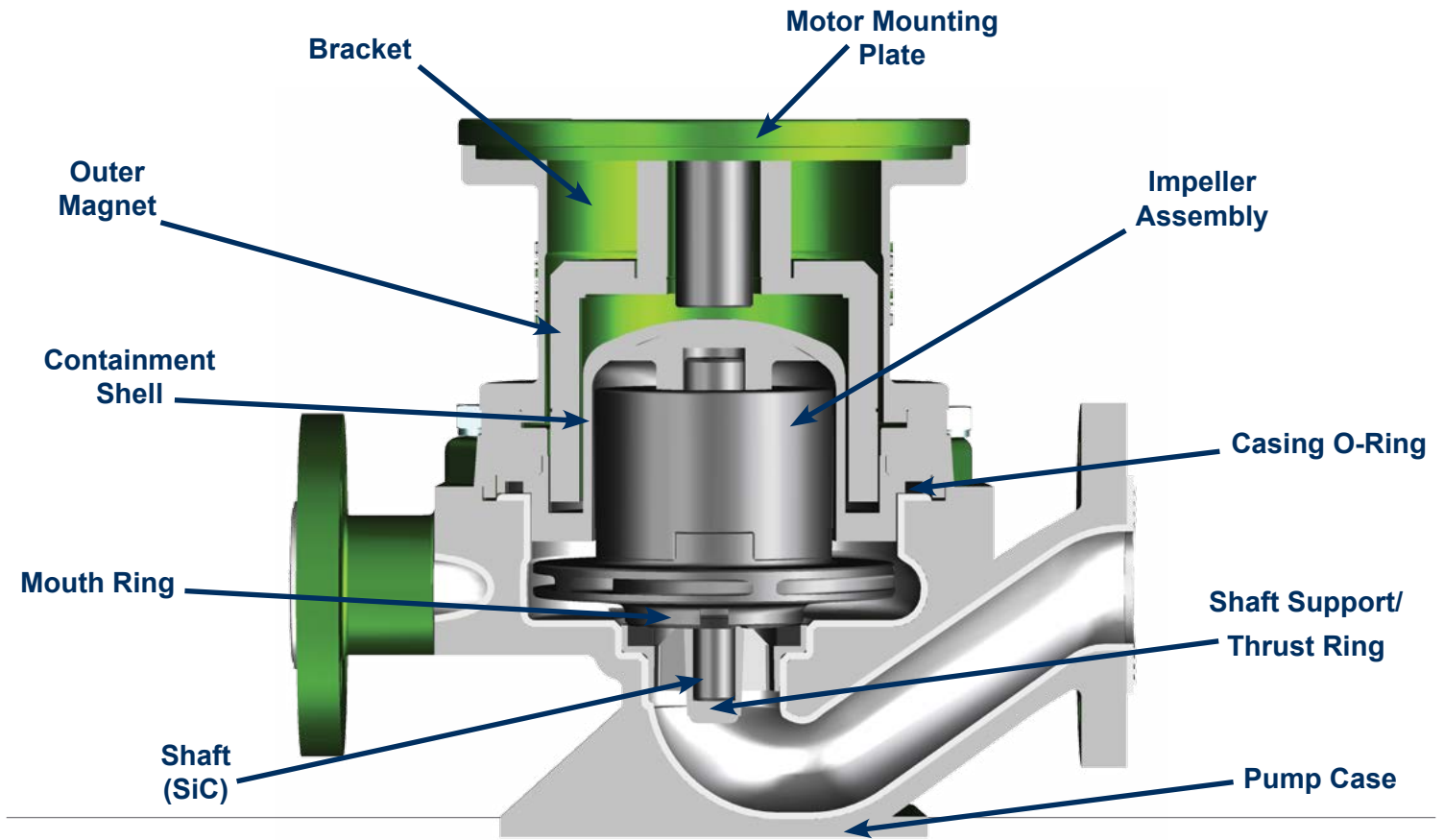

AUSTRALIAN DISTRIBUTOR



CALL 1300 789 466

When Pump Knowledge Matters  
[www.kelairpumps.com.au](http://www.kelairpumps.com.au)