

SC-Series

Multistage Side Channel Pumps

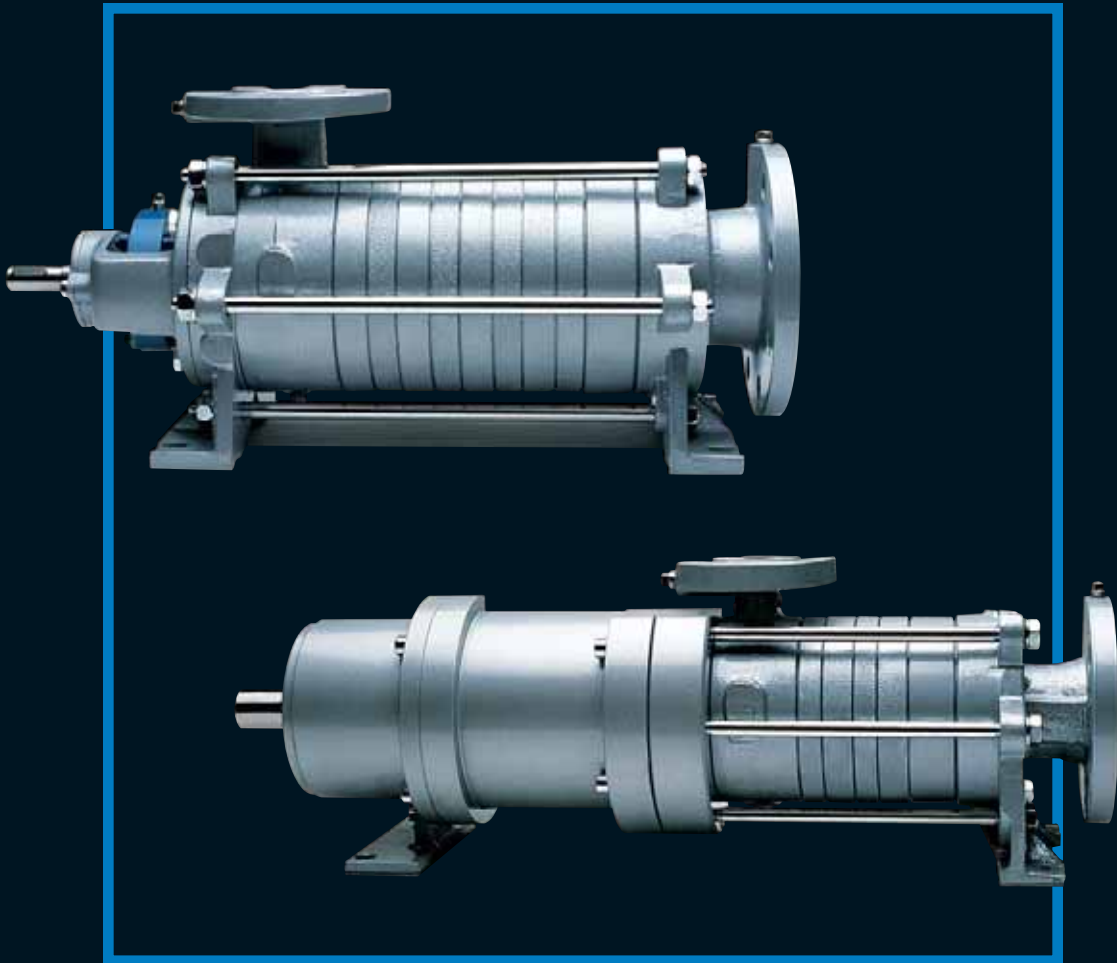

Solutions beyond products...

CORKEN[®]
IBEX

SC-Series

Multistage Pump

Higher differential pressure and aerated liquids

Corken presents the most recent addition to its liquid transfer offering, the new side channel (SC) pump line. The integral centrifugal and side channel design which characterizes this line provides you with a new dimension in liquid transfer applications. The SC-Series exceeds expectations in the handling of liquids involving high differential pressures, low NPSH conditions, and aerated liquids up to 50% gas. Corken is recognized as a world leader in the manufacture of vane and turbine type pumps and low horsepower oil free compressors for hazardous, volatile and toxic liquids and gases.

Six different sizes, each ranging from one to eight stages provide solutions for a wide range of pressures, capacities, and liquid transfer requirements. Multiple material and sealing options, enabling it to handle many different liquids, enhances the versatility of the SC-Series.

Whether it is utilized in common applications such as LPG cylinder filling or in specialized applications involving corrosive chemicals, the Corken SC pump is the right choice for long lasting, proven performance.

Multistage side channel design delivers higher differential pressures...

The Corken SC pump line utilizes an integral centrifugal and side channel design to create the flow characteristics that make this pump special. The high differential pressure and self priming capabilities are results of the multistage side channel design. This feature incorporates one to eight stages of open radial vane impellers and their special modular side channel casing.

Quiet, smooth transfer even at low NPSH...

The SC pump's ability to handle low NPSH applications is attributed to the proprietary centrifugal impeller design near the pump inlet. The SC pump is cylindrical in shape with liquid flow entering the pump horizontally (parallel with the pump shaft) and exiting vertically through the discharge flange on the top of the pump.

Many sealing options to choose from, including magnetic drive...

In a time when leakage control is becoming more and more prevalent, Corken offers a complete range of seal options. Whether your application calls for packing, mechanical seals (single or double), or even sealless designs, the SC pump will meet your needs.

Corken also offers the side channel magnetic drive (SCM) sealless multistage pump which meets the most stringent environmental regulations. The SCM line retains all of the advantages of the standard SC design along with two additional advantages; there are no seals to maintain and no potential leak paths.

Multiple material options for impellers and casing:
Enables the pump to handle a wide variety of liquid applications.

Proprietary centrifugal impeller design: Ensures efficient transfer even at low NPSH conditions.

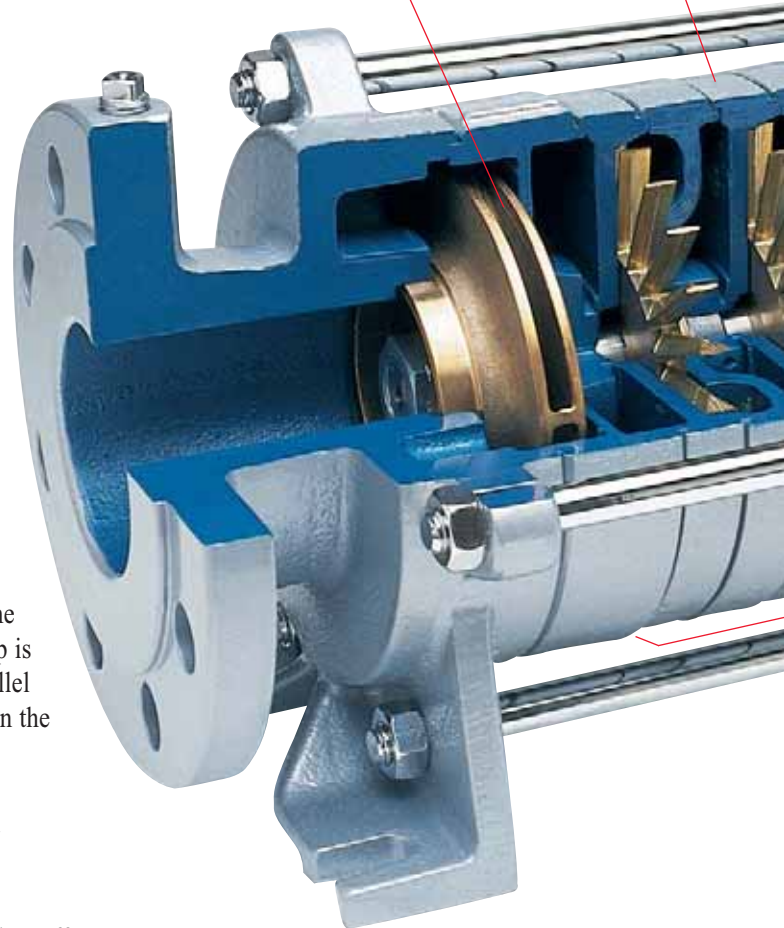

Pressures, lower NPSH values, —all with one pump...

Multiple material options available.

Both the SC and SCM lines come with multiple material options in order to handle a variety of liquids. Casing material options of cast iron, ductile iron, or stainless steel and impeller options of brass, steel, or stainless steel contribute to this pump's versatility in the handling of highly corrosive liquids and extreme pressure conditions.

Applications

- Cylinder filling
- Lift from underground tanks
- Truck filling
- Vaporizer feeding
- General transfer
- Refrigerant transfer
- Aerosol charging
- Chemical transfer
- Boiler feed

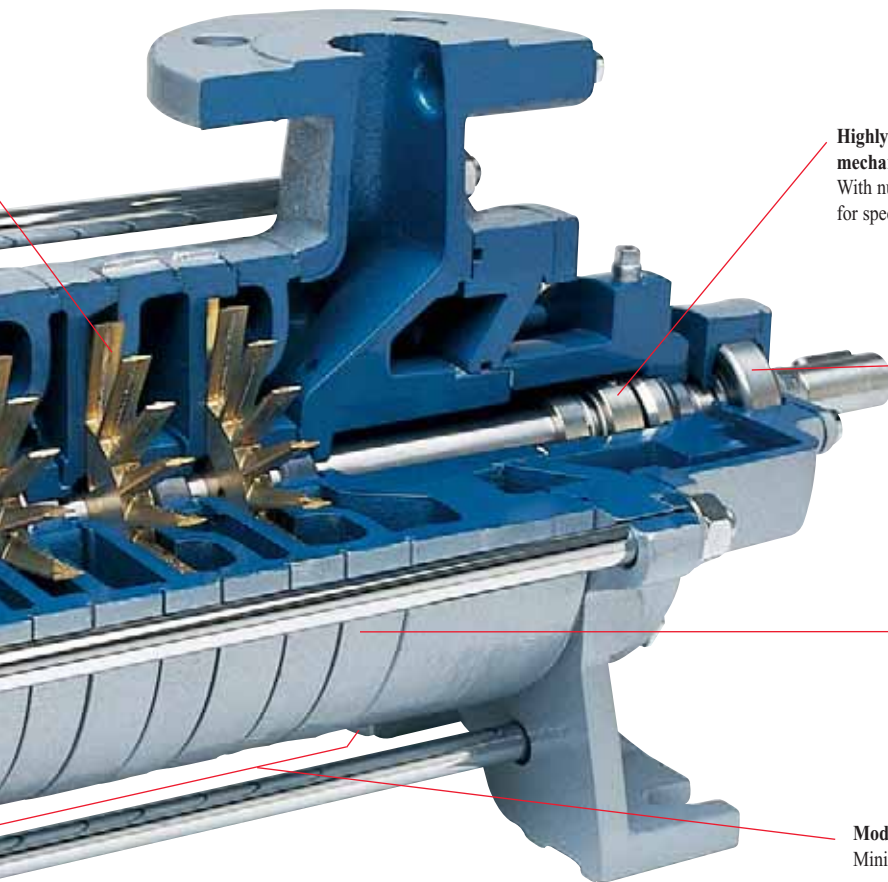

Highly reliable single mechanical seals standard:
With numerous seal options for special applications.

Heavy duty bearings standard:
With optional bearing configurations, extra clearance options, and special cooling connections for high temperature service.

Multiple side channel stages:
Provide self-priming, high differential pressure, non-pulsating, trouble free operation.

Modular construction:
Minimizes spare parts requirements.

Unique design minimizes maintenance.

The impellers within the SC-Series are free floating which means there is no metal to metal contact and as a result, fewer wear parts. This feature minimizes maintenance and provides years of reliable trouble free service.

SC-Series is backed by the strongest service commitment in the industry.

Corken has been built upon decades of maintaining the highest quality. With a total commitment to customer service, Corken provides complete factory technical support as well as field training. In addition, Corken products are backed by a world wide network of distributors.

QUALITY
ISO 9001
SYSTEM

ENVIRONMENTAL
ISO 14001
MANAGEMENT
SYSTEM

Solutions beyond products...

CORKEN

SERIES NUMBER	10	20	30	40	50	60
NUMBER OF STAGES	1 TO 8					
INLET FLANGE in (mm)	1½ (40)	2½ (65)	2½ (65)	3 (80)	4 (100)	4 (100)
OUTLET FLANGE in (mm)	¾ (20)	1¼ (32)	1¼ (32)	1½ (40)	2 (50)	2½ (65)
RPM (60Hz) RPM (50Hz)	1150, 1750 1450					
MAXIMUM WORKING PRESSURE psi (bar)	580 (40)					
DIFFERENTIAL RANGE HEAD ft (m)	50 (15)– 690 (210)	65 (20)– 1050 (320)	30 (10)– 820 (250)	30 (10)– 805 (245)	30 (10)– 950 (290)	30 (10)– 1150 (350)
MINIMUM TEMPERATURE °F (°C)	-40° (-40°)					
MAXIMUM TEMPERATURE °F (°C)	430° (220°)					
NPSH _R RANGE ft (m)	1.6 (.5)– 13 (4)	2 (.6)– 3.3 (1)	1.6 (.5)– 6.6 (2)	1.3 (.4)– 8.2 (2.5)	1.3 (.4)– 12 (3.5)	4.6 (1.4)– 8.2 (2.5)
MAXIMUM VISCOSITY SSU (cSt)	1050 (230)					
MAXIMUM PROPORTION OF GAS ALLOWABLE	50%					

Options (For all series)

Casing Material: Impeller Material:

- Cast iron
- Ductile iron
- Stainless steel
- Brass
- Steel
- Stainless steel

Sealing Options:

- Packing glands–balanced, unbalanced and external flush
- Single mechanical seal–balanced, unbalanced and quench option
- Double mechanical seal–balanced and unbalanced

High Temperature Options:

- Increased clearance
- High temperature bearings
- Cooling connections

1150 RPM

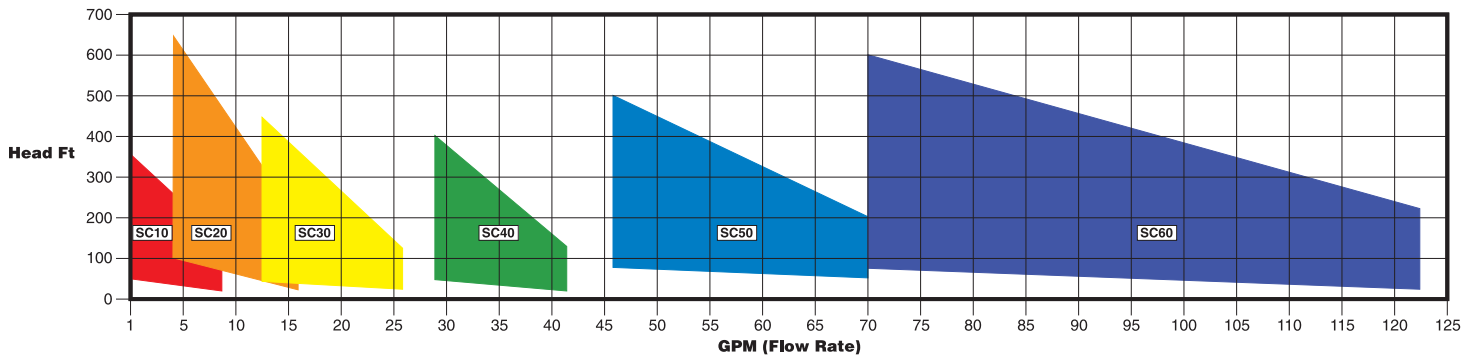

1450 RPM

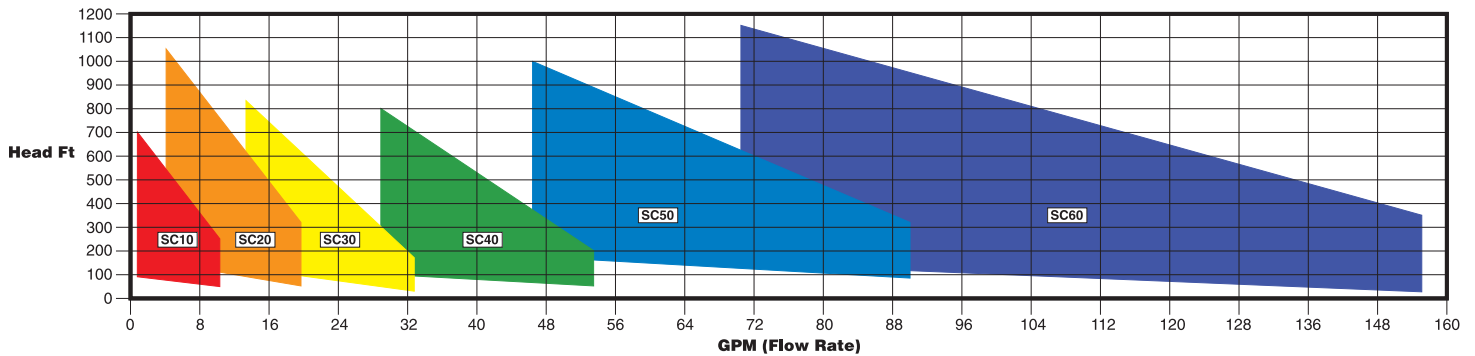

1750 RPM

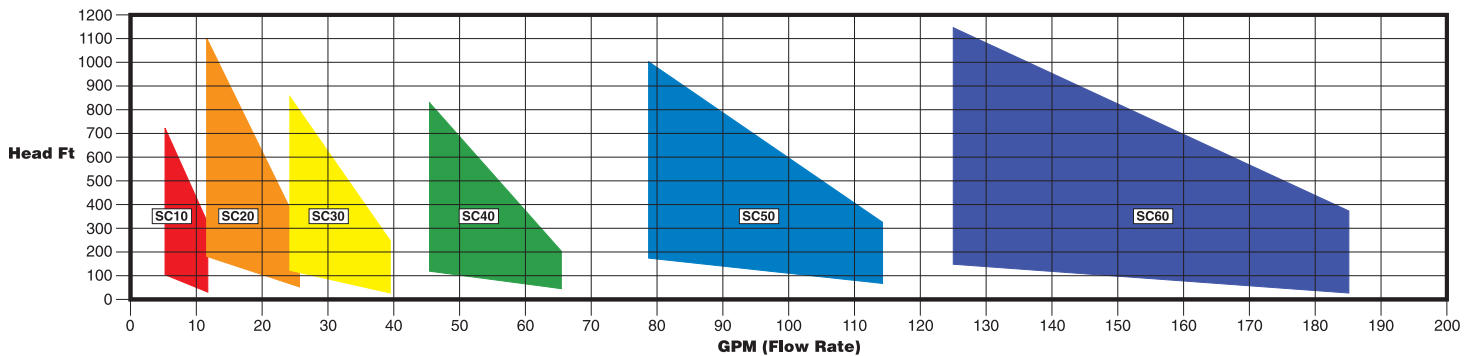

Solutions beyond products...

CORKEN
IBEX

AUSTRALIAN DISTRIBUTOR



KelairPumps

CALL 1300 789 466

When Pump Knowledge Matters

www.kelairpumps.com.au