

Grundfos CRN MAGdrive

Leak-free pumps for hazardous media

Need to pump dangerous, aggressive, volatile or precious media? Then what you really want is a completely leak-free pump. Grundfos designed the CRN MAGdrive to be exactly that. Its pump shaft is rotated from the outside by the forces of magnetism, so the liquid cannot escape its closed circuit. Everything stays put – which is good news for your processes, your working environment, and the environment in general.

Rated power up to 22 kW

The advantages of the hermetically sealed magnetic drive are available on CRN pumps with a rated power up to 22 kW. No matter how powerful a motor you need, you get a pump which combines high speed and compactness – and the benefits of patented technologies you won't find anywhere else. Naturally, the MAGdrive series has the superior reliability and performance you expect from a CR solution.



How it works

A magnetic coupling uses the force of magnetism to transmit power from the drive to the shaft. As the illustration shows, the magnets are located inside completely separate parts – only the force of magnetism connects the two. When the drive moves the magnets marked “A”, it makes the magnets marked “B” turn as well, causing the shaft in the liquid to rotate and create the required pumping action. In contrast to traditional pumps, the shaft does not penetrate through the two parts. This means that there are no holes or seals through which the liquid can escape. The result is hermetically sealed, safe pumping.

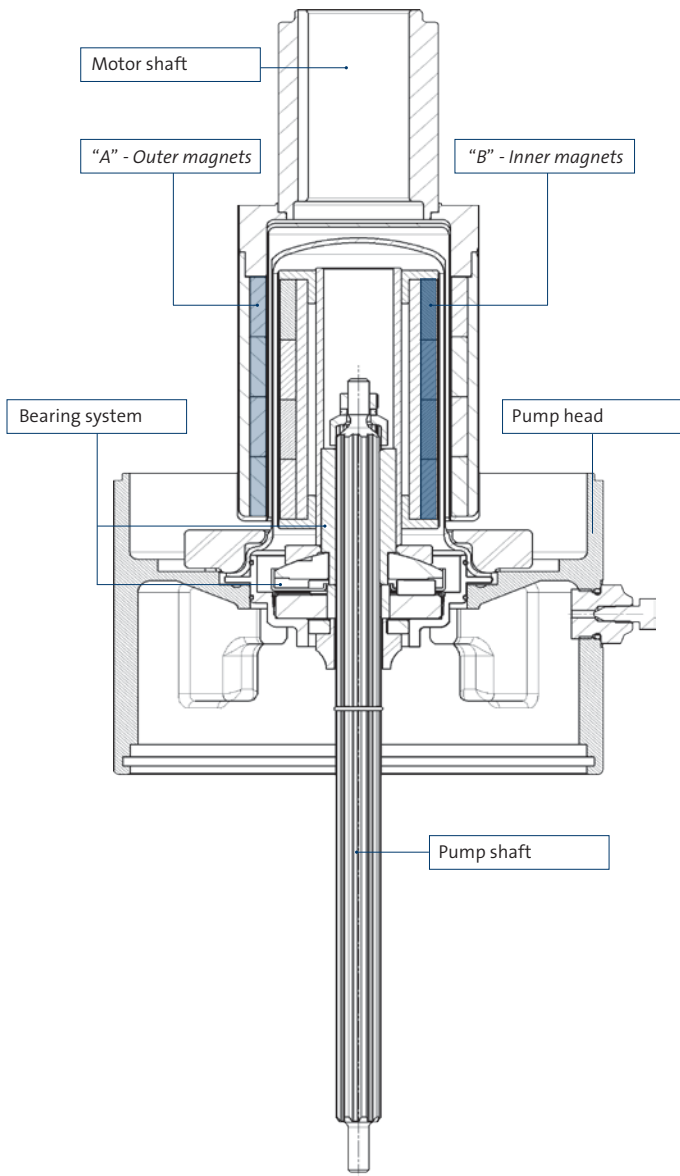

Customise as you please

A magnetic coupling is one way to customise your CR pump for demanding industrial applications. There are many more. The CR range is famed for giving you the greatest possible choice: take your pick from a wide range of motor types, materials, couplings, surface treatments, and much more. There are over one million possible combinations. So there's sure to be one to suit you. For details, visit www.grundfos.com/cr

Technical data	
Max. pressure	25 bar
Max. ambient temp.	40°C
Max. liquid temp.	120°C
Flow range	Up to 120 m ³ /h
Viscosity range	0.3 - 300 mPas

Worldwide pump supplier

Being a worldwide pump supplier, Grundfos has committed itself to provide its clients with a global, reliable and efficient service network. Our experienced team of service technicians are always ready to serve you wherever in the world you are and – of course – at a short notice – whenever you need it.

AUSTRALIAN DISTRIBUTOR



CALL 1300 789 466
When Pump Knowledge Matters
www.kelairpumps.com.au

www.grundfos.com

