

WELCOME THE  
5<sup>TH</sup> GENERATION



# HYDROVAR

HYDROVAR FROM XYLEM HAS BECOME THE NAME OF CHOICE FOR CONTROLLING THE EFFICIENCY OF FIXED SPEED PUMPS.

# In 1993 HYDROVAR was as the world's first pump Now the 5<sup>th</sup> generation h setting a new standard.

HYDROVAR 1<sup>st</sup>  
generation



HYDROVAR 5<sup>th</sup>  
generation

# established controller. as arrived and is

Typical applications.



# What is HYDROVAR capable of?

HYDROVAR is an intelligent controller that matches pump performance to demand. It controls the speed of a standard IEC motor by converting the fixed voltage and frequency from the power supply line.

It can be fitted easily to any new pump system or retrofitted to existing pumps using the fast and easy "clip and play" mounting clamps.

Pump systems are very often oversized for the application and therefore using much more energy than needed.

With energy savings of up to 70% at partial loads alone, the typical investment payback period is less than 2 years, depending on energy costs and pump operating times.

A motor running at 80% of its maximum speed uses 48% less energy and slashes carbon emissions.

The controls available include constant pressure, system curve, constant flow or via an external signal. In addition to these functions HYDROVAR can do things that are normally only performed by the most advanced computerized control systems such as: stopping the pump or pumps at zero demand; stopping the pump or pumps in case of water failure; allowing protection against dry running; a standard feature of a 2nd required input value that allows change over between two different pressure settings via an external switch; sensor failure and over temperature of inverter and motor which protects the pump and motor from under or overvoltage.

Other features include: automatic test starts; auto cyclic change of lead and lag pump units; a memory for any inverter fault signals; an operating hours run counter; two levels of password protection if required.

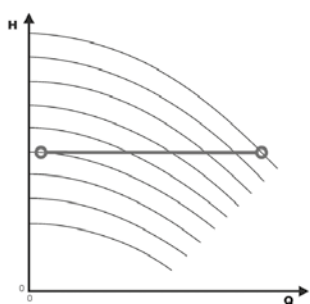

Control for constant pressure

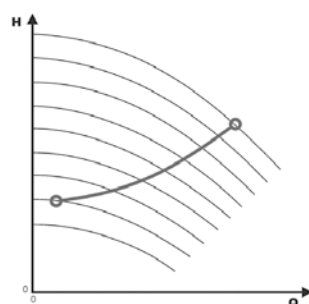

Control to match a system curve

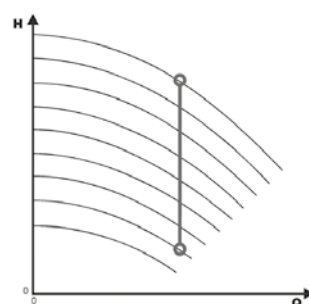

Control for constant flow

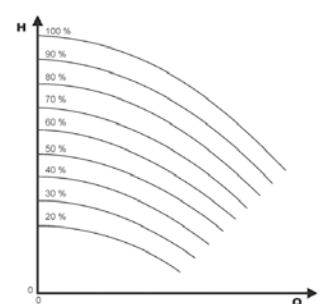

Control according to an external signal

# HYDROVAR product overview.

Available from 1.5 to 22 kW in single or three phase, pump or wall mounted.

---

Pump mounted version will fit on any standard IEC motor. Optimised cooling of the HYDROVAR depending on the power and the speed of the pump is guaranteed by the motor fan.

---

Easy to commission, easy to setup and operate with the easy start up menu allowing you to walk through every step. New features include a larger screen display.

---

No external control panel needed.

---

No water hammer. The steady operation of the pump in partial loads also prevents water hammer, which normally arises in the start/stop operation of full speed pumps.

---

Lower starting current. High current peaks are prevented by adjusting the start ramp times as you can in a soft starter.

---

Multi-pump capability comes as standard which allows control from 1 to 8 pumps. Communicating with a central control system is also possible via an RS485 interface, and each HYDROVAR contains an individual microprocessor which operates independently if a failure occurs. Modbus and BACnet protocol fitted as standard.

---

Lower noise from the pump because of lower speeds during operation. There is less noise in the pipeline and valves because of pump performance to the actual demand, and control along the system curve.

---

Less wear and less mechanical stress because of lower speed of the pumps during operation and no additional load in the starting moment because of the soft start feature.

---

Can link up to 8 pumps using HYDROVAR.

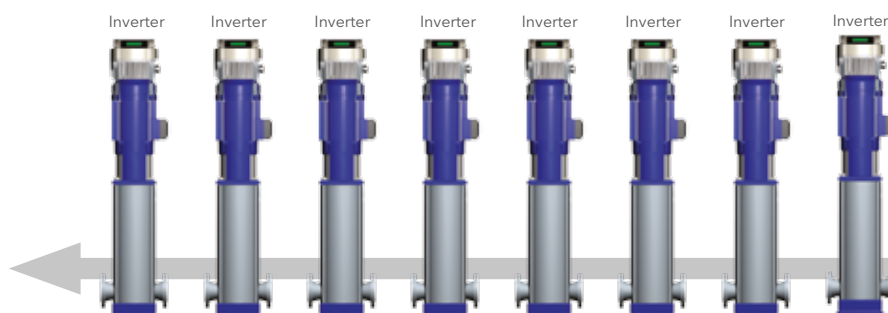

Multi controller, cascade relay:  
This is where you can fit one HYDROVAR and up to five slave fixed speed pumps which are switched to on/off on demand. Using this type of system requires a premium card and an external control panel.

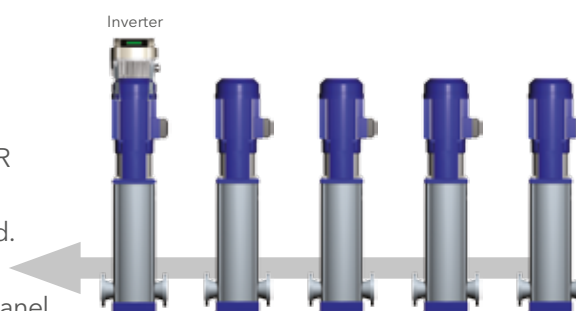

# The 5<sup>th</sup> generation takes of robustness, safety, sec

## Easy and safe accessibility for the wiring harness

- Separate wiring chamber with a dedicated cover
- All internal electronic components are protected



## Range extension

- The new models are:
  - 1.5kW 3ph 380-460V
  - 1.5kW to 11kW 3ph 208- 240V
  - 3 kW and 4 kW 1ph 208-240V



## Additional features of HYDROVAR:

- HYDROVAR can be fitted on any standard IEC motor up to 22 kW. Wall mounting kits are available on request
- No separate microprocessor is needed
- No separate control panels are needed
- No large pressure vessels are needed
- No anti-con heaters are needed as these are built in as standard
- IP55
- Error logs and real time and date calendar
- Quality aluminum body

## Advanced motor control

- Reduced heating of the motor
- Extended lifetime of the motor
- Due to built-in selectable software protection, motor PTC can be optional
- Minimised drive losses

# HYDROVAR to a new level of security and performance.

## THDi filter embedded

- Will extend the lifetime of equipment
- No need for line reactor filters
- Better quality of the grid power
- Reduced heating of the cables

## Extended communication capabilities

- BACnet and Modbus as standard
- Wi-Fi card as an option

## Control offering

- Multi-pump capability come as standard from 1-8 pumps
- Constant pressure
- Constant flow
- System curve
- Via an 4-20ma or 0-10V external signal
- Automatic test and auto change over
- It stops at zero demand
- Integrated soft start/stop
- Complete set of analog and digital input/output
- The premium card also allows an additional 2 x inputs and 2 x outputs

## Easier to commission and to operate

- Quick start-up menu allowing faster set-up
- Larger LCD display with additional control parameters
- 28 languages within the software
- Pre-programmed parameter for standard motors

## HYDROVAR built in protection

- Over/under voltage
- Overcurrent/output short protection
- Low water protection (by using pressure/flow/float switch)
- Sensor failure
- Motor over temperature
- Inverter over temperature
- Minimum threshold/conveyer limit

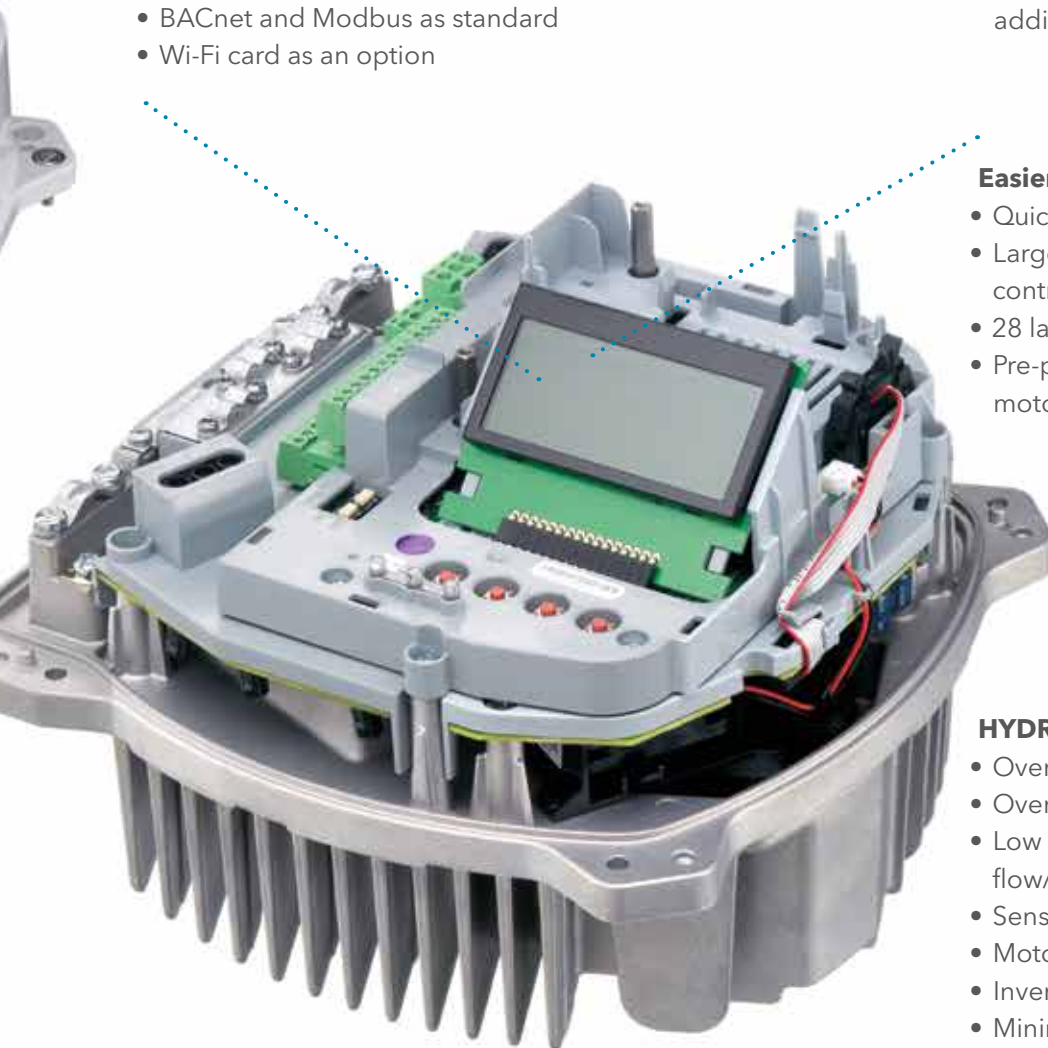

# Ecodesign directive.



## EN 50598

The Ecodesign directive has been in place since 2011 and introduced minimum requirements for the efficiency of AC motors. These requirements have been gradually intensified. The EN 50598 standard defines efficiency classes for motor systems.

## EN 50598-1

Integration of the frequency converter and motor into an "extended product" IE - a pump.

## EN 50598-2

Similar to the IE classification of motors (where all Lowara motors are IE3), EN50598-2 introduces IE classes for frequency converters and IES classes for frequency converters plus motor systems (known as power drive systems). This new regulation was published in early 2015.

Classes IE0 - IE2 for frequency converters.

Classes IES0 - IES2 for power drive systems (frequency converter plus motor).

The EN 50598-2 standard defines efficiency classes from IE0 - IE2 for frequency converters. If a frequency converter has 25% greater losses than the reference value of IE1 then it is classified as IE0; if it has 25% lower losses than the reference value of IE1 then it is classified as IE2.

This new standard covers frequency converters that meet the following criteria:

- Power rating from 0.12 kW to 1000kW.
- Voltage range from 100V to 1000V.

## Legal requirements

In Europe the minimum efficiency performance standards (MEPS) are expected to be at IE1 level in 2018.

HYDROVAR is classified as IE2 which is the most efficient in class; this efficiency measure includes the losses due to the built in RFI filters and DC chokes which come as standard up to 22kW in size.

When HYDROVAR is connected to a Lowara IE3 motor then the system will achieve the highest IES class - IES2.

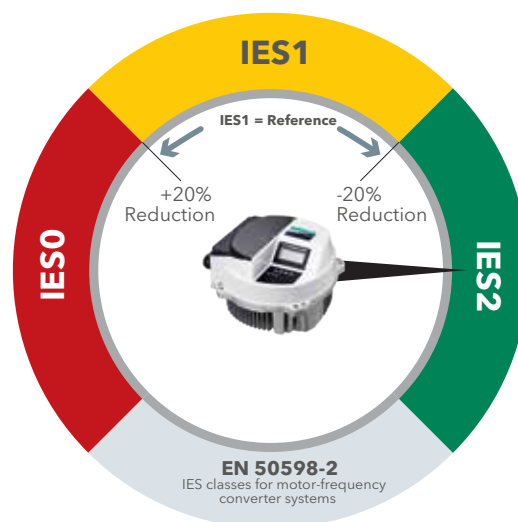
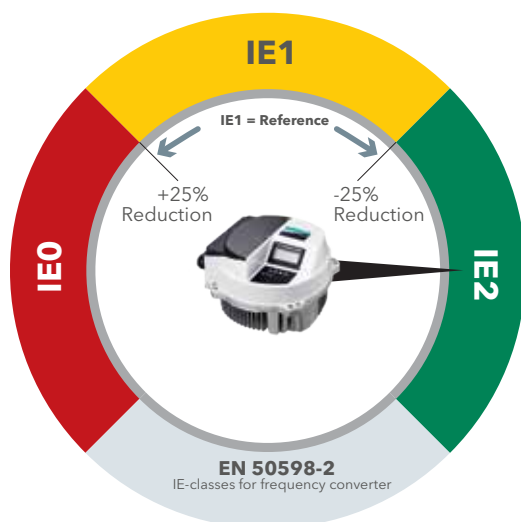

# HYDROVAR harmonics and EMC.

Hydrovar fulfills the product standard EN61000-3-2 for single phase and EN61000-3-12 for three phase.

## **Harmonics.**

HYDROVAR comes with built in Total Harmonic Distortion current filters (THDi) to reduce harmonic interference. In most cases this is sufficient to avoid voltage pollution. Additional harmonic suppression may be required due to grid conditions or when multiple drives are installed.

Harmonics are associated with any load that uses a rectifier-based power supply such as radio or TV, computers and lighting ballasts - and other domestic white goods such as washing machines, microwaves and ovens which draw current in a non-sinusoidal fashion.

The level of harmonics reflected back to the supply network is usually regulated by the electricity supply utility. Harmonics are voltages and currents in the electrical system at frequencies that are multiples of the fundamental frequency.

Generally the greater the amount of installed electronic power switching equipment on site, the greater degree of harmonic distortion. Put simply, harmonics reduce reliability, affect product quality and increase operating costs.

## **EMC.**

HYDROVAR fulfills the product standard EN61800-3:2004 + A1: 2012 under the 1<sup>st</sup> Environment which includes domestic premises and buildings/facilities which are directly connected to a low voltage (e.g. 230/400V) mains supply which also supplies buildings used for domestic purposes.

## **HYDROVAR Vector Control (HVC).**

The HVC automatically and continuously adjusts the output frequency and voltage to optimize the motor operation over a broad range of speeds and loads. For variable torque pump applications, there is no need to de-rate the motor for any operational speed.

**HVC is superior to the traditional PWM control schemes in the following ways:**

Full rated motor voltage is provided at rated frequency.

The output current wave shape is an almost a perfect sine wave.

**Automatically chooses motor control for the operating conditions:**

The low speed switching pattern ensures reliable starts and smooth low speed operation.

The high speed switching pattern minimizes switching losses and maximizes drive efficiency. The HVC maximizes the performance and the efficiency of the system while minimized the heating of the motor which results in a longer life.

### Automatic Motor Parameter Identification (AMPI).

AMPI is an algorithm to measure the electrical motor parameters on a motor at rest. This means that AMPI itself does not supply any torque. AMPI is useful when commissioning systems and optimising the adjustment of the frequency converter to the applied motor. Lowara 2 pole high efficiency IE3 50Hz surface motors have parameters already preset as default. This feature is particularly used where the default setting does not apply to the connected motor. The benefit of this feature is to maximize the control and efficiency of the HYDROVAR for any given standard asynchronous motor.

### Motor thermal protection.

HYDROVAR has built in software thermal control (STC) so no need for fitting motor PTCs. The STC function is initialized at 1.125 x rated motor current and rated motor frequency. The STC function provides class 20 motor overload protection in accordance with the NEC. Motor thermal protection prevents the motor from overheating. The STC function is an electronic feature that simulates a bimetal relay that is based on internal measurements. The characteristic is shown in the following figure.

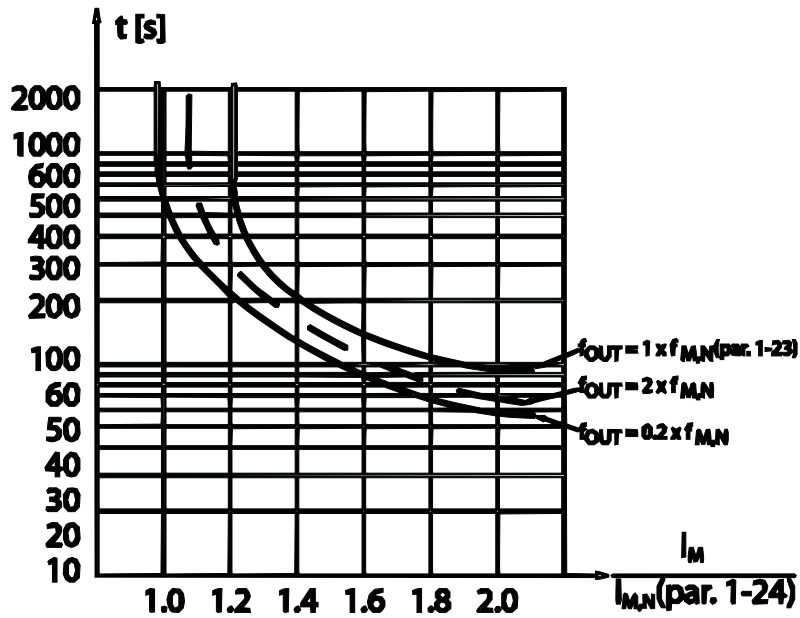

# Optional components.

Premium card	Card which will allow up to 5 slave pumps and additional analog and 2 x inputs and 2 x outputs
Wi-Fi card	To connect HYDROVAR via wireless connection
Sensors	Different sensors are available from pressure, differential, temperature, flow indicator or level sensor
Wall mounting kit	Stainless steel wall mounting kit fitted with external cooling fan and connection box
Fan cowl mounting ring	Used for plastic fan cowls, 140mm or 155mm in diameter
Motor filters	-
Motor cables	Cable that is ready to connect to the unit and motor

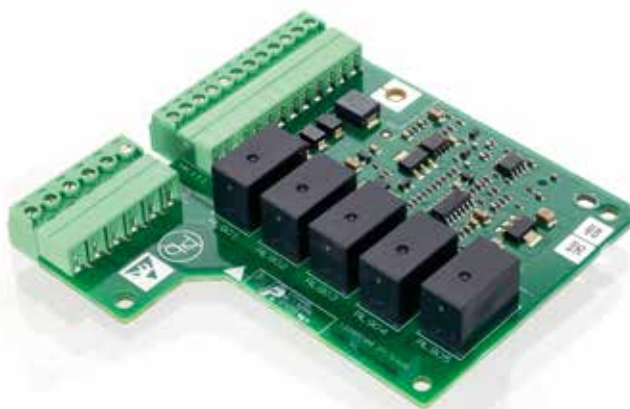

# Benefits.

Single-speed drives start motors abruptly, subjecting the motor to high torque and current surges up to 10 times the full-load current. In contrast, variable-frequency drives offer a "soft start" capability, gradually ramping up a motor to operating speed. This lessens mechanical and electrical stress on the motor system and can reduce maintenance and repair costs and extend motor life.

## Other advantages of frequency controllers

Lower starting current

Reduced mechanical stress

Flexibility of operation

Reduced noise levels

Payback costs in energy and payback

Reduced hardware requirements - starters, power factor correction, metering/monitoring, PI control, etc. no longer required

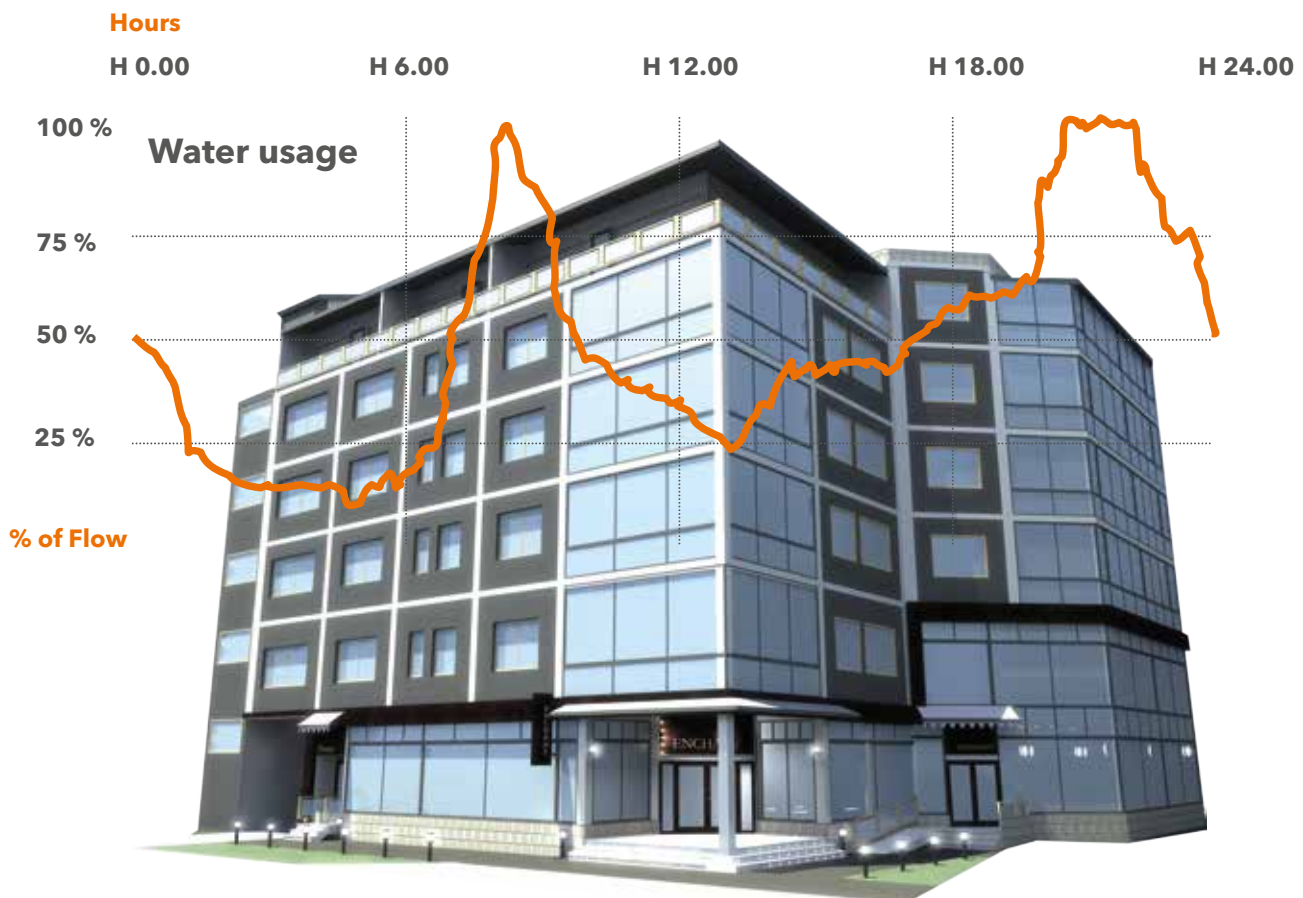

*Water consumption in a hotel is not uniform during the day. The pumping system should be able to match the real needs of the users.*

# Life Cycle Cost (LCC) calculation.

It's also important to look at Life Cycle Costs (LCC).

Pumping systems account for nearly 20% of the world's electrical energy usage. Some studies show that between 30 and 50% of energy consumed by a pump could be saved through the use of fitting a VSD. The main economic reasons for using LCC is because companies are becoming increasingly aware of the environmental impacts and looking at energy efficiency as one way of reducing emissions and preserving natural resources.

Existing pumping systems provide a greater opportunity for saving money not just by fitting VSDs but looking at installing new pumps which have higher hydraulic efficiencies and also motors which have changed over the years to become more efficient. This is due to the strict EU regulations which have been adopted over the past and coming years to save energy usage.

As a general guide these figures are realistic, but the percentages could change from job to job, depending on the size / type / and complexity of the installation. The idea here is to give the consultant the perspective that if you save on the energy cost - this makes up a huge part of the LCC, and therefore saving energy will save money.

Calculation of LCC = Life Cycle Costs

$$LCC = C_{ic} + C_{in} + C_e + C_o + C_m + C_s + C_d + C_{env}$$

$C_{ic}$  Initial costs, purchase price (pump, pipe, valves, auxiliary)

$C_{in}$  Installation and commissioning

$C_e$  Energy costs

$C_o$  Operating costs

$C_m$  Maintenance costs

$C_s$  Downtime, loss of production

$C_d$  Decommissioning

$C_{env}$  Environmental

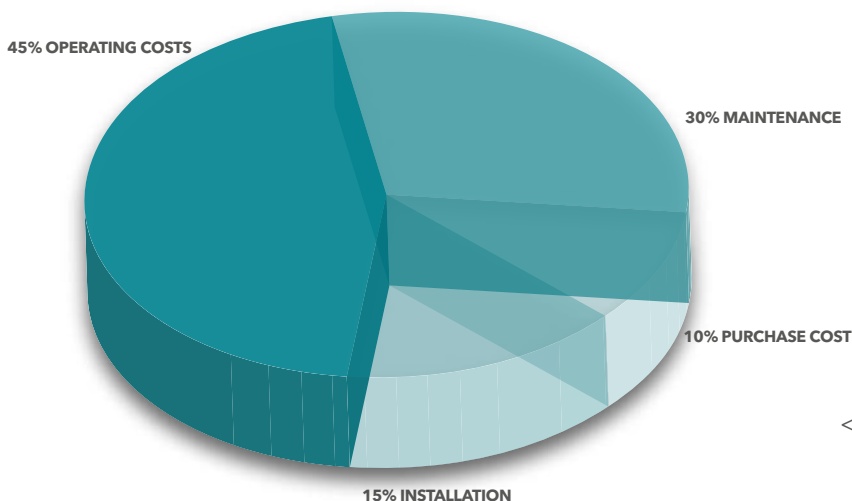

<< This picture shows the typical LCC of a 15 year life cycle of a pump.

# Energy efficiency funding schemes.

The graph below is an indication of the benefits of fitting HYDROVAR to each fixed speed motor.

Please check with your local country government efficiency project schemes; grants may be available towards installing inverter technology on electric motors to achieve substantial energy savings by reducing motor speeds.

## HYDROVAR cost savings examples

Size of motor for pump unit	3 kW	3 kW	5.5 kW	5.5 kW	11 kW	11 kW	22 kW	22 kW
Cost of energy (€)	0.22	0.22	0.22	0.22	0.22	0.22	0.22	0.22
Flow in % of full rated flow	60	80	60	80	60	80	60	80
Weeks per year	48	48	48	48	48	48	48	48
Days per week running	5	5	5	5	5	5	5	5
Hours per day running	12	12	12	12	12	12	12	12
Cost of single HYDROVAR (€)	1,400	1,400	1,700	1,700	2,500	2,500	2,800	2,800
Cost of installation (€)	300	300	300	300	300	300	300	300
Interest rate (%)	3	3	3	3	3	3	3	3
Power used	0.65 kW	1.54 kW	1.19 kW	2.82 kW	2.38 kW	5.63 kW	4.75 kW	11.26 kW
Power saved	1.53 kW	1.24 kW	2.80 kW	2.28 kW	5.61 kW	5.56 kW	11.21 kW	9.13kW
Money saved in euros per year	968.65 euro's	788.45 euro's	1,775.85 euro's	1,445.50 euro's	3,551.71 euro's	2,890.99 euro's	7,103.42 euro's	5,781.98 euro's
Energy saved	4,402.94 kWh	3,583.87 kWh	8,072.06 kWh	6,570.43 kWh	16,144.13 kWh	13,140.86 kWh	32,288.26 kWh	26,281.73 kWh
<b>Payback</b>	<b>1.83 years</b>	<b>2.26 years</b>	<b>1.28 years</b>	<b>1.58 years</b>	<b>0.81 years</b>	<b>1 years</b>	<b>0.45 years</b>	<b>0.55 years</b>

Notes: we have based some assumptions on the examples of fitting HYDROVAR onto fixed speed motors:

1. The cost of energy, we have assumed 0.22 euros per kW.
2. We have used two % of the full flow rate being 60% and 80%.
3. We have used 48 weeks per year, 5 days per week, 12 hours per day.
4. We have based an average cost of the HYDROVAR.
5. We have assumed an average installation fitting cost.

With all this information we can use an estimated payback for fitting a HYDROVAR VSD in terms of time, money and power saved.

# Start-up menu.

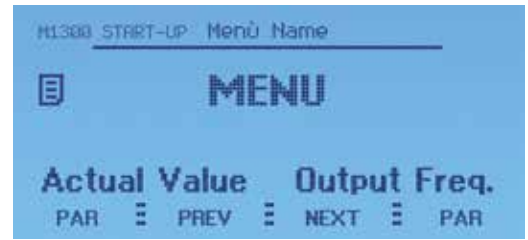

HYDROVAR start-up screen

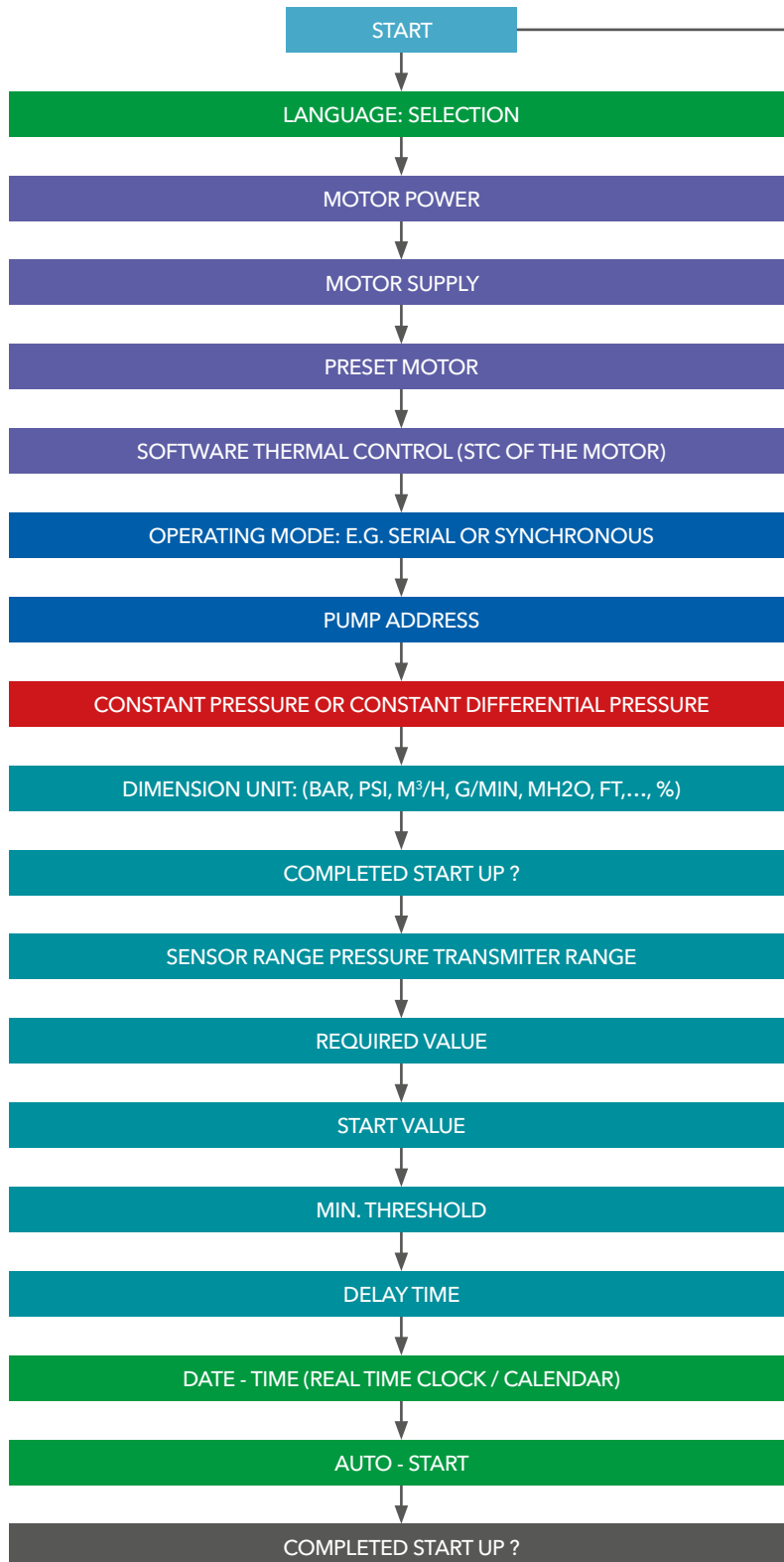

AFTER 10 MINUTES IF THE START UP IS NOT COMPLETED THE HV WILL DISPLAY A WARNING SHOWING THE CUSTOMER TO COMPLETE IT.

COMMENT: BY DEFAULT SOME PARAMETERS WILL CHANGE (RAMPS, SENSORS, HYSTERESIS ETC...)

# Energy savings in HVAC systems.

Energy is the largest cost of running any pump, with the biggest potential savings. HYDROVAR works with your system to make it efficient. This intelligent variable speed drive controls the pump exactly according to the current requirements of the user. Compared to an unregulated system, HYDROVAR saves up to 70% of the energy consumption (as tested by TÜV Austria, vogw0312-PIR-ZR). The smooth regulation at optimal operation increases not only the efficiency but also the life of the system's components and reduces maintenance costs.



# Dimension and weight.

## Model A

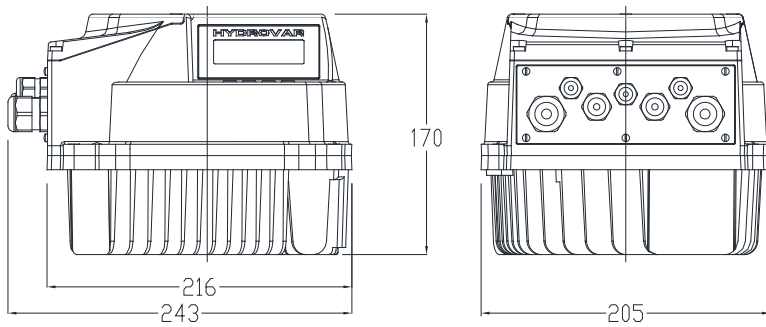

Model Type	Model Size	Maximum Weight
2.015	A	5,6 kg (12.31 lbs)
2.022	A	5,6 kg (12.31 lbs)
3.015	A	5,6 kg (12.31 lbs)
3.022	A	5,6 kg (12.31 lbs)
4.015	A	5,6 kg (12.31 lbs)
4.022	A	5,6 kg (12.31 lbs)
4.030	A	5,6 kg (12.31 lbs)
4.040	A	5,6 kg (12.31 lbs)

## Model B

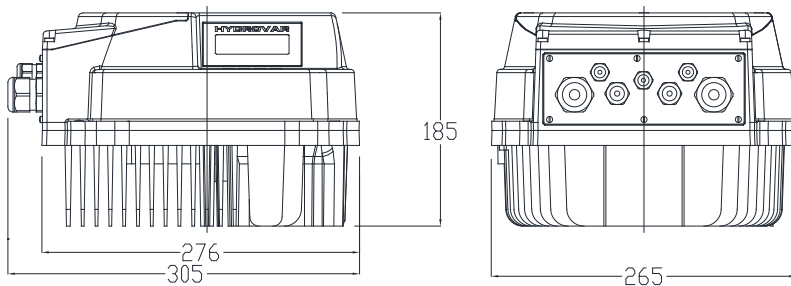

Model Type	Model Size	Maximum Weight
2.030	B	10,5 kg (23.14 lbs)
2.040	B	10,5 kg (23.14 lbs)
3.030	B	10,5 kg (23.14 lbs)
3.040	B	10,5 kg (23.14 lbs)
3.055	B	10,5 kg (23.14 lbs)
4.055	B	10,5 kg (23.14 lbs)
4.075	B	10,5 kg (23.14 lbs)
4.110	B	10,5 kg (23.14 lbs)

## Model C

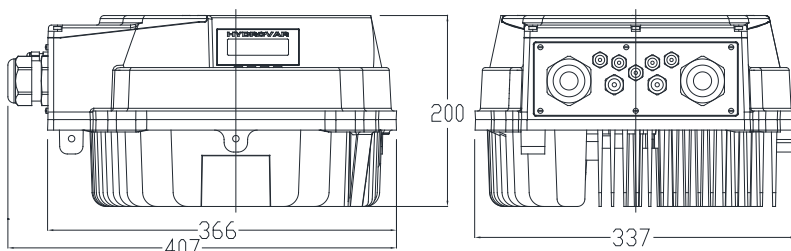

Model Type	Model Size	Maximum Weight
3.075	C	15,6 kg (34.39 lbs)
3.110	C	15,6 kg (34.39 lbs)
4.150	C	15,6 kg (34.39 lbs)
4.185	C	15,6 kg (34.39 lbs)
4.220	C	15,6 kg (34.39 lbs)

# Electrical Data.

Model Type	Rated output	Nominal input voltage	Model Size	Max Input current (A)	Efficiency Rated (%) typical	Output voltage (V)	Max output current (A)	Output frequency (Hz)
2.015	1.5 kW	208-240±10% (Single phase)	A	11.6 A	94%	0-240 (Three phase)	7.5 A	15-70 (Hz)
2.022	2.2 kW	208-240±10% (Single phase)	A	15.1 A	93.5%	0-240 (Three phase)	10 A	15-70 (Hz)
2.030	3 kW	208-240±10% (Single phase)	B	22.3 A	93.5%	0-240 (Three phase)	14.3 A	15-70 (Hz)
2.040	4 kW	208-240±10% (Single phase)	B	27.6 A	93.5%	0-240 (Three phase)	16.7 A	15-70 (Hz)
3.015	1.5 kW	208-240±10% (Three phase)	A	7 A	96%	0-100% of supply voltage	7.5 A	15-70 (Hz)
3.022	2.2 kW	208-240±10% (Three phase)	A	9.1 A	96%	0-100% of supply voltage	10 A	15-70 (Hz)
3.030	3 kW	208-240±10% (Three phase)	B	13.3 A	96%	0-100% of supply voltage	14.3 A	15-70 (Hz)
3.040	4 kW	208-240±10% (Three phase)	B	16.5 A	96%	0-100% of supply voltage	16.7 A	15-70 (Hz)
3.055	5.5 kW	208-240±10% (Three phase)	B	23.5 A	96%	0-100% of supply voltage	24.2 A	15-70 (Hz)
3.075	7.5 kW	208-240±10% (Three phase)	C	29.6 A	96%	0-100% of supply voltage	31 A	15-70 (Hz)
3.110	11 kW	208-240±10% (Three phase)	C	43.9 A	96%	0-100% of supply voltage	44 A	15-70 (Hz)
4.015	1.5 kW	380-460±15% (Three phase)	A	3.9 A	96%	0-100% of supply voltage	4.1 A	15-70 (Hz)
4.022	2.2 kW	380-460±15% (Three phase)	A	5.3 A	96.5%	0-100% of supply voltage	5.7 A	15-70 (Hz)
4.030	3 kW	380-460±15% (Three phase)	A	7.2 A	96.5%	0-100% of supply voltage	7.3 A	15-70 (Hz)
4.040	4 kW	380-460±15% (Three phase)	A	10.1 A	96.5%	0-100% of supply voltage	10 A	15-70 (Hz)
4.055	5.5 kW	380-460±15% (Three phase)	B	12.8 A	97%	0-100% of supply voltage	13.5 A	15-70 (Hz)
4.075	7.5 kW	380-460±15% (Three phase)	B	16.9 A	97%	0-100% of supply voltage	17 A	15-70 (Hz)
4.110	11 kW	380-460±15% (Three phase)	B	24.2 A	97%	0-100% of supply voltage	24 A	15-70 (Hz)
4.150	15 kW	380-460±15% (Three phase)	C	33.3 A	97%	0-100% of supply voltage	32 A	15-70 (Hz)
4.185	18.5 kW	380-460±15% (Three phase)	C	38.1 A	97%	0-100% of supply voltage	38 A	15-70 (Hz)
4.220	22 kW	380-460±15% (Three phase)	C	44.7 A	97%	0-100% of supply voltage	44 A	15-70 (Hz)

# Retrofitting.

Halve the cost of running a booster set in five steps.



Retrofitting the 'plug and play' HYDROVAR units to a fixed speed booster set not only eliminates the need for a control panel but also introduces a soft start function, that when combined with the benefits of running a pump at a variable speed, can prolong the life of the pump and the water system. By reducing the in-rush current when the pump is turned on, parts such as motor bearings and pipe fittings are protected from hydraulic shock that can cause cavitation and breakdown.

Connecting a HYDROVAR couldn't be simpler; here we demonstrate an installation in just five steps:

**Step One: Assessment of the installation site and the current pump activity.**

Before any HYDROVAR installation, the site and its current equipment should be assessed to determine the current level of energy being consumed and the kW of the motor. From here, the installer can calculate how much the booster set or heating pump is costing on an annual basis by calculating 0.22 Euros per hour for each kilowatt of energy consumed. An 11kW single pump will therefore cost €2.42 per hour to run at full speed. Once this cost has been multiplied by the number of pumps that are in use, the installer can explain in monetary terms what an average 50 per cent reduction in energy consumption would save the end user.



**Step Two: Clamping the HYDROVAR into place.**

The HYDROVAR sits directly onto the pump and utilises the cool air emitted from the fan vents to prevent overheating. This means that there is no need for an additional cooling unit, keeping the footprint of the HYDROVAR to a minimum and not utilising valuable wall space. Fixings are located on the outer casing so no need to remove

the casing of the HYDROVAR as previous models. Use the four mounting clamps provided together with the central post pin and secure it to the metal fan cowl of the pump unit. The clamps are designed to fit all IEC motors. Stainless steel ring supports are available for motors fitted with plastic fan cowls. Wall mounted versions are available as an option.

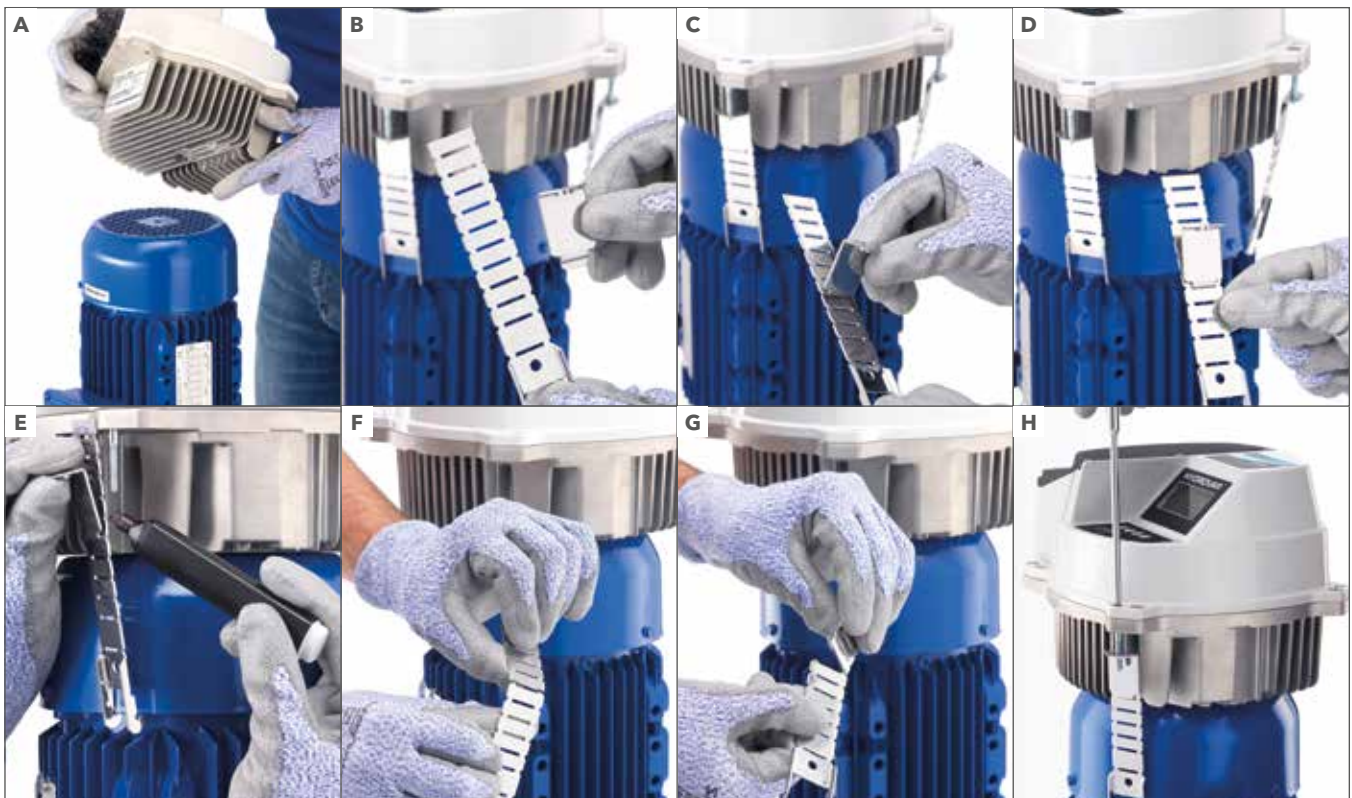

### Step Three: Pump Terminal Wiring.

After attaching the cable glands to the exposed gland plate on the left hand side of the HYDROVAR, unscrew and remove the front of the pump motor terminal box. Take the HYDROVAR connection cables (purchased separately or made using standard wires and connections) and feed the motor terminal end of the cable through the cable entry points, connecting it to the relevant terminals. If you are retrofitting the unit to an existing booster set then the power supply needs to be rerouted directly into the HYDROVAR. No PCT is required and this is now done by the internal software of the HYDROVAR. Once this is done, reattach the terminal front cover, ensuring that the water seal is correctly in place.



### Step Four: HYDROVAR wiring.

Remove the wiring chamber cover and pass the other end of the connection cable through the cable inlet on the left hand side of the HYDROVAR, connecting it to the relevant power supply and signal wires. Once this is done, connect the transducer cable (also called the sensor or pressure transmitter) to the HYDROVAR through the same gland plate. The loose end of the transducer must then be connected to the pipe as close to the pump as possible.



### Step Five: Completion and programming.

After replacing the terminal cover lid of the HYDROVAR unit, programme the required bar pressure using the buttons and the screen. Depending on the number of pumps in the booster set, some very simple programming may be required. This is detailed clearly in the operating instructions manual. The first screen after powering up the unit will be the quick start guide after setting these parameters; the HYDROVAR will automatically begin its soft start and work to the system requirements.



# Other products available in the Xylem portfolio.





# Xylem |'zīləm|

- 1) The tissue in plants that brings water upward from the roots;
- 2) a leading global water technology company.

We're a global team unified in a common purpose: creating innovative solutions to meet our world's water needs. Developing new technologies that will improve the way water is used, conserved, and re-used in the future is central to our work. We move, treat, analyze, and return water to the environment, and we help people use water efficiently, in their homes, buildings, factories and farms. In more than 150 countries, we have strong, long-standing relationships with customers who know us for our powerful combination of leading product brands and applications expertise, backed by a legacy of innovation.

For more information on Xylem go to [www.xyleminc.com](http://www.xyleminc.com)



Lowara, HYDROVAR, Xylect are trademarks or registered trademarks of Xylem Inc. or one of its subsidiaries. All other trademarks or registered trademarks are property of their respective owners.

Xylem Service Italia Srl reserves the right to make modification without prior notice.  
© 2016 Xylem, Inc.

cod. 191007781 - P10/16/KPA/0920

AUSTRALIAN DISTRIBUTOR



CALL 1300 789 466

When Pump Knowledge Matters  
[www.kelairpumps.com.au](http://www.kelairpumps.com.au)