



Goulds 3180

Paper Stock / Process Pump with
i-ALERT™ Patented Intelligent Monitoring



ITT

ENGINEERED FOR LIFE

Goulds 3180

Worldwide Experience on Process Pumping Services

When Goulds developed the 3180, we utilized 140 years of pump design experience to ensure it would have unmatched mechanical reliability. Today, installations around the world attest to its remarkable performance. The 3180 is the heavy duty process pump designed to handle all of your tough process pumping applications.

World-class Pump Line

Model 3180 is built to ANSI standards.

- ANSI class 125 / 150 lb flange drilling
- Inch-dimensioned OD of mechanical seal sleeve
- Inch-dimensioned bearing locknut
- Inch-dimensioned shaft and keyway at coupling



- Capacities to 45,000 GPM (10,220 m³/h)
- Heads to 410 feet (125 m)
- Temperatures to 446° F (230° C)
- Pressures to 232 PSIG (16 bar)



A Model 3180 installed in a North American recycle mill.



Model 3180XL on difficult high temperature service. Spring-mounted baseplate provided to compensate for thermal expansion.



Cooling water pump for primary turbine at a power plant in the Middle East.



Goulds 3180

Featuring Patented *i-ALERT*[™]
Intelligent Monitoring

PATENTED *i-ALERT*[™] CONDITION MONITOR

Constantly measures vibration and temperature at the thrust bearing. Colored LEDs indicate general pump health. Provides early warning of improper operation before catastrophic failure occurs.

STANDARD LABYRINTH OIL SEALS

Prevent premature bearing failure caused by lubricant contamination and loss of lubricant.

SEALING FLEXIBILITY

Choice of mechanical seal (illustrated), packed box or dynamic seal.

PATENTED TAPERBORE[™] PLUS SEAL CHAMBER

Wide range of sealing arrangements available to meet service conditions. Patented seal chambers improve lubrication and heat removal (cooling) of seal faces for extended seal life and pump uptime.

CASING

Top centerline discharge for air handling and self-venting. Special volute design reduces radial loads. Back pull-out design. Foot-mounted.

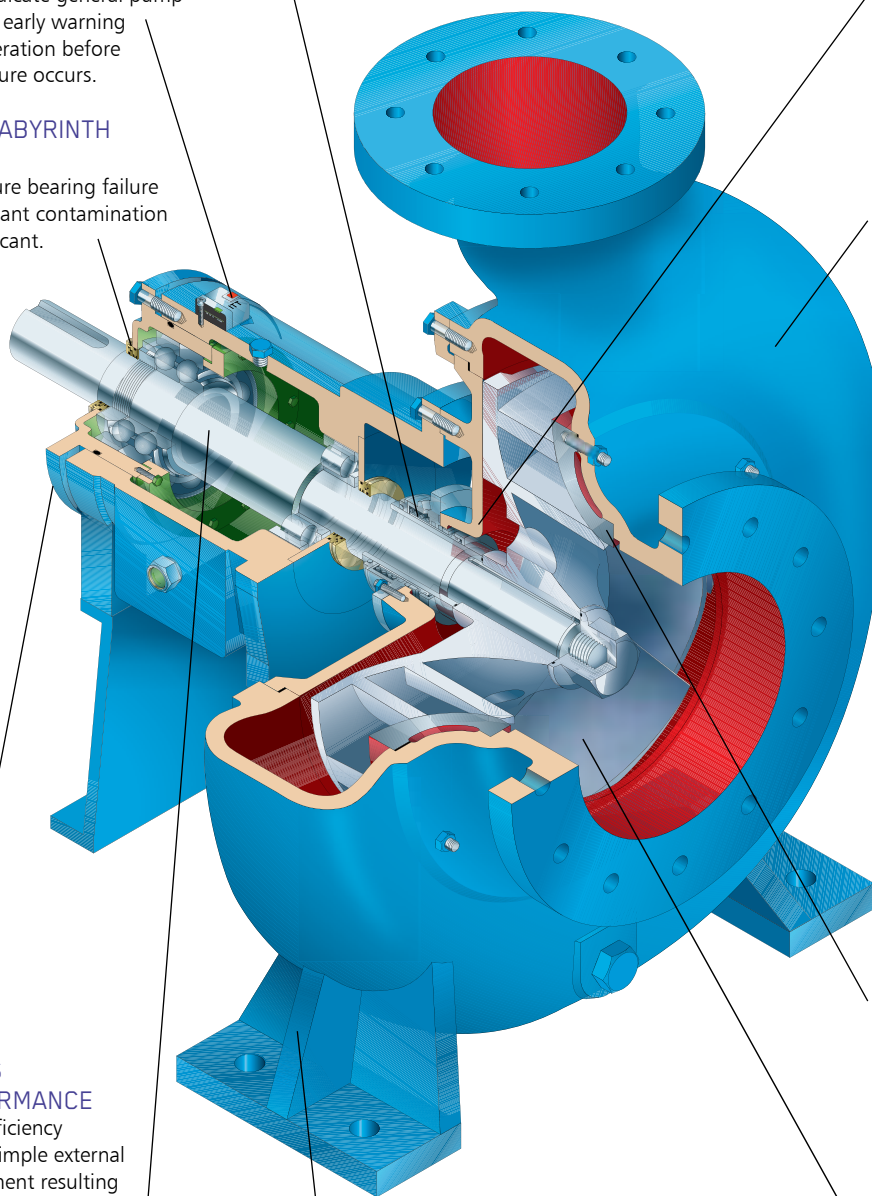

CONTINUOUS HIGH-PERFORMANCE

Original high efficiency maintained by simple external impeller adjustment resulting in long-term energy savings.

HEAVY-DUTY SHAFT

Designed for minimum deflection at maximum load. Dry shaft achieved by sealing from pumpage by O-rings at sleeve and impeller nut.

RIGID FEET

Large casing and bearing frame feet maintain driver alignment with high pipe loads; absorb system vibration.

RENEWABLE SUCTION SIDEPLATE

With open impeller design minimizes maintenance costs. Positively sealed with O-ring and gasket.

OPEN IMPELLER

Full back shroud and thick impeller vanes for handling slurries and stringy fibers. Large balance holes and back pump-out vanes minimize stuffing box pressure and axial thrust. Optional enclosed impeller available. Shearpeller[™] design available for difficult recycle services.

Engineered Impeller and Sideplate

Acknowledged Best Design for Industrial Process Services.

It offers:

- Ease of adjustment to maintain optimum performance
- Clamped sideplate for maximum reliability and zero leakage
- Minimum hydraulic loads for maximum mechanical reliability

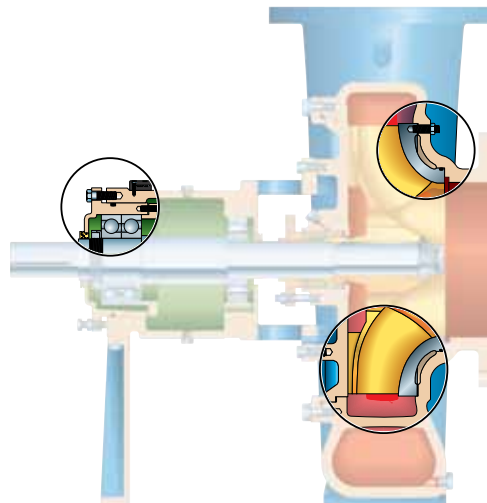

1. Renewable High-Performance

Easy and Reliable

With any impeller adjustment there will be two metal components that will have to move relative to each other. Goulds puts this precision fit in the sealed and lubricated environment of the power end.

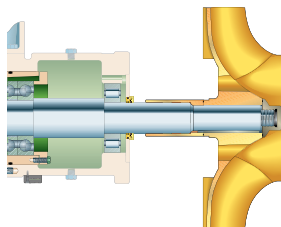

vs

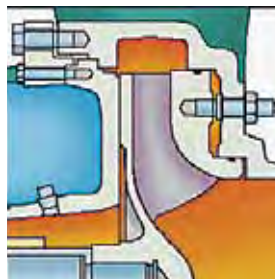

Less reliable pumps utilizing adjustable sideplates are difficult to adjust, are not precise in clearances and the adjustment must take place in the corroded casing interior leading to leakage. Improper adjustments lead to broken studs and catastrophic failure.

Easy and accessible adjustments. The Goulds adjustment bolts are very accessible and can be adjusted with one tool.



vs



The adjustable sideplate method requires two tools. Additionally, the pump suction flange limits the accessibility to the adjusting screws.

2. Clamped Sideplate

For Maximum Reliability and Zero Leakage
Our sideplate is clamped securely and sealed positively to ensure that it does not lead to breakage or leakage.

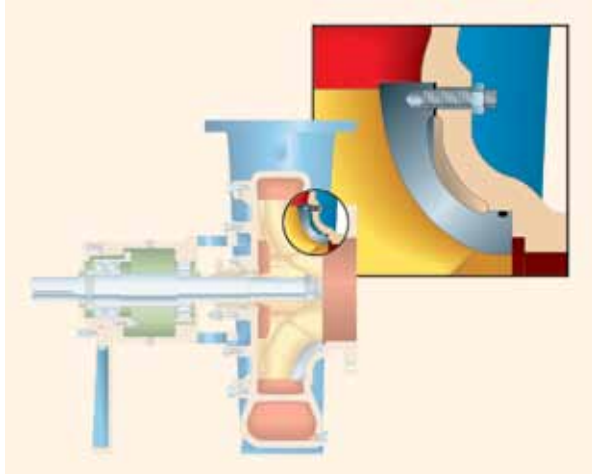

Clamped

vs

The “floating” sideplate design must scrape over a casing surface that will be corroded and fouled. This commonly leads to a leakage path through the sideplate studs.

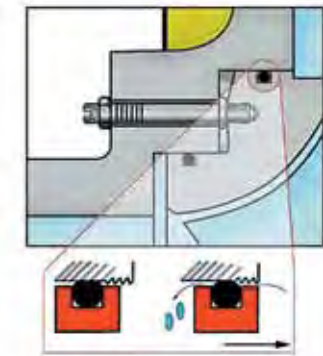

Floating

3. Minimum Hydraulic Loads

Maximum Mechanical Reliability

Goolds open impeller design was engineered to assure minimum radial and axial thrust loads to maximize seal and bearing life.

- 1 **Full Back Shroud**
Maximizes mechanical integrity
- 2 **Balance Holes**
Low axial thrust
- 3 **Engineered Back Vanes**
Extended seal and bearing life

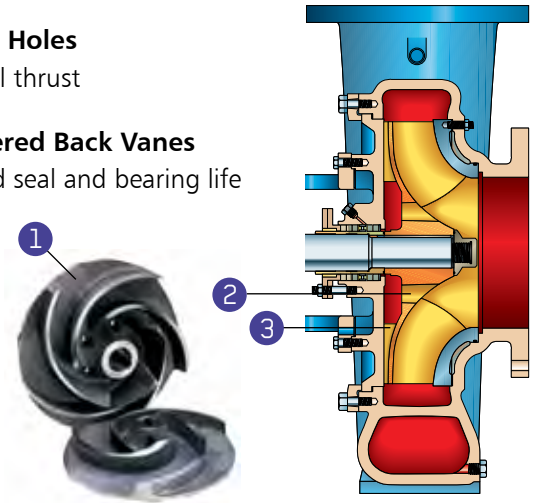

Engineered for Long Life

Back vane height / angle and shroud design are engineered to minimize hydraulic loads throughout the life of the pump. Bearing life is guaranteed.

As the open impeller is adjusted and performance renewed, back pump-out vanes control axial thrust. Bearing and seal life are maintained – unaffected by adjustment.

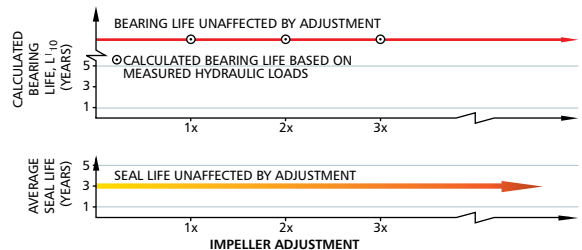
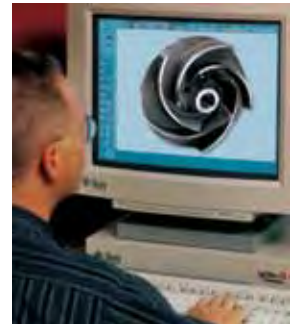

Power Ends Designed for Maximum Reliability

Power End Reliability is vital when thinking about pump mean time between failure (MTBF). To ensure maximum bearing life, the 3180 follows four key factors:

- Bearing Design Life
- Bearing Temperature
- Bearing Environment
- Continuous Condition Monitoring



1. Bearing Design Life



Bearing manufacturers state that skidding, cage stresses and oil temperatures can greatly reduce the bearing life of oversized bearings. The “right” size bearing is vital to overall bearing life.

Bearing Load Measured on Test

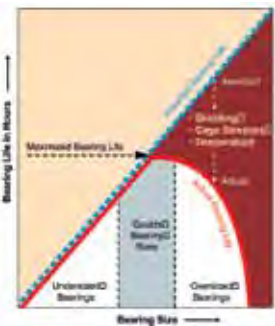

Bigger is NOT Always Better!

Bearings are often oversized because pump designers often estimate bearing loads. Goulds measured their loads on test and chose bearing designs that would enable bearing life of 100,000 hours.



2. Bearing Temperature

Keeping the pump loads minimized and selecting the “right” bearing will keep bearing temperature under control.



Typical bearing operating temperatures of competitor’s process pumps are between 140–160° F. Goulds Model 3180 bearing temperatures average only 120° F (50° C)!

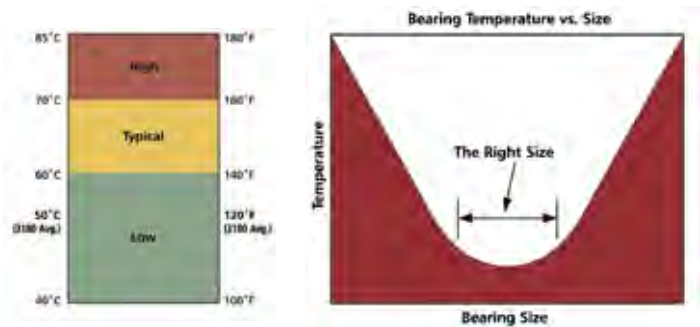

3. Bearing Environment

Labyrinth Oil Seals are Standard

Contamination being the second leading cause of bearing failure requires special attention. Common lip seals were not considered due to their 2,000 hour design life. After wearing out, there will be an open passage way for contamination.

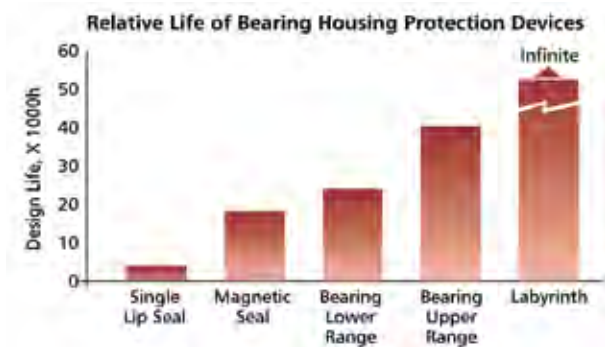

RIGID FRAME FOOT
Heavy duty foot reduces effects of pipeloads / thermal expansion on bearing life. Bearings continue to run cool.



LARGE OIL SIGHT GLASS
The standard oil sight glass assures oil level is properly set and maintained. Condition of oil is also easily monitored.

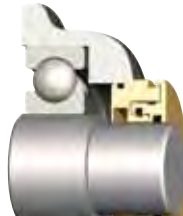

STANDARD LABYRINTH OIL SEALS
Prevent contamination of lubricant for extended bearing life.

4. Patented *i-ALERT*™ Condition Monitor

The *i-ALERT*™ condition monitor unit continuously measures vibration and temperature at the thrust bearing and automatically indicates when pre-set levels of vibration and temperature have been exceeded, so that changes to the process or machine can be made before failure occurs.

A visual indication of pump health makes walk-around inspections more efficient and accurate. The result is a more robust process to monitor and maintain all your pumps so that your plant profitability is maximized.

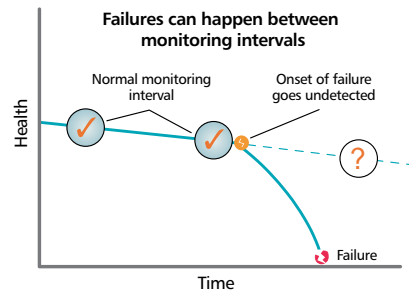

A reliability program centered around walkarounds captures equipment condition on average once a month; the failure process, however, can begin and end quite frequently within this time period.

Power End Reliability is Both Designed-In and Guaranteed

Bearing Design Life	> 100,000 hours
Bearing Temperature	120° F (50° C) average
Bearing Environment	Superior Oil Seal design
<i>i-ALERT</i>™ Guarantee	Condition Monitoring Reliability Guarantee

Our Guarantee

Goulds Pumps backs the 3180 power ends with an unconditional guarantee against defects in workmanship and material for 3 years from date of manufacture.



Goulds 3180

Impeller Designs to Optimize Performance

The right design for the service results in optimum efficiency and up-time, especially when handling difficult media such as recycle fibers with contaminants.

Open Impeller

Design suitable for most services. Allows for resistance to wear and corrosion. Provides for easily renewable clearances. Designed for optimum efficiency.



Enclosed Impeller

Available for services where efficiency is a consideration and enclosed design is suitable for service conditions. Efficiency can be renewed with axial adjustment and / or wear ring replacement. Also beneficial for high temperature services as it allows the suction sideplate to be eliminated.



Goulds Clog-Free Pumping Solution Patented Design (#6,609,890)

Pumping applications in recycle mills present unique challenges with the presence of plastic and tape along with other contaminants that can readily clog the pump impeller.



The Goulds Shearpeller™ Solves this Problem:

- Generous front clearance with vortex-type design to prevent binding and plugging.
- Patented tapered inlet sleeve prevents contaminants from plugging inlet area. The sleeve is loose to rotate independently from impeller. The slower rotation prevents contaminants from collecting at the impeller eye and prevents erosion of hub.
- Proven in tough services such as repulper dump service in OCC recycle mill. In one service, pump went from a daily outage to clear impeller to uninterrupted, continuous service.
- Component changes only involve the impeller and sleeve. Uses same casing, sideplate, shaft and impeller nut as 3180.

Optimize Seal Configuration for Service and Environment

For services with Solids and Vapor, Goulds Patented* TaperBore™ PLUS

The unique flow path created by the patented Vane Particle Ejector directs solids away from the mechanical seal, not towards the seal as with other tapered bore designs. And, the amount of solids entering the bore is minimized. Air and vapors are also efficiently removed.

On services with or without solids, air or vapors, Goulds patented TaperBore™ PLUS is the effective solution for extended seal and pump life and lower maintenance costs.

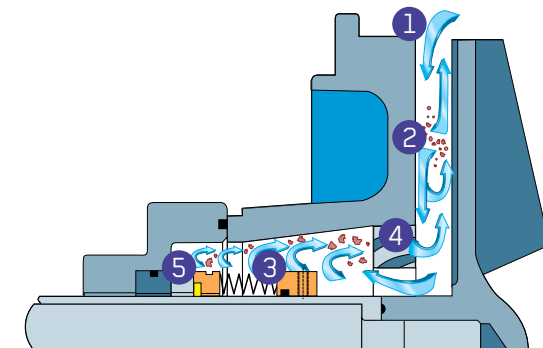

- 1 Solids / liquid mixture flows toward mechanical seal / seal chamber.
- 2 Turbulent zone. Some solids continue to flow toward shaft. Other solids are forced back out by centrifugal force (generated by back pump-out vanes).
- 3 Clear liquid continues to move toward mechanical seal faces. Solids, air, vapors flow away from seal.
- 4 Low pressure zone created by Vane Particle Ejector. Solids, air, vapor liquid mixture exit seal chamber bore.
- 5 Flow in patented TaperBore™ PLUS seal chamber assures efficient heat removal (cooling) and lubrication. Seal face heat is dissipated. Seal faces are continuously flushed with clean liquid.

Zero flush water (Mechanical seals)

The 3180 has a revolutionary seal chamber design guaranteed to operate on 6% paper stock without flush water!

Aside from the high cost of flushing mechanical seals and the possible dilution of the product, contaminants in the flush water can also cause seal failures. Disruption of flush water caused by plugging, freezing or inadvertently closing a valve can also cause failures. The answer to those problems is solved with the Goulds patented TaperBore™ PLUS.

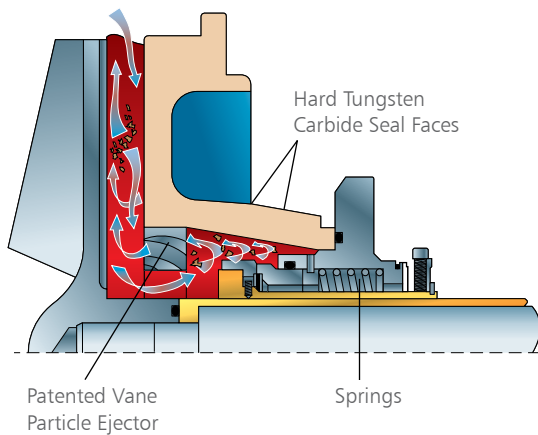

Dynamic seal

For Elimination of Mechanical Seal Problems; Reduced Maintenance

Goulds Dynamic Seal option is ideally suited to handle the tough applications where conventional mechanical seals or packing require outside flush and / or constant, costly attention. This option allows pumping slurries without an external flush. A repeller between the stuffing box cover and impeller pumps liquid from the stuffing box while the pump is running. A diaphragm seal prevents leakage when the pump is not operating.



The 3180 is easily field converted to Dynamic Seal with retrofit parts – backplate, stuffing box cover, repeller, sleeve.

Benefits of Goulds Dynamic Seal:

- External seal water not required.
- Elimination of pumpage contamination or product dilution.
- Eliminates problems and costs associated with piping from a remote source.

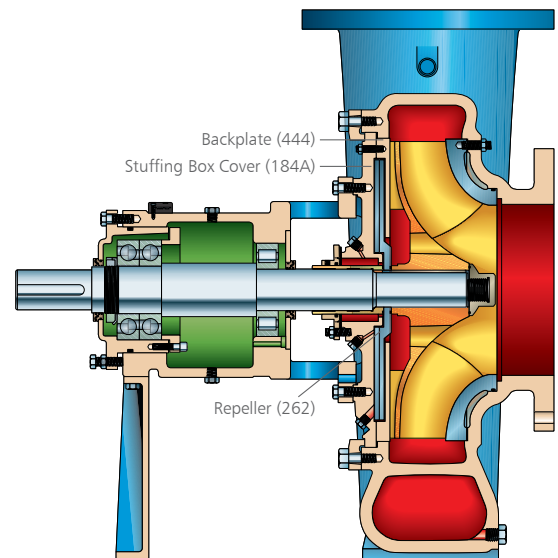

Hydraulic Coverage

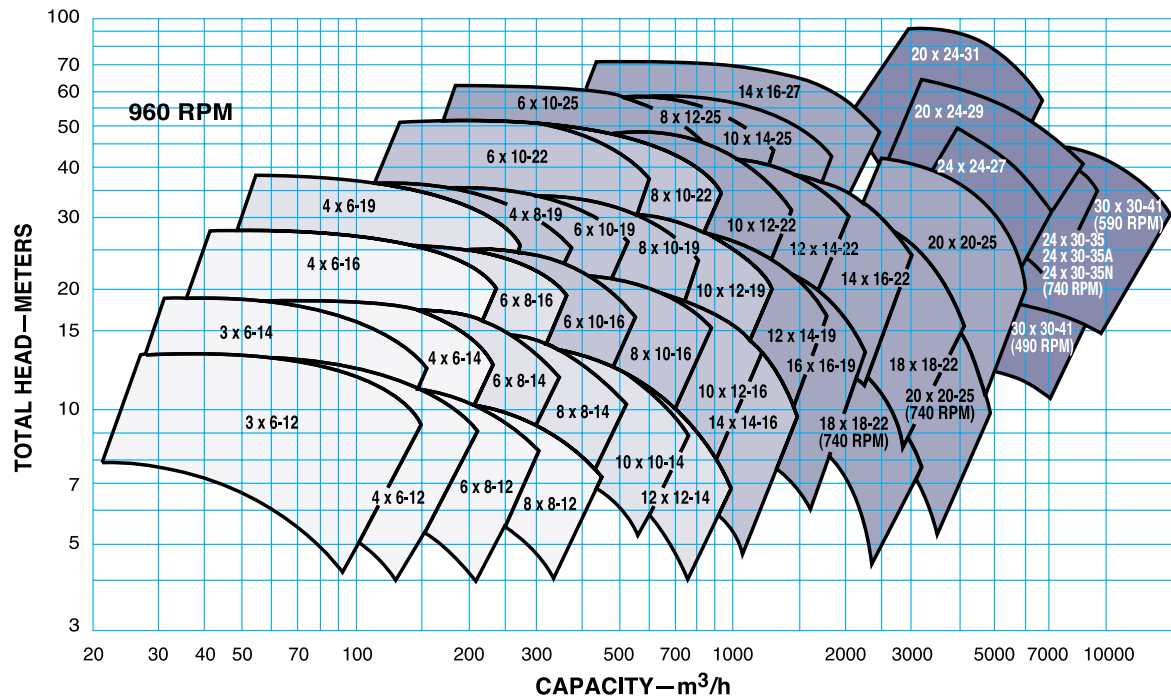
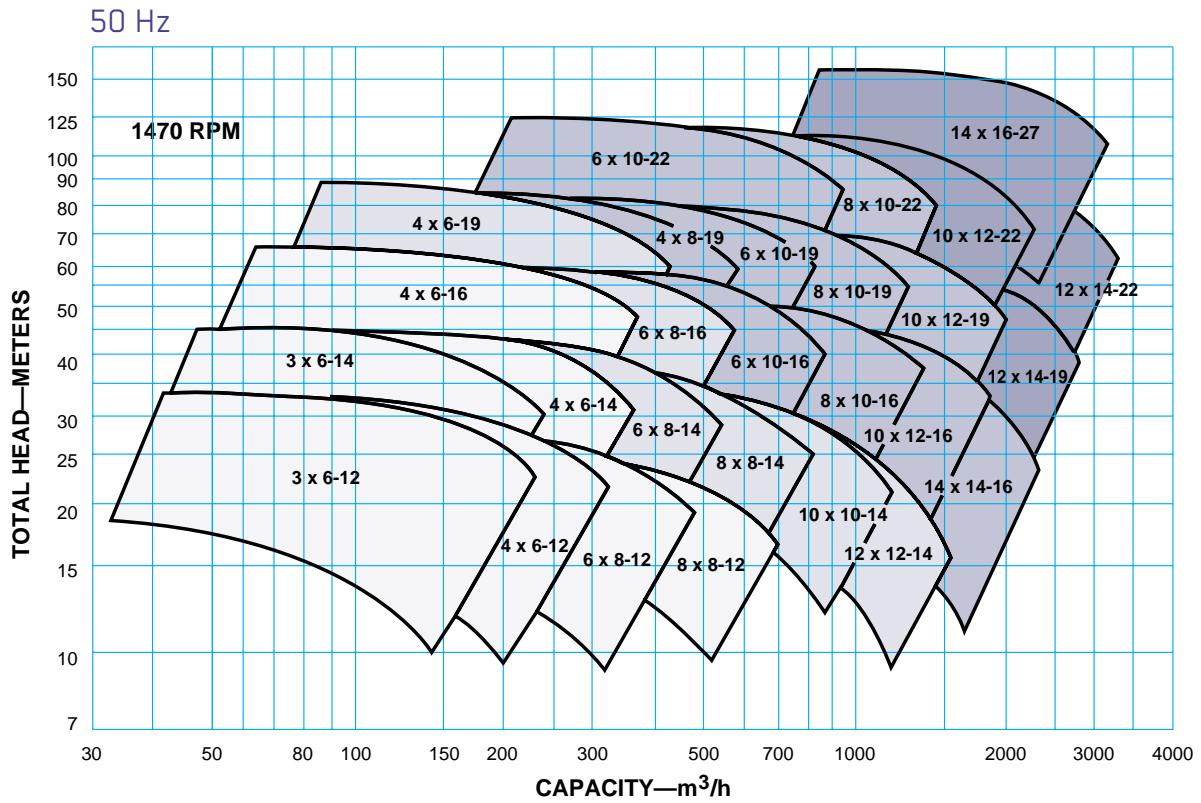

60 Hz

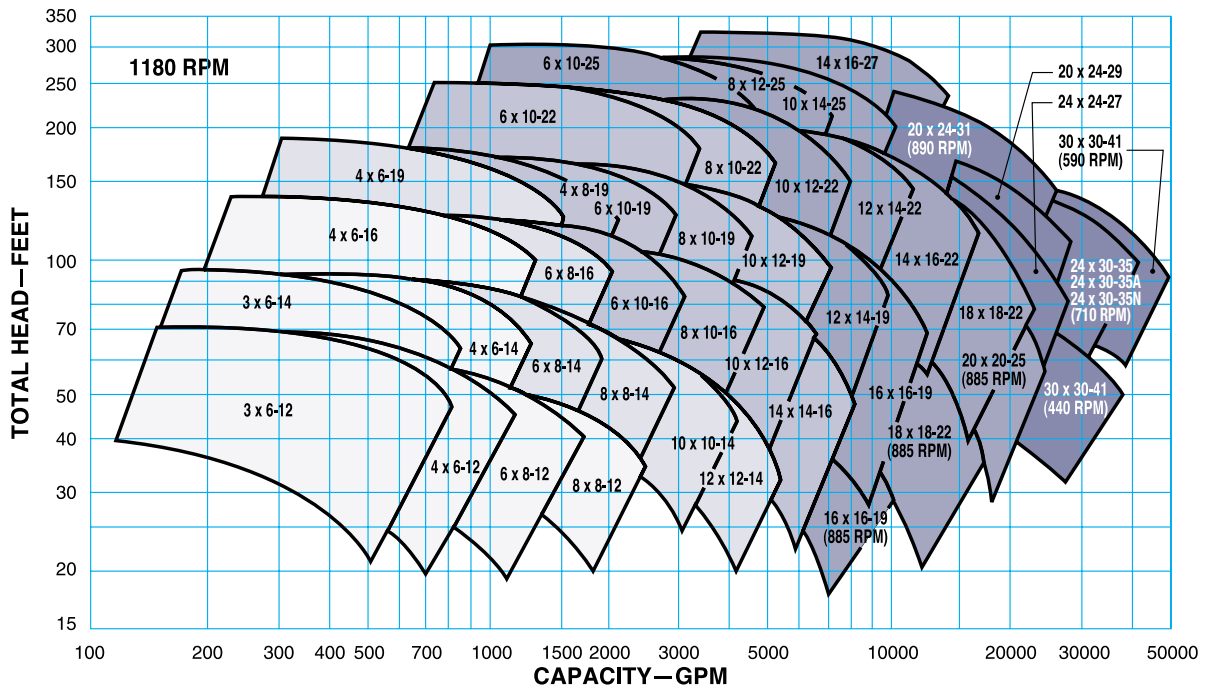
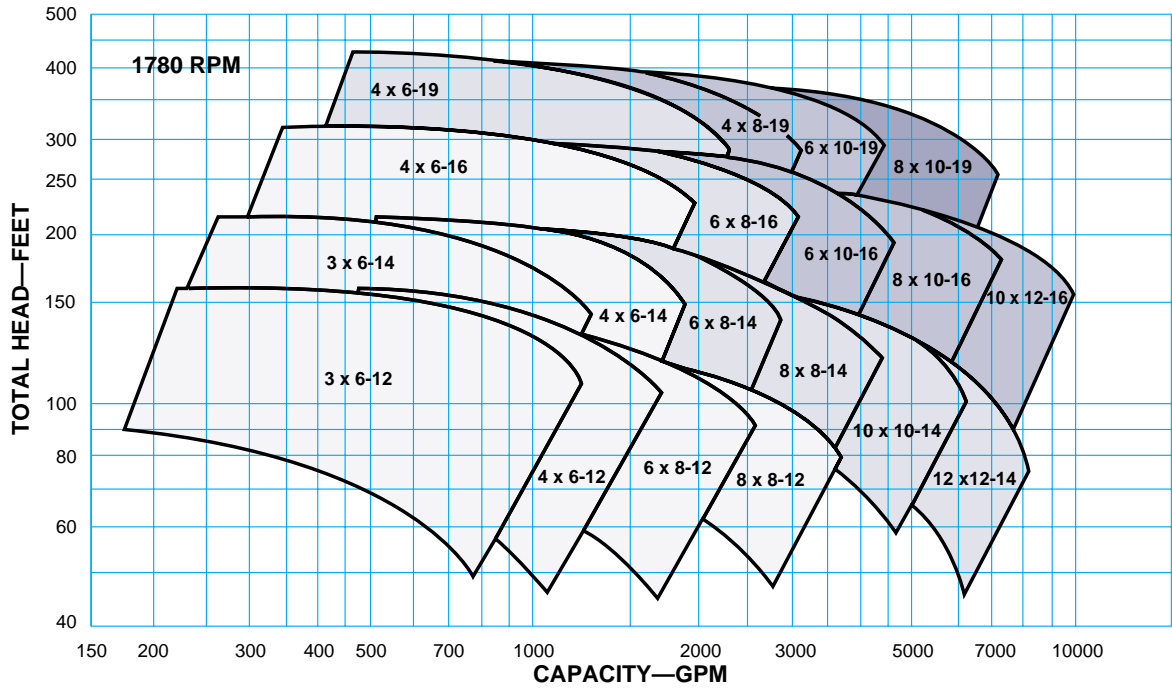

Parts List and Materials of Construction

Item Number	Part Name	Material				
		All Iron/SS Impeller	All Iron/SS Impeller, SS Sideplate	All 316SS	All CD4MCuN	All 317SS
100	Casing	Cast Iron	Cast Iron	316SS	CD4MCuN	317SS
101	Impeller ¹	316SS	316SS	316SS	CD4MCuN	317SS
105	Lantern Ring	Teflon [®]				
106	Packing	Teflon [®] Impregnated Fibers				
107	Gland	316SS				
108	Frame Adapter ²	Ductile Iron				
112	Thrust Bearing	Duplex Angular Contact				
122	Shaft	Carbon Steel (4340)				
126	Shaft Sleeve	316SS	316SS	316SS	316SS	317SS
126A	Shearceller™ Sleeve	N/A	Carbon-filled Teflon			N/A
134A	Bearing Housing	Cast Iron				
136	Bearing Locknut and Lockwasher	Steel				
159	Seal Chamber (Mechanical Seal)	Cast Iron	Cast Iron	316SS	CD4MCuN	317SS
164	Case Wear Ring (Enclosed Impeller)	316SS	316SS	316SS	CD4MCuN	317SS
176	Suction Sideplate (Open Impeller)	Cast Iron	316SS	316SS	CD4MCuN	317SS
178	Impeller Key	AISI 303				
184	Stuffing Box Cover (Packed Box)	Cast Iron	Cast Iron	316SS	CD4MCuN	317SS
184A	Stuffing Box Cover (Dynamic Seal Option)	316SS	316SS	316SS	CD4MCuN	317SS
202	Impeller Wear Ring (Enclosed Impeller) ³	316SS	316SS	316SS	CD4MCuN	317SS
228	Bearing Frame	Cast Iron				
262	Repeller (Dynamic Seal Option)	316SS	316SS	316SS	CD4MCuN	317SS
304	Impeller Nut	316SS	316SS	316SS	CD4MCuN	317SS
332A	Labyrinth Seal, Outboard	Bronze				
333A	Labyrinth Seal, Inboard	Bronze				
351	Casing Gasket	Aramid Fiber with EPDM Rubber				
353	Mechanical Seal	As Required				
356E	Stud, Casing Wear Ring	304SS				
357A	Nut, Casing Wear Ring	304SS				
358	Casing Drain Plug	Carbon Steel	Carbon Steel	316SS	Alloy 20	317SS
360P	Sideplate/Wear Ring-to-Casing Gasket	Aramid Fiber with EPDM Rubber				
370A	Hex Cap Screw, Adapter to Casing	Carbon Steel				
409	Radial Bearing	Cylindrical Roller ⁴ Single Row Deep Groove ⁵				
412A	O-ring, Impeller	Teflon [®]				
412C	O-ring, Sideplate-to-Casing	Viton [®]				
412F	O-ring, Sleeve	Teflon [®]				
444	Backplate (Dynamic Seal Option)	316SS	316SS	316SS	CD4MCuN	317SS
496	O-ring, Bearing Housing	Buna				
748	Casing Lug ⁶	Ductile Iron				
761B	1-ALERT Condition Monitor	Stainless Steel/Epoxy				

Notes: ¹Shearceller™ available only in Duplex 2205. ²Available on S, M, L, XL only ³Available on XL1, XL2-S, XL2 only

Material	ASTM	Approximate Equivalent Standards		
		DIN	JIS	ISO
Ductile Iron	A536 Gr 60-40-18	0.7043	G5502 FCD40	R1083/400-12
Cast Iron	A48 Class 30B	0.6020	G551 FC20	DR185/Gr200
316SS	A743 CF-8M	1.4408	G5121 SCS14	
317SS	A743 CG-8M	1.4448		
CD4MCuN	A890 GR1B CD4MCuN	1.4517		
Alloy 20	A743 CN-7M	1.4536		
Duplex 2205	A240	1.4462		



Sectional View

S, M, L and XL

Mechanical Seal Option

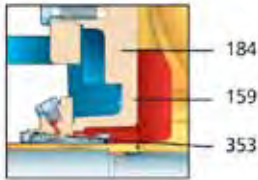

Enclosed Impeller Option

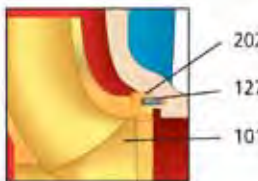

Shearpeller™

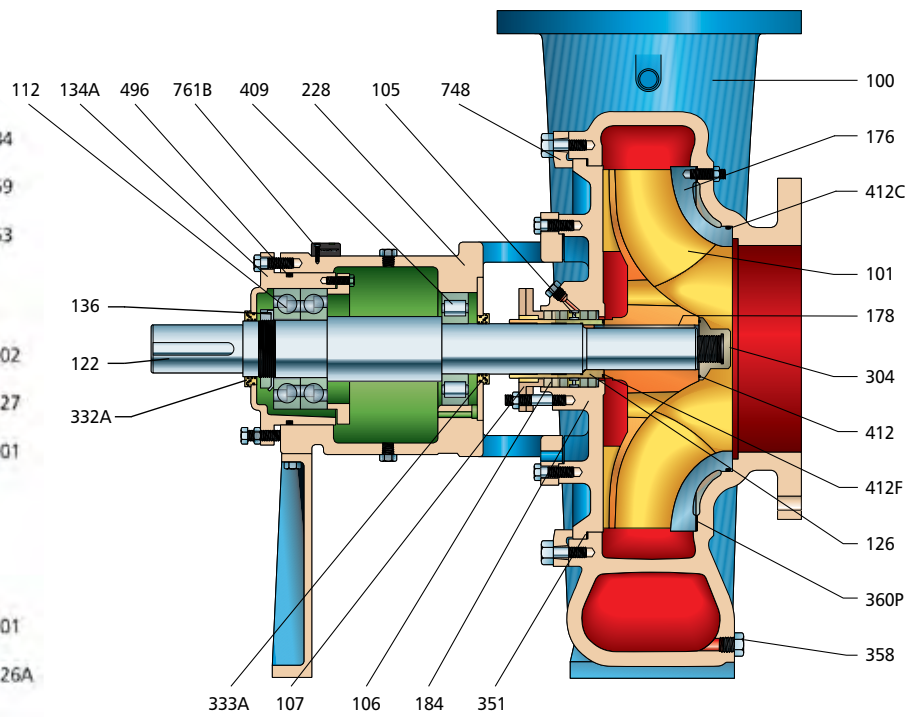

Illustrated:

- Packed Stuffing Box
- Oil Lubrication
- Open Impeller

XL1, XL2-S and XL2

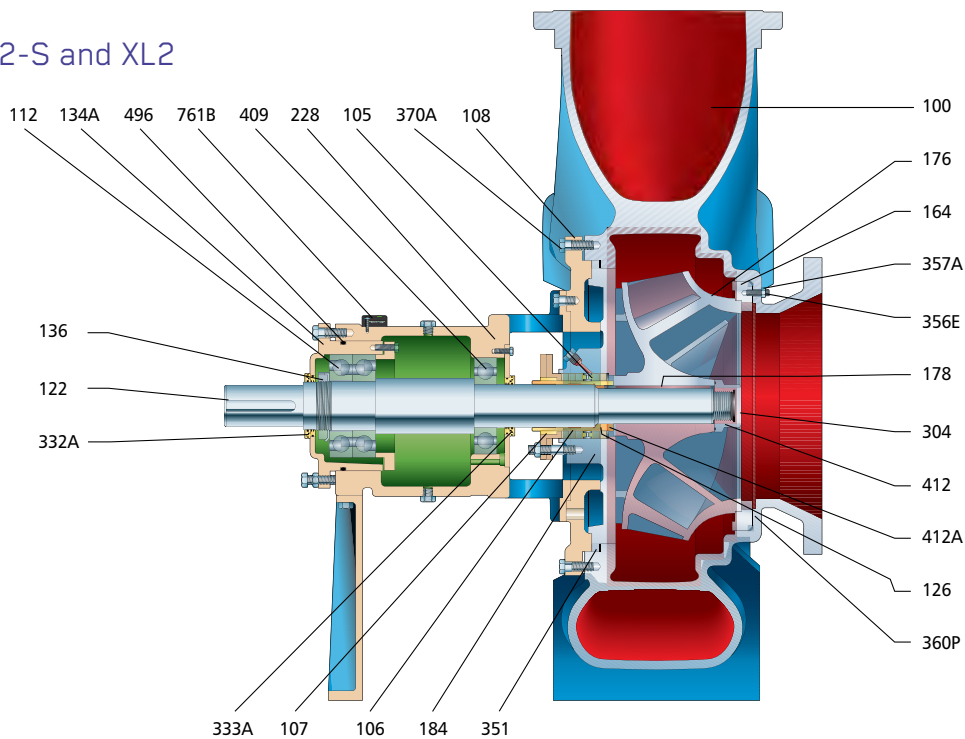

Illustrated:

- Packed Stuffing Box
- Oil Lubrication
- Open Impeller

Dimensions

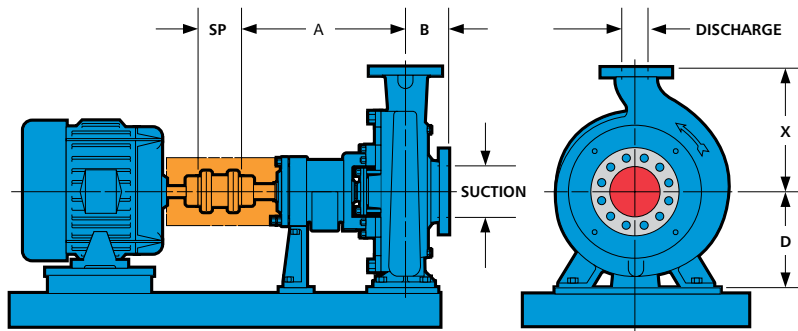

DIMENSIONS									
Group	Size	Discharge	Suction	D	X	B	A	SP (minimum)	Pump Weight- Pounds
S	3X6-12	3	6	9.84	12.40	4.92	20.87	5.51	368
	4X6-12	4	6	9.84	13.98	5.51	20.87	5.51	389
	6X8-12	6	8	11.02	14.76	6.30	20.87	5.51	520
	8X8-12	8	8	12.40	16.73	7.87	20.87	5.51	650
	3X6-14	3	6	9.84	12.40	4.94	20.87	5.51	468
	4X6-14	4	6	11.02	13.98	5.51	20.87	5.51	503
	4X6-16	4	6	12.40	15.75	5.51	20.87	5.51	566
M	6X8-14	6	8	12.40	15.75	6.30	26.38	7.09	545
	8X8-14	8	8	12.40	17.72	7.09	26.38	7.09	620
	10X10-14	10	10	13.98	18.70	8.86	26.38	7.09	773
	12X12-14	12	12	16.73	22.05	9.84	26.38	7.09	922
	6X8-16	6	8	12.40	17.72	6.30	26.38	7.09	626
	4X6-19	4	6	12.40	16.73	6.30	26.38	7.09	672
L	6X10-16	6	10	13.98	19.69	7.09	29.53	7.09	821
	8X10-16	8	10	16.73	19.69	8.86	29.53	7.09	913
	10X12-16	10	12	16.73	23.62	10.43	29.53	7.09	1077
	14X14-16	14	14	19.69	26.38	11.04	29.53	7.09	1336
	4X8-19	4	8	13.98	17.72	6.30	29.53	7.09	700
	6X10-19	6	10	13.98	19.69	7.09	29.53	7.09	926
	8X10-19	8	10	16.73	22.05	7.87	29.53	7.09	994
	10X12-19	10	12	16.73	23.62	9.84	29.53	7.09	1133
	6X10-22	6	10	16.73	22.05	7.09	29.53	7.09	1087
8X10-22	8	10	16.73	23.62	8.86	29.53	7.09	1198	
XL	12X14-19	12	14	19.69	26.38	11.02	32.68	9.84	1538
	16X16-19	16	16	22.05	29.53	11.81	33.46	9.84	1846
	10X12-22	10	12	19.69	26.38	8.86	32.68	9.84	1451
	12X14-22	12	14	22.05	26.38	10.43	32.68	9.84	1682
	14X16-22	14	16	24.80	29.53	13.19	32.68	9.84	2018
	18X18-22	18	18	24.80	33.46	13.98	33.46	9.84	2321
	6X10-25	6	10	16.73	22.05	7.87	32.68	9.84	1389
	8X12-25	8	12	19.69	24.80	8.86	32.68	9.84	1515
	10X14-25	10	14	22.05	29.53	9.84	32.68	9.84	1688
	20X20-25	20	20	29.53	39.37	15.75	33.46	9.84	2681
XL1	14X16-27	14	16	23.62	40	14.76	48.89	14.00	4313
	24X24-27	24	24	33.46	43.13	19.37	49.25	17.88	6040
	20X24-29	20	24	31.02	42.12	17.50	49.75	18.88	6525
XL2-S	20X24-31	20	24	33.47	43.31	17	56.25	16.5	7066
XL2	24X30-35	24	30	37.80	51.18	21.25	57.41	23.5	11,725
	24X30-35A	24	30	37.80	51.18	21.25	57.41	23.5	11,531
	24X30-35N	24	30	37.80	51.18	21.25	57.41	23.5	11,734
	30X30-41	30	30	43.31	67	24	58.16	23.5	15,525

All dimensions in inches and (mm). Not to be used for construction.

Construction Details

		S Group	M Group	L Group	XL Group
Temperature Limits	Grease Lube	355° F	355° F	355° F	355° F
	Oil Lube w/o cooling	355° F	355° F	355° F	355° F
	Oil Lube w/cooling	445° F	445° F	445° F	445° F
Shaft Diameters (inches)	At Impeller	1.51	1.77	2.20	2.60
	Under Shaft Sleeve	1.97	2.28	2.68	3.15
	At Coupling	1.625	1.875	2.375	2.875
	Between Bearings	2.63	2.88	3.39	4.06
Packed Stuffing Box (inches)	Bore	3.35	3.74	4.13	4.72
	Depth	3.35	3.35	3.54	3.54
	Packing Size	1/2	1/2	1/2	1/2
	# of Packing Rings	5	5	5	5
	Width of Lantern Ring	5/8	5/8	3/4	3/4
	Distance to 1st Obstruction	2.26	3.14	2.76	3.24
	Sleeve Diameter	2.362	2.756	3.150	3.738
Mechanical Seal Chamber (inches)	Bore	3.37	3.88	4.49	5
	Depth to VPE ring	1.81	2.40	2.15	2.15
	Distance to 1st Obstruction	2.89	3.64	3.46	3.98
	Sleeve Diameter	2.375	2.75	3.25	3.75

		XL1 Group			XL2-S Group	XL2 Group	
		14X16-27	20X24-29	24X24-27	20X24-31	20X24-35 20X24-35 A 20X24-35 N	30X30-41
Temperature Limits	Oil Lube w/o cooling	355° F					
	Oil Lube w/cooling	445° F					
Shaft Diameters (inches)	At Impeller	3.937				4.921	
	Under Shaft Sleeve	4.625			5.750		
	At Coupling	4.125			5.125		
	Between Bearings	5.51			6.69		
Packed Stuffing Box (inches)	Sleeve Diameter	5.315			6.496		
	Bore	6.30			7.48		
	Depth	3.54			3.54		
	Packing Size	1/2 X 1/2			1/2 X 1/2		
	# of Packing Rings	5			5		
	Width of Lantern Ring	3/4			3/4		
	Distance to 1st Obstruction	7.33			8.70		
Mechanical Seal Chamber (inches)	Sleeve Diameter	5.250			6.250		
	Depth	3.06			3.16		
	Distance to 1st Obstruction	7.33			8.70		
Tape Bore™ Seal Chamber (inches)	Bore	6.69			7.87		
	Depth to VPE ring	5.25			5.75		
	Distance to 1st Obstruction	6.10			6.82		
	Depth to VPE ring	4.00			4.50		

Modular Interchangeability

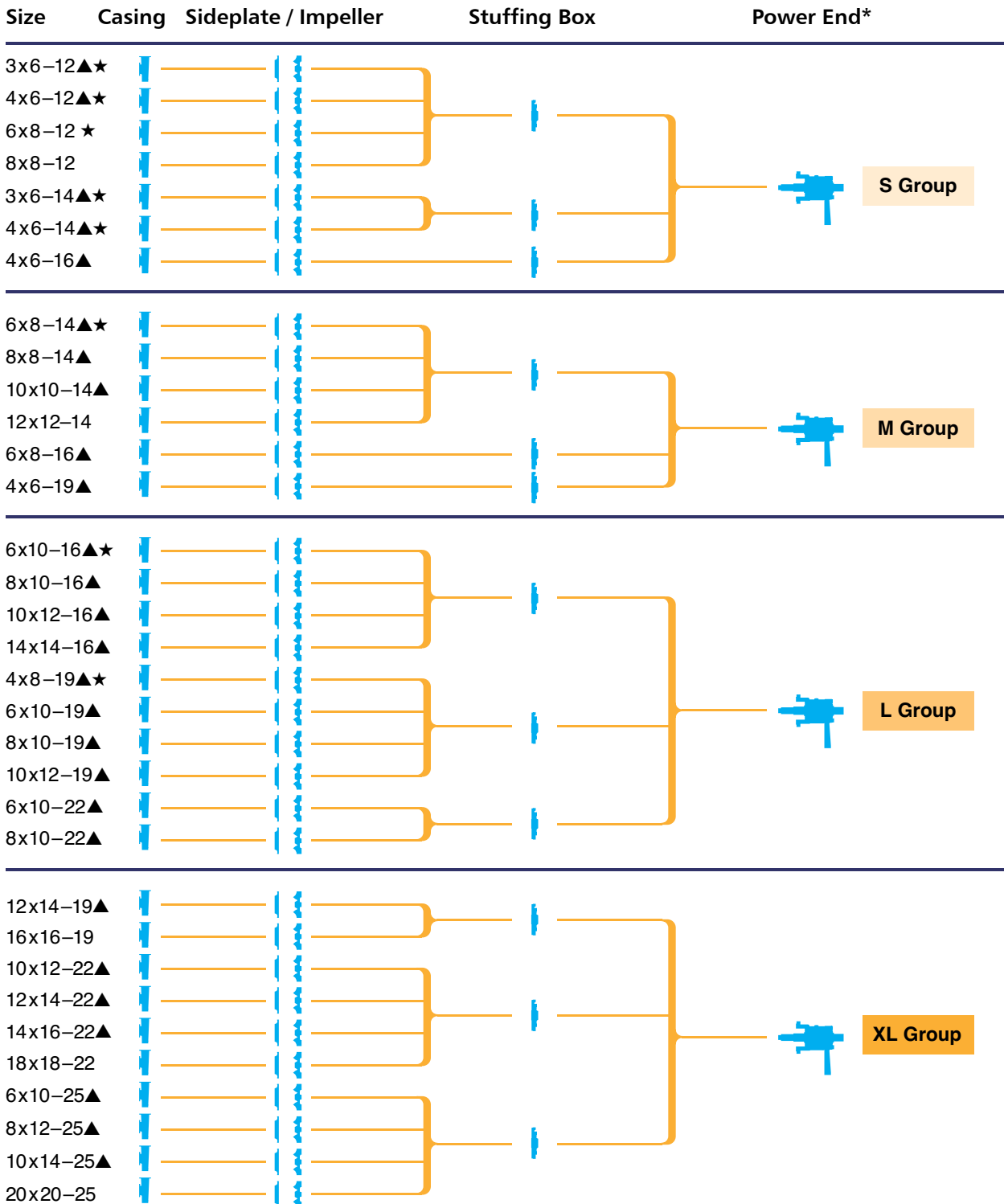

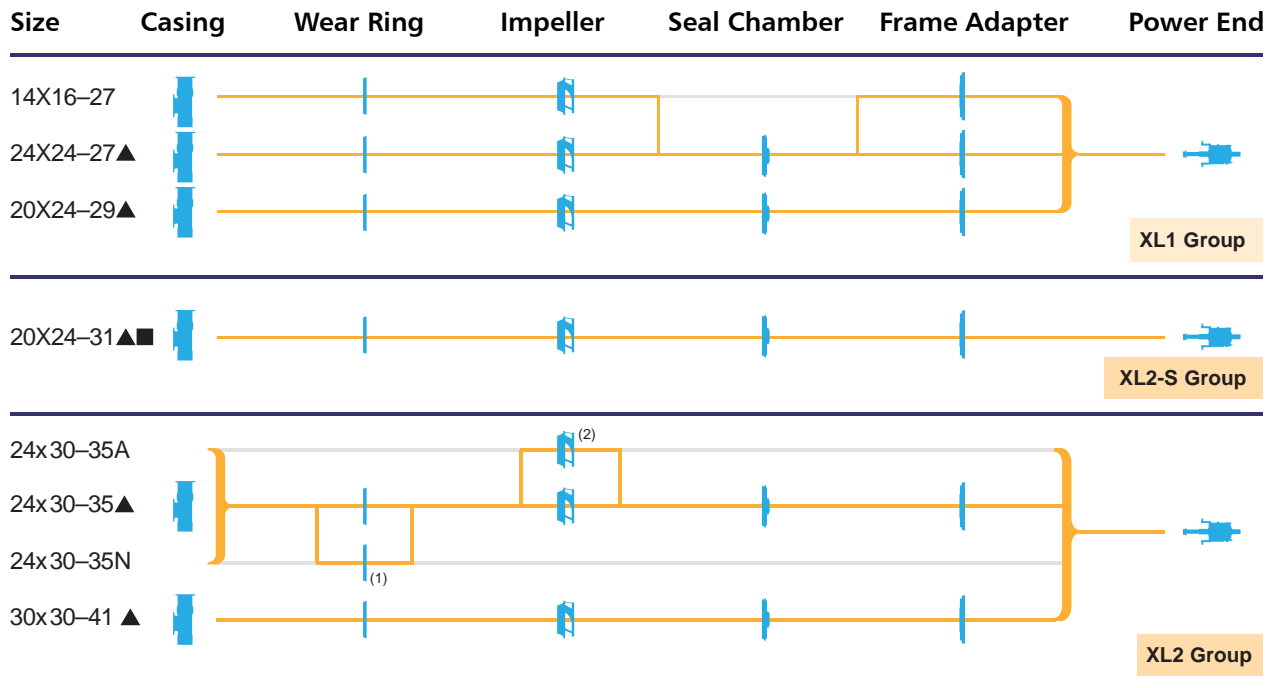

* Shafts for Models 3180 and 3185 are not interchangeable.
 Sleeves for mechanical seals on the 3180 and 3185 are not interchangeable.
 ▲ Available with enclosed impeller.

★ Available with Shearpeller™
 ■ Uses the XL2-S shaft, sleeve and impeller nut.
 (1) 24X30 - 35N uses alternate wear ring
 (2) 24X30 - 35A uses alternate impeller

Pick Your Perfect Process Pump

Whether it's for pumping severe corrosives, abrasive slurries, fibrous / stringy solids, high temperature liquids, hazardous fluids, low flow or high capacity services – Goulds has a perfect, reliable solution. The Goulds selection of pump solutions includes horizontal and vertical configurations in a range of alloy and non-metallic constructions, sealed and sealless.



Goulds 3181 / 3186



- Capacities to 13,000 GPM (3,000 m³/h)
- Heads to 410 feet (125 m)
- Temperatures to 508° F (300° C)
- Pressures to 360 PSIG (25 bar)

World-Class Pump Line

Model 3181

- ANSI Class 300 flange drilling
- Inch-dimensioned OD of mechanical seal sleeve
- Inch-dimensioned bearing locknut
- Inch-dimensioned coupling extension

Model 3186

- ISO or JIS 40 bar flange drilling
- mm-dimensioned OD of mechanical seal sleeve
- mm-dimensioned bearing locknut
- mm-dimensioned coupling extension

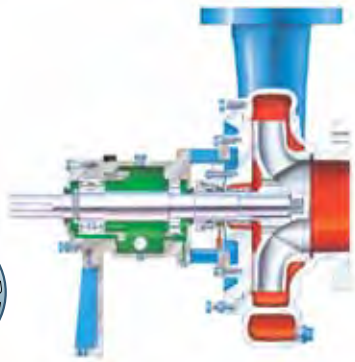

Designed to Handle High Temperature and High Pressure Services of the Pulp and Paper Industries

- **Hydraulic Coverage:** Line designed for full 50 / 60 Hz performance.
- **Back Pull-Out Construction:** Spacer type coupling allows one-craft maintenance.
- **Centerline Supported:** High temperature stability.
- **Labyrinth Seals:** Eliminate loss of lubricant, prevent lubricant contamination for maximum bearing life.
- **Maximum Interchangeability:** Power end and impellers completely interchangeable with Goulds Models 3180 or 3185.
- **International Design:** Metric fasteners and fittings used throughout.

Services

- Digester recirculation
- Make-up liquor
- White liquor
- Black liquor
- High pressure / high temperature pulp mill services
- Hot oil

For High Pressure / Temperature Services

- Centerline mounted
- Fully-confined spiral wound-casing basket
- Through bolted seal chamber

World-class Paper Stock and Medium Consistency Products

Goulds offers users a variety of options to meet specific plant and process requirements.

Standpipe Arrangement with ClO₂ Mixing

Stock from washers and mixers feed special Goulds standpipes that are reverse tapered to prevent stock bridging. Systems include controls for vacuum, dilution, level and flow, ClO₂ Optimix™ mixer and chemical injection pipe are included.

Tower Bottom Arrangement

Stock from bleach / storage towers falls into Goulds feed chute connected to the tower with expansion joint and isolation valve. Depending on tower level and consistency a vacuum pump may not be required.

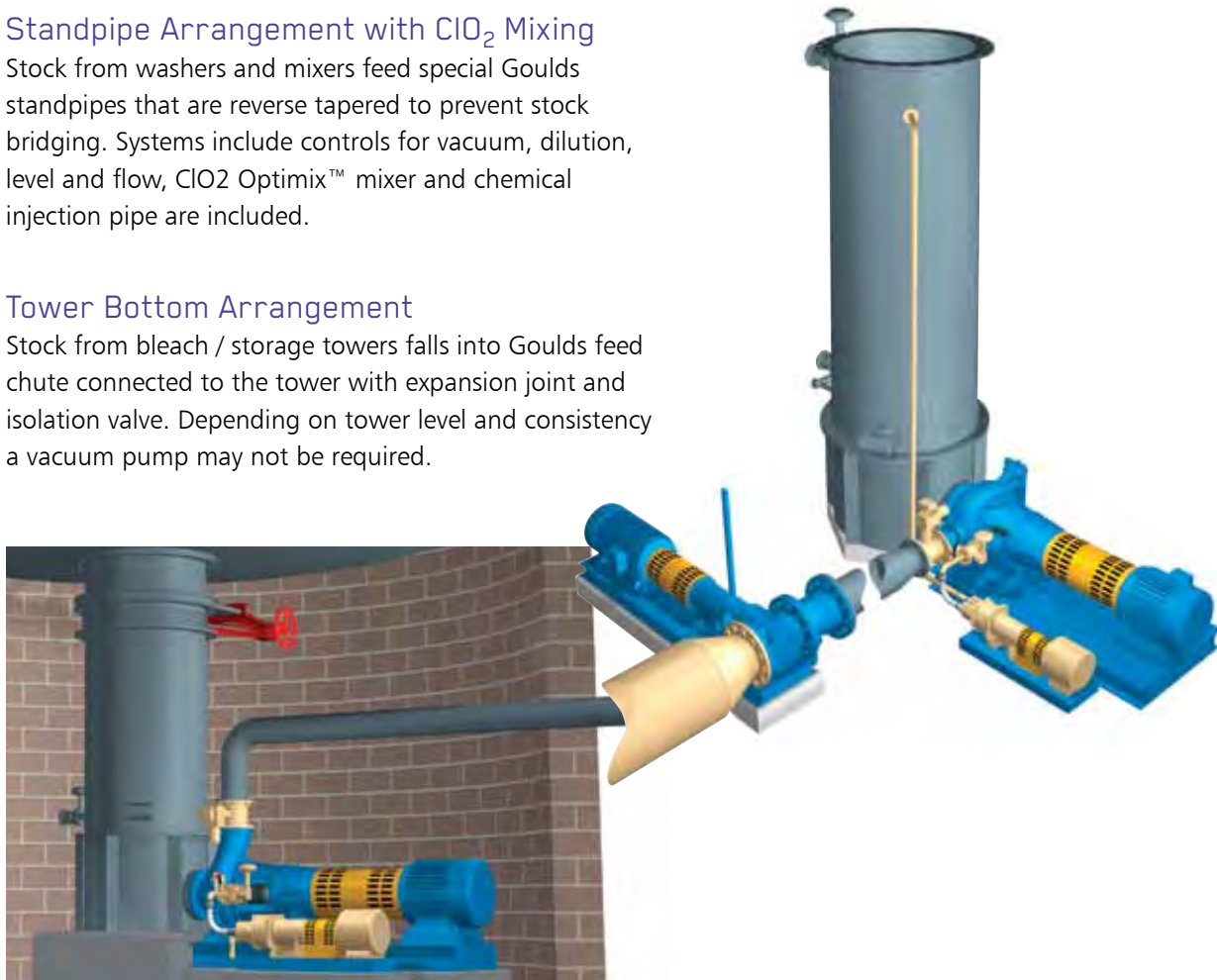

Booster Arrangement

Goulds booster pump will increase pressure, but does not require standpipe or degassing system.



Visit our website at
www.gouldspumps.com

PRO



services

Reliability has no quitting time.

Building on over 160 years of Goulds Pumps experience, **PRO Services** provides an array of services focused on reducing equipment total cost of ownership (TCO) and increasing plant output, including predictive monitoring, maintenance contracts, field service, engineered upgrades, inventory management, and overhauls for pumps and other rotating equipment.



Parts & Inventory

- Efficient and timely parts supply
- Engineered parts for obsolete equipment (ProCast)
- Reverse engineering and rapid pattern manufacturing
- Inventory analysis and management
- Replacement pumps
- Goulds Pumps parts

Plant Performance

- Equipment monitoring and control products and services to improve system reliability and up-time
- Full service maintenance contracts
- ITT on-site experts identify and resolve bad actor equipment issues through:
 - Root cause failure analysis
 - Energy performance audits and improvements
 - Maintenance, operator and management training

Repair & Upgrades

- Repair to OEM standards
- Field service
- Scheduled maintenance and plant shutdowns
- Engineered drop-in replacements
- Upgrades:
 - Upgrade pumps to the latest API standard editions
 - Hydraulic re-rates to operate pumps at the customer's required setting
 - Mechanical & material upgrades



ENGINEERED FOR LIFE

240 Fall Street
Seneca Falls, NY 13148
www.itt.com

© 2014 Goulds Pumps, Incorporated
A subsidiary of ITT Corporation

Form B3180i-ALERT 05/14