



# Goulds 7200CB

API 610 11<sup>th</sup> Edition / ISO 13709 2<sup>nd</sup> Edition

API BB5 Barrel Multistage, Radially Split

In-Line Diffuser Type



# ITT

ENGINEERED FOR LIFE

# Proven API Leadership

## Complete API Offering

- Over 20,000 units installed
- Over 3,000 between bearing pumps installed
- 40+ years of API expertise

## Global Coverage

ITT Goulds Pumps has the global coverage needed to serve multi-national companies in any region.

## Industry Leading Hydraulic Coverage

- We offer extensive coverage to meet your process needs.
- Better hydraulic fits can mean improved efficiency and long-term reliability and parts life.

## 8000 HP / 6000 kW Testing Capability

- Our expanded test facility can test your pump in the most demanding conditions.
- Testing at rated speeds is critical to access the impact of dynamic conditions including vibration.

## API Engineering Expertise

- We package engineered pumps to meet your demanding applications — that fully conform to the latest API specifications.
- Engineered Packaging with a wide range of drivers, seals, piping, nozzle conformance, flanges, baseplates and QC testing.
- ITT is a world leader in technology and engineering, including hydraulics, materials science, mechanical design and fluid dynamics.



# Goulds 7200CB

## Goulds 7200CB

High Temperature, High Pressure Low Specific Gravity BB5 Barrel Pumps for Critical Services.

- Capacity to 4,000 GPM (910 m<sup>3</sup>/h)
- Total Dynamic Head to 9,000 feet (2740 m)
- Temperature to 800° F (425° C)
- Pressure to 4,000 PSIG (275 Bar)
- Operating Speeds to 6,000 RPM



## Goulds API Portfolio



Goulds 3700



Goulds 3600



Goulds 3610



Goulds 3620



Goulds 3640

API Type	Goulds Model	Capacity GPM (M <sup>3</sup> /Hour)	TDH Feet (Meters)	Temperature °F (°C)	Pressure PSIG (kg/cm <sup>2</sup> )
OH-2	3700	8500 (1930)	1200 (360)	800 (425)	870 (60)
OH-3	3910	6000 (1360)	750 (230)	650 (340)	600 (42)
BB-1	3610	50000 (11355)	700 (215)	300 (150)	300 (21)
BB-2	3640	7500 (1700)	2500 (760)	850 (455)	1130 (75)
BB-2	3620	20000 (4540)	1500 (455)	850 (455)	1000 (70)
BB-3	3600	8500 (1930)	9000 (2740)	400 (205)	4000 (275)
<b>BB-5</b>	<b>7200CB</b>	<b>4000 (910)</b>	<b>9000 (2740)</b>	<b>800 (425)</b>	<b>4000 (275)</b>
VS4	API 3171	3180 (720)	525 (160)	450 (232)	750 (50)
VS1	VIT	70000 (14760)	3500 (1060)	500 (260)	2500 (175)

# Trusted Technology

Model CB upgraded to 11th edition. Over 30 years of successful installations.

## Proven Reliability

Properly designed balance drums are critical to a BB5 pump's reliable control of axial thrust forces. We exhaustively test the pumps over the allowable flow range and over the range of allowable wear clearances (1x to 2x clearances) to determine the range of axial thrust forces to properly size the balance drum. The result is reliable operation over the range of allowable conditions.

## Easy Maintenance

For Model 7200CB pumps, customers can quickly dismantle and remove the complete cartridge using our BB5 cradle tool. The pump casing and nozzles remain connected to speed removal.



## World Class Hydraulics

There are two sets of curves available. One set is optimized for maximum head-per-stage while a second set is optimized for maximum efficiency.

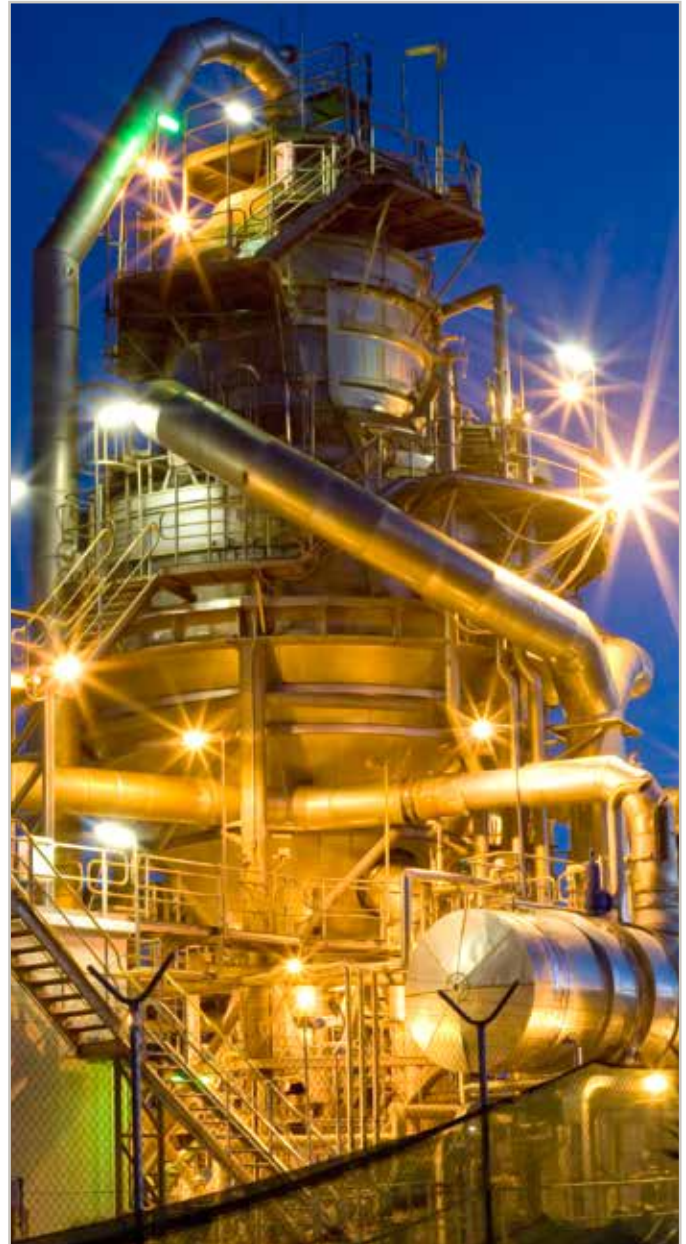
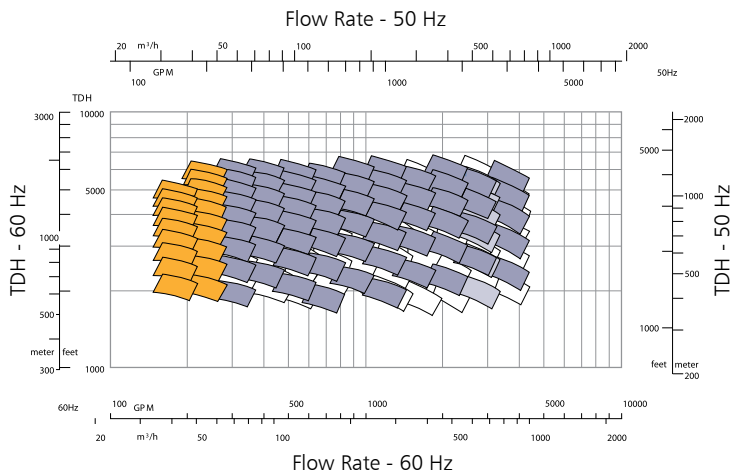
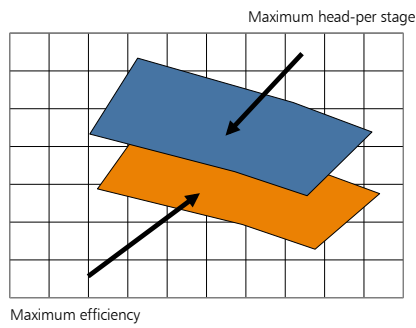

# Goulds 7200CB

API 610 11<sup>th</sup> Edition / ISO 13709 2<sup>nd</sup> Edition

API BB5 Barrel Multistage, Radially Split  
In-Line Diffuser Type

## Impeller Arrangements

In-line diffuser type design.

## Diffusers / Impellers

Metal to metal stage casing fits. Key and shrink fit impellers secured against movement in both directions.

## Fully-Shrouded Diffuser Standard

Increases reliability by nearly eliminating diffuser fatigue.

## Low Vibration Design

Precision investment impeller casting, dynamically balanced rotor for low vibration.

## Robust Rotor Design

With large stepped shaft and high L3 / D4 ratios.

## Pull-Out Cartridge Assembly

Stage casings sealed by discharge pressure. Cartridge removed on larger pumps, cartridge assembled.

## Barrel Outer Casing

Centerline mount, radial split, full diameter pressure. Cast barrel and nozzles. (nozzle locations / orientation available)

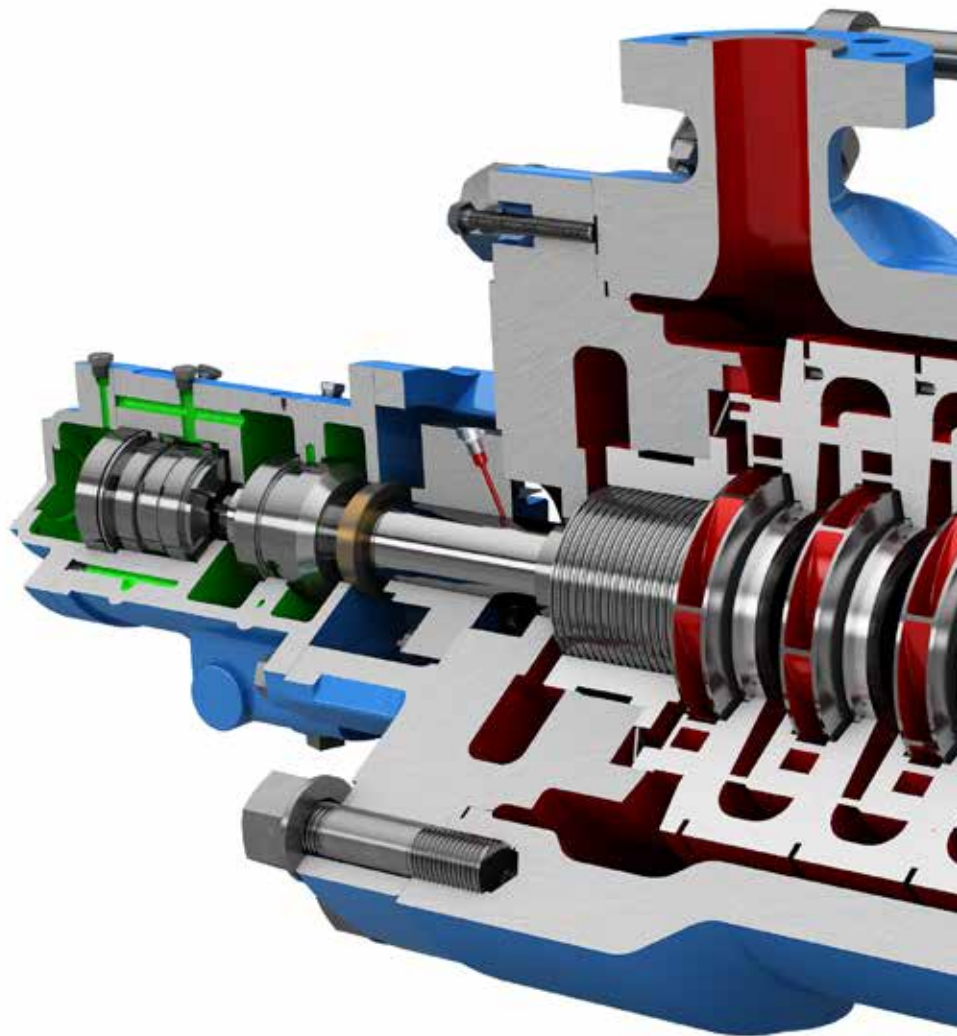

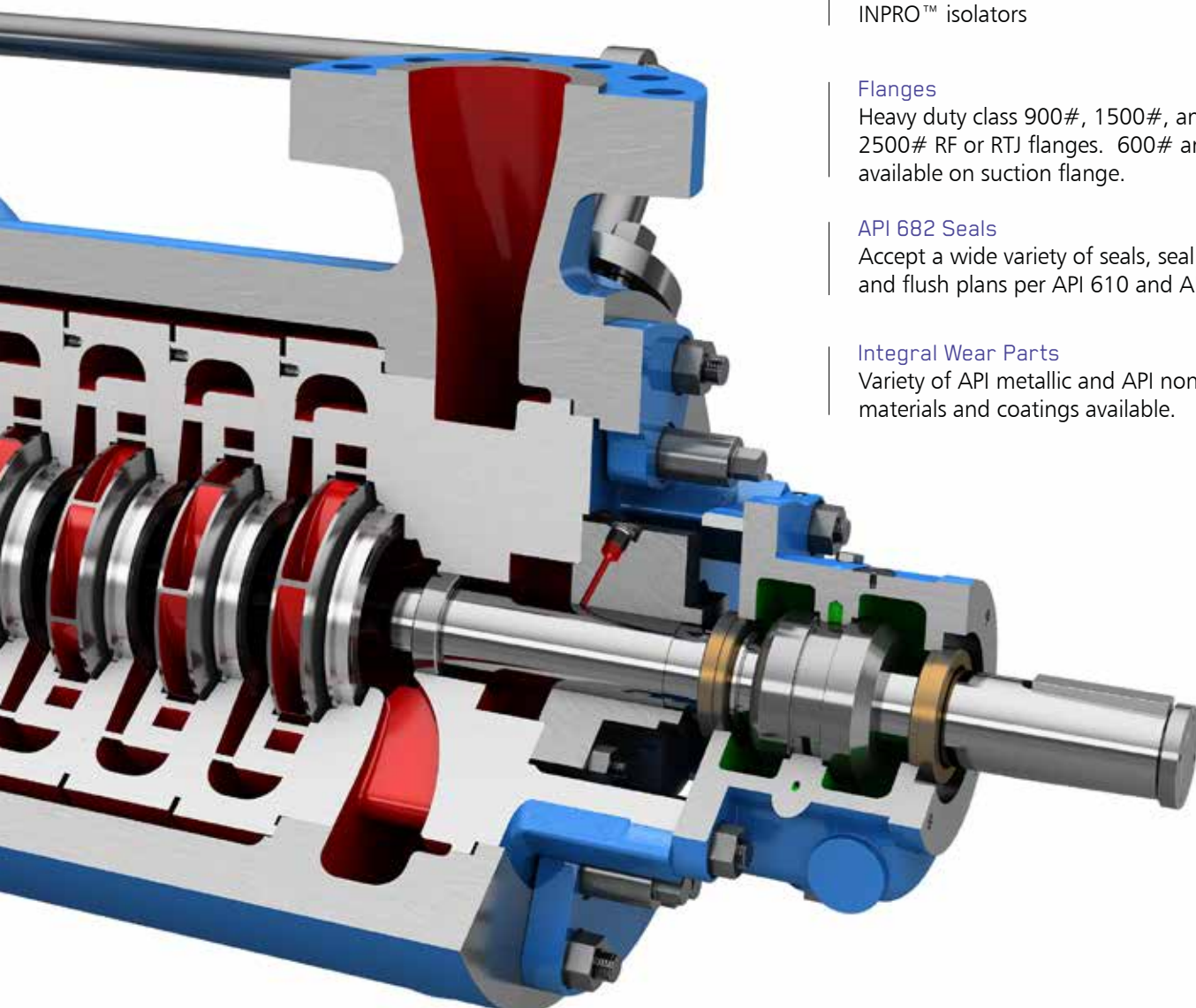

#### Balance Drum

Designed over allowable flow range and clearances to reliably balance axial forces.

#### Rigid 360° Bearing Bracket

Ball radial and duplex thrust. Pressure lubricated sleeve radial / tilting pad thrust. INPRO™ isolators

#### Flanges

Heavy duty class 900#, 1500#, and 2500# RF or RTJ flanges. 600# and 900# available on suction flange.

#### API 682 Seals

Accept a wide variety of seals, seal options and flush plans per API 610 and API 682.

#### Integral Wear Parts

Variety of API metallic and API non-metallic materials and coatings available.



# Proven Service Experience

## Hydraulic Rerates

Processes often change over time – causing pumps to run far from best efficiency point (BEP) with the associated reduction in reliability (MTBF).

We can perform a “hydraulic rerate” to your existing BB5 pump – moving the BEP to the left without any hydraulic changes. The modified pump’s operation is closer to the BEP with increased efficiency and reliability.



## Drop-In Replacements

Our drop-in replacements allow you to get a new BB5 pump without replacing your existing piping and baseplate – saving you \$10,000s in site costs while reducing emissions and improving MTBF.

We customize our BB5 casing nozzles and/or foot locations, offering you the best of both worlds – new pump with existing piping and site work.



## Engineered Upgrades for All Brands

Older pumps don't comply with the more stringent latest editions of API. This causes many issues ranging from limited use of latest seal designs (API 682), potential seal emissions issues, poor reliability and MTBF, OEM parts becoming obsolete, and more. We perform engineered upgrades to your existing API Pump (any brand) - upgrading the power end, casing cover, shaft and seals to the latest API standards.

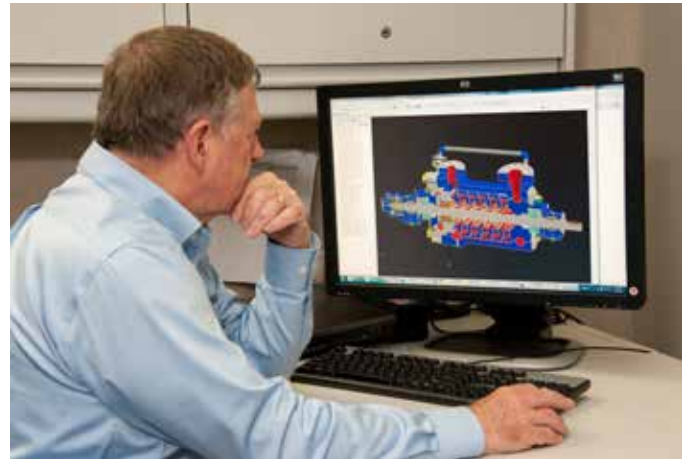

# A Leader in API Engineered Pump Package Solutions

## API Family of Pumps

Model 3700  
OH-2



Model 3910  
OH-3

Model 3620  
3640  
BB-2



Model 3610  
BB-1



API Type	Goulds Model	Capacity GPM (M <sup>3</sup> /Hour)	TDH Feet (Meters)	Temperature °F (°C)	Pressure PSIG (kg/cm <sup>2</sup> )
OH-2	3700	8500 (1930)	1200 (360)	800 (425)	870 (60)
OH-3	3910	6000 (1360)	750 (230)	650 (340)	600 (42)
BB-1	3610	50000 (11355)	700 (215)	300 (150)	300 (21)
BB-2	3640	7500 (1700)	2500 (760)	850 (455)	1130 (75)
BB-2	3620	20000 (4540)	1500 (455)	850 (455)	1000 (70)
BB-3	3600	8500 (1930)	9000 (2740)	400 (205)	4000 (275)
BB-5	7200CB	4000 (910)	9000 (2740)	800 (425)	4000 (275)
VS4	API 3171	3180 (720)	525 (160)	450 (232)	750 (50)
VS1	VIT	70000 (14760)	3500 (1060)	500 (260)	2500 (175)
VS6	VIC	70000 (14760)	3500 (1060)	500 (260)	2500 (175)



Model 3600  
BB-3



Model 7200CB  
BB-5



Visit our website at  
www.gouldspumps.com

# Wherever you are, we're there too.

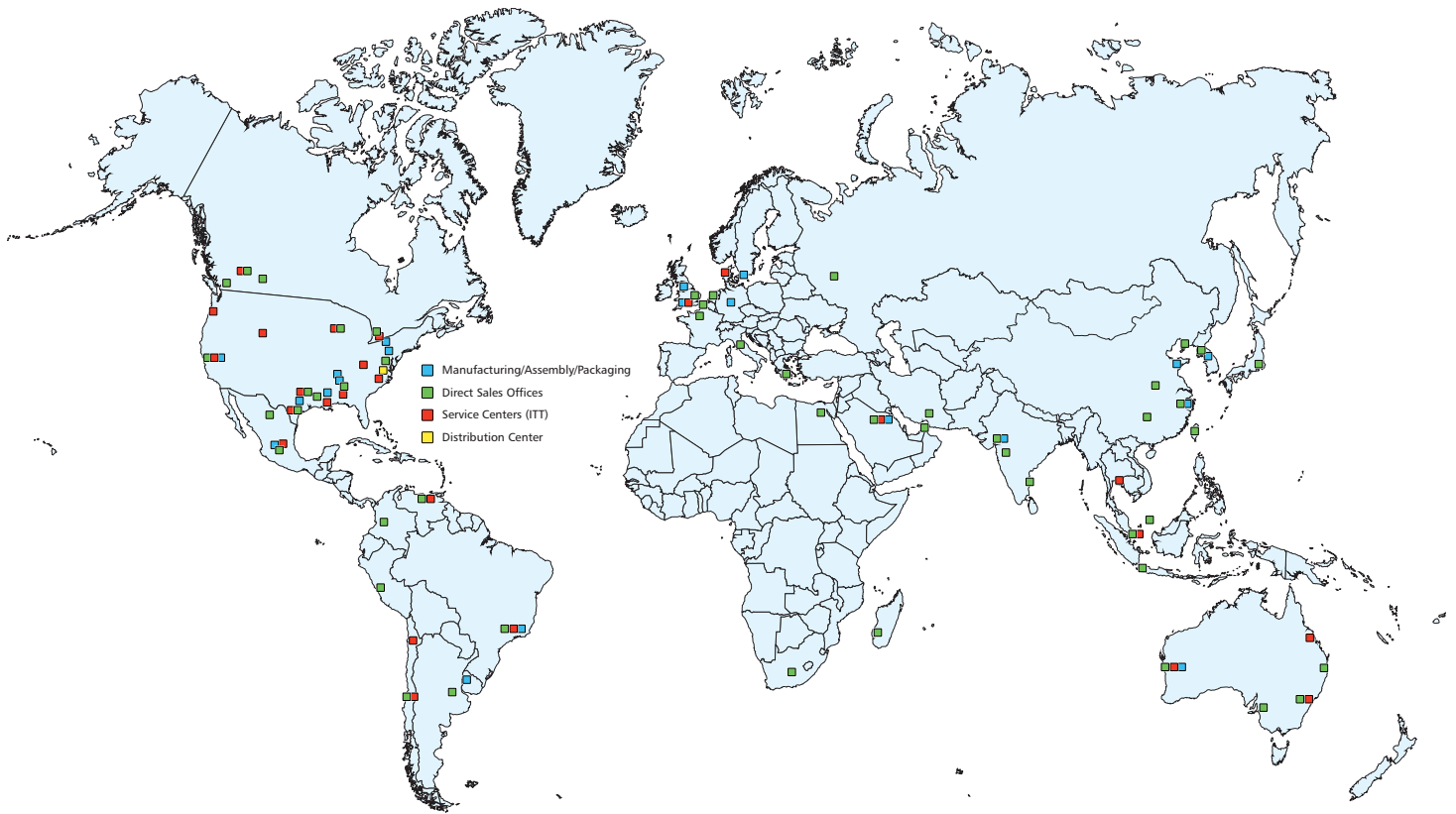

## PRO services

Reliability has no quitting time.

Building on over 160 years of Goulds Pumps experience, PRO Services provides an array of services focused on reducing equipment total cost of ownership (TCO) and increasing plant output, including predictive monitoring, maintenance contracts, field service, engineered upgrades, inventory management, and overhauls for pumps and other rotating equipment.

### Your Total Solution For Equipment Life Cycle Optimization

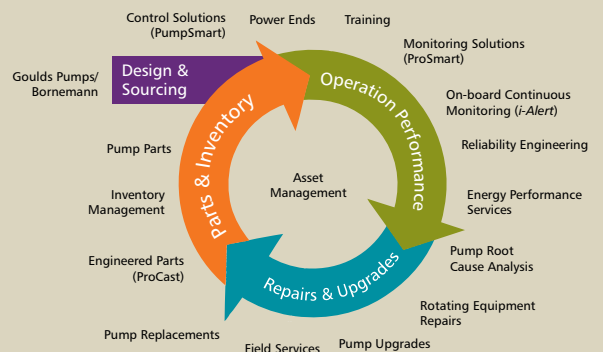

AUSTRALIAN DISTRIBUTOR



CALL 1300 789 466

When Pump Knowledge Matters  
www.kelairpumps.com.au