

 **GOULDS PUMPS**

Goulds AF

Axial Flow Pump



ITT

ENGINEERED FOR LIFE

Goulds AF

The Industry Leader in Circulating Pump Technologies



Cast design 6-36" (150-900 mm)



Fabricated design 42-66" (1050-1600 mm) (shown with optional spring mounted base)

Goulds line of Axial Flow pumps is unmatched in the industry for high volume/low head pumping requirements... especially when corrosive and/or abrasive solutions are involved. Extended service life, mechanical reliability, custom engineering, and a wide range of materials allow the Model AF to stand out as the leader in the field.

For continuous circulation of corrosive/abrasive solutions and process wastes. Proven performance in a variety of services around the world.

- Capacities to 300,000 GPM (68,000 m³/h)
- Heads to 30 feet (9.2 m)
- Low NPSH requirements
- Temperatures to 350° F (176°C)
- Available in cast iron, austenitic stainless steels, duplex alloys, nickel, nickel-chrome alloys, nickel-chrome-moly alloys, titanium, and other alloys as required for the service
- Available in 6-66", (150-1600 mm) sizes (larger sizes available)

Services:

- **Chemical** - evaporator and crystallizer circulation
- **Mining and Minerals** - phosphate, soda ash, potash, and sodium chloride processing
- **Petrochemical** - polypropylene reactors, xylene
- **Pulp & Paper** - black liquor evaporator, chlorine dioxide generators
- **Municipal** - sewage digesters
- **General** - raw water pumping, flood control, marine ballast transfer

Design Features

- Multiple Impeller selections for optimum performance and efficiency
- Tapered Bore Stuffing Box for longest mechanical seal life on cast sizes
- Dual lantern ring configuration available for packed stuffing box
- Back pullout construction standard on cast sizes
- Robust bearing frame and shaft for long life on critical, continuous duty services

Performance Features for Extended Pump Life



Labyrinth Seals

For maximum chemical resistance prevent premature bearing failure caused by lubricant contamination or loss of oil. Non-contracting unitized design for ease of maintenance assembly.

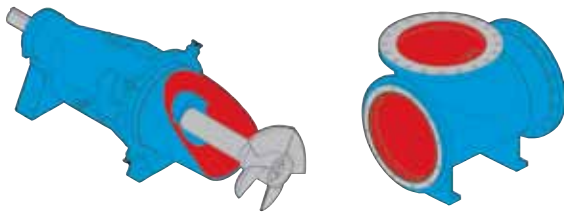

Back Pullout

Back pullout feature provided as standard on sizes through 36" (914 mm). Allows for ease of maintenance.

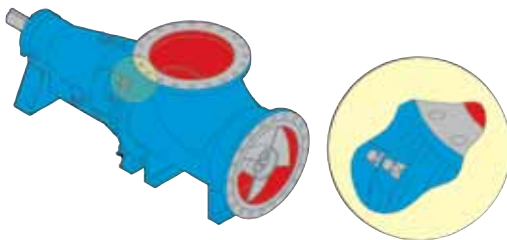

Adjusting Lugs for Ease of Adjustment

Adjusting bolts allow for precise, easy alignment of both the impeller clearance and stuffing box runout. Precise alignments minimize pump life cycle cost.

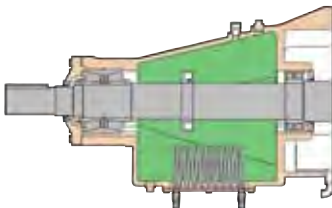

Oil Cooling

An oil cooling option is available on 12" and larger sizes to cool the oil bath. Used when process temperatures cause excessive heat build up in the bearing housing and or bearings..

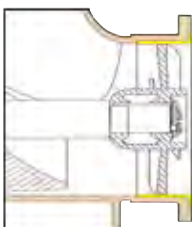

Elbow Liner

Precision-made replaceable liners between impeller and casing are offered as an option to ensure continuous high efficiency.



Taperbore Seal Chamber (cast sizes only)

Enlarged, tapered bore for increased life of mechanical seals through improved lubrication and cooling. Accommodates current cartridge designs.

Goulds AF

Rugged Design Features for Wide Range of Services

STANDARD LABYRINTH OIL SEALS

BI-DIRECTIONAL THRUST BEARING (6-36" sizes)

EXTRA LARGE OIL SUMP

Increased oil capacity provides better heat transfer for reduced oil temperature. Bearings run cooler and last longer.

FOUR-POINT MOUNTING

Decreases the effects of pipe load on the pump. (6-36" sizes)

EXTRA HEAVY DUTY SHAFT

Long bearing span and large diameters reduce shaft deflection, extend mechanical seal and bearing life.

STAINLESS DRIP PAN

Standard pan catches any drips and connects to drain piping to eliminate damage from leaks.

BUILT-IN ADJUSTING LUGS

Supplied as standard for ease of maintenance.

TAPER BORE STUFFING BOX (CAST SIZES ONLY)

Designed specifically for today's cartridge seals. Optional packed box with sleeve available. Fabricated sizes use a straight bore box for packing or mechanical seals.

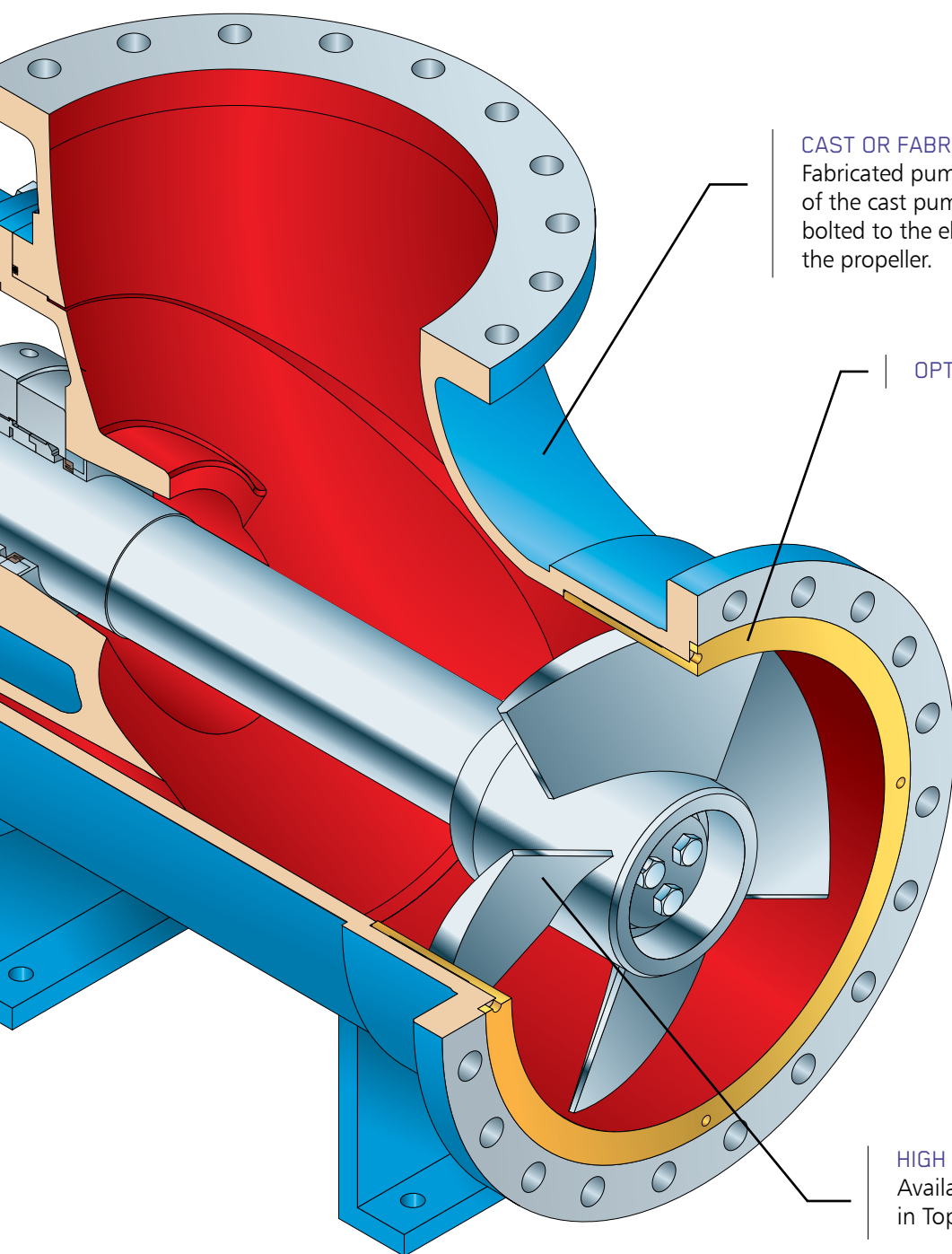

CAST OR FABRICATED ELBOWS

Fabricated pumps and some larger sizes of the cast pumps have a separate casing bolted to the elbow to simplify access to the propeller.

OPTIONAL REPLACEABLE LINE

HIGH EFFICIENCY IMPELLER

Available in multiple vane angles. Available in Top or End Suction configurations.

Construction Options

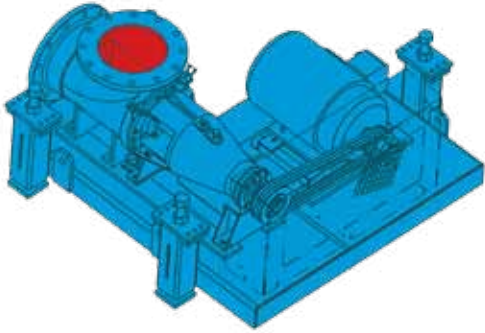

Spring Loaded Side by Side

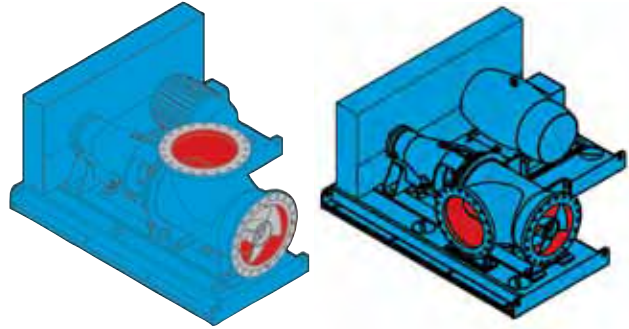

Side by Side

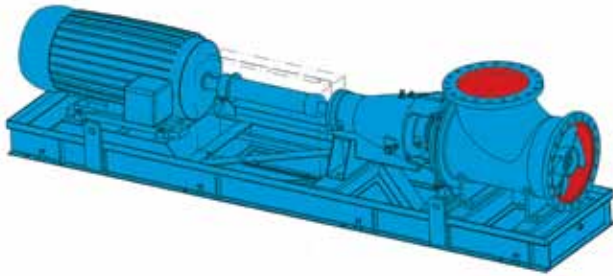

Direct Connected

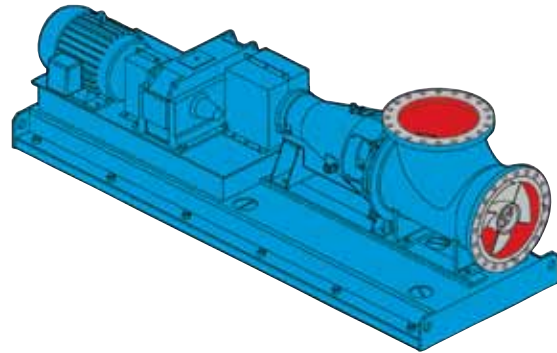

Gear Driven

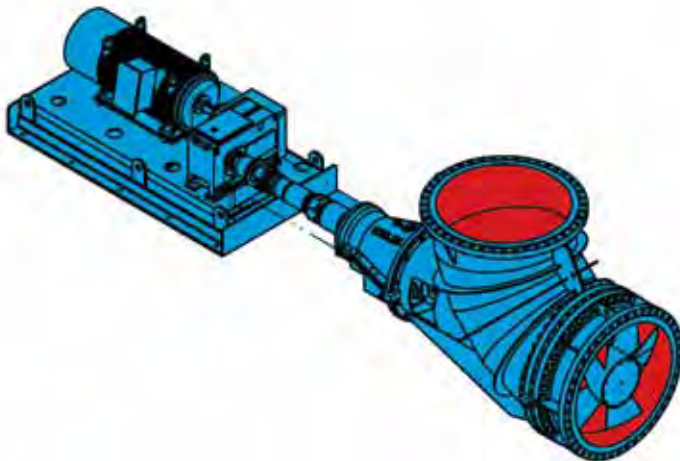

Pipe Hung

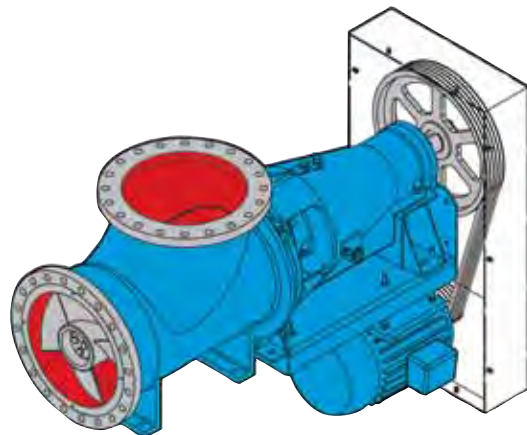

Under Slung

Hydraulic Coverage

Hydraulic Coverage

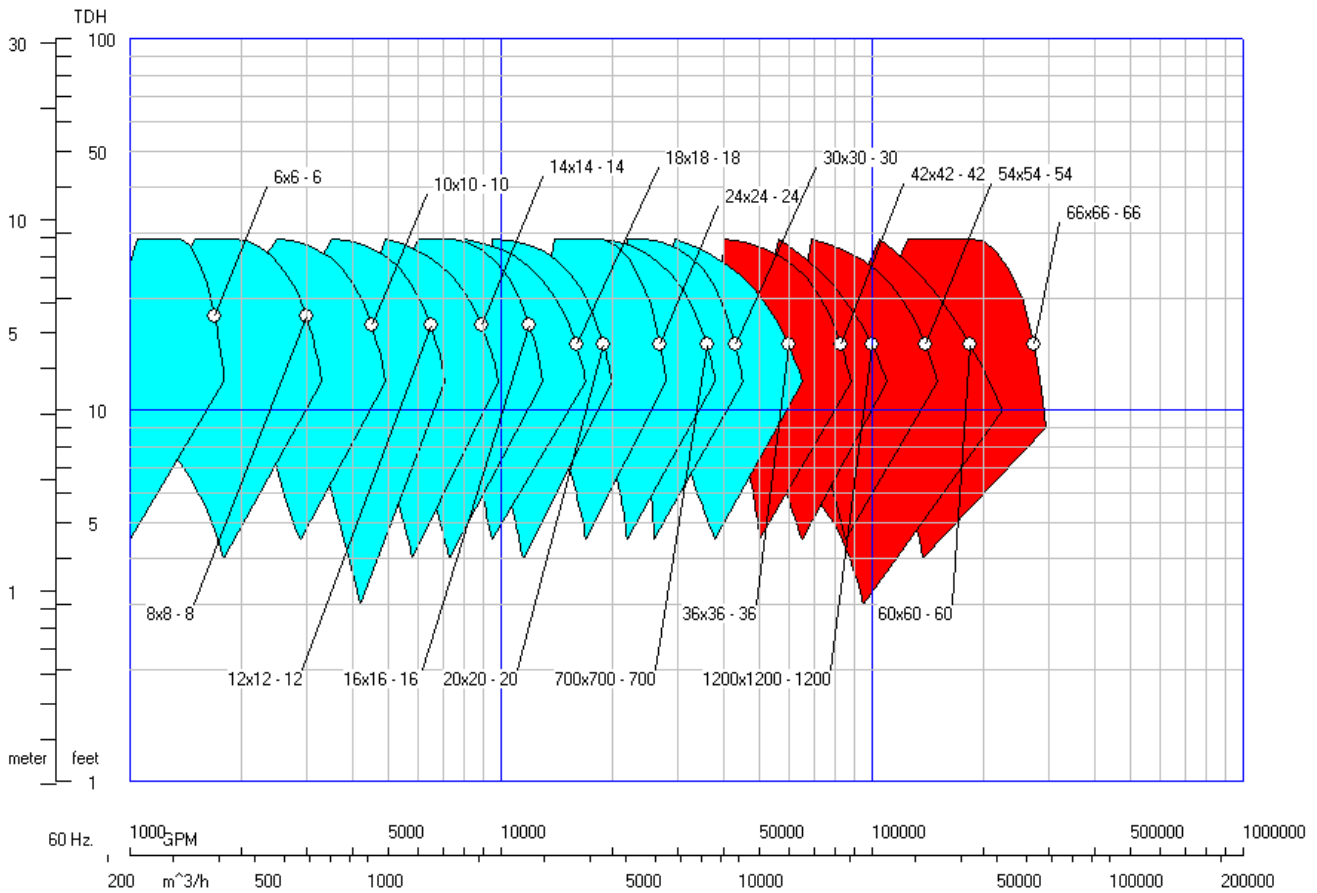

Visit our website at
www.gouldspumps.com

Wherever you are, we're there too.

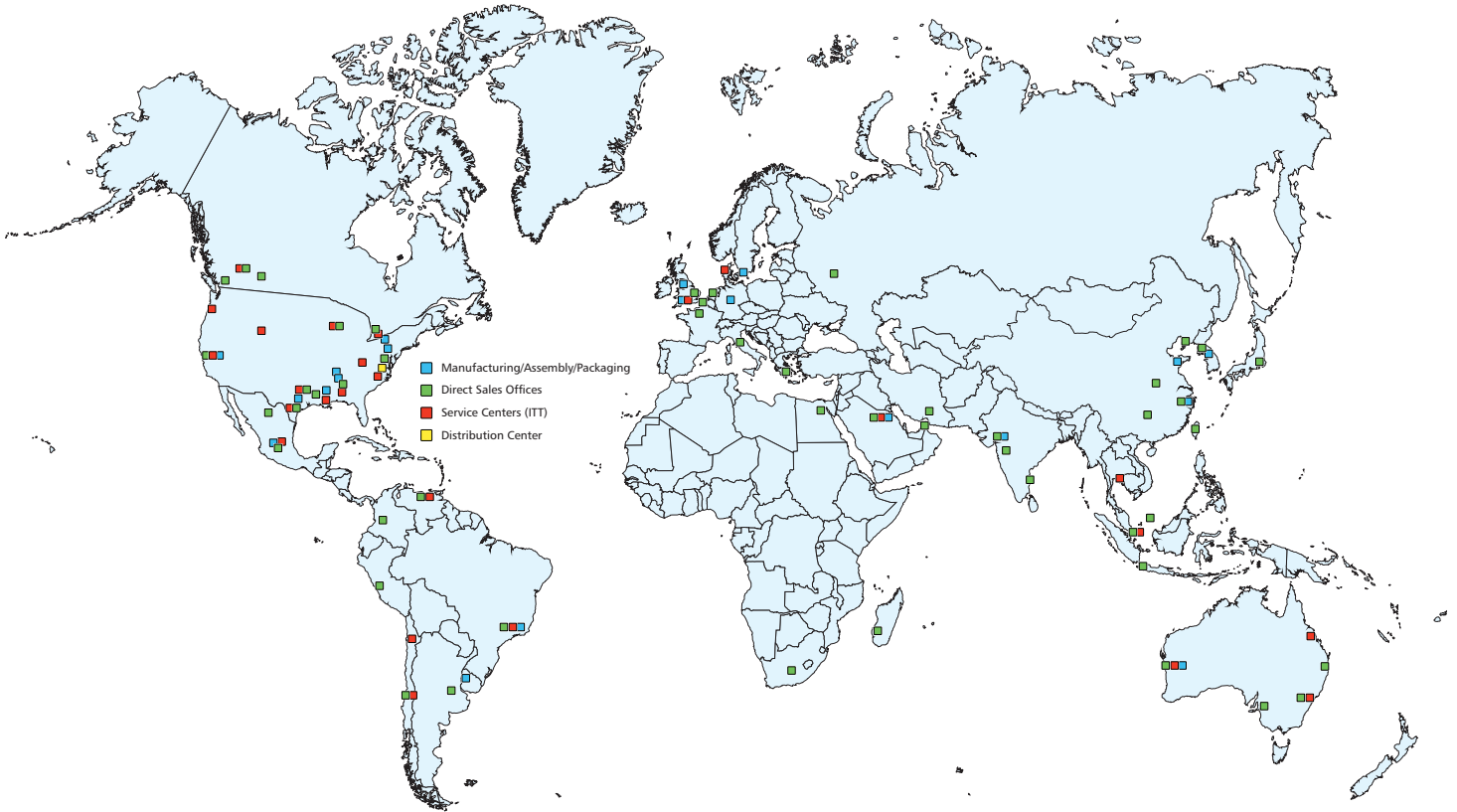

Reliability has no quitting time.

Building on over 160 years of Goulds Pumps experience, PRO Services provides an array of services focused on reducing equipment total cost of ownership (TCO) and increasing plant output, including predictive monitoring, maintenance contracts, field service, engineered upgrades, inventory management, and overhauls for pumps and other rotating equipment.

Your Total Solution For Equipment Life Cycle Optimization

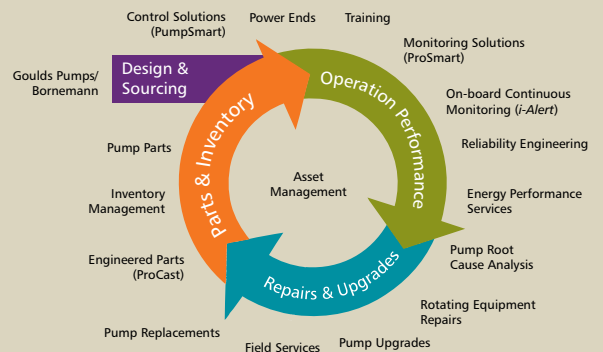

Form BAF 11/14



240 Fall Street
 Seneca Falls, NY 13148
www.itt.com

AUSTRALIAN DISTRIBUTOR



CALL 1300 789 466

When Pump Knowledge Matters
www.kelairpumps.com.au