

Schraubenspindelpumpe
Baureihe M
Screw pump series M

40 bar

KRAL

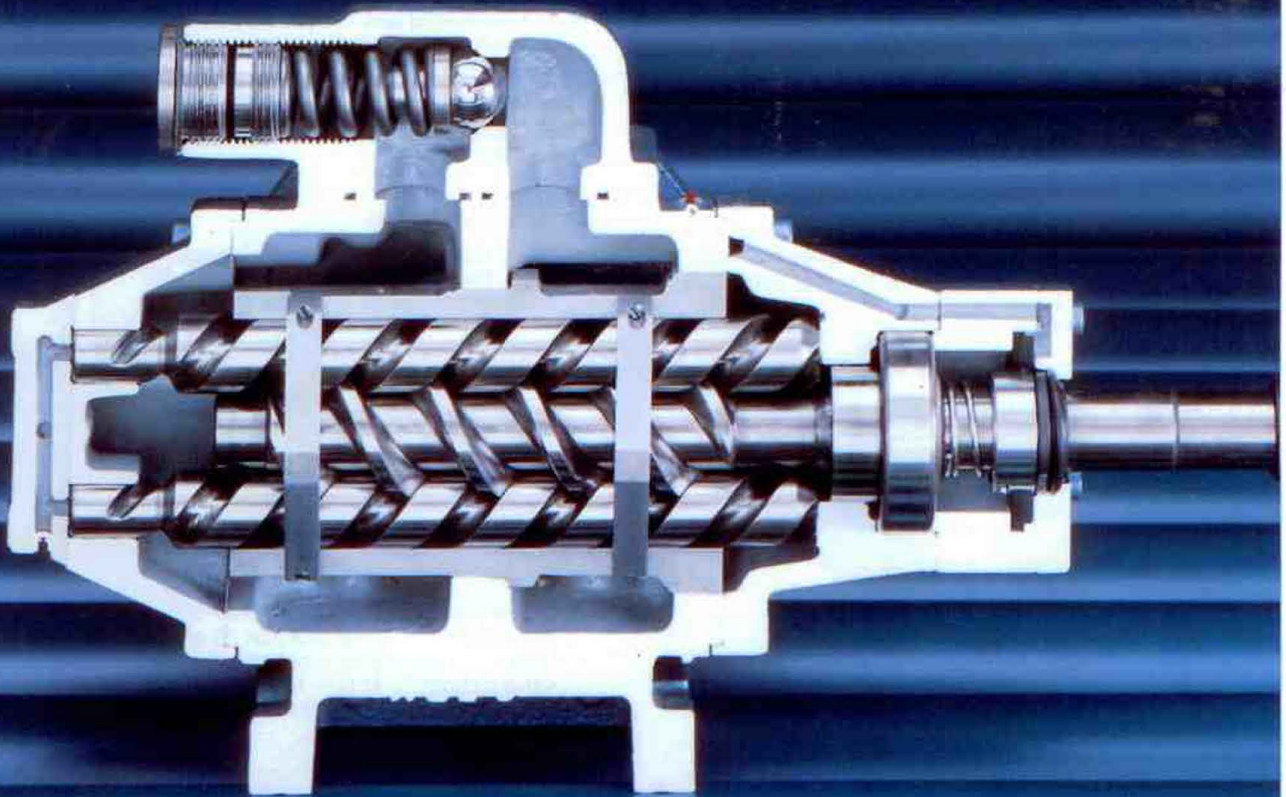

Anwendungsbereich

KRAL-Schraubenspindelpumpen werden verwendet zum Fördern von Schmierölen, Heizölen und anderen schmierenden Flüssigkeiten.

Haupt Einsatzgebiete sind alle Industriebereiche z. B. als Brennerpumpen in der Ölfeuerungstechnik, Abfüllpumpen in Tankanlagen, Schmierölpumpen in der Schiffsindustrie, Hydraulik- und Maschinenbauindustrie.

Wirkungsweise

KRAL-Schraubenspindelpumpen sind selbstansaugende Verdrängerpumpen. Durch besondere Profilgebung der drei sich drehenden Spindeln werden abgedichtete Kammern gebildet. Mittels diesem Prinzip fördern die Pumpen kontinuierlich ohne Quetschung und Turbulenz durch Rotation von der Saugseite zur Druckseite.

Technische Daten

Dreh Sinn: rechts vom Antrieb gesehen (Linksläufer auf Anfrage)
 Fördermenge: 3 – 420 l/min
 Betriebsdruck: max. 40 bar
 Zulaufdruck: bis 7 bar (Sonderausführung bis 30 bar)
 Temperatur: max. 180 °C
 Viskosität: max. 7000 mm²/s
 Höhere Werte auf Anfrage

Typenschlüssel

	M	F	U	G	85
1) Typenreihe	M				
2) Bauform		F			
* Flanschausführung		H			
* Fußausführung		V			
* Sockelausführung		U			
3) Sicherheitsventil			U		
Rücklauf			T		
4) Wellendichtung				G	
* Gleitringdichtung				P	
* Packung				R	
* Radialdichtringe					
5) Sonstiges					A
* Sonderausführung Außenlager					
6) Baugröße					

Sicherheitsventil

KRAL-Schraubenspindelpumpen können wahlweise mit oder ohne Sicherheitsventil geliefert werden. Das Ventil dient zum Schutz der Pumpe vor Überlastung und darf nicht als Steuer- und Regelventil eingesetzt werden.

Beheizung

KRAL-Schraubenspindelpumpen können mit einer Dampfheizschale oder elektrischer Heizung ausgerüstet werden.

Werkstoffe

Förderspindeln: Stahl nitriert
 Laufgehäuse: Silafont, M 15 – M 42 oder GGG 40
 Außengehäuse: M 55 – M 210 oder GGG 40
 Flanschdeckel: GG 20 oder GGG 40
 Abschlußdeckel: GG 20 oder GGG 40
 Sockel: GG 20 oder GGG 40
 Ventilgehäuse: M 55 – M 210 oder GGG 40

Ausschreibungstext

... Stück KRAL 3-spindelige Schraubenspindelpumpen mit oder ohne Sicherheitsventil.

Type
 in Fuß-/Flansch-/Sockelausführung
 für horizontale/vertikale Anordnung
 mit Kupplung/Kupplungsschutz
 Fußlaterne/Flanschlaterne
 Grundplatte
 Drehstrommotor 50 Hz/60 Hz

Application

KRAL screw pumps are applied to deliver lubricating oil, fuel oil and other lubricating fluids.

Main areas of application are all ranges of industry e.g. pumps in the oil burning industry, transfer pumps in the loading and unloading service, lubricating pumps in the marine industry, hydraulic, machinery and fuel oil service.

Principle of operation

KRAL screw pumps are self priming positive displacement pumps. Through the special profile of the three screws, sealed chambers are being built. By means of the principle the pumps deliver continuously, without violent pressure and turbulence, through rotation from suction side to pressure side.

Technical data

rotation: clockwise from coupling end (anti-clockwise on request)
 capacity: 3 – 420 l/min
 pressure: max. 40 bar
 suction pressure: up to 7 bar (special design up to 30 bar)
 operating temperature: max. 180 °C
 viscosity: max. 7000 mm²/s
 higher values on request

Type key

	M	F	U	G	85
1) series K	M				
2) structural shape		F			
* flange design		H			
* foot design		V			
* vertical design		U			
3) safety valve			U		
by pass			T		
return pass					
4) shaft seal				G	
* mechanical seal				P	
* stuff packing				R	
* radial shaft seal					
5) others					A
* special design outside bearing					
6) size					

Safety valve

KRAL screw pumps can be supplied either with or without safety valve. The valve protects the pump against overpressure and must not be used as a control valve.

Heating device

KRAL screw pumps can be equipped with a steam heating device or an electrical heating device.

Materials

screws: steel nitrated
 casing: Silafont, M 15 – M 42 or nodular graphite cast iron 40
 outside casing: M 55 – M 210
 or nodular graphite cast iron 40
 flange cover: gray cast iron 20 or nodular graphite cast iron 40
 end cover: gray cast iron 20 or nodular graphite cast iron 40
 base: gray cast iron 20 or nodular graphite cast iron 40
 valve casing: M 55 – M 210
 or nodular graphite cast iron 40

Bid text

... pc(s) KRAL 3-spindle screw pumps with/without safety valve.

type
 in foot-/flange-/base-design
 for horizontal/vertical lay out
 with coupling/coupling protection
 foot lantern/flange lantern
 base plate
 three phase A.C. motor 50 Hz/60 Hz

Flanschpumpe MF

Pumpenaggregat bestehend aus Pumpe, Kupplung, Fußlaterne und Motor

flange pump MF

Pump aggregate consisting of pump, coupling, foot lantern, el. motor



Fußpumpe MH

Pumpenaggregat bestehend aus Pumpe, Kupplung, Motor, Kupplungsschutz und Grundrahmen

foot pump MH

Pump aggregate consisting of pump, coupling, el. motor, coupling protection and base frame

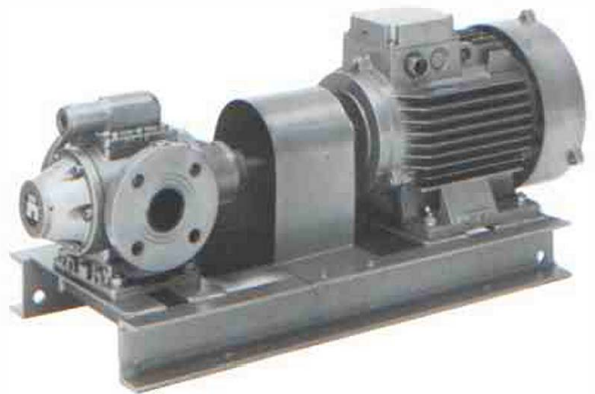

Einzelstation

Type EM

komplett mit Einzelaggregat, Filter und Absperrarmaturen auf Ölwanne zusammengebaut (spezielle Unterlagen erhältlich)

single station

type EM

complete with single aggregate, filter and valves mounted onto oilpan (specific documentation available)



Doppelstation

Type DM

komplett mit 2 Einzelaggregaten, Filter und Absperrarmaturen auf Ölwanne zusammengebaut (spezielle Unterlagen erhältlich)

double station

type DM

complete with 2 single aggregates, filter and valves mounted onto oilpan (specific documentation available)

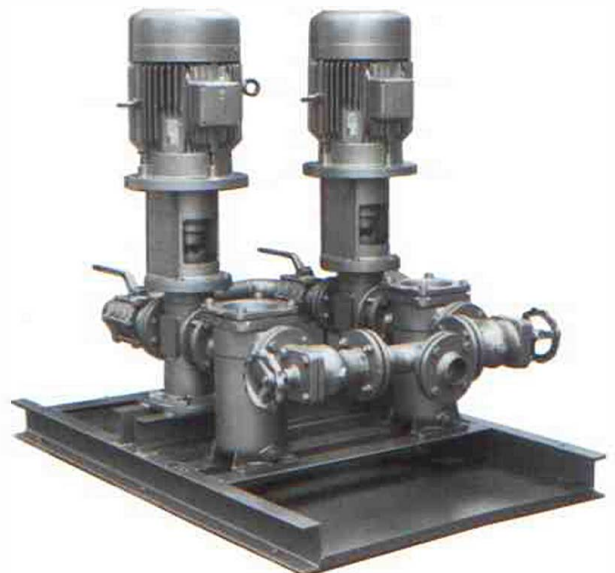

Schnittbild section drawing

Type M 5 – M 10

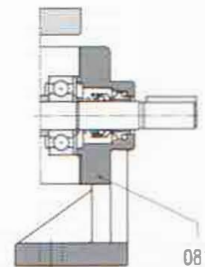
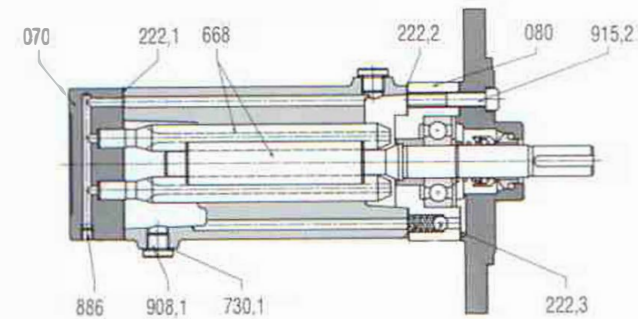
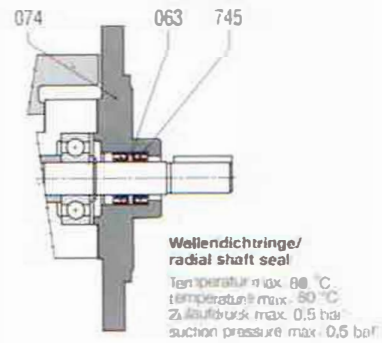
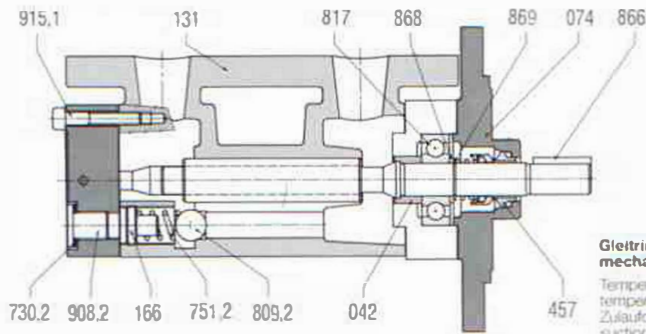

Type M 15 – M 42

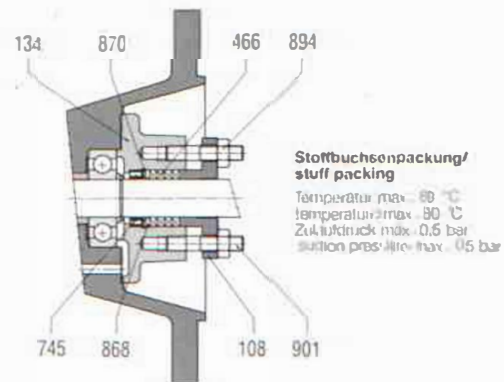
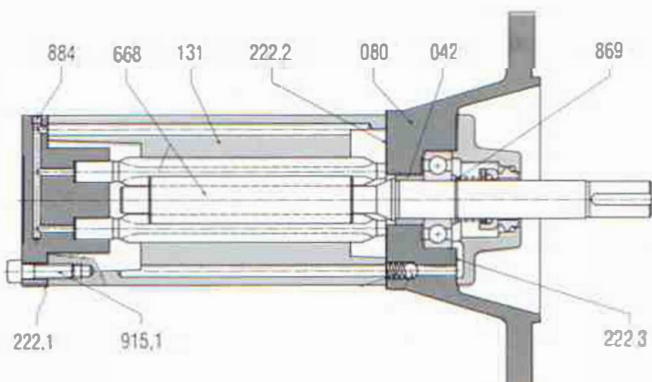
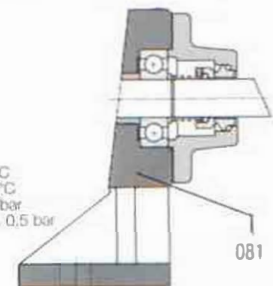
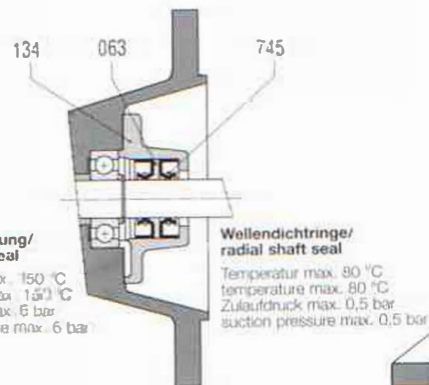
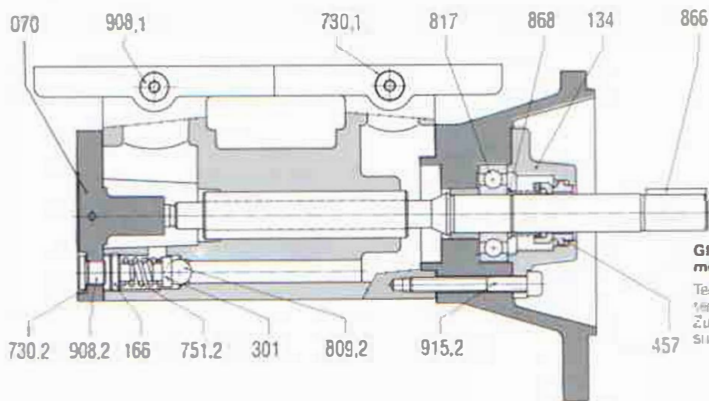

Außenlagerung outside bearing Type M 15 – M 42

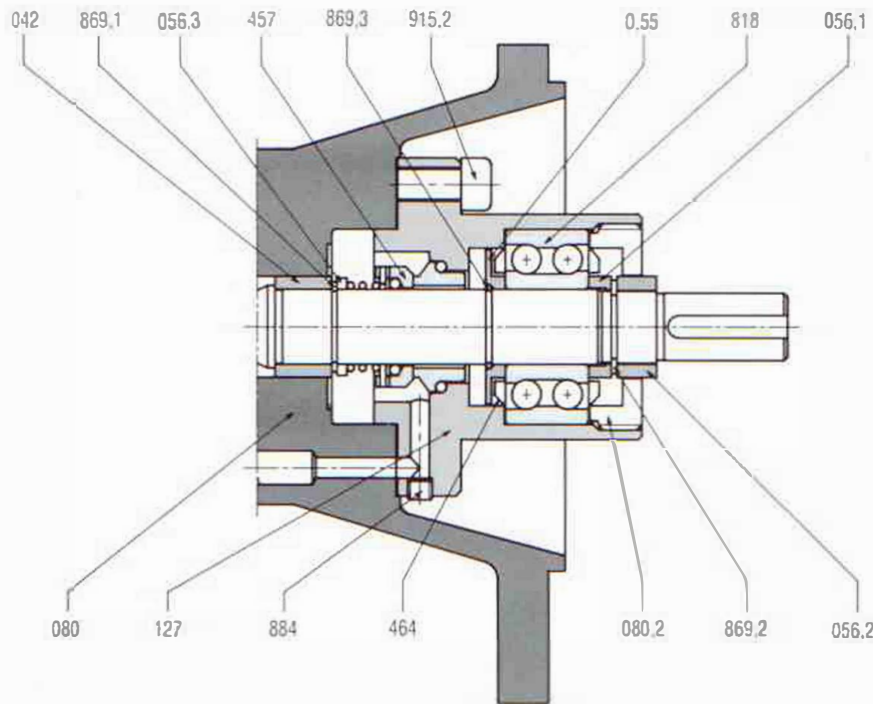

* 042 Ausgleichshülse	730,1 Flachdichtung	* 042 balance sleeve	730,1 gasket
055 Distanzring	730,2 Flachdichtung	055 spacer ring	730,2 gasket
056,1 Distanzring	* 745 Radialdichtring	056,1 spacer ring	* 745 radial shaft seal
056,2 Distanzring		056,2 spacer ring	* 751,2 spring
056,3 Distanzring	* 751,2 Druckfeder	058,3 spacer ring	* 809,2 ball
* 063 Stützring		* 063 spacer	* 817 ball bearing
070 Abschlußdeckel	* 809,2 Kugel	070 end cover	* 818 angular ball bearing
074 Flanschdeckel	* 817 Kugellager	074 flange cover	866 key
080 Lagerdeckel	* 818 Schrägkugellager	080 bearing cover	868 spacer
080,2 Lagerdeckel	866 Paßfeder	080,2 bearing cover	* 869 circlip
081 Lagerdeckel mit Fuß	868 Stützring	081 bearing cover with foot	* 869,1 circlip
108 Stopfbuchsflansch	* 869 Wellensicherungsring	108 stuffing box flange	* 869,2 circlip
127 Lagergehäuse	* 869,1 Wellensicherungsring	127 bearing housing	* 869,3 circlip
* 131 Gehäuse	* 869,2 Wellensicherungsring	* 131 casing	* 870 circlip
134 Dichtungsgehäuse	* 869,3 Runddrahtsprengring	134 seal case	884 set screw
166 Verstellerschraube	* 870 Wellensicherungsring	166 adjusting screw	886 set screw
* 222,1 Dichtung	884 Gewindestift	* 222,1 gasket	894 hexagon nut
* 222,2 Dichtung	886 Gewindestift	* 222,2 gasket	901 locking screw
* 222,3 Dichtung	894 Sechskantmutter	* 222,3 gasket	908,1 head bolt
301 Federteller	901 Stiftschraube	301 spring support	908,2 head bolt
* 457 Gleitringdichtung	908,1 Verschußschraube	* 457 mechanical seal	915,1 socket screw
464 Nilos Ring	908,2 Verschußschraube	464 Nilos ring	915,2 socket screw
* 466 Packungsring	915,1 Zylinderschraube	* 466 packing ring	
* 668 Spindelsatz	915,2 Zylinderschraube	* 668 spindle set	

*empfohlene Ersatzteile

*recommended spare parts

Schnittbild section drawing

Type M 55 – M 210

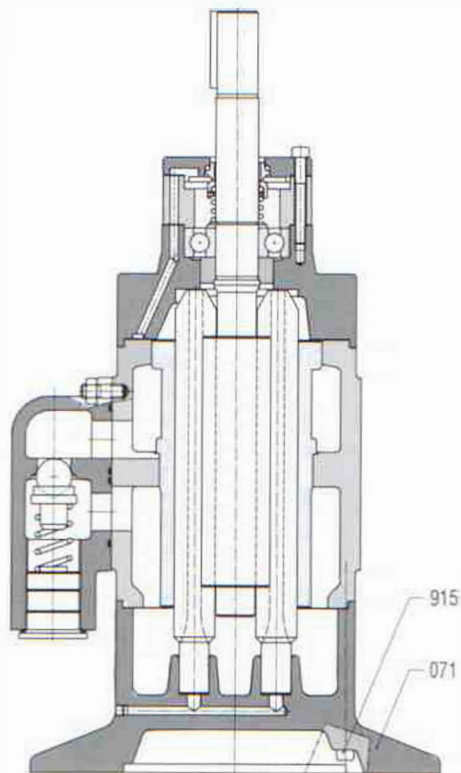
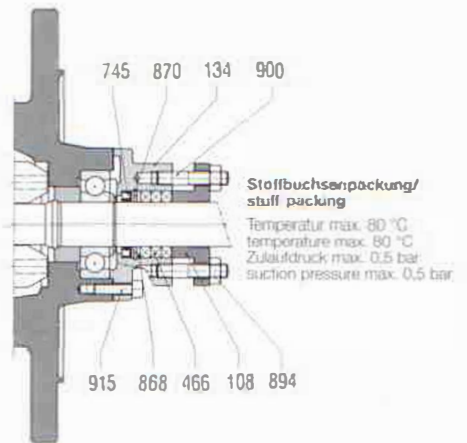
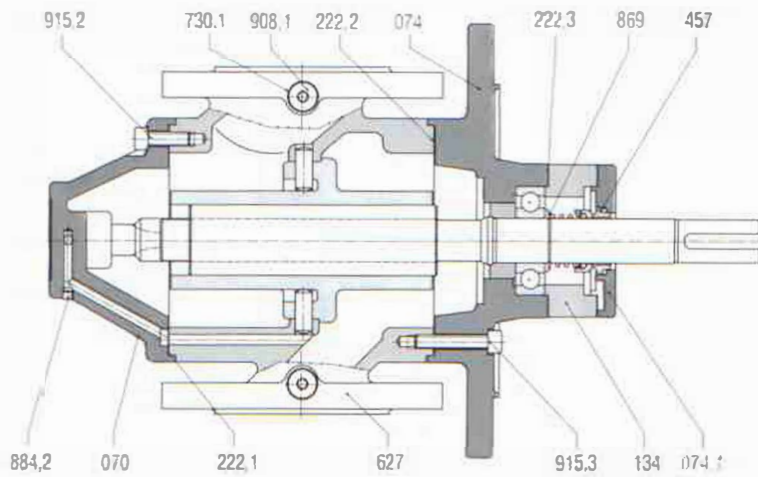
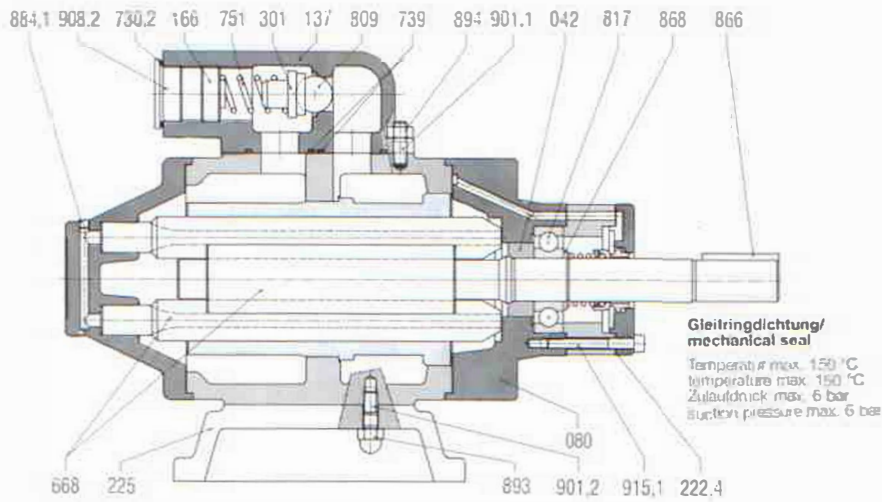

Außenlagerung outside bearing

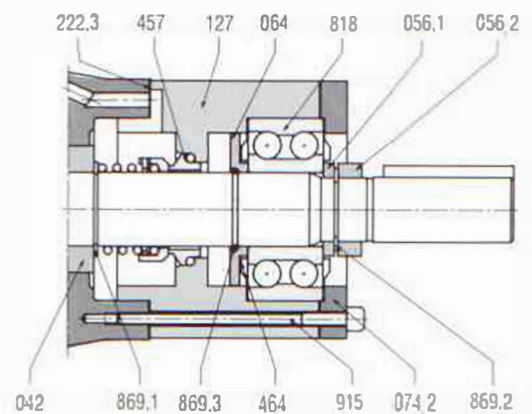

- * 042 Ausgleichshülse
- 056,1 Distanzring
- 056,2 Distanzring
- * 063 Stützring
- 064 Dichtungsscheibe
- 070 Abschlußdeckel
- 071 Abschlußdeckel mit Fuß
- 074 Flanschdeckel
- 074,1 Flanschdeckel
- 074,2 Flanschdeckel
- 080 Lagerdeckel
- 108 Stopfbuchsflansch
- 127 Lagergehäuse
- 134 Dichtungsgehäuse
- 137 Ventilgehäuse
- 166 Verstellerschraube
- * 222,1 Dichtung
- * 222,2 Dichtung
- * 222,3 Dichtung
- * 222,4 Dichtung
- 225 Pumpenfuß
- 301 Federteller
- * 457 Gleitringdichtung
- * 466 Packungsring
- * 627 Gehäuse
- * 688 Spindelsatz
- 730,1 Flachdichtung
- 730,2 Flachdichtung
- 464 Nilos Ring
- * 739 O-Ring
- * 745 Radialdichtring
- * 751 Druckfeder
- * 809 Kugel
- * 817 Kugellager
- * 818 Schrägkugellager
- 866 Paßfeder
- 868 Stützring
- * 869 Wellensicherungsring
- * 869,1 Wellensicherungsring
- * 869,2 Wellensicherungsring
- * 869,3 Wellensicherungsring
- * 870 Wellensicherungsring
- 884,1 Gewindestift
- 884,2 Gewindestift
- 893 Hutmutter
- 894 Sechskantmutter
- 900 Stiftschraube
- 901,1 Stiftschraube
- 901,2 Stiftschraube
- 908,1 Verschlussschraube
- 908,2 Verschlussschraube
- 915 Zylinderschraube
- 915,1 Zylinderschraube
- 915,2 Zylinderschraube
- 915,3 Zylinderschraube

- * 042 balance sleeve
- 056,1 spacer ring
- 056,2 spacer ring
- * 063 support plate
- 064 seal disc
- 070 endcover
- 071 endcover with foot
- 074 flange cover
- 074,1 flange cover
- 074,2 flange cover
- 080 bearing cover
- 108 stuffing box flange
- 127 bearing housing
- 134 seal casing
- 137 valve casing
- 166 adjusting screw
- * 222,1 gasket
- * 222,2 gasket
- * 222,3 gasket
- * 222,4 gasket
- 225 pump foot
- 301 spring support
- * 457 mechanical seal
- * 466 packing ring
- * 627 casing
- * 688 spindle set
- 730,1 gasket
- 730,2 gasket
- 464 Nilos ring
- * 739 O-ring
- * 745 radial shaft seal
- * 751 spring
- * 809 ball
- * 817 ball bearing
- * 818 angular ball bearing
- 866 key
- 868 spacer
- * 869 circlip
- * 869,1 circlip
- * 869,2 circlip
- * 869,3 circlip
- * 870 circlip
- 884,1 set screw
- 884,2 set screw
- 893 cap nut
- 894 hexagon nut
- 900 locking screw
- 901,1 locking screw
- 901,2 locking screw
- 908,1 head bolt
- 908,2 head bolt
- 915 socket screw
- 915,1 socket screw
- 915,2 socket screw
- 915,3 socket screw

Flanschausführung MF

flange mounted design MF

Type MF 5 – MF 42

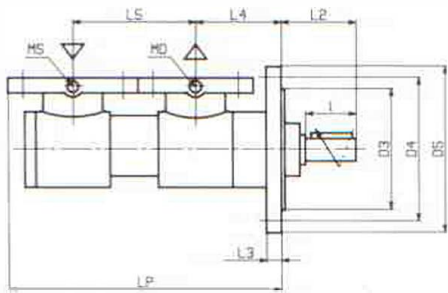

Saugflansch
Nenndruck PN 6
suction flange
nominal pressure PN 6

Druckflansch
Nenndruck PN 40
pressure flange
nominal pressure PN 40

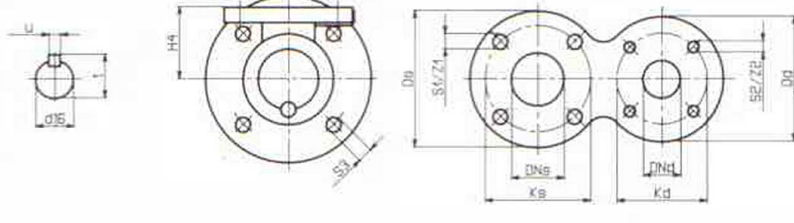

Type MF 55 – MF 210

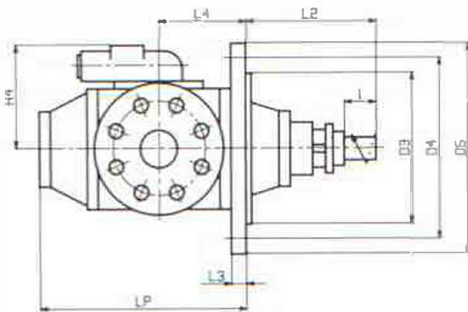

Saugflansch
Nenndruck PN 10
suction flange
nominal pressure PN 10

Druckflansch
Nenndruck PN 40
pressure flange
nominal pressure PN 40

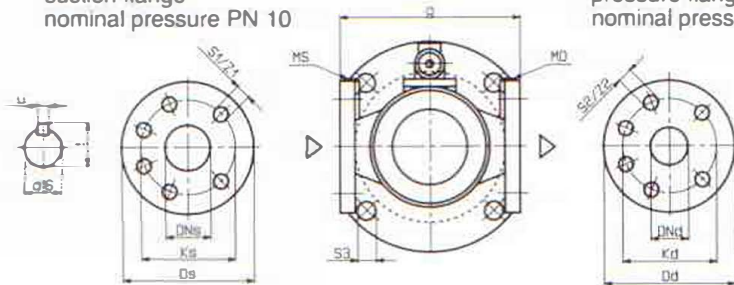

Aggregat MF 5 – MF 42

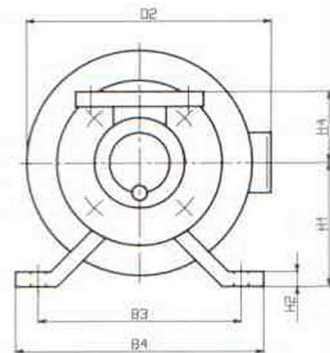
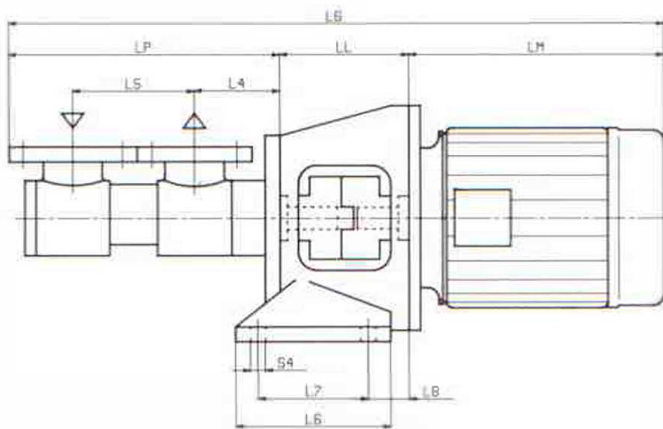

Aggregat MF 55 – MF 210

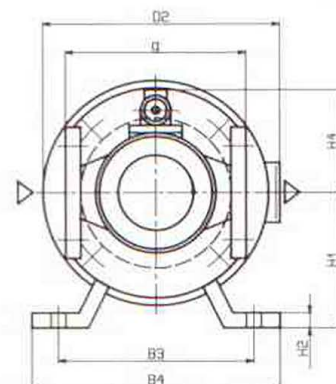
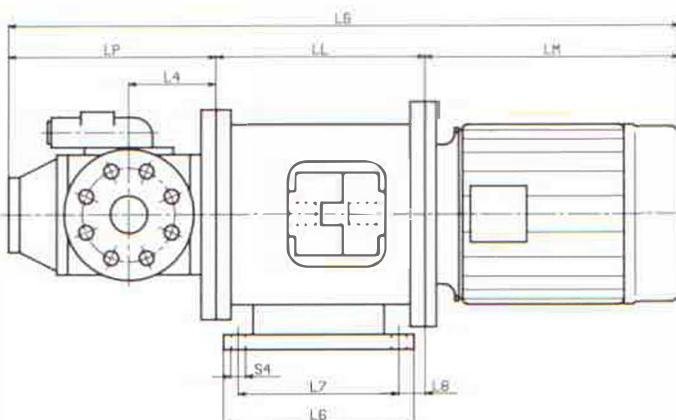

Fußausführung MH foot mounted design MH

Type MH 5 – MH 42

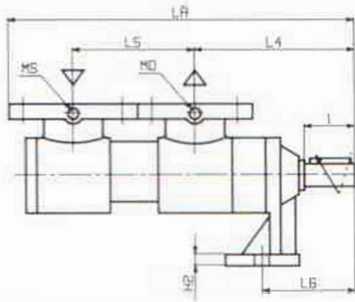

Saugflansch
Nenndruck PN 6
suction flange
nominal pressure PN 6

Druckflansch
Nenndruck PN 40
pressure flange
nominal pressure PN 40

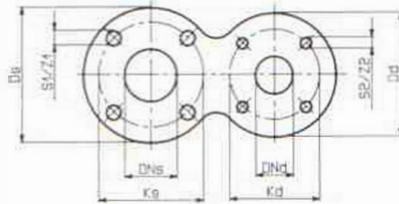

Type MH 55 – MH 210

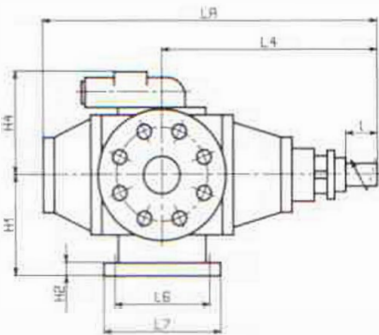

Saugflansch
Nenndruck PN 10
suction flange
nominal pressure PN 10

Druckflansch
Nenndruck PN 40
pressure flange
nominal pressure PN 40

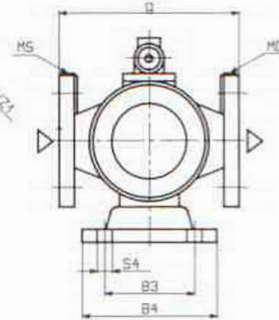
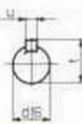

Aggregat MH 5 – MH 42

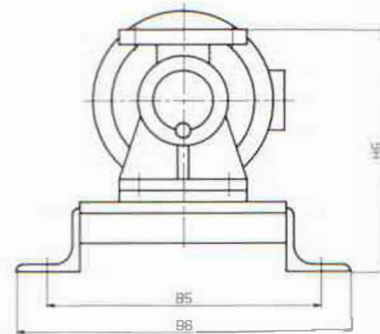
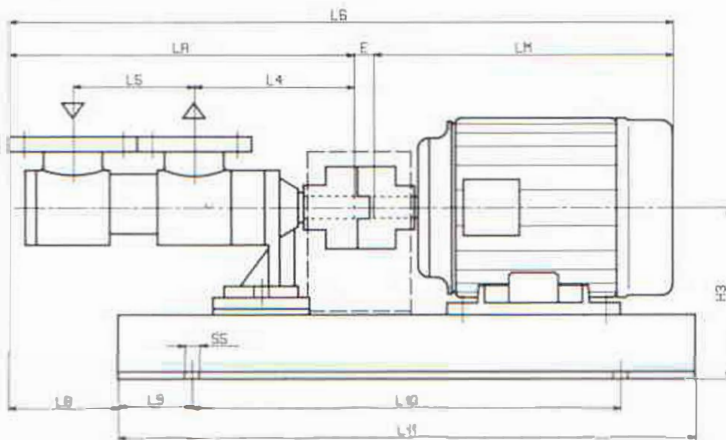

Aggregat MH 55 – MH 210

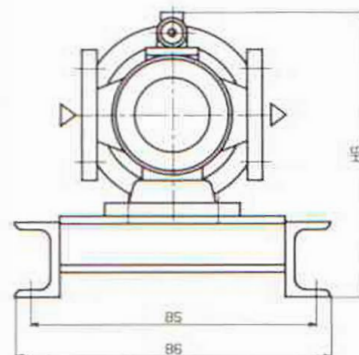
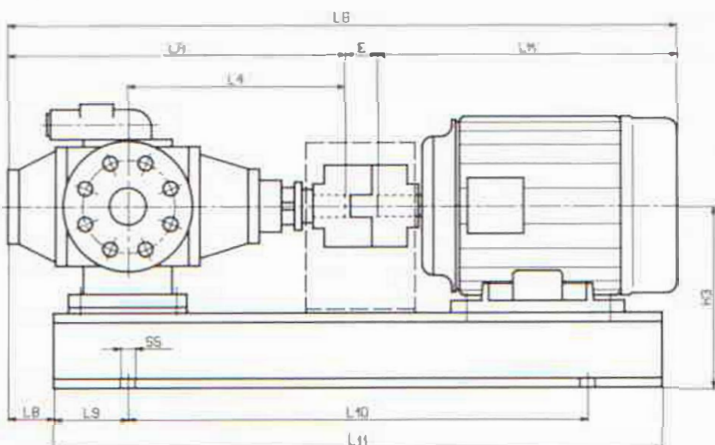

Pumpe pump	Motor motor	Flanschen flanges											Pumpenmaße pump dimensions				Fu8 foot				Wellenende shaft end				Aggregat aggregate														
		DNs	Ds	Ks	DNd	Dd	Kd	S1	Z1	S2	Z2	g	L4	L5	LA	H4	L6	L7	H1	H2	B3	B4	S4	d	l	f	v	L8	L9	L10	L11	E	LM	LG	B5	B6	H3	HG	S5
5 7.5 10	71																										100	75	300	450	10	231	486	240	300	150	210	12	
	80	20	90	65	15	90	65	11	4	14	4	-	107	91.5	245	60	75	-	80	12	60	100	12	14	30	16	5	100	75	300	450	11	267	523	240	300	150	210	12
	90 S																											100	75	300	450	20	294	559	240	300	160	220	12
	90 L																											100	75	300	450	20	319	584	240	300	160	220	12
15 20 26	80																										110	75	450	600	31	267	658	290	350	170	250	14	
	90 S																										110	75	450	600	28	294	682	290	350	170	250	14	
	90 L																										110	75	450	600	28	319	707	290	350	170	250	14	
	100 L	40	130	100	25	120	85	14	4	14	4	-	170	127	360	80	155	-	100	12	88	140	14	19	35	21	6	110	75	450	600	13	363	736	290	350	170	250	14
	112 M																											110	75	450	600	13	380	753	290	350	182	262	14
	132 S																											145	75	480	630	20	442	822	310	350	227	307	14
32 42	80																										130	75	450	600	16	267	673	290	350	170	250	14	
	90 S																										130	75	450	600	8	294	692	290	350	170	250	14	
	90 L																										130	75	450	600	8	319	717	290	350	170	250	14	
	100 L	40	130	100	25	120	85	14	4	14	4	-	180	127	390	80	165	-	100	12	98	140	14	19	40	21	6	130	75	450	600	13	363	766	290	350	170	250	14
	112 M																											130	75	450	600	13	380	783	290	350	182	262	14
	132 S																											165	75	480	630	10	442	842	310	350	227	307	14
	132 M																											165	75	480	630	10	480	880	310	350	227	307	14
55 74 85	90 L																										63	100	450	650	5	319	744	290	330	197	331	18	
	100 L																										63	100	450	650	19	363	802	290	330	197	331	18	
	112 M	50	165	125	50	165	125	18	4	18	4	200	260	-	420	134	110	140	112	10	140	170	14	24	50	27	8	63	100	450	650	19	380	819	290	330	197	331	18
	132 S																										66	150	450	750	5	442	867	315	355	197	331	18	
	132 M																										66	150	450	750	5	480	905	315	355	197	331	18	
	160 M																										60	105	730	930	19	583	1022	250	330	290	424	20	
105 118	100 L																										88	150	450	750	9	363	862	315	355	197	331	18	
	112 M																										88	150	450	750	9	380	879	315	355	197	331	18	
	132 S	65	185	145	65	185	145	18	4	18	8	220	315	-	490	134	110	140	112	10	140	170	14	28	60	31	8	60	150	550	850	16	442	948	315	355	197	331	18
	132 M																										60	150	550	850	16	480	986	315	355	197	331	18	
	160 M																										90	105	730	930	9	583	1082	250	330	290	424	20	
	160 L																										90	105	730	930	9	627	1126	250	330	290	424	20	
	180 M																										60	155	700	990	16	650	1156	280	380	310	444	20	
	200 M																										105	150	510	810	9	380	969	315	355	217	359	18	
160 210	112 M																										105	150	550	850	16	442	1038	315	355	217	359	18	
	132 S																										105	150	550	850	16	480	1076	315	355	217	359	18	
	132 M																										105	150	550	850	16	480	1076	315	355	217	359	18	
	160 M	80	200	160	80	200	160	18	8	18	8	330	360	-	580	142	140	180	132	12	175	200	14	28	60	31	8	115	155	730	1030	9	583	1172	265	375	290	432	20
	160 L																										115	155	730	1030	9	627	1216	265	375	290	432	20	
	180 M																										115	155	730	1030	16	650	1246	265	375	312	432	20	
	200																										110	180	800	1150	16	738	1334	320	410	330	472	20	
	225 M																										115	205	850	1200	16	825	1421	360	470	357	499	20	

MS ... Vakuummeteranschluß
Größe M 5 – M 42: R 1/8"
Größe M 55 – M 210: R 1/4"

MD ... Manometeranschluß
Größe M 5 – M 42: R 1/8"
Größe M 55 – M 210: R 1/4"

MS ... Vacuummeter connection
size M 5 – M 42: R 1/8"
size M 55 – M 210: R 1/4"

MD ... Manometer connection
size M 5 – M 42: R 1/8"
size M 55 – M 210: R 1/4"

Sockelausführung MV vertical design MV

Type MV 55 – MV 210

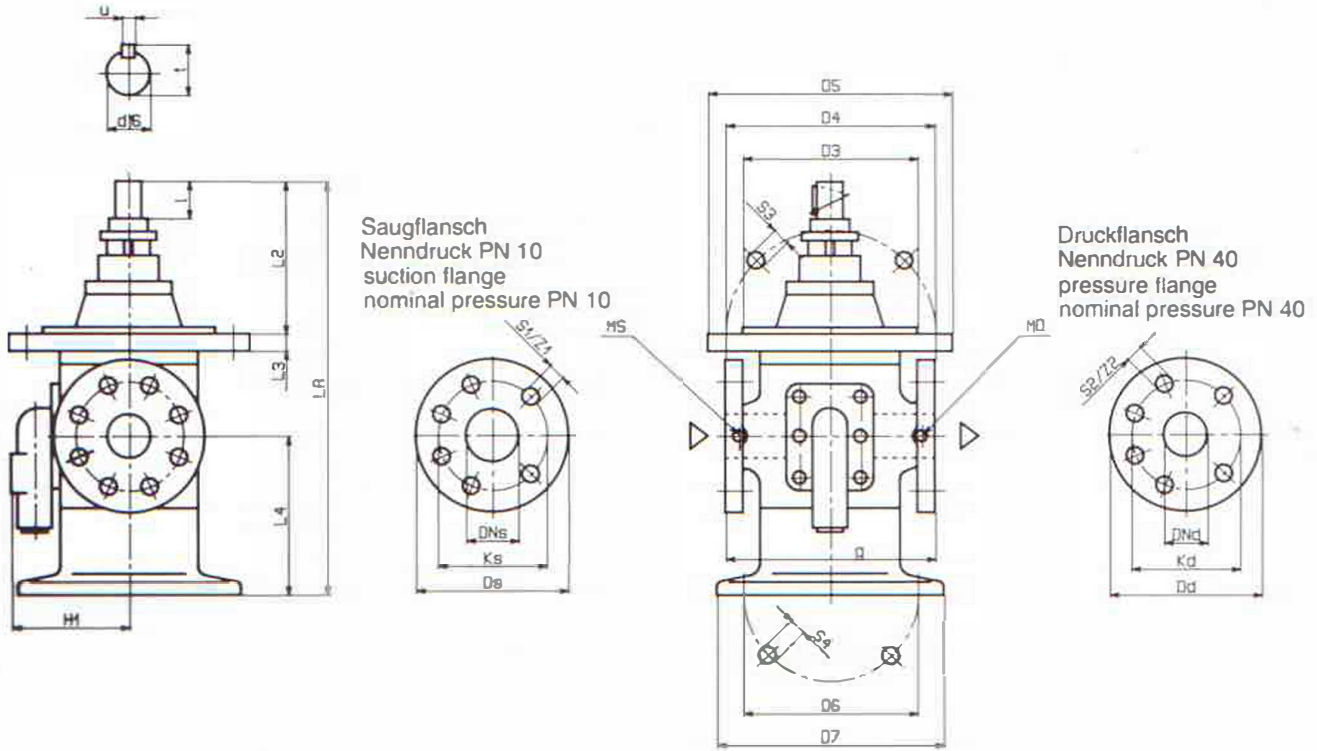

Aggregat MV 55 – MV 210

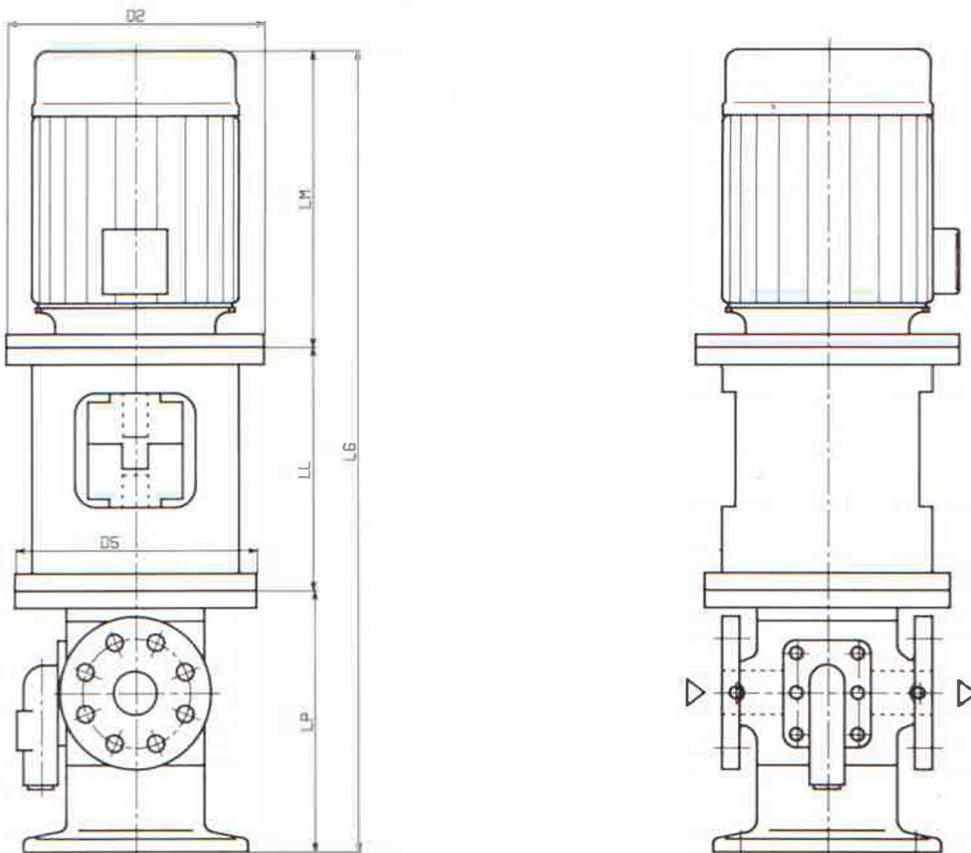

Pumpe pump	Motor motor	Flanschen flanges											Pumpenmaße pump dimensions											Wellenende shaft end				Aggregat aggregate					Sockel base			
		DNs	Ds	Ks	DNd	Dd	Kd	S1	Z1	S2	Z2	g	D3	D4	D5	S3	L2	L3	L4	LA	H1	d	l	t	v	LM	LL	LP	LG	D2	D6	D7	S4			
55 74 85	90 L																								270	210	275	755	200							
	100 L																								300	230	275	805	250							
	112 M	50	165	125	50	165	125	18	4	18	4	200	180	215	250	14	155	15	170	430	134	24	50	27	8	320	230	275	825	250	190	240	18			
	132 S																								382	250	275	907	300							
	132 M																								420	250	275	945	300							
	160 M																								523	290	275	1088	350							
105 118	100 L																								300	230	335	865	250							
	112 M																								320	230	335	885	250							
	132 S	65	185	145	65	185	145	18	4	18	8	220	180	215	250	14	165	15	195	500	134	28	60	31	8	382	250	335	967	300	190	240	18			
	132 M																								420	250	335	1005	300							
	160 M																								523	290	335	1148	350							
	160 L																								567	290	335	1192	350							
160 210	180 M																								590	290	335	1215	350							
	112 M																								320	230	435	985	250							
	132 S																								382	250	435	1067	300							
	132 M	80	200	160	80	200	160	18	8	18	8	330	180	215	250	14	165	20	235	600	142	28	60	31	8	420	250	435	1105	300	245	300	24			
	160 M																								523	290	435	1248	350							
	160 L																								567	290	435	1292	350							
180 M																								590	290	435	1315	350								
200																								678	290	435	1403	400								

MS ... Vakuummeteranschluß
Größe M 55 – M 210; R 1/4"

MD ... Manometeranschluß
Größe M 55 – M 210; R 1/4"

MS ... Vacuummeter connection
size M 55 – M 210; R 1/4"

MD ... Manometer connection
size M 55 – M 210; R 1/4"

Heizung heating device

Elektro-Heizung electric heating device

Flanschpumpe flange pump

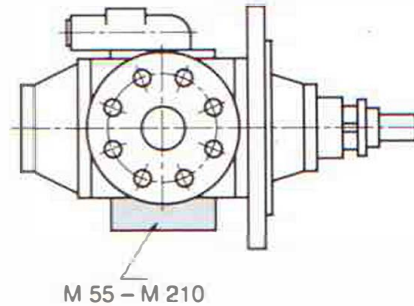
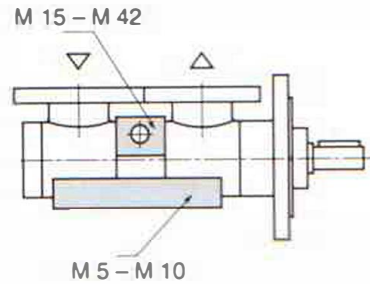

Fußpumpe foot pump

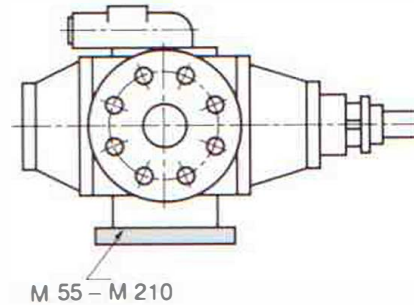
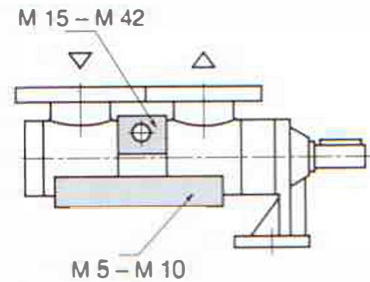

Heizungsleistung heating capacity

M 5 - M 42 100 Watt
M 55 - M 118 180 Watt
M 160 - M 210 250 Watt

Spannung 230 Volt
voltage 230 Volt

Frequenz 50 Hz
frequency 50 Hz

Leiterquerschnitt 2 x 1 mm²
wire cross section 2 x 1 mm²

MF 5 - MF 10
MH 5 - MH 10

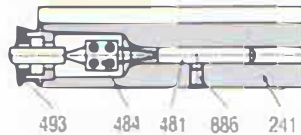

MF 15 - MF 42
MH 15 - MH 42

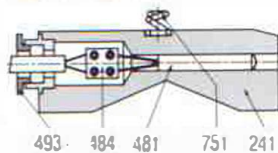

MF 55 - MF 210

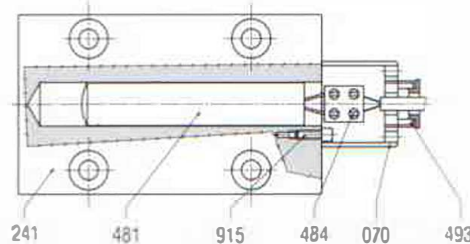

MH 55 - MH 210

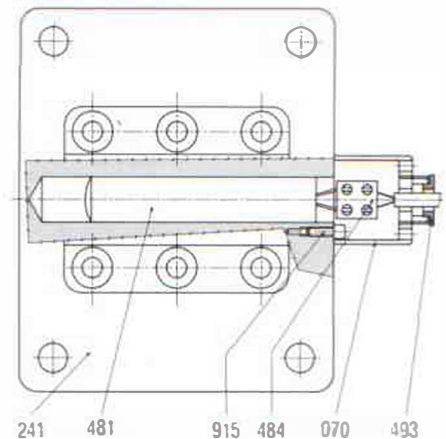

070 Abschlußdeckel
end cover
241 Heizwanne
heating tub
481 Heizpatrone
heating cartridge

484 Klemmleiste
porcelain terminal
493 Verschraubung
screw connection
751 Druckfeder
spring

886 Gewindestift
set screw
915 Zylinderschraube
socket screw

Medium Heizung medium-heating

Temperatur max. 180-220 °C
temperature max. 180-220 °C

Druck max. 18 bar
pressure max. 18 bar

Flanscpumpe flange pump

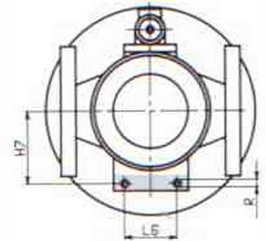
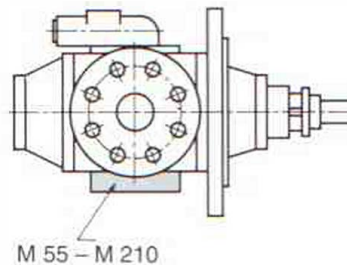
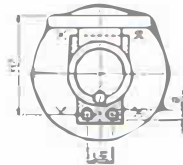
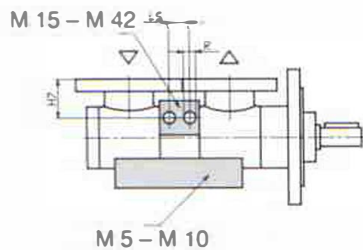

Fußpumpe foot pump

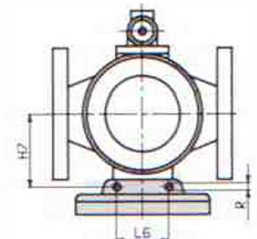
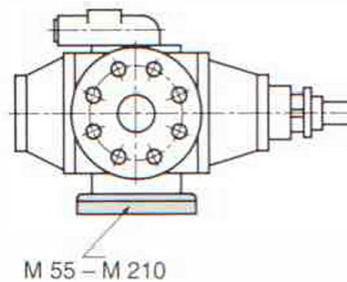
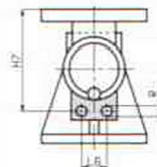
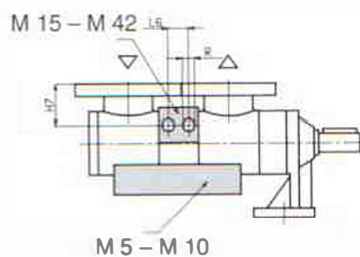

Anschlußmaße connecting dimensions

Baugröße/size	H7	L6	R	Baugröße/size	H7	L6	R
M 5 - M 10	112	30	3/8"	M 55 - M 118	90	70	1/4"
M 15 - M 42	32	25	3/8"	M 160 - M 210	118	90	1/4"

MF 5 - MF 10
MH 5 - MH 10

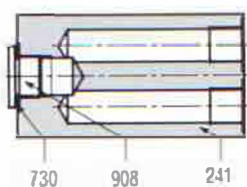

MF 15 - MF 42
MH 15 - MH 42

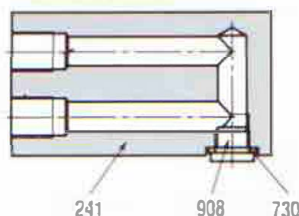

MF 55 - MF 210
MV 55 - MV 210

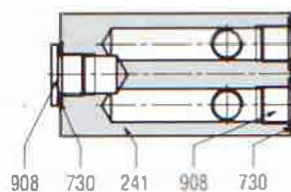

MH 55 - MH 210

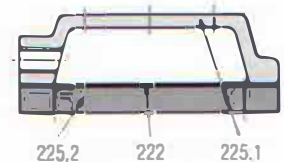

222 Dichtung
gasket
225,1 Pumpenfuß
pump foot

225.2 Heizplatte
heating plate
241 Heizwanne
heating tub

730 Flachdichtung
gasket
915 Verschlußschraube
head bolt

Sicherheitsventil

Safety valve

KRAL-Schraubenspindelpumpen können wahlweise mit oder ohne Sicherheitsventil geliefert werden. Das Ventil dient zum Schutz der Pumpe vor Überlastung und darf nicht als Steuer- und Regelventil eingesetzt werden.

KRAL screw pumps can be supplied either with or without safety valve. The valve protects the pump against overpressure and must not be used as a control valve.

Umlaufventil bypass valve

MF 5 – MF 42
MH 5 – MH 42

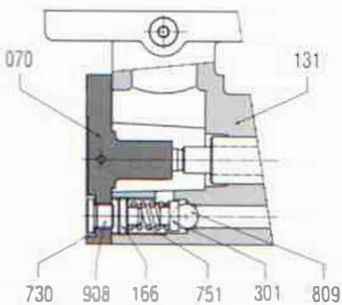

070 Abschlußdeckel
131 Pumpengehäuse
137 Ventilgehäuse
166 Verstellerschraube
301 Federteller
*304 Ventilkegel
*730 Flachdichtung
*739 O-Ring
*751 Druckfeder
*809 Ventilkugel
908 Verschlussschraube

Umlaufventil bypass valve

MF 55 – MF 210
MH 55 – MH 210
MV 55 – MV 210

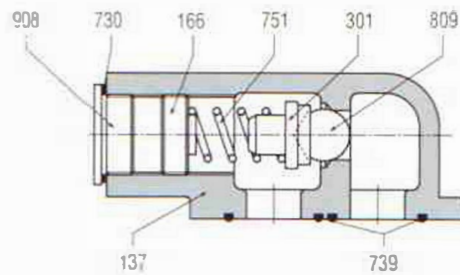

070 end cover
131 pump casing
137 valve casing
166 adjusting screw
301 spring
*304 valve cone
*730 flat gasket
*739 O-ring
*751 spring
*809 valve ball
908 head bolt

Rücklaufventil return pass valve

MF 55 – MF 210
MH 55 – MH 210
MV 55 – MV 210

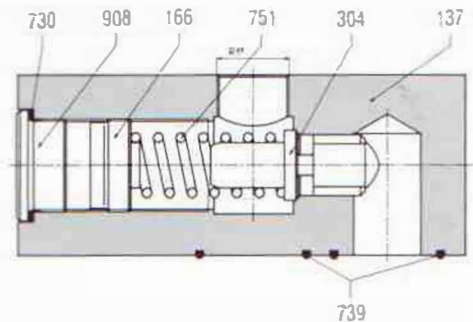

Einstellen des Ventiles:

Vor dem Verstellen muß die Verschlussschraube (908) entfernt werden. Jetzt ist die Verstellerschraube (166) frei zugänglich und kann mit einem Innensechskantschlüssel verdreht werden. Drehen nach rechts (im Uhrzeigersinn) erhöht, drehen nach links vermindert den Öffnungsdruck.

Der Öffnungsdruck wird ca. 10 – 20 % über dem Betriebsdruck eingestellt.

Operating instructions:

Before adjusting, the head bolt (908) must be screwed out. Now the adjusting screw (166) can be turned by a hexagon socket screw key.

Turn to right (clockwise), the opening pressure rises up – turn to left, the opening pressure goes down.

The opening pressure of the valve is adjusted about 10 – 20 % over the operating pressure.

Standard-Einzelaggregate standard single aggregates

KRAL

MF



Lieferumfang:

Flanschpumpe mit eingebautem Sicherheitsventil, Kupplung, Fußlateme und Drehstrommotor, inkl. Gegenflansche.

consisting of:

flange pump with safety valve, coupling, foot lantern and three phase A.C. motor, incl. counter flanges.

MH

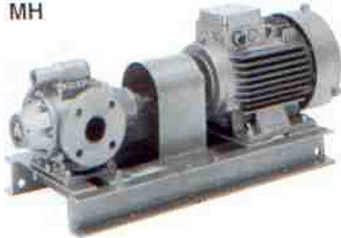

Lieferumfang:

Fußpumpe mit eingebautem Sicherheitsventil, Kupplung, Kupplungsschutz, Grundplatte und Drehstrommotor.

consisting of:

foot pump with safety valve, coupling, coupling protection, base plate and three phase A.C. motor, incl. counter flanges

Die gebräuchlichsten Brenneraggregate mit den entsprechenden Motoren.

The most used oil burning aggregates with suitable el. motors.

Aggregat-Type aggregate type	Fördermenge l/h bei 30 bar pump capacity l/h at 30 bar			Motordaten bei 380 V motor data at 380 V			Flansche flange		Gewicht weight kg
	6 mm ² /s	75 mm ² /s	380 mm ² /s	kW	Bgr.	ca. A	S/s DN	D/p DN	
Drehzahl / revolutions 1450 min⁻¹/rpm									
MFUG 7,5 + 80-4/0,75	180	378	426	0,75	80	2,0	20	15	18,5
MFUG 10 + 80-4/0,75	276	510	576	0,75	80	2,0	20	15	18,5
MFUG 15 + 90-4/1,1	504	792	870	1,1	90	2,8	40	25	31,5
MFUG 20 + 90-4/1,5	666	1044	1146	1,5	90	3,7	40	25	34,5
MFUG 26 + 100-4/2,2	852	1332	1464	2,2	100	5,2	40	25	40
MFUG 32 + 100-4/2,2	1272	1716	1830	2,2	100	5,2	40	25	41,5
MFUG 42 + 100-4/3	1698	2286	2442	3	100	7,0	40	25	47
MHUG 55 + 112-4/4	2394	3144	3348	4	112	8,9	50	50	80
MHUG 74 + 132-4/5,5	3204	4086	4320	5,5	132	12	50	50	112
MHUG 85 + 132-4/5,5	3666	4572	4818	5,5	132	12	50	50	112
MHUG 118 + 132-4/7,5	5310	6540	6840	7,5	132	16	65	65	124
MHUG 160 + 160-4/11	7440	9120	9540	11	160	22	80	80	185
MHUG 210 + 160-4/15	10200	12060	12600	15	160	30	80	80	203
Drehzahl / revolutions 2900 min⁻¹/rpm									
MFUG 5 + 80-2/1,1	408	558	594	1,1	80	2,55	20	15	19,2
MFUG 7,5 + 90-2/1,5	648	846	900	1,5	90	3,5	20	15	22,5
MFUG 10 + 90-2/1,5	900	1140	1200	1,5	90	3,5	20	15	22,5
MFUG 15 + 90-2/2,2	1434	1722	1800	2,2	90	4,9	40	25	35,5
MFUG 20 + 100-2/3	1890	2268	2364	3	100	6,4	40	25	40,5
MFUG 26 + 112-2/4	2418	2898	3030	4	112	8,1	40	25	45,5
MFUG 32 + 112-2/4	3198	3636	3756	4	112	8,1	40	25	50,5
MFUG 32 + 132-2/5,5	3198	3636	3756	5,5	132	11	40	25	70
MFUG 42 + 132-2/5,5	4266	4848	5004	5,5	132	11	40	25	70
MHUG 55 + 132-2/7,5	5904	6600	6840	7,5	132	15	50	50	118
MHUG 74 + 160-2/11	7680	8580	8820	11	160	22,5	50	50	142
MHUG 85 + 160-2/11	8640	9540	9780	11	160	22,5	50	50	142
MHUG 118 + 160-2/15	12420	13680	13980	15	160	29	65	65	156
MHUG 160 + 180-2/22	17400	19080	19500	22	180	42	80	80	298
MHUG 210 + 200-2/30	23220	25140	25620	30	200	56	80	80	385

Standard Daten: 30 bar, 150 °C, Zulaufdruck max. 7 bar
Drehstrom-Normmotor: nach unserer Wahl
Spannung: 230/400 V bis 2,2 KW
400/690 V ab 3 KW

Drehzahl: 2900 l/min bis 380 mm²/s
1440 l/min bis 380 mm²/s

Andere Werte und Sonderausführungen auf Anfrage

standard data: 30 bar, 150 °C, suction pressure max. 7 bar
our supply
three phase A.C. motor: 230/400 V up to 2,2 KW
voltage: 400/690 V from 3 KW

revolutions: 2900 l/min up to 380 mm²/s
1440 l/min from 380 mm²/s

special design on request

Leistungstabelle 50 Hz

performance characteristics 50 Hz

		950 min ⁻¹ /rpm									1450 min ⁻¹ /rpm									2900 min ⁻¹ /rpm								
		6,2			75			380			6,2			75			380			6,2			75			380		
		mm ² /s			mm ² /s			mm ² /s			mm ² /s			mm ² /s			mm ² /s			mm ² /s			mm ² /s			mm ² /s		
Größe	p	Q	P	NPSH	Q	P	NPSH	Q	P	NPSH	Q	P	NPSH	Q	P	NPSH	Q	P	NPSH	Q	P	NPSH	Q	P	NPSH	Q	P	NPSH
size	bar	l/min	kW	m	l/min	kW	m	l/min	kW	m	l/min	kW	m	l/min	kW	m	l/min	kW	m	l/min	kW	m	l/min	kW	m	l/min	kW	m
5	5	-	-	-	-	-	-	-	-	-	3,8	0,07	2	4,7	0,08	2	5,0	0,10	2	9,0	0,17	2	10,0	0,18	2	10,2	0,24	2
	10	-	-	-	-	-	-	-	-	-	3,1	0,11	2	4,5	0,12	2	4,9	0,14	2	8,3	0,25	2	9,8	0,27	2	10,1	0,33	2
	20	-	-	-	-	-	-	-	-	-	2,3	0,20	2	4,3	0,21	2	4,8	0,23	2	7,5	0,43	2	9,5	0,44	2	10,0	0,50	2
	30	-	-	-	-	-	-	-	-	-	1,6	0,29	2	4,0	0,30	2	4,7	0,32	2	6,8	0,60	2	9,3	0,62	2	9,9	0,68	2
	40	-	-	-	-	-	-	-	-	-	-	-	-	3,9	0,38	2	4,6	0,40	2	6,2	0,77	2	9,1	0,79	2	9,8	0,85	2
7,5	5	-	-	-	4,5	0,07	2	4,8	0,09	2	5,9	0,11	2	7,2	0,12	2	7,5	0,15	2	13,7	0,25	2	15,0	0,27	2	15,4	0,36	2,3
	10	-	-	-	4,2	0,11	2	4,7	0,13	2	5,0	0,17	2	6,9	0,18	2	7,4	0,21	2	12,9	0,38	2	14,8	0,41	2	15,3	0,49	2,3
	20	-	-	-	3,8	0,20	2	4,6	0,21	2	3,9	0,30	2	6,5	0,31	2	7,3	0,34	2	11,7	0,64	2	14,4	0,67	2	15,1	0,75	2,3
	30	-	-	-	3,6	0,28	2	4,4	0,30	2	3,0	0,43	2	6,3	0,44	2	7,1	0,47	2	10,8	0,90	2	14,1	0,93	2	15,0	1,01	2,3
	40	-	-	-	3,3	0,37	2	4,3	0,39	2	2,3	0,56	2	6,0	0,57	2	7,0	0,60	2	10,1	1,16	2	13,8	1,19	2	14,9	1,27	2,3
10	5	-	-	-	6,1	0,09	2	6,5	0,11	2	8,0	0,14	2	9,7	0,16	2	10,1	0,20	2	18,5	0,33	2	20,1	0,37	2	20,5	0,48	2,6
	10	-	-	-	5,7	0,15	2	6,3	0,17	2	7,0	0,23	2	9,3	0,24	2	9,9	0,28	2	17,5	0,51	2	19,8	0,54	2	20,4	0,65	2,6
	20	-	-	-	5,3	0,26	2	6,1	0,29	2	5,6	0,40	2	8,9	0,42	2	9,7	0,46	2	16,1	0,85	2	19,3	0,89	2	20,2	1,00	2,6
	30	-	-	-	4,9	0,38	2	6,0	0,40	2	4,6	0,58	2	8,5	0,59	2	9,6	0,63	2	15,0	1,20	2	19,0	1,24	2	20,0	1,35	2,6
	40	-	-	-	4,6	0,49	2	5,9	0,51	2	3,6	0,75	2	8,2	0,76	2	9,5	0,80	2	14,1	1,55	2	18,7	1,58	2	19,9	1,70	2,6
15	5	7,3	0,12	2	9,2	0,13	2	9,7	0,16	2	12,6	0,20	2	14,6	0,22	2	15,1	0,27	2	28,1	0,47	2	30,1	0,51	2	30,6	0,66	2,6
	10	6,1	0,21	2	8,8	0,22	2	9,6	0,25	2	11,4	0,33	2	14,2	0,35	2	14,9	0,40	2	26,9	0,73	2	29,7	0,77	2	30,4	0,92	2,6
	20	4,4	0,38	2	8,3	0,39	2	9,3	0,41	2	9,7	0,59	2	13,6	0,61	2	14,7	0,66	2	25,2	1,24	2	29,1	1,29	2	30,2	1,44	2,6
	30	4,1	0,55	2	7,9	0,56	2	9,1	0,58	2	8,4	0,85	2	13,2	0,87	2	14,5	0,92	2	23,9	1,76	2	28,7	1,60	2	30,0	1,96	2,6
	40	2,0	0,72	2	7,5	0,72	2	9,0	0,75	2	7,3	1,11	2	12,8	1,12	2	14,3	1,18	2	22,8	2,27	2	28,3	2,32	2	29,8	2,47	2,6
20	5	9,6	0,16	2	12,1	0,17	2	12,8	0,21	2	16,6	0,27	2	19,2	0,29	2	19,8	0,36	2,1	37,0	0,61	2	39,5	0,68	2	40,2	0,87	3,1
	10	8,0	0,27	2	11,6	0,29	2	12,6	0,32	2	15,0	0,44	2	18,6	0,46	2	19,6	0,53	2,1	35,4	0,95	2	39,0	1,02	2	40,0	1,21	3,1
	20	5,8	0,50	2	10,9	0,51	2	12,3	0,55	2	12,8	0,78	2	17,9	0,80	2	19,3	0,87	2,1	33,2	1,63	2	38,3	1,70	2	39,7	1,89	3,1
	30	4,1	0,72	2	10,3	0,73	2	12,0	0,77	2	11,1	1,12	2	17,4	1,14	2	19,1	1,21	2,1	31,5	2,31	2	37,8	2,37	2	39,4	2,57	3,1
	40	2,6	0,94	2	9,9	0,95	2	11,8	0,99	2	9,7	1,46	2	16,9	1,48	2	18,8	1,55	2,1	30,1	2,99	2	37,3	3,05	2	39,2	3,25	3,1
26	5	12,2	0,21	2	15,5	0,22	2	16,4	0,27	2	21,2	0,34	2	24,6	0,37	2	25,4	0,46	2,3	47,3	0,79	2,2	50,6	0,86	2,5	51,5	1,12	3,9
	10	10,2	0,35	2	14,9	0,37	2	16,1	0,41	2	19,2	0,58	2	23,9	0,59	2	25,1	0,68	2,3	45,3	1,22	2,2	50,0	1,30	2,5	51,2	1,55	3,9
	20	7,4	0,64	2	13,9	0,65	2	15,7	0,70	2	16,4	0,99	2	22,9	1,02	2	24,7	1,11	2,3	42,5	2,09	2,2	49,0	2,17	2,5	50,8	2,42	3,9
	30	5,2	0,92	2	13,2	0,94	2	15,4	0,98	2	14,2	1,43	2	22,2	1,46	2	24,4	1,55	2,3	40,3	2,96	2,2	48,3	3,04	2,5	50,5	3,29	3,9
	40	3,4	1,21	2	12,6	1,22	2	15,1	1,27	2	12,4	1,86	2	21,6	1,89	2	24,1	1,98	2,3	38,5	3,83	2,2	47,7	3,91	2,5	50,2	4,18	3,9
32	5	16,6	0,25	2	19,6	0,26	2	20,4	0,32	2	27,6	0,41	2	30,6	0,44	2	31,4	0,54	2,1	59,7	0,93	2	62,7	1,01	2	63,5	1,30	3
	10	14,8	0,42	2	19,0	0,44	2	20,1	0,49	2	25,8	0,67	2	30,0	0,70	2	31,2	0,80	2,1	57,9	1,46	2	62,1	1,55	2	63,2	1,83	3
	20	12,2	0,77	2	18,1	0,79	2	19,7	0,84	2	23,2	1,21	2	29,2	1,24	2	30,8	1,34	2,1	55,3	2,53	2	61,3	2,62	2	62,9	2,90	3
	30	10,2	1,12	2	17,5	1,14	2	19,4	1,19	2	21,2	1,74	2	28,6	1,77	2	30,5	1,87	2,1	53,3	3,60	2	60,6	3,69	2	62,6	3,97	3
	40	8,5	1,47	2	16,9	1,49	2	19,2	1,54	2	19,6	2,28	2	28,0	2,31	2	30,3	2,41	2,1	51,6	4,67	2	60,1	4,76	2	62,3	5,04	3
42	5	22,1	0,33	2	26,1	0,35	2	27,2	0,42	2	36,9	0,54	2	40,8	0,58	2	41,9	0,72	2,3	79,6	1,23	2,2	83,6	1,35	2,5	84,7	1,73	3,9
	10	19,7	0,56	2	25,3	0,59	2	26,8	0,66	2	34,4	0,90	2	40,1	0,94	2	41,6	1,07	2,3	77,2	1,95	2,2	82,8	2,06	2,5	84,3	2,44	3,9
	20	16,2	1,03	2	24,2	1,05	2	26,3	1,12	2	31,0	1,61	2	38,9	1,65	2	41,1	1,78	2,3	73,7	3,37	2,2	81,7	3,49	2,5	83,8	3,87	3,9
	30	13,6	1,50	2	23,3	1,52	2	25,9	1,59	2	28,3	2,32	2	38,1	2,36	2	40,7	2,50	2,3	71,1	4,80	2,2	80,8	4,91	2,5	83,4	5,29	3,9
	40	11,3	1,97	2	22,6	1,99	2	25,6	2,06	2	26,1	3,04	2	37,3	3,08	2	40,4	3,21	2,3	68,8	6,22	2,2	80,1	6,34	2,5	83,1	6,72	3,9
55	5	30,7	0,45	2	35,8	0,47	2	37,2	0,56	2	50,9	0,72	2	56,0	0,78	2	57,4	0,95	2,2	109	1,65	2	114	1,80	2,2	115	2,28	3,4
	10	27,6	0,76	2	34,8	0,79	2	36,8	0,88	2	47,7	1,21	2	55,0	1,27	2	56,9	1,44	2,2	106	2,62	2	113	2,77	2,2	115	3,26	3,4
	20	23,1	1,40	2	33,4	1,43	2	36,1	1,52	2	43,3	2,19	2	53,5	2,24	2	56,3	2,41	2,2	101	4,57	2	112	4,72	2,2	114	5,21	3,4
	30	19,7	2,04	2	32,3	2,07	2	35,6	2,16	2	39,9	3,16	2	52,4	3,21	2	55,8	3,39	2,2	98,4	6,52	2	110	6,67	2,2	114	7,15	3,4
	40	16,9	2,68	2	31,3	2,71	2	35,2	2,80	2	37,0	4,14	2	51,5	4,19	2	55,4	4,36	2,2	95,5	8,47	2	109	8,62				

Leistungstabelle 60 Hz performance characteristics 60 Hz



		1150 min ⁻¹ /rpm									1740 min ⁻¹ /rpm									3500 min ⁻¹ /rpm								
		6,2 mm ³ /s			75 mm ³ /s			380 mm ³ /s			6,2 mm ³ /s			75 mm ³ /s			380 mm ³ /s			6,2 mm ³ /s			75 mm ³ /s			380 mm ³ /s		
Größe size	p bar	Q l/min	P kW	NPSH _E m	Q l/min	P kW	NPSH _E m	Q l/min	P kW	NPSH _E m	Q l/min	P kW	NPSH _E m	Q l/min	P kW	NPSH _E m	Q l/min	P kW	NPSH _E m	Q l/min	P kW	NPSH _E m	Q l/min	P kW	NPSH _E m	Q l/min	P kW	NPSH _E m
5	5	-	-	-	-	-	-	-	-	-	4,8	0,09	2	5,8	0,10	2	6,0	0,12	2	11,1	0,21	2	12,1	0,23	2	12,4	0,31	2,1
	10	-	-	-	-	-	-	-	-	-	4,2	0,14	2	5,6	0,15	2	6,0	0,18	2	10,5	0,31	2	11,9	0,34	2	12,3	0,41	2,1
	20	-	-	-	-	-	-	-	-	-	3,3	0,25	2	5,3	0,25	2	5,8	0,28	2	9,6	0,52	2	11,6	0,55	2	12,2	0,62	2,1
	30	-	-	-	-	-	-	-	-	-	2,6	0,35	2	5,1	0,36	2	5,7	0,38	2	9,0	0,73	2	11,4	0,76	2	12,1	0,83	2,1
	40	-	-	-	-	-	-	-	-	-	2,1	0,45	2	4,9	0,46	2	5,7	0,49	2	8,4	0,94	2	11,2	0,97	2	12,0	1,04	2,1
7,5	5	-	-	-	5,6	0,09	2	5,9	0,11	2	7,4	0,13	2	8,8	0,15	2	9,1	0,19	2	16,9	0,31	2	18,3	0,35	2	18,6	0,46	2,5
	10	-	-	-	5,3	0,14	2	5,8	0,16	2	6,6	0,21	2	8,5	0,22	2	9,0	0,26	2	16,1	0,47	2	18,0	0,51	2	18,5	0,62	2,5
	20	-	-	-	4,9	0,24	2	5,6	0,26	2	5,5	0,37	2	8,1	0,38	2	8,8	0,42	2	15,0	0,79	2	17,6	0,82	2	18,3	0,93	2,5
	30	-	-	-	4,6	0,35	2	5,5	0,37	2	4,6	0,52	2	7,8	0,54	2	8,7	0,58	2	14,1	1,10	2	17,3	1,14	2	18,2	1,25	2,5
	40	-	-	-	4,4	0,45	2	5,4	0,47	2	3,8	0,68	2	7,6	0,69	2	8,6	0,73	2	13,3	1,42	2	17,1	1,45	2	18,1	1,56	2,5
10	5	-	-	-	7,5	0,12	2	7,9	0,15	2	10,1	0,18	2	11,7	0,19	2	12,2	0,25	2,1	22,8	0,42	2	24,4	0,47	2	24,9	0,62	3
	10	-	-	-	7,2	0,19	2	7,8	0,21	2	9,1	0,28	2	11,4	0,30	2	12,0	0,35	2,1	21,8	0,63	2	24,1	0,69	2	24,7	0,83	3
	20	-	-	-	6,7	0,32	2	7,6	0,35	2	7,7	0,49	2	11,0	0,51	2	11,8	0,56	2,1	20,4	1,05	2	23,6	1,10	2	24,5	1,25	3
	30	-	-	-	6,4	0,46	2	7,4	0,49	2	6,6	0,70	2	10,6	0,72	2	11,7	0,77	2,1	19,3	1,47	2	23,3	1,52	2	24,3	1,67	3
	40	-	-	-	8,1	0,60	2	7,3	0,63	2	5,7	0,91	2	10,3	0,92	2	11,5	0,98	2,1	18,4	1,89	2	23,0	1,94	2	24,2	2,09	3
15	5	9,4	0,15	2	11,4	0,17	2	11,9	0,20	2	15,7	0,25	2	17,7	0,27	2	18,2	0,34	2	34,5	0,59	2	36,5	0,65	2	37,0	0,85	2,9
	10	8,2	0,26	2	11,0	0,27	2	11,7	0,31	2	14,5	0,41	2	17,3	0,43	2	18,0	0,50	2	33,3	0,90	2	36,1	0,96	2	36,8	1,16	2,9
	20	6,5	0,46	2	10,4	0,47	2	11,5	0,51	2	12,8	0,72	2	16,7	0,74	2	17,8	0,81	2	31,6	1,52	2	35,5	1,59	2	36,6	1,78	2,9
	30	5,2	0,67	2	10,0	0,68	2	11,3	0,72	2	11,5	1,03	2	16,3	1,05	2	17,6	1,12	2	30,4	2,15	2	35,1	2,21	2	36,4	2,41	2,9
	40	4,1	0,87	2	9,6	0,88	2	11,1	0,92	2	10,4	1,34	2	15,9	1,36	2	17,4	1,43	2	29,3	2,77	2	34,8	2,83	2	36,2	3,03	2,9
20	5	12,4	0,20	2	14,9	0,22	2	15,6	0,27	2	20,7	0,33	2	23,2	0,36	2	23,9	0,45	2,3	45,4	0,77	2,1	48,0	0,86	2,4	48,7	1,12	3,7
	10	10,8	0,34	2	14,4	0,35	2	15,4	0,40	2	19,1	0,54	2	22,7	0,56	2	23,7	0,66	2,3	43,9	1,18	2,1	47,5	1,27	2,4	48,4	1,53	3,7
	20	6,6	0,61	2	13,7	0,62	2	15,1	0,67	2	16,9	0,94	2	22,0	0,97	2	23,4	1,06	2,3	41,6	2,00	2,1	46,8	2,09	2,4	48,1	2,35	3,7
	30	6,9	0,88	2	13,2	0,89	2	14,8	0,94	2	15,2	1,35	2	21,5	1,38	2	23,1	1,47	2,3	39,9	2,82	2,1	46,2	2,91	2,4	47,9	3,17	3,7
	40	5,5	1,15	2	12,7	1,16	2	14,6	1,21	2	13,7	1,76	2	21,0	1,79	2	22,9	1,88	2,3	38,5	3,64	2,1	45,7	3,73	2,4	47,7	3,99	3,7
26	5	15,8	0,26	2	19,1	0,28	2	20,0	0,34	2,1	26,5	0,42	2	29,7	0,46	2	30,6	0,58	2,6	58,1	0,99	2,7	61,4	1,09	3	62,3	1,43	4,8
	10	13,8	0,43	2	18,5	0,45	2	19,7	0,52	2,1	24,5	0,69	2	29,1	0,72	2	30,3	0,84	2,6	56,1	1,52	2,7	60,8	1,62	3	62,0	1,96	4,8
	20	11,0	0,78	2	17,5	0,80	2	19,3	0,86	2,1	21,6	1,21	2	28,2	1,24	2	29,9	1,36	2,6	53,3	2,57	2,7	59,8	2,67	3	61,6	3,01	4,8
	30	8,8	1,12	2	16,8	1,14	2	19,0	1,21	2,1	19,4	1,73	2	27,5	1,77	2	29,6	1,88	2,6	51,1	3,62	2,7	59,1	3,72	3	61,3	4,06	4,8
	40	7,0	1,47	2	16,2	1,49	2	18,7	1,55	2,1	17,6	2,25	2	26,9	2,29	2	29,3	2,41	2,6	49,3	4,67	2,7	58,5	4,77	3	61,0	5,11	4,8
32	5	21,0	0,31	2	24,0	0,33	2	24,8	0,40	2	34,1	0,50	2	37,0	0,54	2	37,8	0,67	2,2	73,0	1,16	2	76,0	1,28	2,3	76,8	1,65	3,5
	10	19,2	0,52	2	23,4	0,54	2	24,5	0,61	2	32,2	0,82	2	36,5	0,86	2	37,6	1,00	2,2	71,2	1,81	2	75,4	1,93	2,3	76,5	2,30	3,5
	20	16,6	0,95	2	22,6	0,97	2	24,2	1,04	2	29,6	1,46	2	35,6	1,51	2	37,2	1,64	2,2	68,6	3,10	2	74,5	3,22	2,3	76,1	3,59	3,5
	30	14,6	1,37	2	21,9	1,39	2	23,9	1,46	2	27,7	2,11	2	35,0	2,15	2	36,9	2,28	2,2	66,6	4,39	2	73,9	4,51	2,3	75,6	4,88	3,5
	40	12,9	1,79	2	21,4	1,82	2	23,6	1,89	2	26,0	2,75	2	34,4	2,79	2	36,7	2,92	2,2	64,9	5,68	2	73,3	5,80	2,3	75,6	6,17	3,5
42	5	28,0	0,41	2	32,0	0,44	2	33,1	0,54	2,1	45,4	0,67	2	49,4	0,72	2	50,5	0,90	2,6	97,3	1,55	2,7	101	1,71	3	102	2,21	4,8
	10	25,6	0,70	2	31,2	0,72	2	32,7	0,82	2,1	43,0	1,10	2	48,6	1,15	2	50,1	1,33	2,6	94,9	2,41	2,7	100	2,57	3	102	3,07	4,8
	20	22,1	1,26	2	30,1	1,29	2	32,2	1,38	2,1	39,5	1,95	2	47,5	2,01	2	49,6	2,18	2,6	91,4	4,13	2,7	99,4	4,29	3	101	4,79	4,8
	30	19,5	1,83	2	29,2	1,86	2	31,8	1,95	2,1	36,9	2,81	2	46,8	2,86	2	49,2	3,04	2,6	88,8	5,85	2,7	98,5	6,01	3	101	6,51	4,8
	40	17,2	2,39	2	28,5	2,42	2	31,5	2,51	2,1	34,6	3,66	2	45,9	3,72	2	48,9	3,89	2,6	86,5	7,57	2,7	97,8	7,73	3	100	8,23	4,8
55	5	38,6	0,55	2	43,9	0,59	2	45,3	0,71	2	62,6	0,90	2	67,7	0,97	2	69,1	1,19	2,4	133	2,07	2,3	138	2,27	2,6	140	2,91	4,1
	10	35,6	0,94	2	42,9	0,98	2	44,8	1,10	2	59,4	1,48	2	66,7	1,55	2	68,6	1,78	2,4	130	3,24	2,3	137	3,44	2,6	139	4,09	4,1
	20	22,1	1,26	2	41,4	1,75	2	44,2	1,87	2	55,0	2,65	2	65,2	2,72	2	68,0	2,95	2,4	126	5,60	2,3	136	5,80	2,6	138	6,44	4,1
	30	27,8	2,49	2	40,3	2,52	2	43,7	2,65	2	51,6	3,82	2	64,1	3,89	2	67,5	4,12	2,4	122	7,95	2,3	135	8,15	2,6	138	8,79	4,1
	40	24,9	3,26	2	39,4	3,30	2	43,3	3,42	2	48,7	4,99	2	63,2	5,06	2	67,1	5,29	2,4	119	10,3	2,3	134	10,5	2,6	138	11,1	4,1
74	5	50,7	0,71	2	56,7	0,76	2	58,3	0,92	2,2	81,3	1,15	2	87,3	1,24	2	88,9	1,53	2,8	172	2,66	3,1	178	2,91	3,5	180	3,74	5,6
	10	47,0	1,21	2	55,5	1,28	2	57,8	1,41	2,2	77,6	1,91	2	86,1	2,00	2	88,4	2,29	2,8	168	4,17	3,1	177	4,43	3,5	179	5,25	5,6
	20	41,8	2,20	2	53,8	2,25	2	57,0	2,41	2,2	72,4	3,41	2	84,4	3,50	2	87,6	3,79	2,8	163	7,19	3,1	175	7,45	3,5	178	8,28	5,6
	30	37,8	3,20	2	52,5	3,25	2	56,5	3,40	2,2	68,4	4,91	2	83,1	5,00	2	87,1	5,29	2,8	159	10,2	3,1	174	10,4	3,5	178	11,3	5,6
	40	34,5	4,19	2	51,4	4,24	2	56,0	4,39	2,2	65,1	6,42	2	82,0	6,51	2	86,6	6,80	2,8	156	13,2	3,1	173	13,5	3,5	177	14,3	5,6
85	5	57,1	0,79	2	63,3	0,85	2	64,9	1,02	2,3	91,1	1,28	2	97,2	1,38	2	98,9											

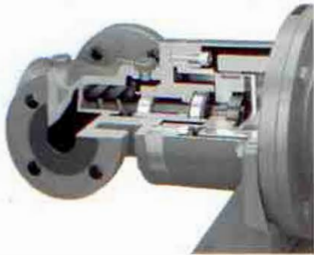

Schraubenspindelpumpen mit Magnetkupplung

max. Druck 100 bar
 max. Fördermenge 2900 l/min

Anwendung:
 Für Schweröle und Wärmeträgeröle, sowie für Polyurethan.

Screw pumps with magnetic coupling

max. pressure 100 bar
 max. capacity 2900 l/min

Application:
 For heavy fuel oils and thermal oils, as well for Polyurethane.



Schraubenspindelpumpen Baureihe K

max. Druck 16 bar
 max. Fördermenge 2900 l/min

Anwendung:
 Für Heizöle (Leicht bis Schwer) als Transfer-Ringleitungs- und Brennerpumpen. Für Schmier- und Hydrauliköle.

Screw pumps series K

max. pressure 16 bar
 max. capacity 2900 l/min

Application:
 For fuel oil (light and heavy) as transfer, circular pipeline- and burner pumps. For lubrication and hydraulic oil.



Schraubenspindelpumpen Baureihe Doppelstationen

max. Druck 40 bar
 max. Fördermenge 7000 l/h

Anwendung:
 Für Heizöle (Leicht bis Schwer) als Transfer, Ringleitungs- und Brennerpumpen.

Screw pumps series double-stations

max. pressure 40 bar
 max. capacity 7000 l/h

Application:
 For fuel oil (light and heavy) as transfer, circular pipeline- and burner pumps.



Schraubenspindelpumpen Baureihe C

max. Druck 100 bar
 max. Fördermenge 2000 l/min

Anwendung:
 Für Heizöle (Leicht bis Schwer) als Transfer-, Entlade-, Ringleitungs- und Brennerpumpen. Für Schmieröle, Hydrauliköle sowie Medien mit schmierenden Eigenschaften.

Screw pumps series C

max. pressure 100 bar
 max. capacity 2000 l/min

Application:
 For fuel oil (light and heavy) as transfer discharge-, circular pipeline- and burner pumps. For lubrication- and hydraulic oil as well as mediums with lubricating features.



Mengenmeßsysteme Baureihe OM

max. Druck 420 bar
 Meßbereich 0,1-7500 l/min

Anwendung:
 Für Flüssigkeiten

Flowmeter systems series OM

max. pressure 420 bar
 measurung 0,1-7500 l/min
 range

Application:
 For liquids

überreicht durch / presented by:

AUSTRALIAN DISTRIBUTOR



KelairPumps

CALL 1300 789 466

When Pump Knowledge Matters
 www.kelairpumps.com.au