

DOUBLEBOX PLUS

Series

3

Prefabricated lifting station for wastewater in compliance with EN 12050-1/2 standard.

Specifications

The standard station is equipped with:

- polyethylene basin with a capacity of 550 litres, equipped with two threaded pedestrian covers (100 kg max).
- Cable glands for power supply cables (and floats).
- 2x Rp 1 1/2 or 2" delivery pipes with fast connections and ring nuts for easy disassembly of the pumps or with sliding device.
- 8 fast connections:
 - 4 x DN110 for inlet,
 - 2 x DN50 for ventilation and
 - 2 x DN65 for cable connection.
- 1 x DN50 fast connection for the manual pump.
- 2x DOMO or DL submersible pumps, vortex, channel impeller type or with grinder device.
- QXR2 control panel for three-phase versions.
- 3 rubber seal:
 - 1 x DN110, 1 x DN50 and
 - 1 x DN65 mm.

Special versions equipped with delivery pipes, ball check valve and gate valve.

Special versions equipped with sliding device and non-return ball valve.

Doublebox plus can be installed on the floor or buried in a suitable structure following instructions in the "Instructions and Operative Manual".

Easy installation:

- installation is quick and easy:
 - for the single-phase versions you just connect the pipes and the electrical cables; for the three-phase versions you also need to connect the control panel.
- The new Doublebox plus is provided side handles for ease of handling.
- Pre-installed delivery pump and unions.

Ecological solution:

- tank made from 100% recyclable polyethylene.
- Airtight anti-pollution tank, pursuant to European standard EN 12050.

Easy maintenance and repair.

- Tried and tested pump technology.
- Pump quick and easy to remove thanks to the ring nut located near the cover.

Accessories

Ball check valves

Alarm kit

Manual pump + seal

Seals kit



DOUBLEBOX PLUS SERIES

Table chart

DOUBLEBOX PLUS

DATA REFERS TO 2 PUMPS RUNNING SIMULTANEOUSLY

3

		CHARACTERISTICS					FEATURED COMPONENTS			VERSIONS				
		kw	HP	Q max (l/min)	H max (m)	Impeller type	Control panel	Float pre-assembled on pump	Float (10 m cable)	Standard with ring nut	Ring nut, non-return valve and gate valve	Standard	With non-return valve	
FIXED PVC PIPE FITTINGS	SINGLE-PHASE	DOUBLEBOX PLUS DOMO 7	2x0,55	2x0,75	640	10,7	TWIN CHANNEL		X		X	X		
		DOUBLEBOX PLUS DOMO 7VX	2x0,55	2x0,75	520	9,1	VORTEX		X		X	X		
		DOUBLEBOX PLUS DOMO 10	2x0,75	2x1	1000	10,1	TWIN CHANNEL		X		X	X		
		DOUBLEBOX PLUS DOMO 10VX	2x0,75	2x1	800	7,7	VORTEX		X		X	X		
		DOUBLEBOX PLUS DOMO 15	2x1,1	2x1,5	1200	12,7	TWIN CHANNEL		X		X	X		
		DOUBLEBOX PLUS DOMO 15VX	2x1,1	2x1,5	900	9,1	VORTEX		X		X	X		
		DOUBLEBOX PLUS DOMO GRI 11	2x1,1	2x1,5	220	25	GRINDER		X		X	X		
	THREE-PHASE	DOUBLEBOX PLUS DOMO 7T	2x0,55	2x0,75	640	10,7	TWIN CHANNEL	X		X	X	X		
		DOUBLEBOX PLUS DOMO 7VXT	2x0,55	2x0,75	520	9,1	VORTEX	X		X	X	X		
		DOUBLEBOX PLUS DOMO 10T	2x0,75	2x1	1000	10,1	TWIN CHANNEL	X		X	X	X		
		DOUBLEBOX PLUS DOMO 10VXT	2x0,75	2x1	800	7,7	VORTEX	X		X	X	X		
		DOUBLEBOX PLUS DOMO 15T	2x1,1	2x1,5	1200	12,7	TWIN CHANNEL	X		X	X	X		
		DOUBLEBOX PLUS DOMO 15VXT	2x1,1	2x1,5	900	9,1	VORTEX	X		X	X	X		
		DOUBLEBOX PLUS DOMO 20T	2x1,5	2x2	1340	14,8	TWIN CHANNEL	X		X	X	X		
	THREE-PHASE	DOUBLEBOX PLUS DOMO 20VXT	2x1,5	2x2	1100	11	VORTEX	X		X	X	X		
		DOUBLEBOX PLUS DOMO GRI 11T	2x1,1	2x1,5	220	25	GRINDER	X		X	X	X		
		SINGLE-PHASE	DOUBLEBOX PLUS DOMO 10	2x0,75	2x1	1000	10,1	TWIN CHANNEL		X			X	X
			DOUBLEBOX PLUS DOMO 10VX	2x0,75	2x1	800	7,7	VORTEX		X			X	X
			DOUBLEBOX PLUS DOMO 15	2x1,1	2x1,5	1200	12,7	TWIN CHANNEL		X			X	X
			DOUBLEBOX PLUS DOMO 15VX	2x1,1	2x1,5	900	9,1	VORTEX		X			X	X
DOUBLEBOX PLUS DOMO GRI 11			2x1,1	2x1,5	220	25	GRINDER		X			X	X	
THREE-PHASE	DOUBLEBOX PLUS DOMO 10T		2x0,75	2x1	1000	10,1	TWIN CHANNEL	X		X		X	X	
	DOUBLEBOX PLUS DOMO 10VXT		2x0,75	2x1	800	7,7	VORTEX	X		X		X	X	
	DOUBLEBOX PLUS DOMO 15T	2x1,1	2x1,5	1200	12,7	TWIN CHANNEL	X		X		X	X		
	DOUBLEBOX PLUS DOMO 15VXT	2x1,1	2x1,5	900	9,1	VORTEX	X		X		X	X		
	DOUBLEBOX PLUS DOMO 20T	2x1,5	2x2	1340	14,8	TWIN CHANNEL	X		X		X	X		
	DOUBLEBOX PLUS DOMO 20VXT	2x1,5	2x2	1100	11	VORTEX	X		X		X	X		
	DOUBLEBOX PLUS DOMO GRI 11T	2x1,1	2x1,5	220	25	GRINDER	X		X		X	X		
LOWERING DEVICE	SINGLE-PHASE	DOUBLEBOX PLUS DLFM 80	2x0,6	2x0,8	700	7,6	SINGLE CHANNEL		X			X	X	
		DOUBLEBOX PLUS DLFM 90	2x0,6	2x0,8	900	9,7	SINGLE CHANNEL		X			X	X	
		DOUBLEBOX PLUS MINI VORTEX M	2x0,6	2x0,8	600	7,2	VORTEX		X			X	X	
		DOUBLEBOX PLUS DLM 109	2x1,1	2x1,5	1200	18,3	SINGLE CHANNEL		X			X	X	
		DOUBLEBOX PLUS DLVM 100	2x1,1	2x1,5	1000	10,6	VORTEX		X			X	X	
	THREE-PHASE	DOUBLEBOX PLUS DLF 80	2x0,6	2x0,8	700	7,6	SINGLE CHANNEL	X		X		X	X	
		DOUBLEBOX PLUS DLF 90	2x0,6	2x0,8	900	9,7	SINGLE CHANNEL	X		X		X	X	
		DOUBLEBOX PLUS MINI VORTEX	2x0,6	2x0,8	600	7,2	VORTEX	X		X		X	X	
		DOUBLEBOX PLUS DLF 105	2x1,1	2x1,5	1000	14,1	SINGLE CHANNEL	X		X		X	X	
		DOUBLEBOX PLUS DL 109	2x1,1	2x1,5	1200	18,3	SINGLE CHANNEL	X		X		X	X	
		DOUBLEBOX PLUS DLV 100	2x1,1	2x1,5	1000	10,6	VORTEX	X		X		X	X	
		DOUBLEBOX PLUS DLF VORTEX	2x1,1	2x1,5	1000	8,4	VORTEX	X		X		X	X	
		DOUBLEBOX PLUS DL 125	2x1,5	2x2	1400	21,9	SINGLE CHANNEL	X		X		X	X	
		DOUBLEBOX PLUS DLV 115	2x1,5	2x2	1200	13,1	VORTEX	X		X		X	X	

dbboxplus_modelli_c_sc

Notes

Single-phase pumps come with start capacitor, overload protection and float switch. Versions with control panel and accessories are available on request.

DOUBLEBOX PLUS SERIES DOMO-DOMO VX

Operating characteristics at 50 Hz

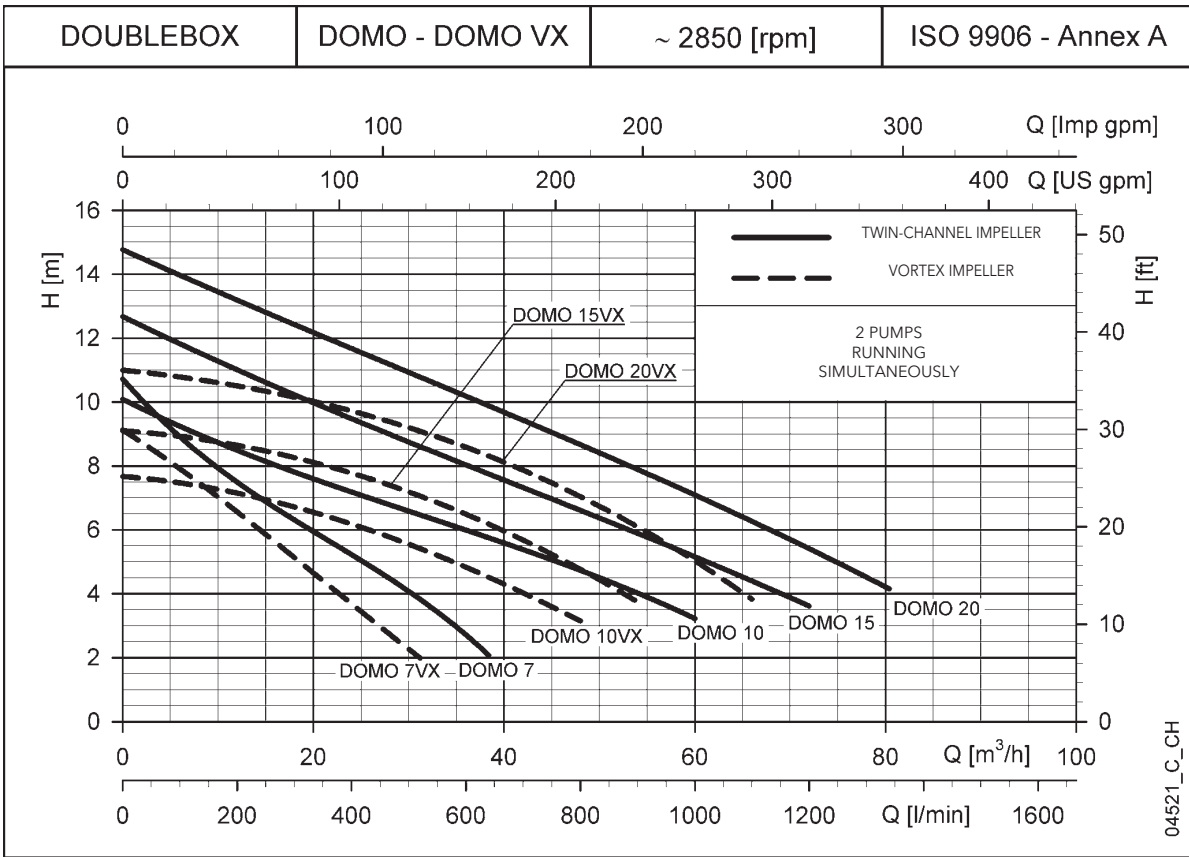

Hydraulic performance table

DOMO	PUMP TYPE	RATED POWER		Q = DELIVERY												
				H = TOTAL HEAD METRES COLUMN OF WATER												
				l/min	0	100	200	300	400	500	600	640	800	1000	1200	1340
		kW	HP	m ³ /h	0	6	12	18	24	30	36	38,4	48	60	72	80,4
	DOMO 7(T)	2x0,55	2x0,75	10,7	8,9	7,5	6,3	5,2	4,1	2,7	2,1					
	DOMO 10(T)	2x0,75	2x1	10,1	9,2	8,5	7,8	7,2	6,6	6,0	5,8	4,7	3,2			
	DOMO 15(T)	2x1,1	2x1,5	12,7	11,8	11,0	10,2	9,5	8,8	8,0	7,8	6,6	5,2	3,6		
	DOMO 20T	2x1,5	2 x 2	14,8	14,0	13,2	12,4	11,7	10,9	10,2	9,9	8,7	7,1	5,4	4,2	

DOMO VX	PUMP TYPE	RATED POWER		Q = DELIVERY												
				H = TOTAL HEAD METRES COLUMN OF WATER												
				l/min	0	160	200	300	350	400	450	520	600	800	900	1100
		kW	HP	m ³ /h	0	9,6	12	18	21	24	27	31,2	36	48	54	66
	DOMO 7VX(T)	2x0,55	2x0,75	9,1	7,1	6,6	5,1	4,4	3,7	3,0	2,0					
	DOMO 10VX(T)	2x0,75	2x1	7,7	7,3	7,1	6,7	6,5	6,2	5,9	5,4	4,8	3,1			
	DOMO 15VX(T)	2x1,1	2x1,5	9,1	8,8	8,6	8,3	8,0	7,8	7,5	7,1	6,5	4,8	3,7		
	DOMO 20VXT	2x1,5	2 x 2	11,0	10,6	10,5	10,2	9,9	9,7	9,5	9,1	8,6	7,0	6,1	3,8	

These performances (referred to the single pump) are valid for liquids with density $\rho = 1,0 \text{ kg/dm}^3$ and kinematic viscosity $\nu = 1 \text{ mm}^2/\text{s}$.

dbox_domo-domovx-2p50_a_th

Electrical data

PUMP TYPE	ABSORBED POWER*		CAPACITOR	PUMP TYPE	ABSORBED POWER*		ABSORBED CURRENT* 380-415V A
	SINGLE-PHASE	ABSORBED CURRENT* 220-240 V A			THREE-PHASE	ABSORBED CURRENT* 220-240 V A	
	kW	$\mu\text{F} / 450 \text{ V}$			kW	A	
DOMO 7	2x0,8	2x3,94	2x16	DOMO 7T	2x0,73	2x2,58	2x1,49
DOMO 10	2x1,14	2x5,84	2x22	DOMO 10T	2x1,09	2x4,09	2x2,36
DOMO 15	2x1,58	2x7,02	2x30	DOMO 15T	2x1,49	2x4,73	2x2,73
-	-	-	-	DOMO 20T	2x1,96	2x6,6	2x3,81
DOMO 7VX	2x0,79	2x3,91	2x16	DOMO 7VXT	2x0,71	2x2,56	2x1,48
DOMO 10VX	2x1,15	2x5,88	2x22	DOMO 10VXT	2x1,1	2x4,09	2x2,36
DOMO 15VX	2x1,36	2x6,11	2x30	DOMO 15VXT	2x1,26	2x4,31	2x2,49
-	-	-	-	DOMO 20VXT	2x1,74	2x6,22	2x3,59

*Maximum values within operating range.

dbox_domo-domovx-2p50_a_te

DOUBLEBOX PLUS SERIES DOMO GRI

Operating characteristics at 50 Hz

3

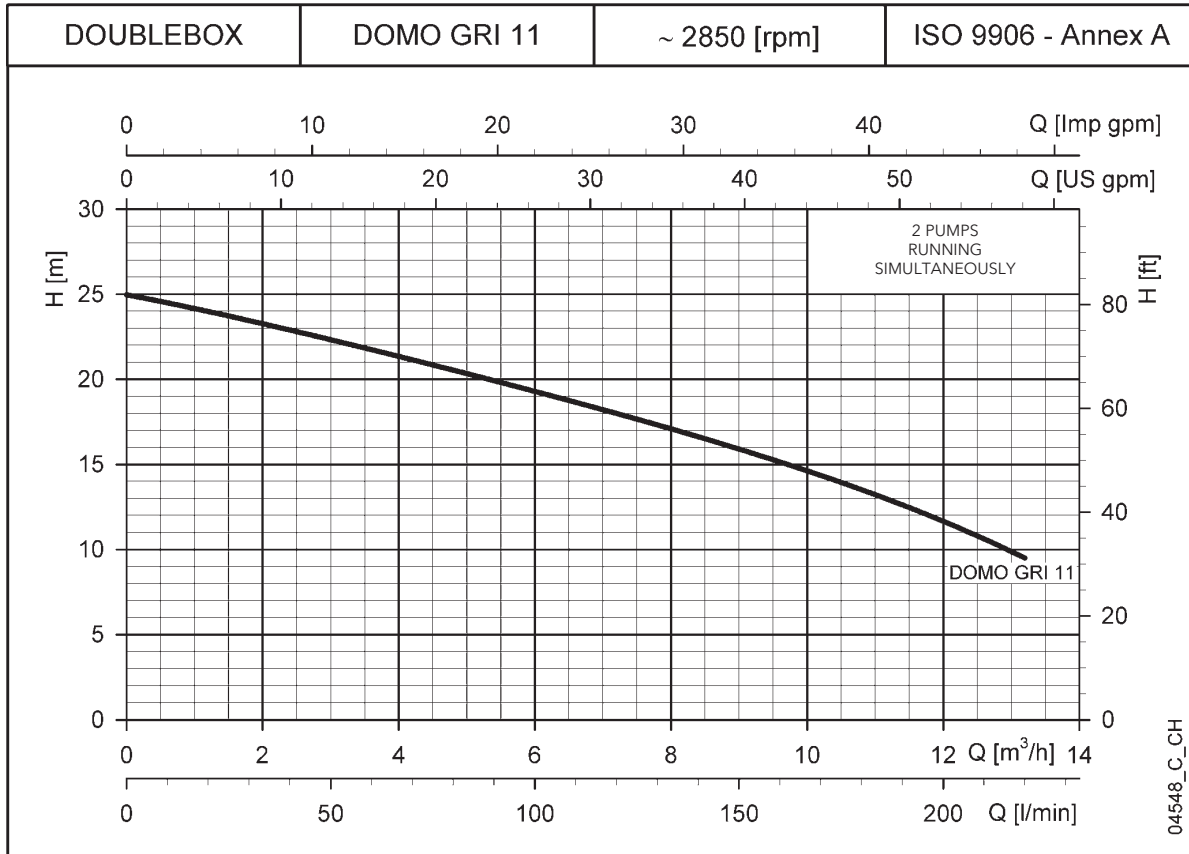

Hydraulic performance table

DOMO GRI	PUMP TYPE	RATED POWER		Q = DELIVERY											
				H = TOTAL HEAD METRES COLUMN OF WATER											
				l/min	0	30	60	80	100	120	140	160	180	200	220
				m3/h	0	1,8	3,6	4,8	6	7,2	8,4	9,6	10,8	12	13,2
		kW	HP		25,0	23,5	21,7	20,5	19,3	18,0	16,6	15,2	13,5	11,7	9,5
	DOMO GRI11	2x1,1	2x1,5												
	DOMO GRI11T														

These performances (referred to the single pump) are valid for liquids with density $\rho = 1,0 \text{ kg/dm}^3$ and kinematic viscosity $\nu = 1 \text{ mm}^2/\text{s}$.

dbox_domo-gri-2p50_b_th

Electrical data

PUMP TYPE	ABSORBED POWER*	ABSORBED CURRENT*	CAPACITOR	PUMP TYPE	ABSORBED POWER*	ABSORBED CURRENT*	ABSORBED CURRENT*
SINGLE-PHASE		220-240 V		THREE-PHASE		220-240 V	380-415 V
	kW	A	$\mu\text{F} / 450 \text{ V}$		kW	A	A
DOMO GRI11	2x1,5	2x6,84	2x30	DOMO GRI11T	2x1,39	2x4,55	2x2,63

*Maximum values within operating range.

dbox_domo-gri-2p50_a_te

DOUBLEBOX PLUS SERIES DL-DLV

Operating characteristics at 50 Hz

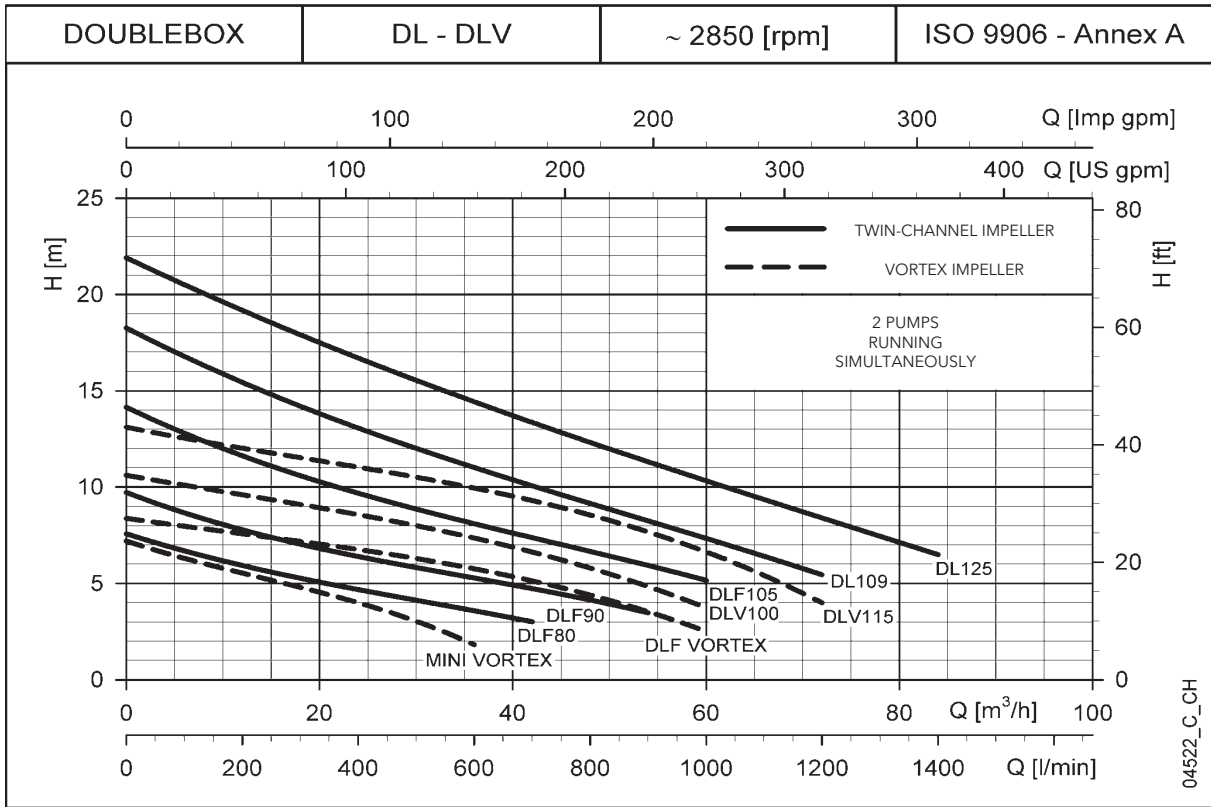

Hydraulic performance table

PUMP TYPE	RATED POWER		Q = DELIVERY												
			l/min	0	200	300	400	500	600	700	800	900	1000	1200	1400
			m³/h	0	12	18	24	30	36	42	48	54	60	72	84
H = TOTAL HEAD METRES COLUMN OF WATER															
DL	DLF(M) 80	2x0,6	2x0,8	7,6	5,9	5,3	4,7	4,1	3,6	3,0					
	DLF(M) 90	2x0,6	2x0,8	9,7	7,8	7,0	6,4	5,8	5,3	4,7	4,1	3,5			
	DLF 105	2x1,1	2x1,5	14,1	11,6	10,6	9,7	8,9	8,1	7,4	6,7	5,9	5,2		
	DL(M) 109	2x1,1	2x1,5	18,3	15,4	14,2	13,1	12,0	11,0	10,1	9,2	8,2	7,3	5,4	
	DL 125	2x1,5	2x2	21,9	19,2	17,9	16,7	15,5	14,4	13,4	12,3	11,3	10,3	8,4	6,5

PUMP TYPE	RATED POWER		Q = DELIVERY												
			l/min	0	100	200	300	400	500	600	700	800	900	1000	1200
			m³/h	0	6	12	18	24	30	36	42	48	54	60	72
H = TOTAL HEAD METRES COLUMN OF WATER															
DLV	MINI VORTEX(M)	2x0,6	2x0,8	7,2	6,3	5,5	4,8	4,0	3,0	1,8					
	DLF VORTEX	2x1,1	2x1,5	8,4	8,0	7,6	7,2	6,8	6,3	5,8	5,1	4,4	3,5	2,5	
	DLV(M) 100	2x1,1	2x1,5	10,6	10,1	9,6	9,1	8,6	8,0	7,4	6,6	5,8	4,8	3,7	
	DLV 115	2x1,5	2x2	13,1	12,5	12,0	11,5	11,0	10,5	9,9	9,3	8,5	7,7	6,6	4,0

These performances (referred to the single pump) are valid for liquids with density $\rho = 1,0 \text{ kg/dm}^3$ and kinematic viscosity $\nu = 1 \text{ mm}^2/\text{s}$. dbox_dl-dlv-2p50_b_th

Electrical data

PUMP TYPE	ABSORBED POWER*		CAPACITOR	PUMP TYPE	ABSORBED POWER*		ABSORBED CURRENT* 220-240 V	ABSORBED CURRENT* 380-415V
	SINGLE-PHASE	kW			A	THREE-PHASE		
DLFM 80	2x0,79	2x3,91	2x25	DLF 80	2x0,8	-	2x2,09	
DLFM 90	2x0,89	2x4,27	2x25	DLF 90	2x0,92	2x3,81	2x2,2	
-	-	-	-	DLF 105	2x1,43	2x4,66	2x2,69	
DLM109	2x1,55	2x6,87	2x35	DL 109	2x1,54	2x5,44	2x3,14	
-	-	-	-	DL 125	2x2,14	2x6,58	2x3,8	
MINI VORTEX M	2x1,05	2x4,82	2x25	MINI VORTEX	2x1,1	-	2x2,36	
-	-	-	-	DLF VORTEX	2x1,66	2x5,11	2x2,95	
DLVM100	2x1,64	2x7,3	2x35	DLV 100	2x1,65	2x5,63	2x3,25	
-	-	-	-	DLV 115	2x2,25	2x6,81	2x3,93	

*Maximum values within operating range.

dbox_dl-dlv-2p50_b_te

DOUBLEBOX PLUS SERIES

Dimensions and weights

3

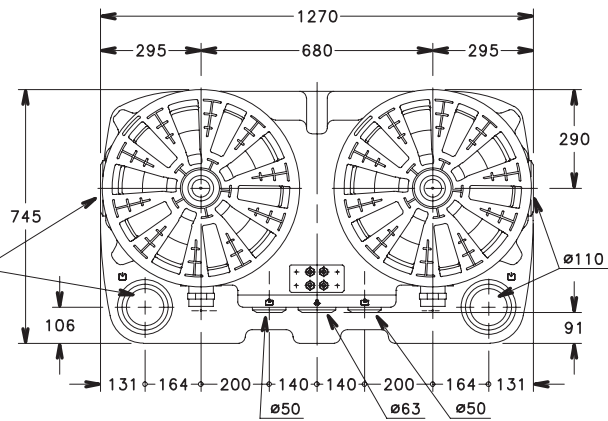
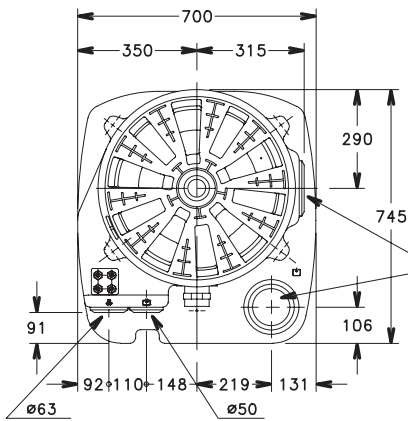
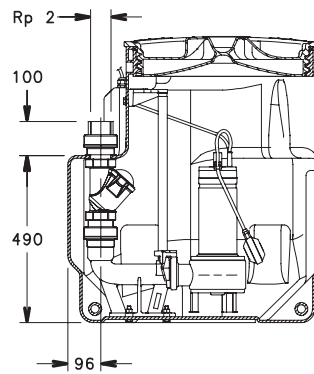
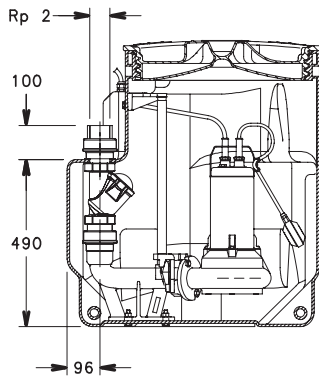
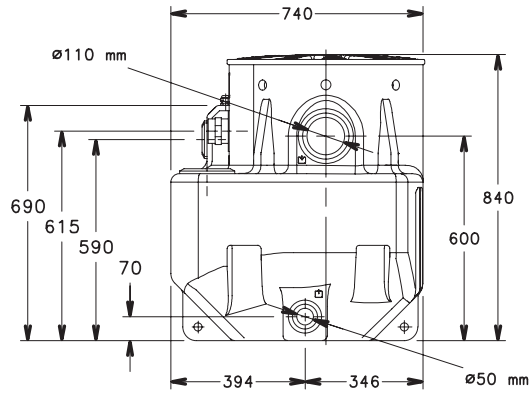
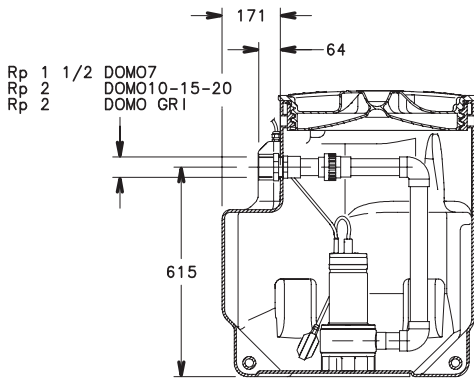

MODEL	WEIGHT (kg)			
	PVC	PVC BV	SL	SL BV
SINGLEBOX PLUS	23	27	32	36
DOUBLEBOX PLUS	44	51	62	69

sbox-dbox_a_td

04514_C_DD

SINGLEBOX PLUS - DOUBLEBOX PLUS SERIES

Certifications

MINIBOX MIDIBOX SINGLEBOX PLUS DOUBLEBOX PLUS

Station	Use
MINIBOX DOC3	Clean water
MINIBOX DOC7	Clean water
MINIBOX DOC7VX	Clean water
MIDIBOX DOC3	Clean water
MIDIBOX DOC7	Clean water
MIDIBOX DOC7T	Clean water
MIDIBOX DOC7VX	EN 12050 - 2
MIDIBOX DOC7VXT	EN 12050 - 2
MIDIBOX DOMO7	EN 12050 - 2
MIDIBOX DOMO7T	EN 12050 - 2
MIDIBOX DOMO7VX	EN 12050 - 2
MIDIBOX DOMO7VXT	EN 12050 - 2
SINGLEBOX PLUS / DOUBLEBOX PLUS DOMO 7	EN 12050 - 2
SINGLEBOX PLUS / DOUBLEBOX PLUS DOMO 7T	EN 12050 - 2
SINGLEBOX PLUS / DOUBLEBOX PLUS DOMO 7VX	EN 12050 - 2
SINGLEBOX PLUS / DOUBLEBOX PLUS DOMO 7VXT	EN 12050 - 2
SINGLEBOX PLUS / DOUBLEBOX PLUS DOMO 10	EN 12050 - 1
SINGLEBOX PLUS / DOUBLEBOX PLUS DOMO 10T	EN 12050 - 1
SINGLEBOX PLUS / DOUBLEBOX PLUS DOMO 10VX	EN 12050 - 1
SINGLEBOX PLUS / DOUBLEBOX PLUS DOMO 10VXT	EN 12050 - 1
SINGLEBOX PLUS / DOUBLEBOX PLUS DOMO 15	EN 12050 - 1
SINGLEBOX PLUS / DOUBLEBOX PLUS DOMO 15T	EN 12050 - 1
SINGLEBOX PLUS / DOUBLEBOX PLUS DOMO 15VX	EN 12050 - 1
SINGLEBOX PLUS / DOUBLEBOX PLUS DOMO 15VXT	EN 12050 - 1
SINGLEBOX PLUS / DOUBLEBOX PLUS DOMO 20T	EN 12050 - 1
SINGLEBOX PLUS / DOUBLEBOX PLUS DOMO 20VXT	EN 12050 - 1
SINGLEBOX PLUS / DOUBLEBOX PLUS DOMO GRI 11	EN 12050 - 1
SINGLEBOX PLUS / DOUBLEBOX PLUS DOMO GRI 11T	EN 12050 - 1
SINGLEBOX PLUS / DOUBLEBOX PLUS DLFM 80	EN 12050 - 2
SINGLEBOX PLUS / DOUBLEBOX PLUS DLF 80	EN 12050 - 2
SINGLEBOX PLUS / DOUBLEBOX PLUS DLFM 90	EN 12050 - 2
SINGLEBOX PLUS / DOUBLEBOX PLUS DLF 90	EN 12050 - 2
SINGLEBOX PLUS / DOUBLEBOX PLUS MINI VORTEX M	EN 12050 - 2
SINGLEBOX PLUS / DOUBLEBOX PLUS MINI VORTEX	EN 12050 - 2
SINGLEBOX PLUS / DOUBLEBOX PLUS DLF 105	EN 12050 - 2
SINGLEBOX PLUS / DOUBLEBOX PLUS DLM 109	EN 12050 - 2
SINGLEBOX PLUS / DOUBLEBOX PLUS DL 109	EN 12050 - 2
SINGLEBOX PLUS / DOUBLEBOX PLUS DLVM 100	EN 12050 - 2
SINGLEBOX PLUS / DOUBLEBOX PLUS DLV 100	EN 12050 - 2
SINGLEBOX PLUS / DOUBLEBOX PLUS DLF VORTEX	EN 12050 - 2
SINGLEBOX PLUS / DOUBLEBOX PLUS DL 125	EN 12050 - 2
SINGLEBOX PLUS / DOUBLEBOX PLUS DLV 115	EN 12050 - 2

sbox-dboxplus_EN-en_a_sc

AUSTRALIAN DISTRIBUTOR



CALL 1300 789 466
When Pump Knowledge Matters
www.kelairpumps.com.au