

MINIBOX Series

3

Prefabricated compact lifting systems designed to collect domestic effluent (excluding toilet waste) where gravity drainage is not possible.

Specifications

85-litre polythene tank

Pump: DOC series (DOC 3 or DOC 7) equipped with a float switch for automatic operation

Power supply: single-phase
50 and 60 Hz

Power: 0.25 kW to 0.55 kW

Complete with: screen and sand filter basin, flexible tube with check valve, three diameter 40 mm outlet flanges

Installation is fast and easy, just connect the pipes and plug it in.

Minibox can be installed on the floor, buried or sunk in concrete (to withstand the weight of vehicles).

Minibox is fitted with a screen and sand filter basin for the collection of water infiltration or runoff, as in the case of a garage ramp.

Applications

Residential effluent (excluding toilet waste), rain water and domestic wastewater.



For a complete list of technical information, consult www.lowara.com

MINIBOX SERIES

Operating characteristics at 50 Hz

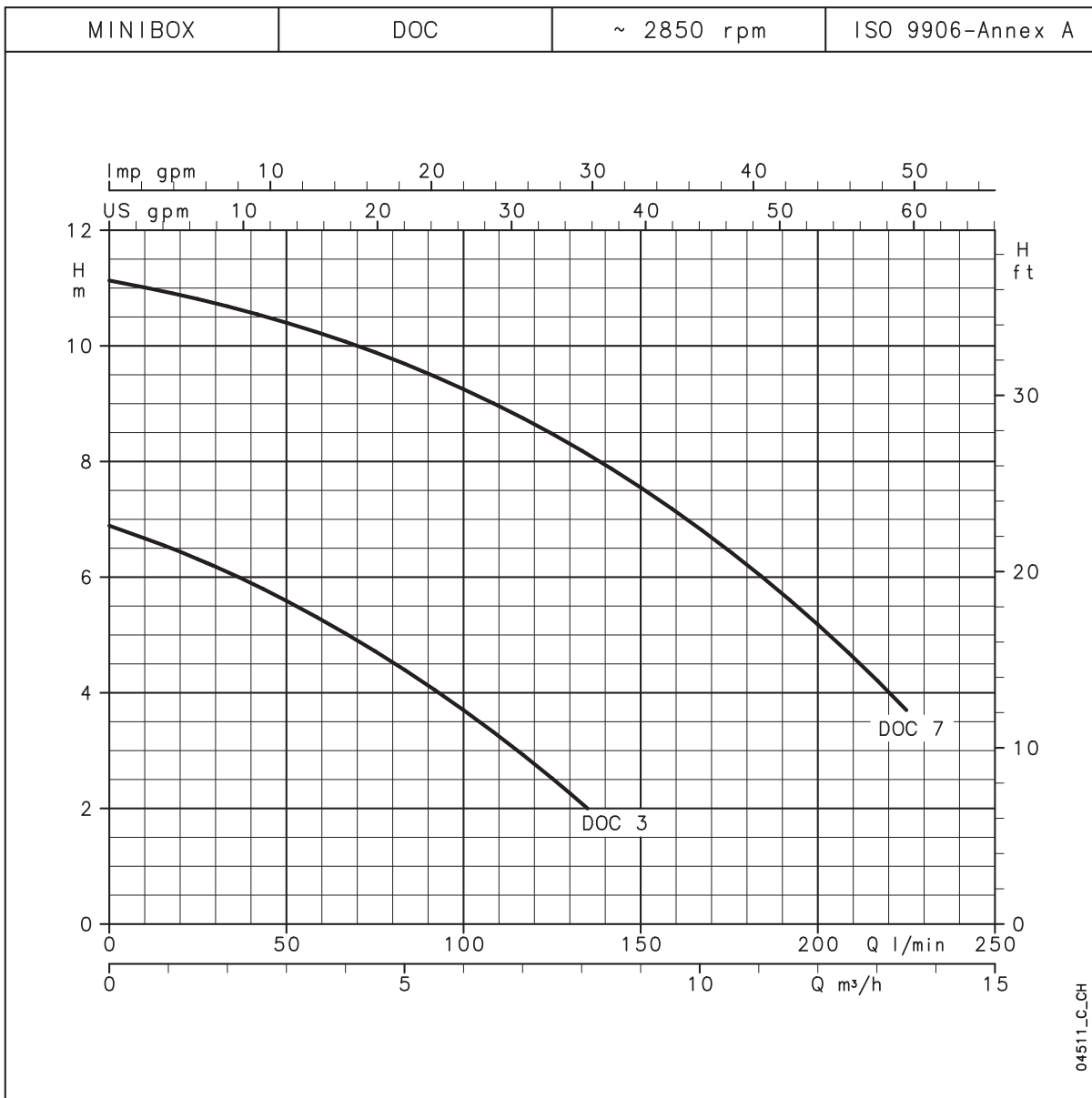

MINIBOX SERIES

Hydraulic performance table

PUMP TYPE	RATED POWER		Q = DELIVERY									
			l/min	0	25	50	75	100	125	135	175	225
			m ³ /h	0	1,5	3	4,5	6	7,5	8,1	10,5	13,5
H = TOTAL HEAD METRES COLUMN OF WATER												
DOC3	0,25	0,33	6,9	6,3	5,6	4,7	3,7	2,5	2,0			
DOC7	0,55	0,75	11,1	10,8	10,4	9,9	9,3	8,5	8,1	6,5	3,7	

These performances (referred to the single pump) are valid for liquids with density $\rho = 1,0 \text{ kg/dm}^3$ and kinematic viscosity $\nu = 1 \text{ mm}^2/\text{s}$.

mbox_doc-2p50_b_th

Electrical data

PUMP TYPE	ABSORBED POWER*		ABSORBED CURRENT*	CAPACITOR	PUMP TYPE	ABSORBED POWER*		ABSORBED CURRENT*	ABSORBED CURRENT*
	SINGLE-PHASE		220-240	F / 450 V		THREE-PHASE		220-240	380-415
	kW		A			kW		A	A
DOC 3	0,31		1,43	6,3	-	-		-	-
DOC 7	0,78		3,47	16	-	-		-	-

*Maximum values within operating range.

mbox_doc-2p50_a_te

MINIBOX SERIES

Dimensions and weights

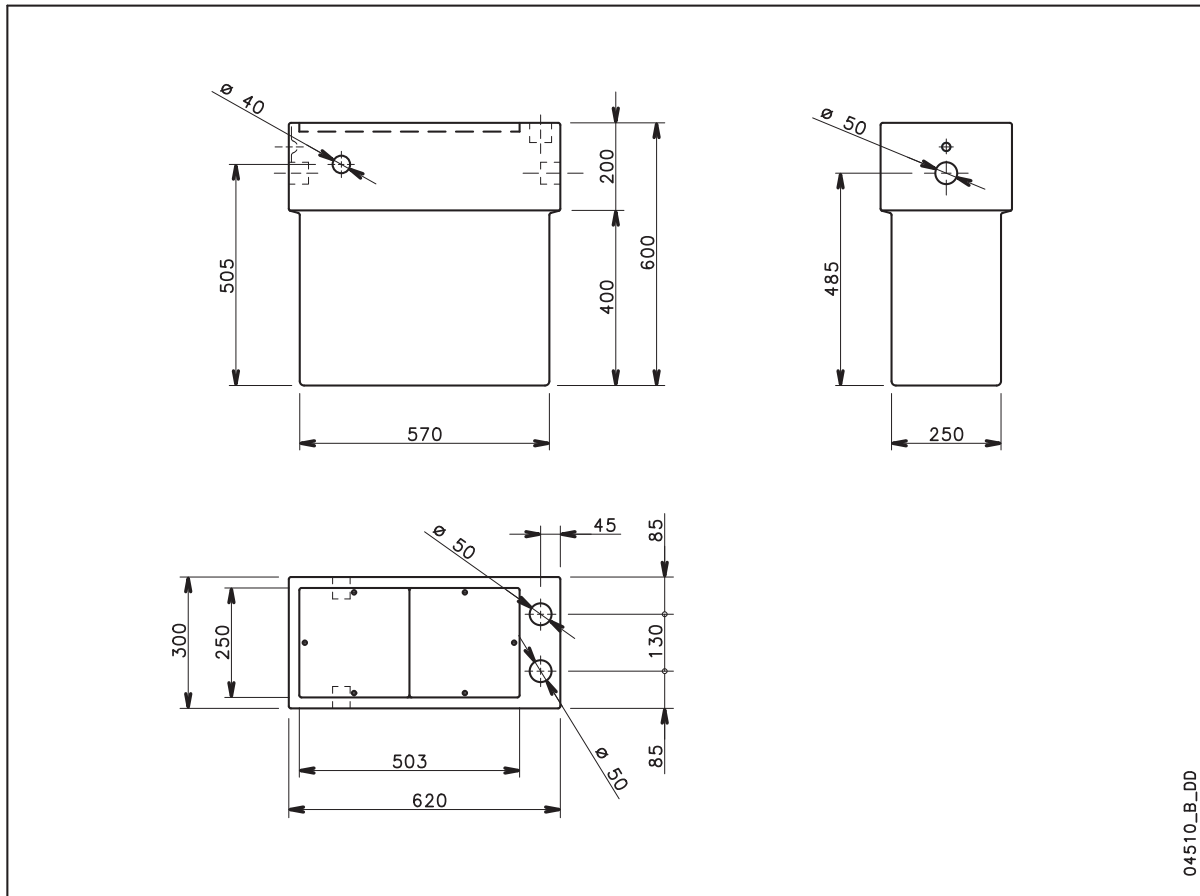

04510_B_DD

AUSTRALIAN DISTRIBUTOR



CALL 1300 789 466
 When Pump Knowledge Matters
www.kelairpumps.com.au