



GAH SERIES SUCTION SHOE TECHNOLOGY

The GAH Series extends the GA Series to high-system pressure applications for an ideal solution for a wide-range of low-flow applications.

The GAH Series is part of the patented suction shoe gear pump design offered exclusively by Micropump. The suction shoe technology offers best in class performance with industry-leading volumetric efficiency for fluid movement.

MAGNETIC DRIVE GEAR PUMP

HIGH-SYSTEM PRESSURE CAPABILITY

Series GAH pumps are designed to withstand system pressures up to 345 bar (5000 psi).

RELIABILITY

GAH Series pumps self-compensate for wear, ensuring near zero slip and a longer pump life. The suction shoe technology delivers even longer reliability with higher differential pressures when compared to cavity style designs.

WIDE TEMPERATURE RANGE

Micropump's GAH Series features the same hydraulic performance from the lowest temperature, even freezing, to the highest temperature allowed by the component materials.



A MOUNT

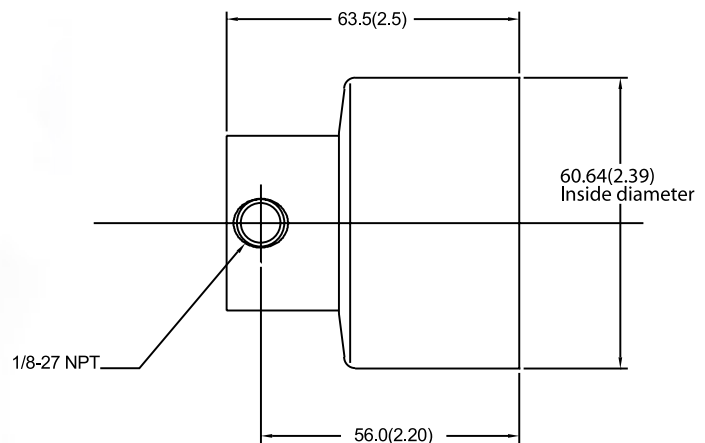

Units: mm(in). Nominal dimensions shown.

PUMP FLOW RANGE

(Based on Constant Speed Curves at 4,000 RPM)

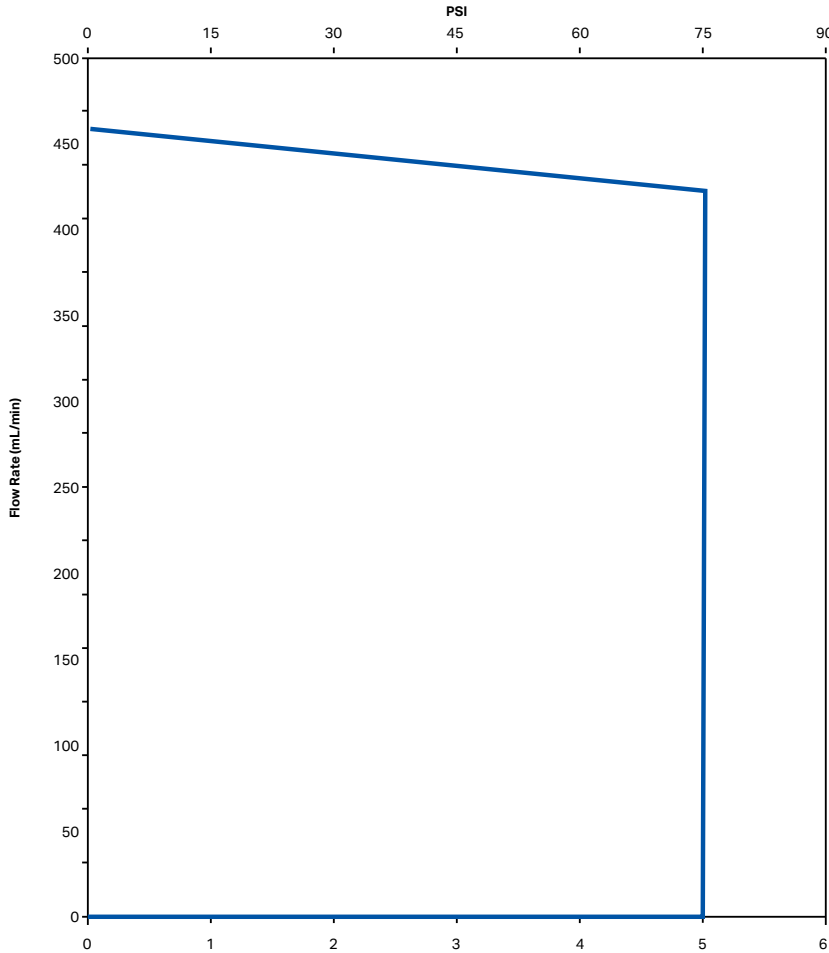

MAGNETIC GEAR PUMP FEATURES

SUCTION SHOE STYLE PUMPS

The suction shoe allows for consistent performance across a wide operating temperature range. The suction shoe pump, unlike any other gear pump on the market, self adjusts on the job for reliable, pulseless flow, and features easier maintenance with less downtime than standard pumps.

SMOOTH PULSELESS DELIVERY

Positive displacement, precision gears provide consistent fluid delivery in continuous processes.

EASY TO SERVICE

Our pumps are easy to service using a Micropump® service kit and simple hand tools.

LEAK FREE DESIGN

The magnetic drive and static o-ring seal(s) keep the fluid securely inside the pump and potential contaminants out.

CHEMICALLY RESISTANT

Chemically inert materials for harsh environments.

PERFORMANCE SUMMARY

FLOW RATE AT 5500 RPM

- 506 mL/min (0.134 US gpm)

DISPLACEMENT

Gear Set	X21	V21	T23
mL/rev	0.017	0.042	0.092
US gal/1000 rev	0.045	0.01	0.02

MAXIMUM RATED DIFFERENTIAL PRESSURE

- 5.2 Bar (75 psi)

MAXIMUM RATED SYSTEM PRESSURE

- 345 Bar (5000 psi)

TEMPERATURE RANGE

- 46 to 177 °C (-50 to 350 °F)

VISCOSITY RANGE

- 0.5 to 1500 cpse

MAXIMUM RECOMMENDED SPEED

- 5500 rpm

PUMP CONSTRUCTION

- Suction shoe style
- Side Port
- Spur gears
- PTFE Seal

WETTED MATERIALS

BASE MATERIAL

- 316 stainless steel
- Alloy 20*
- Titanium*
- Hastalloy C-276*

GEARS

- Carbon Graphite
- PPS*
- PPS-Pin*
- PEEK
- PEEK-Pin*

STATIC SEALS

- PTFE
- EP*
- Viton
- Kalrez*

MAGNETS

DRIVEN

- Ferrite

DRIVING

- SmCo
- Rare earth*

*Denotes customization or materials that may require minimum order quantities.

AUSTRALIAN DISTRIBUTOR



CALL 1300 789 466

When Pump Knowledge Matters
www.kelairpumps.com.au