

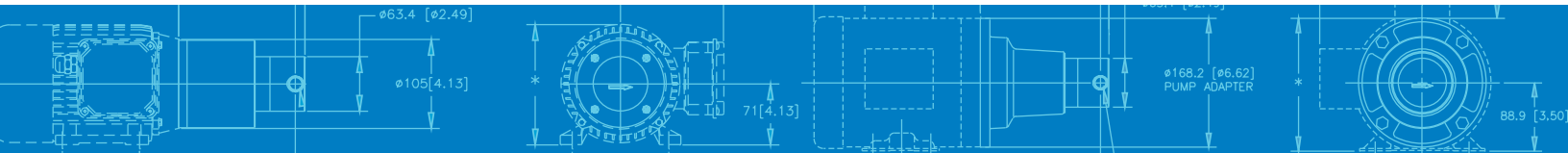

# Series GJ

## MAGNETIC DRIVE GEAR PUMP

Series GJ pumps deliver exceptional pumping performance for any high-precision application. These compact magnetically driven gear pumps feature a cavity style design with no dynamic seals for applications that cannot tolerate leaks. Micropump's Series GJ pumps offer excellent chemical resistance, abrasive fluid pumping, and smooth pulseless fluid delivery. Series GJ pumps are ideal for a wide-range of fluidic applications.



### CAVITY STYLE PUMPS

Cavity style pumps are excellent for wide-ranging inlet and outlet operating conditions, and allow for intermittently pumping in reverse.

### SMALL SIZE

The miniature package size of the Series GJ is easily incorporated into the design of many systems.

### FLUID PATH INTEGRITY

The magnetic drive and static PTFE seals keep the fluid securely inside the pump and potential contaminants out.

### SMOOTH PULSELESS DELIVERY

Positive displacement, precision gears provide consistent fluid delivery in continuous processes.

### CHEMICALLY RESISTANT

Series GJ has a long-life in aggressive environments.

### EASY TO SERVICE

Series GJ pumps are easy to service using a Micropump service kit and simple hand tools.

### WIDE RANGE OF CONFIGURATIONS

Micropump's designs offer a wide range of configurations to meet your more challenging requirements including:

- ▶ Three standard gear sizes
- ▶ Multiple gear and body materials
- ▶ Optional internal bypass
- ▶ Optional high-torque magnets
- ▶ NEMA, IEC, EagleDrive™, and Micropump drive mounts

# PUMP PERFORMANCE

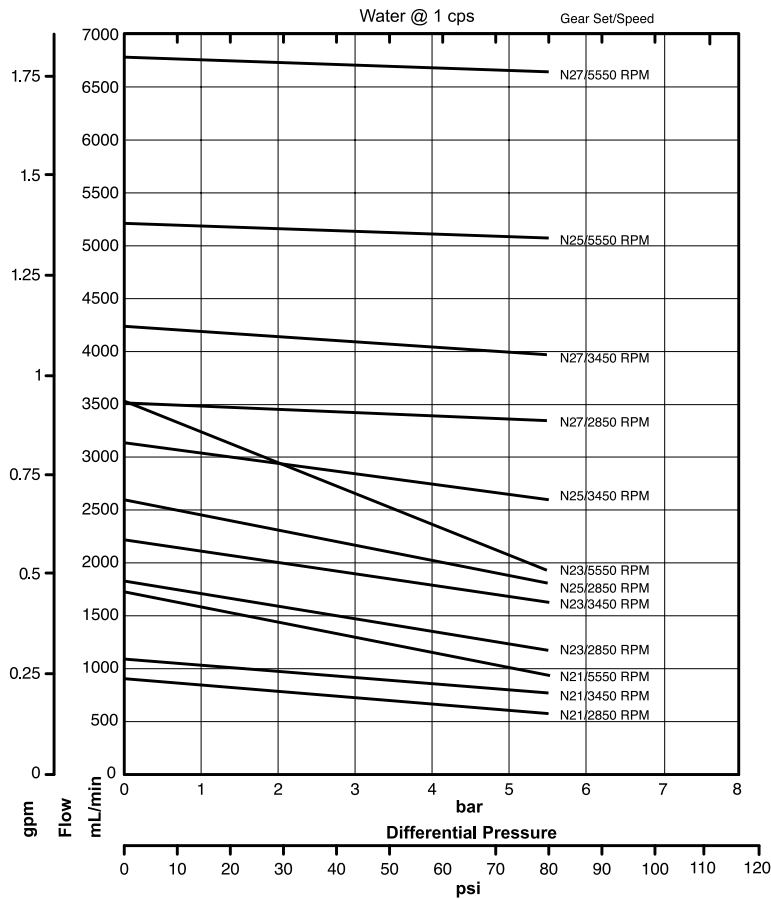

## PERFORMANCE SUMMARY

### FLOW RATE AT 5500 RPM

- ▶ 6.8 L/min (1.8 US gpm)

### DISPLACEMENT

- ▶ Gear Set                    N21    N23    N25    N27
- ▶ mL/rev                    0.316   0.64   0.91
- 1.23
- ▶ US gal/1000 rev        0.08   0.17   0.24
- 0.32

### MAXIMUM RATED DIFFERENTIAL PRESSURE

- ▶ 5.6 Bar (80 psi)

### MAXIMUM RATED SYSTEM PRESSURE

- ▶ 21 Bar (300 psi)

### TEMPERATURE RANGE

- ▶ -46 to 121 °C (-50 to 250 °F)

### VISCOSITY RANGE

- ▶ 0.5 to 1500 cps

### MAXIMUM RECOMMENDED SPEED

- ▶ 5500 rpm

## PUMP CONSTRUCTION

- ▶ Magnetic drive gear pump
- ▶ Cavity style
- ▶ Two helical, shafted gears
- ▶ Sleeve bushings
- ▶ PTFE bevel or o-ring seal

## WETTED MATERIALS

### BASE MATERIAL

- ▶ 316 stainless steel    ▶ Alloy 276
- ▶ Titanium                    ▶ Alloy 20

### GEARS

- ▶ PEEK
- ▶ PPS
- ▶ PTFE

### STATIC SEALS

- ▶ PTFE

## MAGNETS

### DRIVEN AND DRIVING

- ▶ Ferrite
- ▶ Electromagnetic
- ▶ Rare earth

## PRODUCT ENHANCEMENTS

- ▶ Internal Bypass
- ▶ Deck Ports

## DIMENSIONS

### A MOUNT

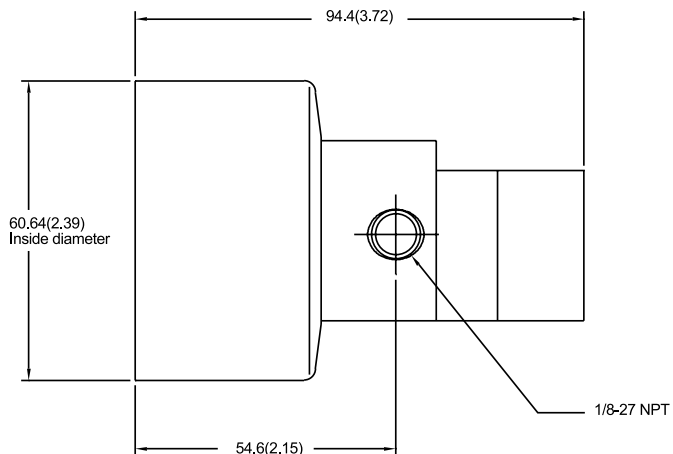

Units: mm(in). Nominal dimensions shown.

AUSTRALIAN DISTRIBUTOR

**MICROPUMP®**



CALL 1300 789 466  
 When Pump Knowledge Matters  
[www.kelairpumps.com.au](http://www.kelairpumps.com.au)