

# HS SERIES SUBMERSIBLE SLUDGE PUMP



## POWERFUL ENOUGH TO HANDLE ANY TOUGH JOB

The submersible sludge pump is designed and manufactured to be suitable for dredging and transporting sand, ballast, gravel, sludge or slurry contained in water in demanding conditions such as dams, power stations, harbour projects or funneling works etc.

Fitted with an Agitator these models are designed to stir up mud and sand at the bottom and then discharge the water, mud and sand in suspension more effectively.



### CUT-AWAY SECTION

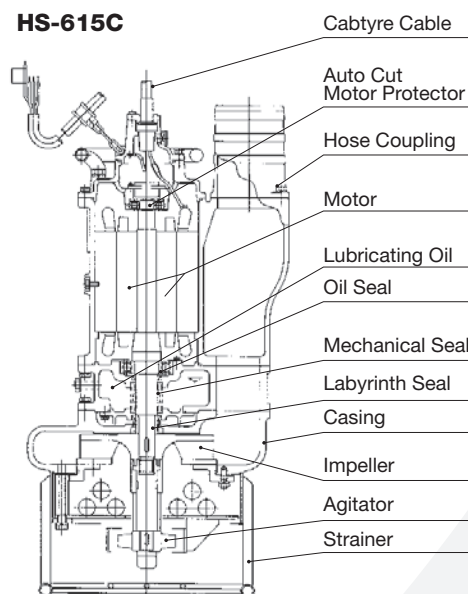

### FEATURES

- The internal design of these models ensures excellent suction capability. The hydraulically designed impeller of wear resistant high chrome alloy ensures clog free operation. The flow passage is designed to pass from 10 to 20% of sand or mud in the water. The HS series is capable of pumping solids from 18mm up to 35mm in diameter.
- The strong and compact design makes these models exceptionally functional and economical as well as being light weight for easy handling in confined quarters.
- All components are subjected to a rigorous system of quality control, impellers are carefully balanced and the pumps feature excellent resistance to abrasive particles in dirty water. Motor compartment sealing is by Double Mechanical Seals (with hard faces) in an oil bath. This is further enhanced by using a labyrinth seal and pressure relief arrangement which ensures long seal life.
- Maximum interchangeability of parts with other models simplifies maintenance and reduces costs.
- Built-in motor protector (Auto-Cut) guards the motor against electrical and mechanical problems to ensure safe operation of the unit.
- Easy installation and operation as there is no suction hose, foot valve or priming required because the pump is totally submerged.

# SUBMERSIBLE SLUDGE PUMP HS SERIES

## APPLICATIONS

Dredging and transporting sand, ballast, gravel, sludge or slurry contained in water, for heavy duty conditions such as in dams, power stations, harbour projects or funnelling works etc.



## PERFORMANCE CURVES

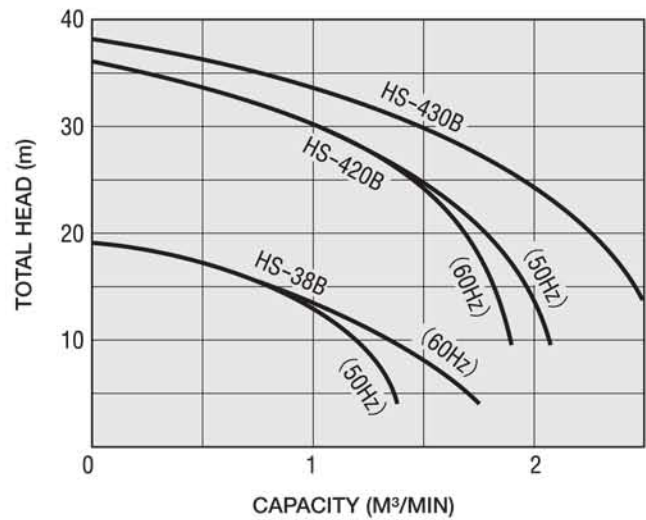
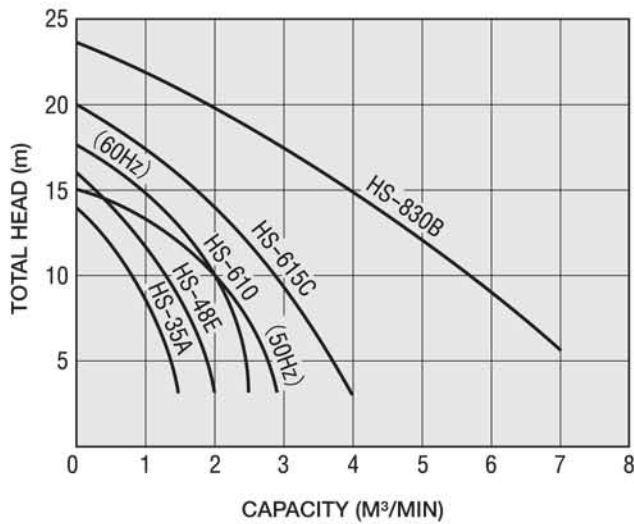

## SPECIFICATIONS

MODEL	DISCHARGE DIA mm	HEAD m	CAPACITY m³/min	MOTOR kW	DIMENSIONS		WEIGHT kg	SOLIDS MAX DIA mm
					MAX DIA mm	HEIGHT mm		
<b>HS-35A</b>	80	10	0.8	3.7	410	810	110	22
<b>HS-38B</b>	80	15	0.8	5.5	415/410	815/810	119	22
<b>HS-48E</b>	100	10	1.3	5.5	410	810	119	25
<b>HS-610</b>	150	10	2	7.5	530	840	200	35
<b>HS-615C</b>	150	14	2	11	555	1,025	240	35
<b>HS-420B</b>	100	27	1.3	15	530	1,300	350	18
<b>HS-430B</b>	100	30	1.5	22	540	1,350	420	18
<b>HS-830B</b>	200	15	4	22	630	1,180	355	40

AUSTRALIAN DISTRIBUTOR



CALL 1300 789 466

When Pump Knowledge Matters  
www.kelairpumps.com.au