

U SERIES  
HIGH CAPACITY



# SUPER POWERFUL, EFFICIENT, DEPENDABLE!

These models are especially designed to be used for major dewatering jobs, particularly when bigger Volume of water is required to be handled.

They have extremely high capacity and are excellent in heavy-duty oriented conditions.



## CUT-AWAY SECTION

U-4158A

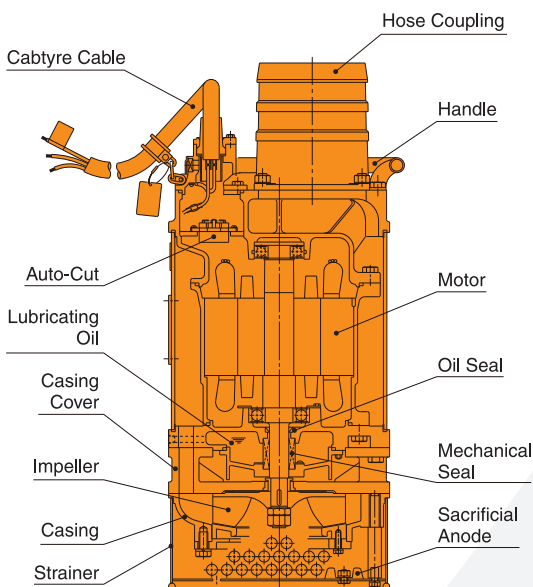

## MOTOR PROTECTION

An INFILTRATIVE WATER DETECTOR (WD) and MINIATURE THERMAL PROTECTOR (MTP) are incorporated in the pump body to protect the motor from electrical and mechanical failures. Combined with the operating panel (at extra cost) equipped with an ELECTROMAGNETIC CONTACTOR (MC), INFILTRATIVE WATER DETECTOR RELAY SET (WD-X) and THERMAL RELAY (THR) the pump provides faultless and safety conscience motor protection. If water infiltrates the motor housing or the temperature in the motor winding rises to the set maximum the WD, fitted immediately beneath the motor compartment, or the MTP activates the MC via the WD-X or THR to cut the electricity supply to the motor.

U-4158A, U-4208 and U-4308 have built-in "Auto-Cut" auto-reset type thermal protection and are equipped to guard the motor against potential electrical and thermal failure. U-4306D, U-4310B and U-4308 are equipped with "Auto-Cut" for 200-220V only.

## MOTOR

The motors are designed to provide high motor efficiency and torque. Six pole motors are used for U-65014B and four pole motors are used for other models to meet the required high capacity.

## SHAFT SEAL

Double Mechanical Seals cooled and lubricated in an oil bath are provided to ensure reliable sealing and stable service at demanding dewatering sites.

## IMPELLER AND CASING

The open type impeller made of hardened High Chrome Alloy is housed in a heavy gauge body and gives high efficiency pump performance. When combined with assorted casing materials the pump provides excellent wear resistance in water containing abrasive particles.

# DEWATERING PUMP HIGH CAPACITY SERIES

## DIMENSIONS

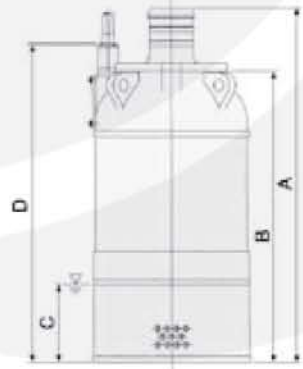
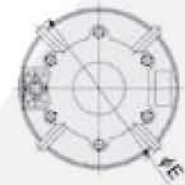

C : Minimum Water Level

## APPLICATIONS

Sump Drainage, Pit, Quarry, Mining, Cellar,  
Dam, Harbour & Agricultural Irrigation Projects,  
Tunnel, Caisson Dewatering, Reclamation Operation  
Power Station Construction, Waste, Storm or Emergency Water Removal,  
Contractors & Rental Companies etc.

## PERFORMANCE CURVES

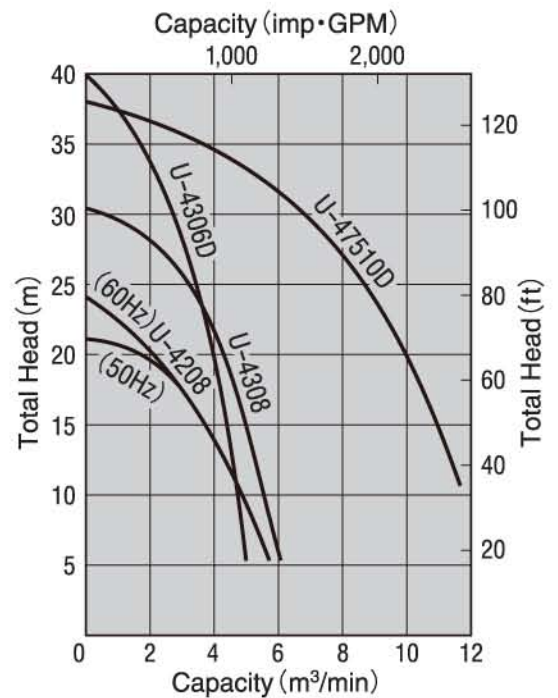
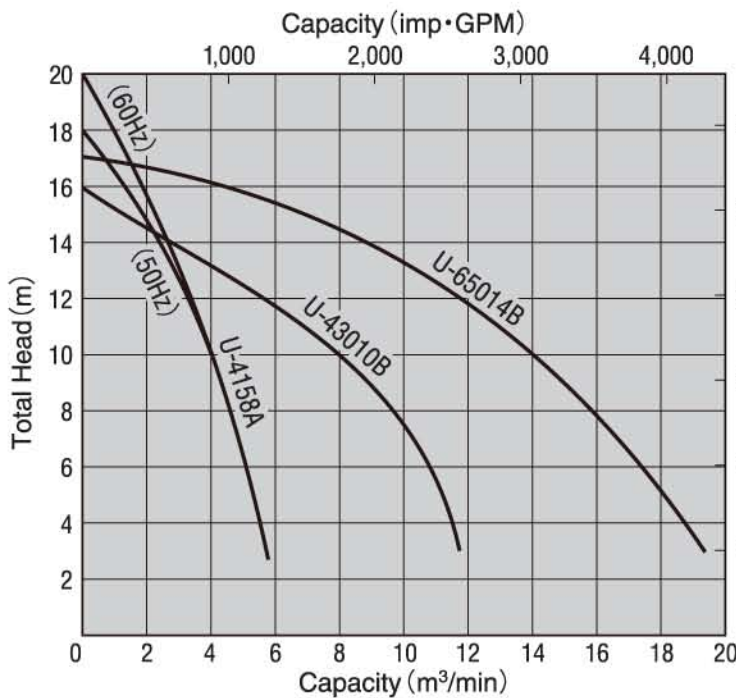

## SPECIFICATIONS

Models	Discharge Dia.		Motor Output		Head		Capacity		Dimensions (mm)					Cable Length		Weight (w/o Cable)	
	mm	in	kW	HP	m	ft	m³/min	imp·GPM	A	B	C	D	E	m	ft	kg	lbs
U-4158A	200	8	11	15	10	33	4	880	940	—	250	805	455	10	33	177	390
U-4208	200	8	15	20	14	46	4	880	975	—	250	805	455	10	33	227 *(212)	501 *(467)
U-4306D	150	6	22	30	33	108	2	440	1,130	—	250	1,015	540	10	33	365	805
U-4308	200	8	22	30	22 15	66 45	4 5	880 1,100	1,158	—	250	1,015	540	10	33	440	968
U-43010B	250	10	22	30	10	33	8	1,760	—	1,000	350	1,085	540	10	33	355	783
U-65014B	350	14	37	50	10	33	14	3,080	—	1,310	400	1,475	670	10	33	700	1,544
U-47510D	250	10	55	75	27	89	8	1,760	—	1,270	350	1,435	670	20	66	730	1,610

Motors bigger than 50HP are star-delta starting. Other specific applications available on request. \*Figures in parentheses refer at 60Hz.

AUSTRALIAN DISTRIBUTOR



CALL 1300 789 466

When Pump Knowledge Matters  
www.kelairpumps.com.au