

2" NON-METALLIC FLAP VALVE

SANDPIPER
A WARREN RUPP, INC. BRAND



The new 2" Heavy Duty Non-Metallic Flap Valve Pump has been designed to solve the most common problems in mine dewatering, sump, and chemical transfer applications.



Solids Range
Up to 1.8" (46mm)



Superior Dry Prime
Up to 20' (6.1 m) of water



Flap Check Valves
Performance & solids handling



Bottom Discharge
Gravity assist is ideal for pumping liquids with settling solids



ESADS+Plus Air Valve
Externally Serviceable Air Distribution System



Lowest air consumption in its class
Less than Less than 65 SCFM at Max pump flow



Lightweight & Portable
At 53 lbs (24 kg) it is safely and easily transported



All Bolted Construction
Leak free design



IPEX
FLUID & METERING



SANDPIPERPUMP.COM/HDF2NM

REDEFINING THE FLAP VALVE PUMP

YOUR MINING, GENERAL INDUSTRIAL AND CHEMICAL SOLUTION

The robust, yet lightweight design allows for ease of maintenance and movement, and is ideal for handling solids and corrosive fluids. This unique pump has been engineered to fully function in any position, includes lifting handles and hanging points, and has durable mounting feet. This is an ideal solution for numerous applications.

Lightweight & Durable
The non-metallic, lightweight design makes it easily portable at 53 lbs (24 kg)

Reliability Guarantee
Strongest diaphragm connecting rod in the industry is guaranteed to not bend or yield in operation

Rugged Design
Stainless steel seats prevent abrasion when pumping solids laden fluids

Optimum Solids Handling
Hinge pads exert positive pressure on the flaps, allowing the pump to operate in virtually any position; they help deliver superior suction lift and flow rates

Long Life
A proven diaphragm design in conjunction with exclusive wear pads reduce plate abrasion, delivering extended life

Purpose Built Base
Stainless steel, corrosion resistant mounting feet allow for pump stability while reducing potential housing damage

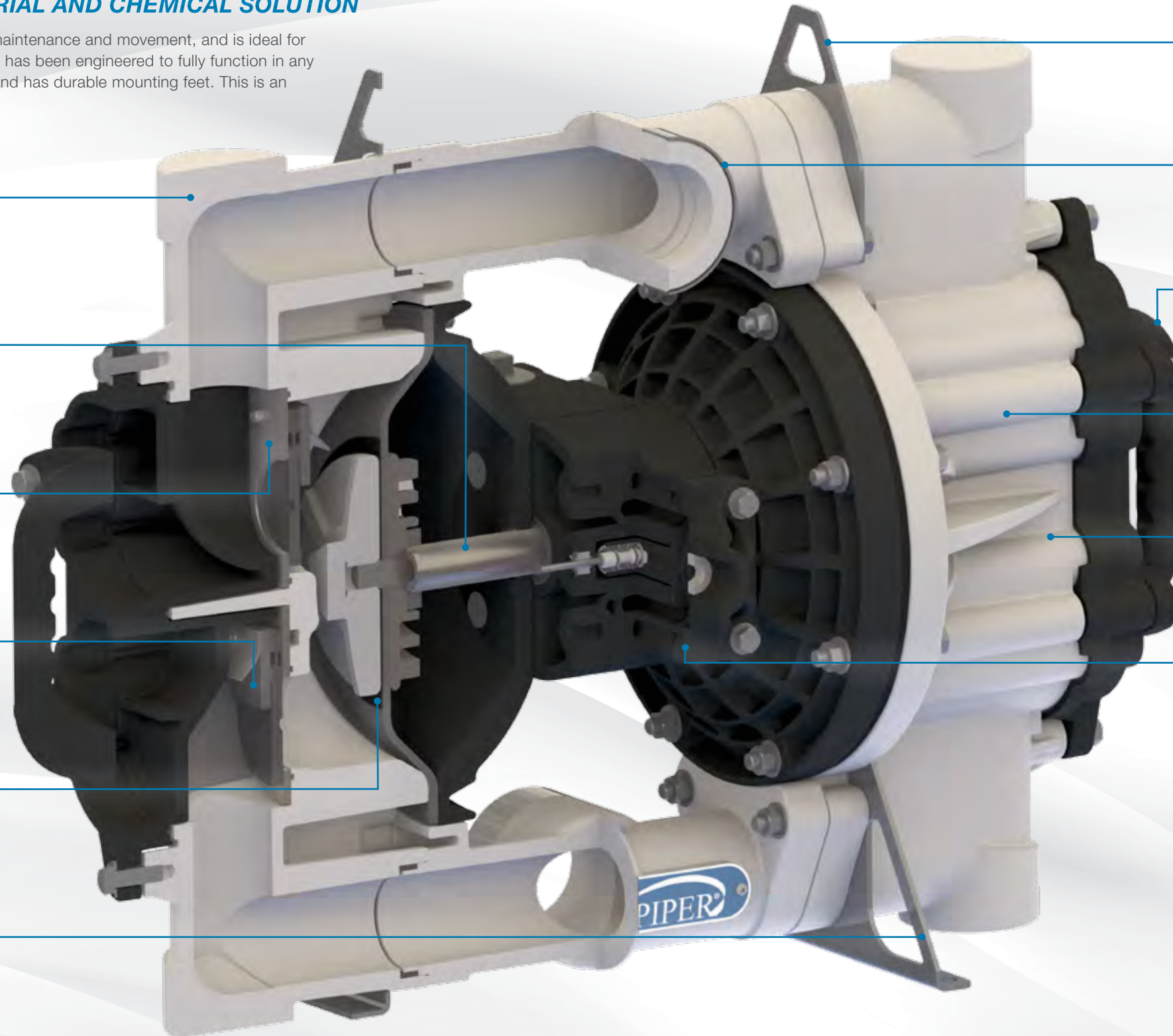

Industrial Mounting Capabilities
Addition of stainless steel hanging points located on the manifold allow for multiple mounting options

Strong Manifold Connections
Stainless steel reinforcing rings help protect the threaded manifold connections from being damaged from overtightening and excessive piping or hose stress

Ergonomic Handle
Lifting handles come standard, allowing for easy pump transport; handles can be rotated 90 degrees for proper ergonomics, depending on desired use

Unsurpassed Performance
Industry leading flow rates, suction lift, air efficiency and displacement per stroke

Versatile Design
This pump will function in any position, including uneven surfaces

Simple Maintenance
With our signature ESADS+Plus (Externally Serviceable Air Distribution System) air valve design and externally serviceable flap valve modules, in-field service is quick and easy, saving you from unnecessary downtime



Visit SANDPIPERPUMP.COM/ESADSVideos to see how easy the ESADS air valve makes maintaining the 2" Non-Metallic Flap Valve.

PERFORMANCE & DIMENSIONS

Max Capacity

- 150 GPM (567 L)

Displacement Per Stroke

- .50 Gal (1.9 L)

Max Discharge Pressure

- 100 PSI (7.0 BAR)

Pipe Size

- 2" Female NPT / BSPT

Max Solids Handling

- 1.8" (46mm)

Air End/Wet End

- Polypropylene
- Stainless Steel Seats (Wet End Only)

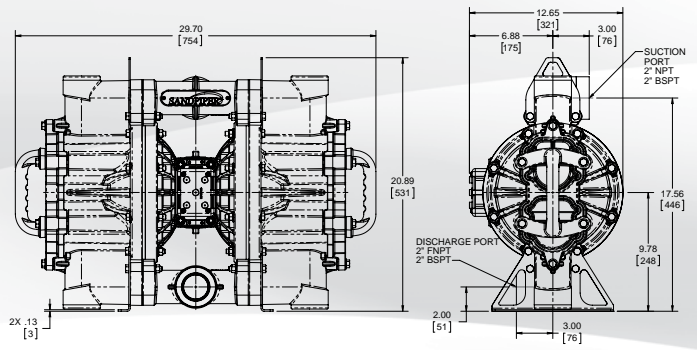
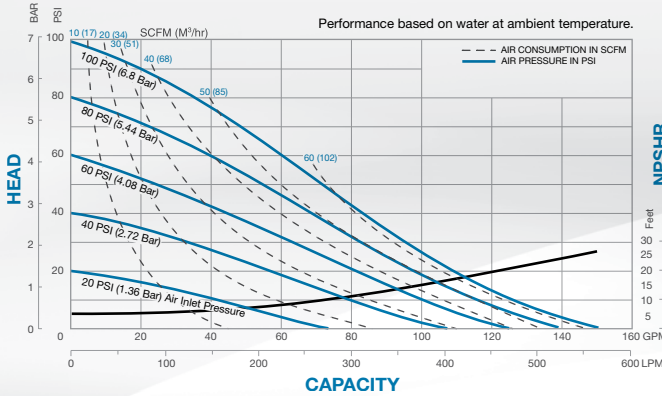

EASE OF MAINTENANCE

To help increase productivity and reduce downtime, the 2" Non-Metallic Flap Valve Pump was engineered with ease of maintenance in mind.

QUICK ACCESS TO SERVICEABLE COMPONENTS

1. Remove Clean-Out Cap

By simply removing six bolts securing the clean-out cap in place, it allows access to clear simple clogs without disassembling the entire pump

2. Modular Check Valve Access

With the clean-out cap removed, the flap valves can be inspected and / or replaced as needed; four bolts hold the modular flap valves in place for quick maintenance and repair

3. ESADS+Plus

Proven air distribution system allows for maintenance and / or repair of both pilot valve and air valve components without removing the pump from service

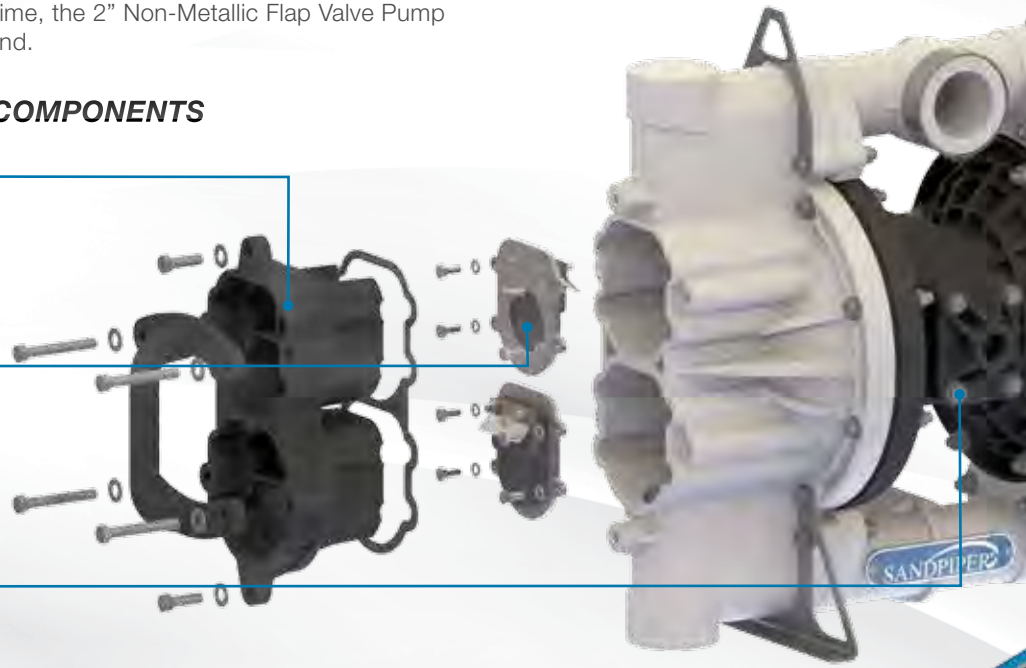

Warren Rupp, Inc.
A Unit of IDEX Corporation
800 North Main Street
Mansfield, OH 44902 USA



Phone: 419.524.8388
Fax: 419.522.7867
SANDPIPERPUMP.COM



Contact Your Local Distributor to Place Your Order:

©Copyright 2015 Warren Rupp, Inc. All Rights Reserved.

spnmflap_bro-rev0315