

GET A PUMP THAT WON'T FREEZE UP!

Viking Pump's stainless steel 4197-SEP Series™ cryogenic pumps are made for the cold! With a low temperature rating of -70°C, these pumps are made to meet the pressures and temperatures of your cold ethanol extraction needs.

FEATURES

- Superior self-priming capabilities
- Low temperature mechanical seal
- Quiet pulsation-free flow
- Designed for continuous or intermittent duty cycle
- Assembled and tested with food grade liquids
- Reliable, steady flow regardless of changes in pressure or viscosity
- Electric motor driven and VFD compatible



Sealed anti-friction bearings eliminate the need for relubrication

Behind the rotor seal, so shaft and bearings not exposed to process fluid

ANSI flanges easily convert to tri-clamp

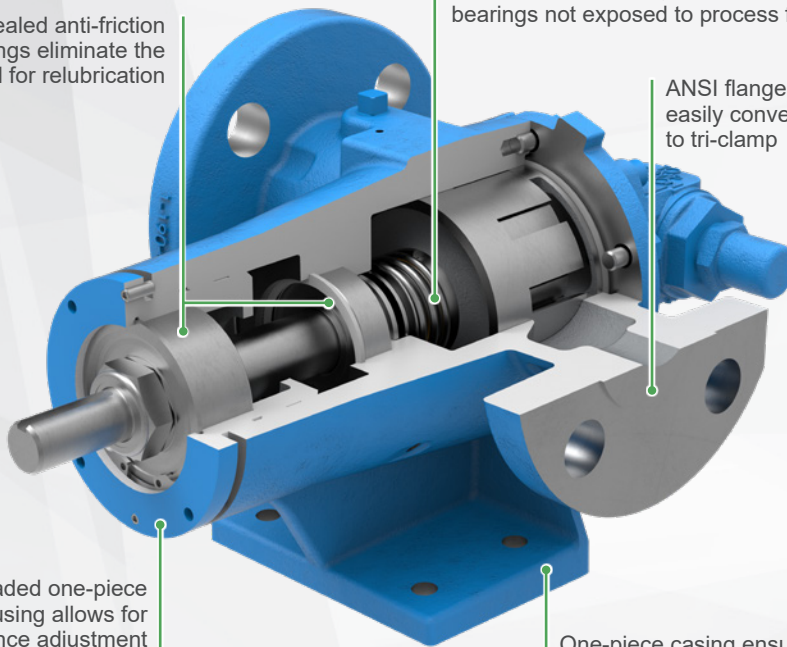

Threaded one-piece bearing housing allows for end clearance adjustment

One-piece casing ensures alignment for maximum bearing and seal life

PERFORMANCE

Model	Standard Class	Nominal Flow		Max. Differential Pressure	Temperature Range		Shipping Weight
	150 Flanged Ports	GPM	RPM		°F	°C	
GG4197-SEP1	1"	10	1750	200	-95 to +225	-70 to +105	20
HJ4197-SEP1	1.5"	20	1750	200	-95 to +225	-70 to +105	50
HL4197-SEP1	1.5"	30	1750	200	-95 to +225	-70 to +105	50
AS4197-SEP1	3"	35	1150	200	-95 to +225	-70 to +105	115
AK4197-SEP1	3"	50	1150	200	-95 to +225	-70 to +105	115
AL4197-SEP1	3"	75	1150	200	-95 to +225	-70 to +105	120

NOTE: Please contact Viking Pump for performance curves specific to your application.

PUMP RATINGS OF
-70°C
& UP TO
200 PSI

GET WHAT MATTERS MOST



Low Temperature Capabilities



Hemp Market Proven



Rapid Response Time



Short Lead Time



Local Support

CURVES

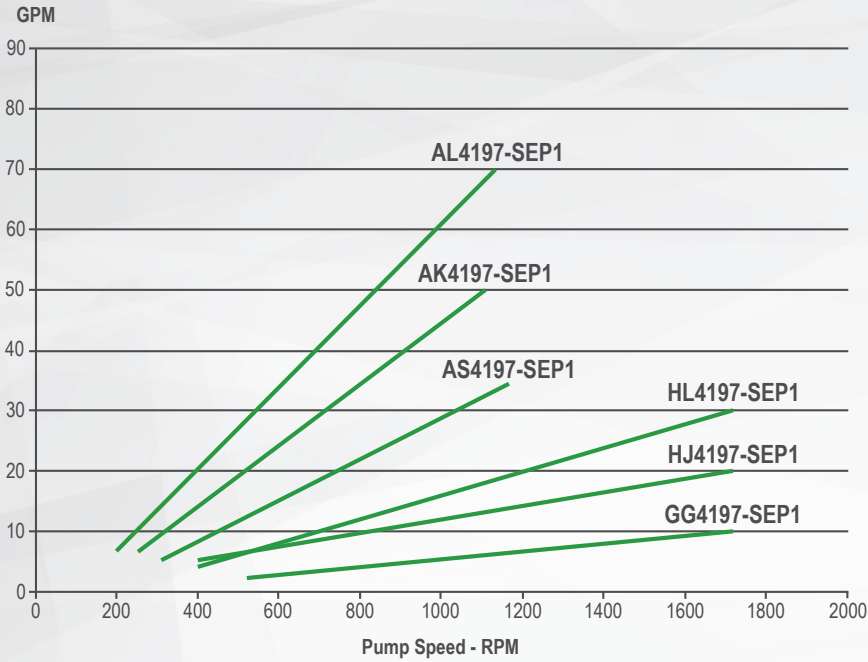

DIMENSIONS

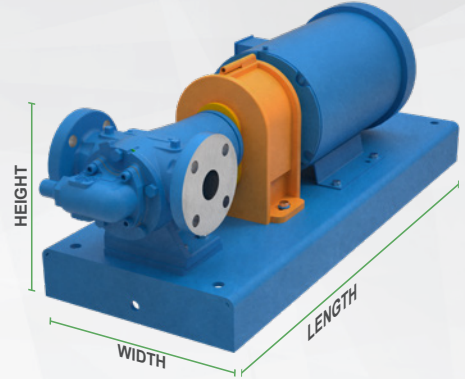

HL4197-SEP1 pump with motor mounted on base

Model	Motor Frame Size	Length (inches)	Width (inches)	Height (inches)
GG4197-SEP1	143/5T	25"	10"	9"
HJ4197-SEP1	143/5T	26"	10"	12"
HL4197-SEP1	143/5T	26"	10"	12"
AS4197-SEP1	182/4T	31"	12"	16"
AK4197-SEP1	213/5T	36"	12"	16"
AL4197-SEP1	213/5T	36"	12"	16"

VERTICALLY INTEGRATED PRODUCTION PROCESS:

Viking Pump operates two foundries, a 250,000+ sq. ft. machining, assembly and testing center, and an extensive product engineering and testing lab in its world headquarters in Cedar Falls, Iowa, USA. This level of vertical integration ensures maximum quality, ability to satisfy special needs, and to meet project schedules.

<p>1 MELT & MOLD</p>	<p>2 SHAKEOUT, CHIP & GRIND</p>	<p>3 MACHINING</p>	<p>4 ASSEMBLY</p>	<p>5 TESTING</p>
<p>IRON FOUNDRY</p>	<p>ALLOYS FOUNDRY</p>	<p>MACHINE SHOP</p>		<p>WORLD HQ - USA</p>



VIKING PUMP, INC.
 A Unit of IDEX Corporation
 406 State Street
 Cedar Falls, Iowa 50613 U.S.A.
vikingpump.com



Contact Your Stocking Distributor Today

Distributed By:

AUSTRALIAN DISTRIBUTOR



CALL 1300 789 466

When Pump Knowledge Matters
www.kelairpumps.com.au