

# O-PRO™ SEAL TECHNOLOGY

## O-PRO™ SEAL TECHNOLOGY – SIMPLE, PROVEN & RELIABLE

Viking Pump is the leader in internal gear innovation and the latest development is the patented O-Pro™ Seal technology. O-Pro™ Seals utilize a series of O-rings to create a robust seal and lubrication chamber, all in one. O-Pro™ Barrier seal functions as both a seal and bracket bushing; while the O-Pro™ Guard seal is a simple retrofit option.

### O-PRO™ BARRIER SEAL

#### HOW IT WORKS:

O-Pro™ Barrier seal replaces packing or mechanical seal by occupying the internal bracket cavity with a machined seal gland, utilizing O-rings to seal externally on the bracket and internally on the shaft. A combination of O-rings and lubricating fluid provide a robust seal preventing process fluid from leaking out of the pump. O-Pro™ Barrier design also contains lubrication between the shaft and bushing reducing wear.

*The O-Pro™ Barrier seal, made of hardened cast iron, combines a bracket bushing and seal gland, with double O-ring seals, to stop process fluids from entering the bracket and eventually leaking from the pump.*

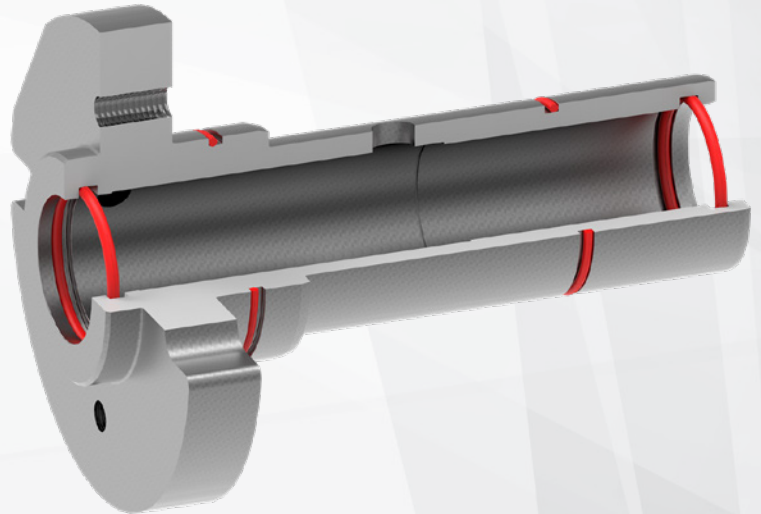

### O-PRO™ GUARD SEAL

#### HOW IT WORKS:

O-Pro™ Guard seal replaces packing or mechanical seal by sealing between the bracket, sleeve & shaft surfaces with a series of O-rings. The series of O-rings and lubrication provide a robust seal for many applications. The stainless steel construction utilizes a sleeve that is secured to the shaft to address any shaft wear concerns to ensure superior performance.

*The O-Pro™ Guard seal is a compact design for an easy retrofit answer for a leaking pump. Stainless steel construction provides compatibility in many applications.*

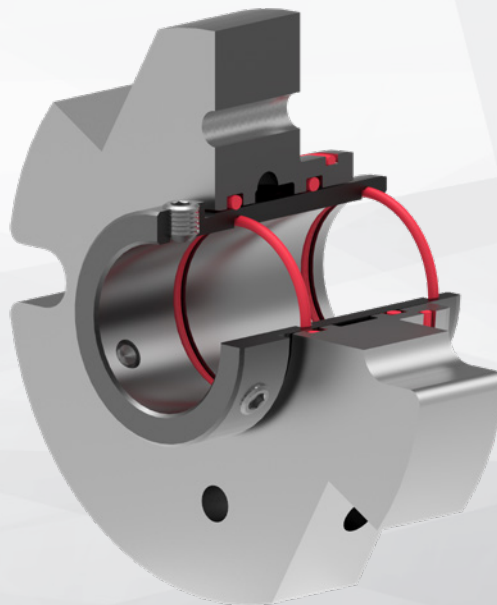

AUSTRALIAN DISTRIBUTOR

**VIKING PUMP®**



CALL 1300 789 466  
When Pump Knowledge Matters  
[www.kelairpumps.com.au](http://www.kelairpumps.com.au)

## O-PRO™ BARRIER

O-Rings trap clean lubrication **inside** the seal to reduce wear between the shaft and the bracket bushing, keeping all parts in optimal condition.

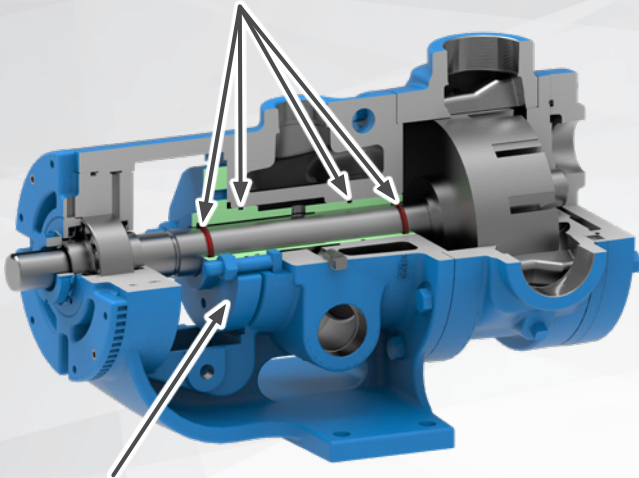

Back-pull-out bracket bushing for ease of seal replacement, jackscrews available for removal

## O-PRO™ GUARD

Existing bracket bushing is utilized; packing is removed, and seal is installed in place of packing gland.

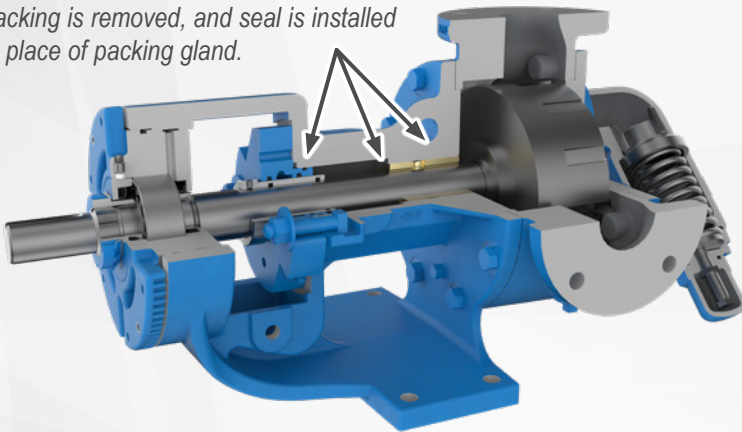

## MAINTENANCE

All O-Pro™ seals should be re-greased every 500 hours. The relief fitting enables visual inspection of the grease to ensure no process fluid leaks. Periodic re-tensioning is not required. O-Pro™ seals may be removed with the pump in place to replace O-rings, by removing the bearing housing. Spacer couplings are required to provide enough room to remove the O-Pro™ Barrier completely. Spacer couplings are not needed if the rotor/shaft is removed from the head end of the pump, which also makes it easier to re-install the O-Pro™ Barrier and then re-install the rotor/shaft.

## RETROFITABILITY

The following existing Viking pump series may be retrofitted to utilize the O-Pro™ seals:

124A Series™	127A Series™
4124A Series™	4127A Series™
224A Series™	227A Series™
4224A Series™	4227A Series™
324A Series™	327A Series™
4324A Series™	4327A Series™

Kits are available with all parts needed for conversion. If shafts are worn, new rotor/shafts may be required for conversion to ensure sealing. Q and QS size brackets may require modification or replacement, if using the O-Pro™ Barrier, which is not included in the kits.

## TYPICAL APPLICATIONS

Inks, paints, molasses, edible oils, corn syrup, honey, lube oil, grease, asphalt, wax, resins, starch, fats, isocyanates, adhesives and many more!

## KIT PART NUMBERS

Seal Type	H-HL	K-KK	L-LL	LS	Q-QS	M	N	R-RS
O-Pro™ Barrier	3-464-SEAL-K450	3-464-SEAL-K451	3-464-SEAL-(K452: 1 7/16")	3-464-SEAL-K453	3-464-SEAL-K454	N/A	3-464-SEAL-K471	3-464-SEAL-K472
O-Pro™ Guard	3-464-SEAL-K482	3-464-SEAL-K483	3-464-SEAL-K484	3-464-SEAL-K485	3-464-SEAL-K486	3-464-SEAL-K487	3-464-SEAL-K488	3-464-SEAL-K489

## MAXIMUM RPM

Seal Type	H	HL	K	KK	L	LQ	LL	LS	Q	QS	N	R	RS
O-Pro™ Barrier	1000	1000	780	780	640	640	520	640	470	470	330	260	260
O-Pro™ Guard	760	760	520	520	N/A	520	520	520	350	350	280	225	225