



KelairPumps

CALL 1300 789 466

SANDPIPER PB 1/4 Non-Metallic

WHEN PUMP
KNOWLEDGE
MATTERS

Is this the quietest and most flexible compact AODD?

Quiet, flexible and
ultra-compact design

Externally servicable
air valve

Non-stalling, non-
icing & lube free air
valve system

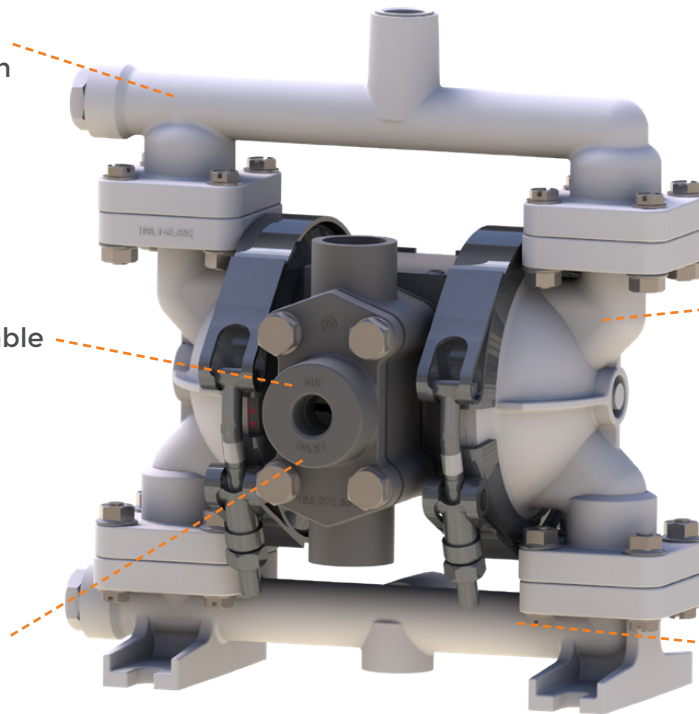

SANDPIPER
A WARREN RUPP, INC. BRAND

5-year
warranty

New single piece
multi-port manifold
replacing old 3-piece
design

The SANDPIPER PB 1/4" air-operated double-diaphragm (AODD) pump is engineered with original manufacturers (OEMs) in mind and provides tremendous system flexibility.

As one of the quietest and most flexible AODD pumps in the compact class and featuring a patented air valve system, this pump provides non-stalling, non-icing, lube-free operation for years of dependable service.

The suction and discharge manifolds have multiple porting options.

Available in polypropylene, conductive acetal and PVDF (Kynar) materials of construction, this small, yet powerful pump is ideally suited for dispensing inks, coatings, paints, adhesives, oils and other chemicals.

FEATURES & BENEFITS

- Ultra-compact, efficient lightweight design
- Durable construction for reliability
- Abrasion resistance (low-friction surface)
- Externally serviceable main air valve
- Flexible mounting and porting options
- Horizontal, vertical and end suction

KELAIR PUMPS AUSTRALIA - 1300 789 466

When Pump Knowledge Matters





| | SANDPIPER | WILDEN | GRACO |
|-------------------------------------|----------------------|-------------|-----------|
| Model | PB ¼ | P .025 | 205 |
| Fluid Connections | | | |
| Inlet (NPT) | ¼”F Int & ½”M Ext | ¼”F Int | ¼”F Int |
| Outlet (NPT) | ¼”F Int & ½”M Ext | ¼”F Int | ¼”F Int |
| Inlet/Outlet Port Positioning | Centre & Side Option | Centre only | Side only |
| Maximum Flow at 100psi (LPM) | | | |
| TPE & PTFE Diaphragms | 19 | 18.1* | 18.9 |
| Displacement per stroke (litres) | 0.04 | 0.04 | 0.038 |
| Maximum Air Consumption (CFM) | 6 | >5 | 9 |
| Strokes required for 18LPM | 450 | 450 | 474 |
| Maximum Solids Size (mm) | 1 | 0.4 | 1.5 |
| Dry Weight (kg) | 1.8 | 1.4 | 1.1 |
| Warranty Period | 5 Years | 5 Years | 5 Years |

*Wilden Max Flow measured at 125 psi Air Pressure.

PERFORMANCE

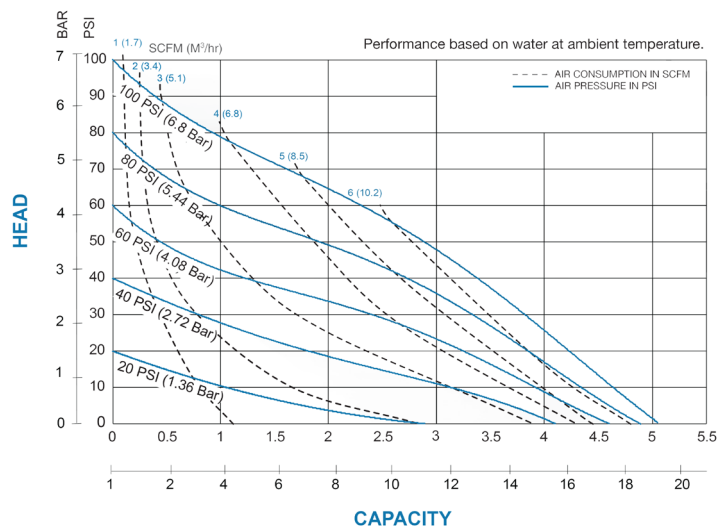

We know the importance of choosing the right equipment to match your process. Whatever your pump requirements, we will help you achieve the best pumping solution.

When Pump Knowledge Matters