



KelairPumps

CALL 1300 789 466

HD20F NON-METALLIC 2" (50 MM) AODD
HEAVY DUTY FLAP VALVE PUMP

WHEN PUMP
KNOWLEDGE
MATTERS

Designed to solve the most common challenges.

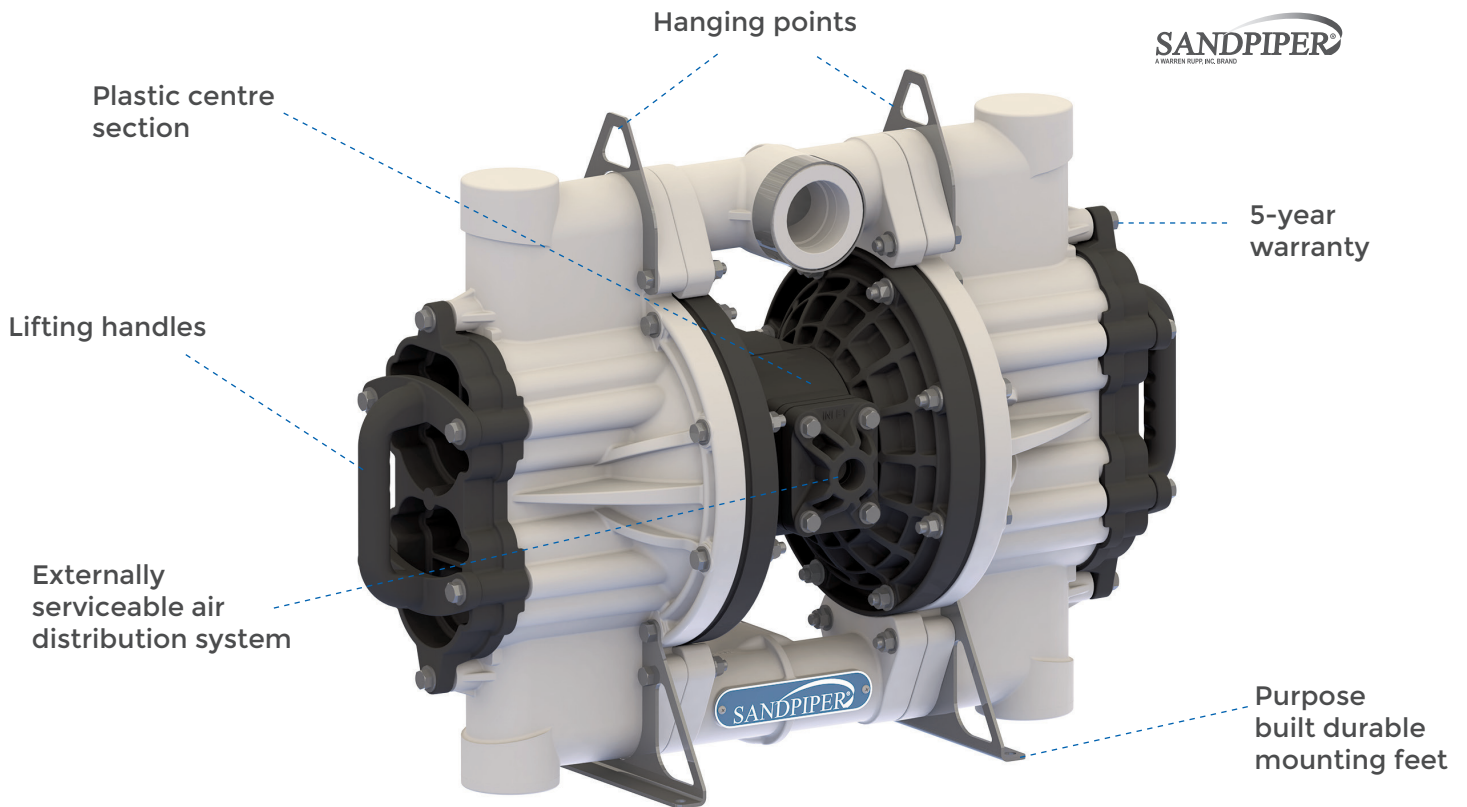

Heavy duty flap valve pump ideal for handling solids and corrosive fluids.

The SANDPIPER 2" HD20F Non-Metallic AODD Pump delivers a high flow rate while offering portability. This ultimate utility pump gives you flexibility, mobility and reliability. The 2" AODD pump uses a patented air valve system to provide non-stalling, lube-free performance. It has been designed to solve the most common challenges in mine dewatering, sump and chemical transfer applications.

FEATURES & BENEFITS

- **Light Weight and Portable** - Weights range from 21 kg
- **All Bolted Construction** - Durable and high pressure capable
- **Bottom Discharge** - For pumping out of tough areas
- **Flap Check Valves** - Provides large solids capabilities
- **Durable Diaphragm Connecting Rods** - Reliable and consistent diaphragm control
- **Dynamic Manifold Connections** - 90°-180° rotation options
- **Solids Range** - up to 1.8" (46mm)
- **Superior Dry Prime** - Up to 7m of water
- **Certifications Available** - CE, ATEX and ABS

KELAIR PUMPS AUSTRALIA - 1300 789 466

When Pump Knowledge Matters



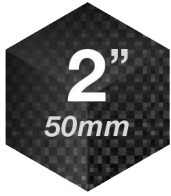

HD20F Non-Metallic

SOLIDS HANDLING

Up to 1.8" (46mm)

MAX FLOW

567 LPM

MAX PRESSURE

7.0 bar (100 psi)

DISPLACEMENT

1.9 Litres

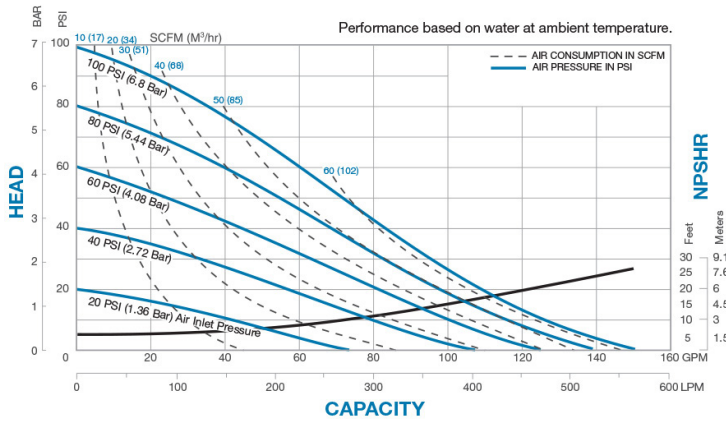

OPTIONS

Porting	Wet End	Elastomers		Air End
2" NPT / BSP Threaded	Polypropylene	Nitrile (Buna)	Fluorocarbon (FKM)	Polypropylene
2" ANSI / DIN Combination Flange	Stainless Steel (Seats only)	Neoprene	EPDM	
		Hytrel®	Urethane	
		Santoprene®		

Santoprene® is registered tradename of Exxon Mobil Corp. Hytrel® is a registered trademark of E.I. duPont de Nemours and Company.

APPLICATIONS

Durable and portable pumps suitable for:

- Dewatering
- Solids laden fluids
- Light chemical transfer
- Wastewater transfer

PERFORMANCE GUARANTEES

- Diaphragm Connecting Rod Guarantee
- 5-Year Limited Product Warranty
- Anti-Stall Air Valve Guarantee



Sandpiper AODD pumps set-up in roll frames is a versatile option.

The robust and at the same time weight-saving design of the SANDPIPER® HD20F plastic pump enables a mobile and flexible use for the conveyance of solid and corrosive liquids in different industrial areas.

We know the importance of choosing the right equipment to match your process. Whatever your pump requirements, we will help you achieve the best pumping solution.

When Pump Knowledge Matters