



KelairPumps

CALL 1300 789 466

O-Pro™ Seal Technology  
SIMPLE, PROVEN & RELIABLE

WHEN PUMP  
KNOWLEDGE  
MATTERS

# Seals made for challenging fluid sealing applications.

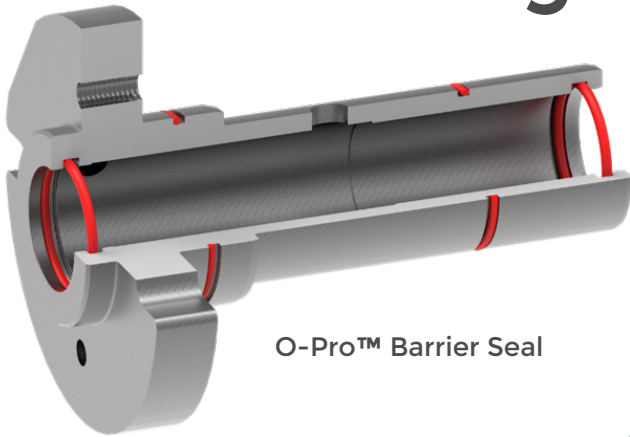

O-Pro™ Barrier Seal

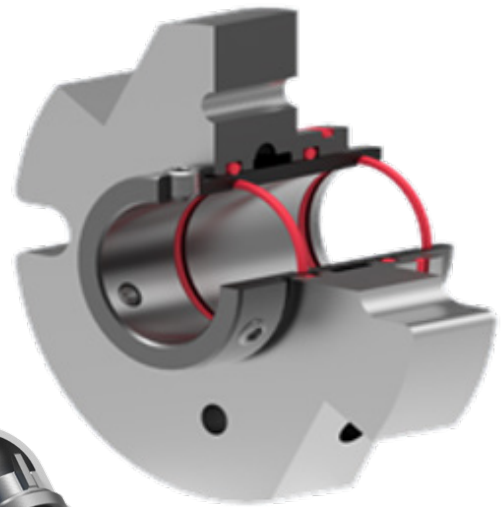

O-Pro™ Guard

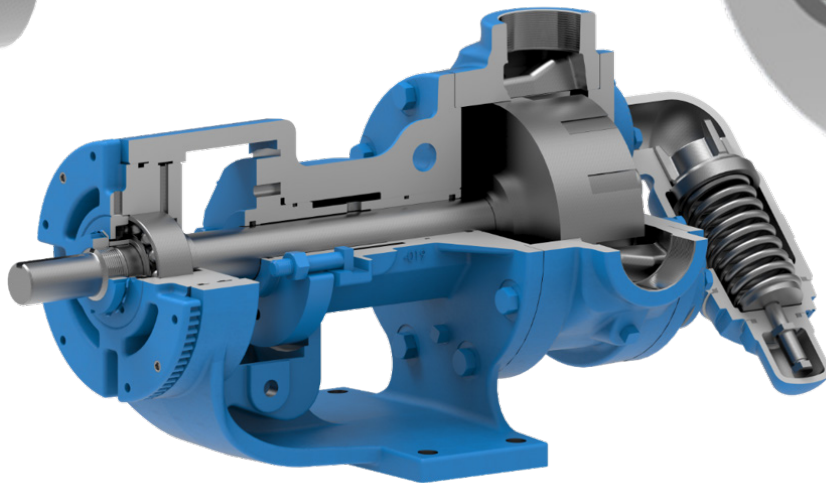

**VIKING  
PUMP**

Viking Pump have developed a new sealing technology for their extensive range of Universal Seal series pumps – the O-Pro™.

O-Pro™ Seals utilize a series of O-rings to create a robust seal and lubrication chamber, all in one.

O-Pro™ Barrier seal functions as both a seal and bracket bushing; while the O-Pro™ Guard seal is a simple retrofit option.

If you are looking to stop a leaking packed or sealed pump the O-Pro seal technology may be your best solution.

## BENEFITS

- Improved reliability
- Low maintenance
- Easy to repair
- Elimination or significant reduction of unplanned downtime

O-Pro™ seals are perfect for difficult to seal products like chocolate, ink, paint, molasses, edible oil, corn syrup, honey, lube oil, grease, asphalt, wax, resin, starch, fat, isocyanate, adhesive and more.

With the option to have O-Pro seals installed in a new pump or to retrofit an existing one, you can stop your pump leaking today.

KELAIR PUMPS AUSTRALIA - 1300 789 466

*When Pump Knowledge Matters*



Viking has responded to industry's need for a reliable, low maintenance, and easy-to-repair pump that provides leakage prevention and food safety. The new O-ring seal design is the answer to fluid leaking from packing, as well as gaskets, which can cause slip and fall hazards.

## O-Pro™ Barrier Seal (OPB)

The O-Pro™ Barrier seal stops process fluids from entering the bracket and eventually leaking from the pump.

- O-Pro™ Barrier seal functions uniquely as both seal and bracket bushing
- Uses a series of O-rings to create robust seal and lubrication chamber
- OPB Keeps product out of bracket area to prevent binding with minimal section exposed to product

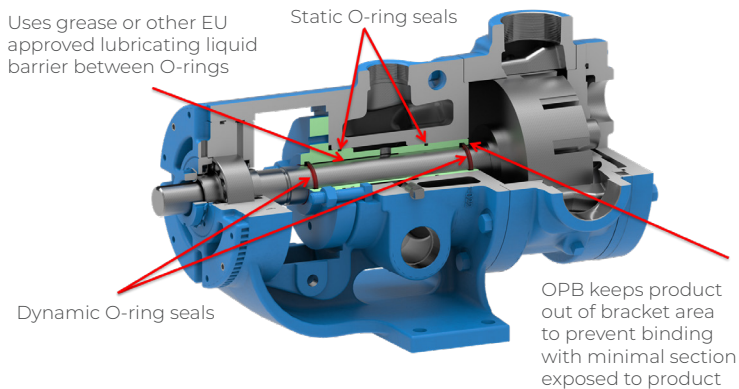

## O-Pro™ Guard Protection (OPG)

The O-Pro™ Guard seal is a compact design for an easy retrofit answer for any leaking pump.

- O-Pro™ Guard Protection replaces packing or mechanical seal by sealing between the bracket, sleeve & shaft surfaces with a series of O-rings
- Stainless-steel construction utilising a hardened sleeve mechanically secured to the shaft to ensure superior performance
- Sleeve becomes potential wear item significantly reducing repair costs in the event of O-ring wear
- O-rings and lubrication provide a robust seal for many applications

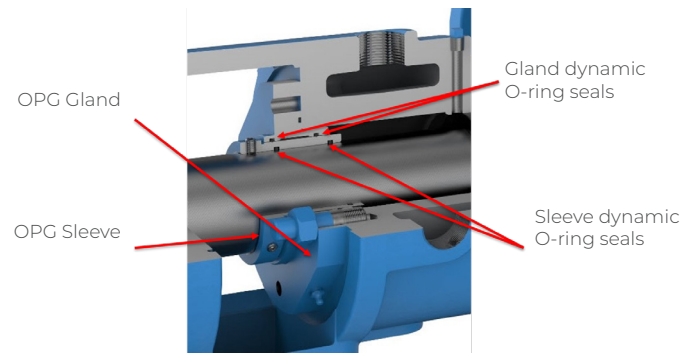

## APPLICATIONS

- Chocolate & Confectionery
- Molasses
- Affination Syrup
- Peanut Butter
- Asphalt
- Resin
- Grease
- Maltodextrin
- Pre-Polymer (polyol and isocyanate)
- Isocyanate
- Adhesive
- Starch
- Corn Syrup
- Silicone
- Tall Oil
- Animal Fat (Feed mill)
- Sodium Laurel Ethyl Sulfate (SLES)
- Animal Fat (Feed Mill)

### Within Chocolate & Confectionery Market

- Chocolate Liquor
- Dark Chocolate
- White Chocolate
- Cocoa Butter
- White Paste
- Corn Syrup
- Sugar Free Chocolate
- Enrober Chocolate
- Peanut Butter
- TiO2 based coating for hard shell candies

## MAXIMUM RPM

Seal Type	H	HL	K	KK	L	LQ	LL	LS	Q	QS	N	R	RS
O-Pro™ Barrier	1000	1000	780	780	640	640	520	640	470	470	330	250	260
O-Pro™ Guard	760	760	520	520	N/A	520	520	520	350	350	280	225	225

We know the importance of choosing the right equipment to match your process. Whatever your pump requirements, we will help you achieve the best pumping solution.

*When Pump Knowledge Matters*