

YOUR **PARTNER** *FOR*
INNOVATIVE PUMPING **SOLUTIONS**

FOCUS MARKET:

CHOCOLATE & CONFECTIONERY



VIKING PUMP®

VIKING PUMP®

Viking Pump has been a trusted partner in reliability with chocolate and confectionery processors around the world for more than a century. As the world's leading positive displacement process pump manufacturer, solving difficult liquid transfer problems is what we do. And it doesn't get more difficult than chocolate, so you can rely on Viking's experience and expertise.

Viking has worked closely with processors to overcome the many difficulties of pumping chocolate and developed hundreds of different, unique pump designs for each different chocolate liquid.

For example:

- Hardened parts to minimize wear by abrasive cocoa liquor
- Extra clearances and drilled idler gears to prevent caramelization of white chocolate
- Grooves to promote flow behind the rotor to prevent solids buildup on sugar-free chocolate
- Special seals for cocoa butter and fats

Customers, however, told us they wanted ONE pump to do it all. So we incorporated all of those features, and more, into our 1224A-CHC Series chocolate pumps to enable standardization of pumps and spares throughout the plant.

Whether the task is to transfer cocoa mass from a ball mill across the plant to a blending tank, or to recirculate yogurt coating in a closed loop to feed a series of panners, or to continuously recirculate tempered milk chocolate from an enrobing machine's sump to the feed trough, or a hundred other possibilities, Viking's gentle, reliable pumps will improve your operational efficiency.



THE VIKING PUMP ADVANTAGE

- EC1935 Compliant constructions
- Internal O-rings create a sealed lubrication chamber for the bracket bushing, increasing bushing life
- Trusted and proven with world leading chocolate manufacturers
- Pre-defined chocolate pump constructions to make business easy
- Low shear design protects delicate chocolate suspensions
- Hardened materials provide long life on abrasive liquors and chocolates
- Internal gear principle handles viscosities ranging from thin cocoa butter to thick peanut butter
- Simple, in-house maintenance
- Vertically integrated manufacturing process, from raw materials to finished product, meets ISO 9001:2015 quality standards

CHOCOLATE & CONFECTIONERY PROCESS: SIMPLIFIED FLOW

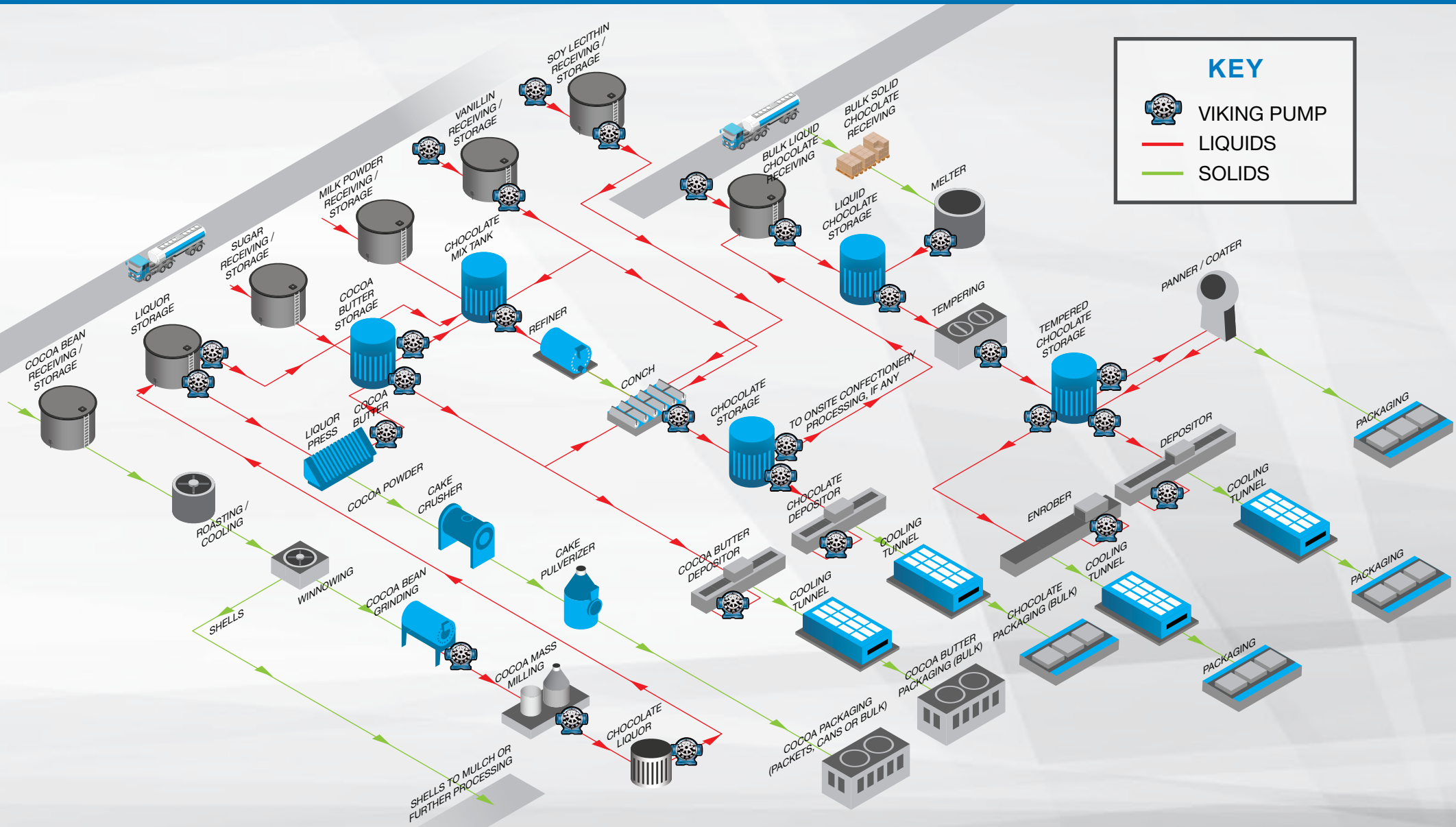

Viking pumps are used in processing chocolate (bean to bulk), making confections (bulk to bar), and plants that do both (bean to bar). Whether it's loading or unloading tanker trucks, transferring materials from one process to another, or recirculating dark, milk or white chocolate in an enrobing machine, Viking does it all. Typical applications are shown on the process map above.

VIKING CHOCOLATE PUMP INNOVATION

Designed specifically for chocolate and confectionery liquids, these pumps offer:

LEAK PREVENTION

A patent-pending back pull-out O-Pro™ Barrier Seal with double O-ring seals prevents leakage of chocolate or cocoa butter along the shaft, for increased plant hygiene, reduced slip and fall hazard.

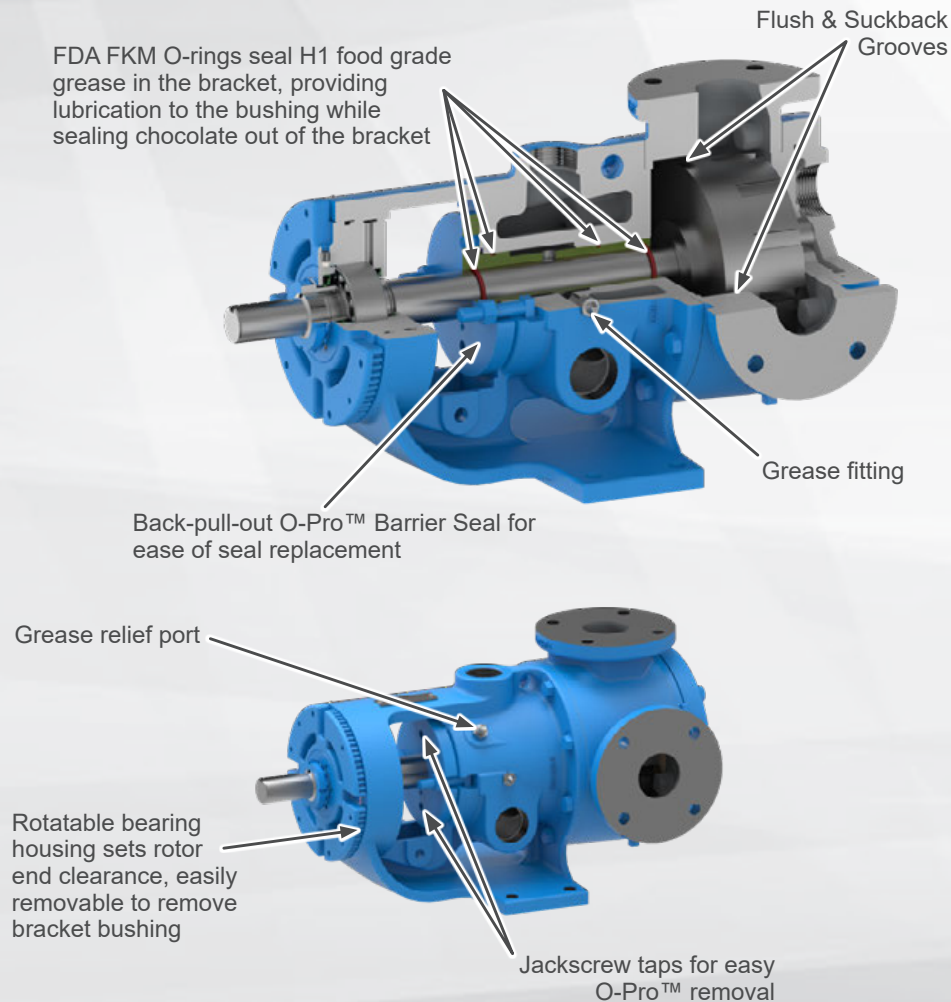

RELIABILITY

1224A-CHC1 models for chocolate liquids minimize frictional heat at bushings and prevent solids buildup that can cause seizing. The O-Pro™ Barrier Seal is lubricated with clean food-grade grease instead of chocolate, and keeps chocolate out of the bracket while providing superior shaft support; the extra-clearance idler gear and bushing are drilled to ensure flow between the bushing and pin to reduce heat; and flush and suckback grooves on the casing create flow behind the rotor to eliminate buildup. High-strength steel or ductile iron rotors handle high viscosities, and hardened iron bushings and hardened steel shafts minimize wear. There's no packing to adjust, which eliminates common overtightening problems.

LESS PUMP & PART VARIATION

The 1224A-CHC2 models for non-chocolate liquids are identical to CHC1, except the casing does not have flush and suckback grooves, for higher efficiency on thin liquids like cocoa butter. This reduces pump and spare part variation, and enables easy conversion from CHC1 to CHC2 and vice versa. Seal kits enable low-cost conversion of existing Viking Universal Seal pumps to the O-Pro™ Barrier Seal.

FOOD SAFETY - EC1935 COMPLIANT

The pumps are constructed of food grade materials and carry the EC1935 mark to limit leaching of harmful substances into food, and are suitable for use on low hazard foods like chocolate, according to your HACCP plan.

SIMPLE MAINTENANCE

O-rings are replaceable with the pump in-place, when configured with spacer couplings allow space to remove the O-Pro™ Barrier Seal. Jack screws in seal kits allow easy O-Pro™ Barrier Seal removal. Proven O-ring sealing technology means low cost seal replacement. Recommended re-greasing interval is every 500 hours of operation.

VIKING CHOCOLATE PUMPS

O-PRO™ BARRIER SEAL BUSHING

The O-Pro™ Barrier Seal combines a bracket bushing and seal gland, with double O-ring seals, to seal chocolate **out** of the bracket and food grade grease **in** to provide lubrication for the bracket bushing

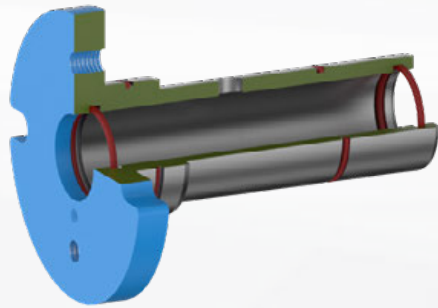

DRILLED IDLER

The idler gear features a hardened iron bushing, extra clearances, and holes drilled through to ensure flow between the idler and pin, preventing chocolate from burning

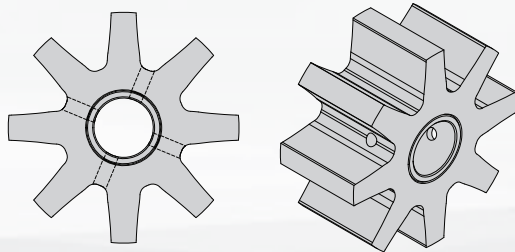

NAMEPLATE - EC1935 COMPLIANT

Pump nameplate features the EC1935 compliant cup and fork symbol to provide assurance of food-compatible materials of construction



MATERIALS OF CONSTRUCTION

- **Casing, Head, Bracket & Idler:** Cast Iron (except H/HL idlers powdered metal, Q idler hardened steel)
- **Rotor:** Steel (Sizes H, HL, K, LQ, LL, Q); Ductile Iron (Sizes KK, LS, QS)
- **Shaft:** Hardened Steel
- **Bracket & Idler Bushings:** Hardened cast iron
- **Seals:** Food grade gaskets and FDA FKM O-rings
- **Lubricants:** Food grade grease
- **Jacketing:** Jacketed heads and brackets standard to enable melting chocolate before startup

PERFORMANCE

- **Maximum Chocolate Temperature:** 225°F / 107°C
- **Maximum Chocolate Differential Pressure:** 200 PSI / 14 BAR

CHC1 Model for Cocoa Liquor, All Chocolates, Pastes (≈5,000 to 200,000 cPs)	Max Speed	Ports			CHC2 Model for Cocoa Butter, Oils, Lecithin (≈1 to 5,000 cPs)	Max Speed
	RPM	Size	Type	Location		RPM
H1224A-CHC1	280	1.5"	NPT	90°	H1224A-CHC2	1000
H1224A-CHC1	280	2"	Flange	90°	H1224A-CHC2	1000
HL1224A-CHC1	280	1.5"	NPT	90°	HL1224A-CHC2	1000
HL1224A-CHC1	280	2"	Flange	90°	HL1224A-CHC2	1000
K1224A-CHC1	190	2"	NPT	90°	K1224A-CHC2	780
K1224A-CHC1	190	2" / 3"	Flange	90°	K1224A-CHC2	780
KK1224A-CHC1	190	2"	NPT	90°	KK1224A-CHC2	780
KK1224A-CHC1	190	2" / 3"	Flange	90°	KK1224A-CHC2	780
LQ1224A-CHC1	125	3" / 4"	Flange	90°	LQ1224-CHC2	640
LL1224A-CHC1	125	3" / 4"	Flange	90°	LL1224A-CHC2	520
LS1224A-CHC1	125	3" / 4"	Flange	90°	LS1224A-CHC2	640
Q1224A-CHC1	100	4"	Flange	90°	Q1224A-CHC2	470
QS1224A-CHC1	100	*4" / **6"	Flange	*90° / **180°	QS1224A-CHC2	470

THE VIKING PUMP SOLUTION

INTERNAL GEAR PUMPING PRINCIPLE: HOW IT WORKS

Viking Pump invented the internal gear pumping principle more than a century ago. The pump rotor (outer gear) is mounted to the shaft and rotates at slow speeds, turning the idler (inner) gear on the idler pin, mounted on the pump head. The gears open large voids between their teeth as they turn, creating low pressure zones that enable atmospheric pressure to flow chocolate in. As the gears re-mesh, the voids collapse and chocolate flows out the discharge port. Flow rate is directly proportional to speed, so variable speed drives can provide precise process control. Direction of flow is reversible, to strip material from the line after pumping.

Clockwise Rotation (viewed from shaft end)

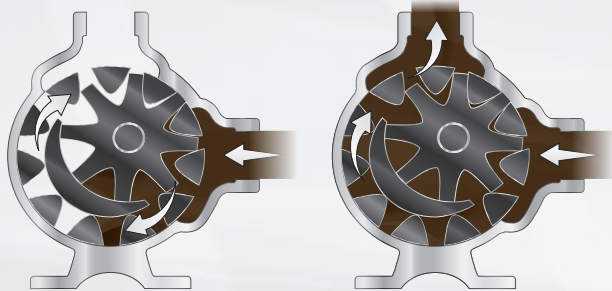

Counter-Clockwise Rotation (viewed from shaft end)

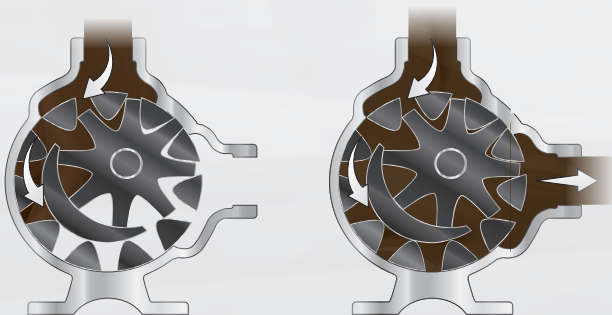

O-PRO™ BARRIER SEAL VS. PACKING

We have listened to customers and evolved our offering to provide a seal that reduces loss of product due to leakage.



At Left:
(O-Pro™ Barrier Seal pump with no leakage)

At Right:
(Packed pump leaking cocoa butter)

IT'S A
~~REVOLUTION~~
CHOCO

GLOBAL **LEADER** *IN POSITIVE DISPLACEMENT* **PUMPING** SOLUTIONS



VIKINGPUMP.COM

VERTICALLY INTEGRATED PRODUCTION PROCESS:

Viking Pump operates two foundries, a 200,000+ sq. ft. machining, assembly and testing center, and an extensive product engineering and testing lab in its world headquarters in Cedar Falls, Iowa, USA. This level of vertical integration ensures maximum quality, ability to satisfy special needs, and to meet project schedules.



Contact Your Stocking Distributor Today

Distributed By:

AUSTRALIAN DISTRIBUTOR

VIKING PUMP, INC.
A Unit of IDEX Corporation
406 State Street
Cedar Falls, Iowa 50613 U.S.A.
Telephone: (319) 266-1741
Fax: (319) 273-8157
vikingpump.com



CALL 1300 789 466

When Pump Knowledge Matters
www.kelairpumps.com.au

