



ALBIN PUMP ALH

Hose Pumps / Instruction Manual





ALH

Table of Contents

1 HOW TO USE THIS MAINTENANCE MANUAL	4
2 PUMP USE AND TRAINING	4
2.1 - Use of the pump	4
2.2 - Responsibility	4
2.3 - Training and instructions	4
3 DESCRIPTION	5
3.1 - Product identification	5
3.2 - Operation principle	5
3.3 - Pump construction	6
3.3.1 - Pumps ALH05 to ALH20	6
3.3.2 - Pumps ALH25 to ALH65	7
3.3.3 - Pumps ALH80 to ALH125	8
3.4 - Pump hose	9
3.5 - Pump gearbox	9
3.6 - Electrical Motor	9
3.7 - Available Options	9
4 INSTALLATION	10
4.1 - Unpacking and control	10
4.2 - Conditions of installation	10
4.3 - Setup	10
4.4 - Piping	10
4.5 - Pump lifting	11
5 PUMP START-UP	11
5.1 - Preparations	11
5.2 - Pump start-up	11
6 MAINTENANCE	11
6.1 - Emptying and filling of the lubricant	11
6.2 - Hose cleaning	13
6.3 - Hose replacement	13
6.3.1 - Removing the hose	13
6.3.2 - Cleaning of the pump casing	15
6.3.3 - Reassembly of the hose	15
6.4 - Replacement of spare parts	17
6.4.1 - Replacement of pump shoes (except ALH05, ALH10, ALH15, ALH20)	17
6.4.2 - Replacement of the seal ring (REF 27) and the shaft seal (REF 26)	18
6.5 - Shoe shimming	21
6.6 - Maintenance and periodical controls	22
6.7 - ALHS series complementary information	23
6.7.1 - Set up	23
6.7.2 - Pump starting	23
6.7.3 - Bearing case dismantling and lip seal (REF 26) replacement	23
6.7.4 - Maintenance and periodical controls	23



ALH

Table of Contents

7 STORAGE	23
7.1 - Pump storage	23
7.2 - Hose storage	24
8 TROUBLESHOOTING	24
9 CHARACTERISTICS AND TECHNICAL SPECIFICATIONS	26
9.1 - Performances curves	26
9.2 - Overall dimensions	29
9.3 - Nomenclature	33
9.4 - ALH Spare parts list	43
9.5 - ALHS Bearing case parts list	46
9.6 - Hose rupture and vacuum system parts list	46
9.7 - Lubrication table	47
9.8 - Shoe shimming table	47
9.9 - Generated noise and temperature	48
9.10 - Expansible hub assembly and disassembly: generalities	49
9.11 - Torque	50
9.12 - Weight	51
10 COMPLEMENTARY INSTRUCTIONS FOR ATEX CERTIFIED MATERIAL	52
11 SECURITY FORM	60
12 STATEMENT OF CE COMPLIANCE	61



ALH

Manual Usage / Security and Guarantees

1 | HOW TO USE THIS MAINTENANCE MANUAL

This manual is specific to ALBIN PUMP SAS (ALBIN PUMP) ALH series peristaltic pumps. It allows the users to install, to start and to carry out maintenance on these pumps. All persons, fitters and users must read this maintenance manual in its entirety. Documents concerning the gearbox, the electrical motors, as well as all other options (hose rupture detector, etc.) are provided in annex. Refer to the applicable section in this document to understand specific details regarding that component.

Your local ALBIN distributor can be contacted regarding information not contained in this manual. For a quicker reply, please provide the following information:

- Type of pump
- Pump serial number
- Reference of order

You can also visit our website albinpump.com for further information.

2 | PUMP USE AND TRAINING

2.1 - USE OF THE PUMP

The pump was defined for a specific application. Any other use which does not comply with envisaged use is not guaranteed. ALBIN PUMP cannot be held responsible for damage or possible wounds / injuries produced during the use of the pump. The pump was designed in accordance with EU norms and applicable directives. Use the pump for applications that have been approved by the appropriate ALBIN personnel or distributors. If you want to change your application, first contact your ALBIN PUMP distributor.

2.2 - RESPONSIBILITY

ALBIN PUMP is not responsible for damage or wounds / injuries caused by mishandling of products, disregard of security directives and maintenance instructions contained in this manual, or by negligence during the installation, use, service, or repair of ALBIN hose pumps. Moreover, additional directives of security can be necessary according to working conditions or according process. Contact your ALBIN PUMP distributor if you notice a potential danger during the use of the pump.

2.3 - TRAINING OF THE USER AND INSTRUCTIONS

Every person who installs, uses or performs any operations of maintenance on the pump must be qualified and must have previously read this technical manual. Any temporary personnel must be supervised by skilled users.

The order of execution of operations defined in this manual must be absolutely respected. Store this manual next to the pump so that it can be consulted at any time.



ALH

Description

3 | DESCRIPTION

3.1 - IDENTIFICATION OF THE PUMP

ALBIN PUMPS are identifiable by the pump plate located on the frame. The plate includes the pump type and serial number of the pump. This serial number leads to all information concerning building materials, nature of the hose, characteristics of the gearbox and characteristics of the motor. The gearbox and motor have their own descriptive plate that states the reduction ratio, power, and electrical voltage.

3.2 - OPERATION PRINCIPLE

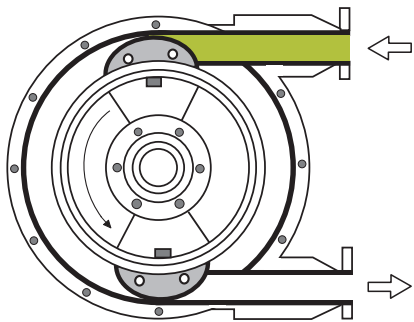

○ PHASE 1

The pump hose is compressed successively by two pressing shoes assembled on a rotating wheel. The first shoe, by pressing the walls of the hose, will create a vacuum and attract the pumped liquid into the hose.

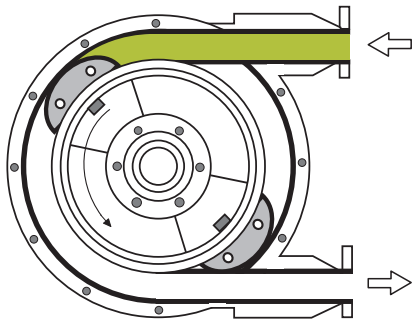

○ PHASE 2

The pumped liquid has now entered the hose. The second shoe will compress the hose and push the liquid towards the pump outlet.

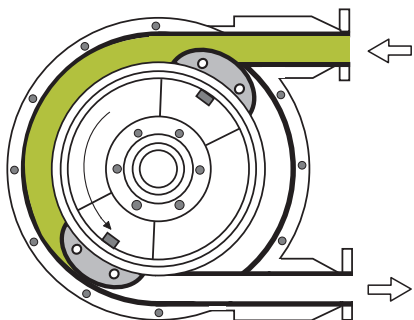

○ PHASE 3

As soon as, at the discharge side, the shoe is detached from the hose, the other shoe diametrically opposite is already in compression thus avoiding an internal product leakage. The product is then successively sucked and pushed due to the wheel rotation.



ALH

Description

3.3 - PUMP CONSTRUCTION

3.3.1 - PUMPS ALH05 TO ALH20

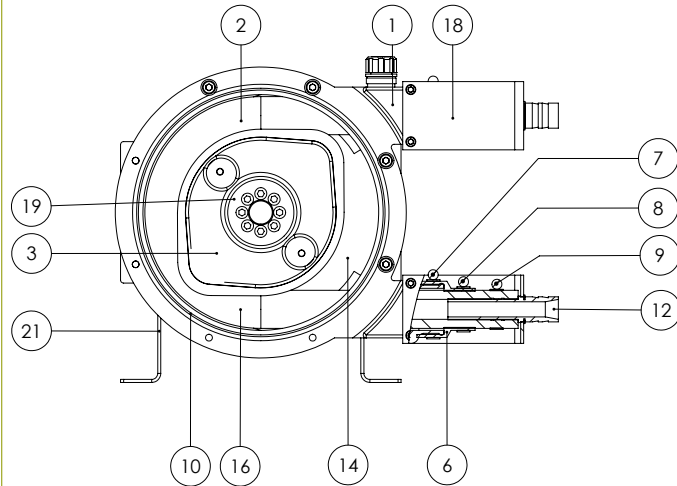

PUMP ALH15 - ALH20

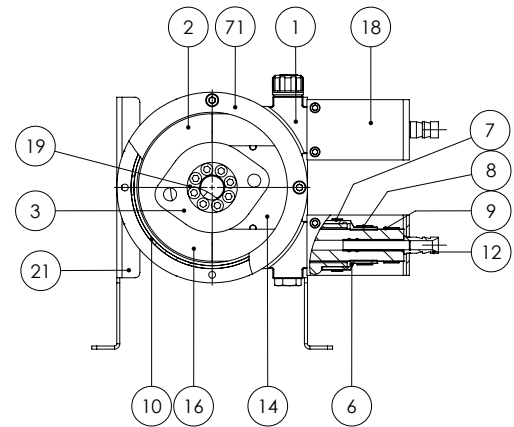

PUMP ALH05 - ALH10

Part No	DESIGNATION	ALH05 - 10	ALH15-20
1	CASING	CAST IRON	CAST IRON
2	COVER	POLYCARBONATE	POLYCARBONATE
3	WHEEL	CAST IRON	CAST IRON
6	SLEEVE	EPDM	EPDM
7	CLAMP ON CASING	STAINLESS STEEL	STAINLESS STEEL
8	CLAMP SLEEVE / HOSE	BICHROMATED STEEL	BICHROMATED STEEL
9	CLAMP ON HOSE	BICHROMATED STEEL	BICHROMATED STEEL
10	SEAL COVER	NITRILE	NITRILE
12	INSERT	STAINLESS STEEL / PPH / PVDF	STAINLESS STEEL / PPH / PVDF
14	LUBRICANT	GLYCERIN BLEND	GLYCERIN BLEND
16	HOSE	NR / NBR / EPDM / NBR FOOD / VITON® / HYPALON® / NR-FOOD	NR / NBR / EPDM / NBR FOOD / VITON® / HYPALON® / NR-FOOD
18	BRACKET	ELECTROPLATED STEEL	ELECTROPLATED STEEL
19	HUB	STEEL	STEEL
21	FRAME	ELECTROPLATED STEEL	ELECTROPLATED STEEL
71	COVER FLANGE	ELECTROPLATED STEEL	WITHOUT FLANGE



ALH

Description

3.3.2 - PUMPS ALH25 TO ALH65

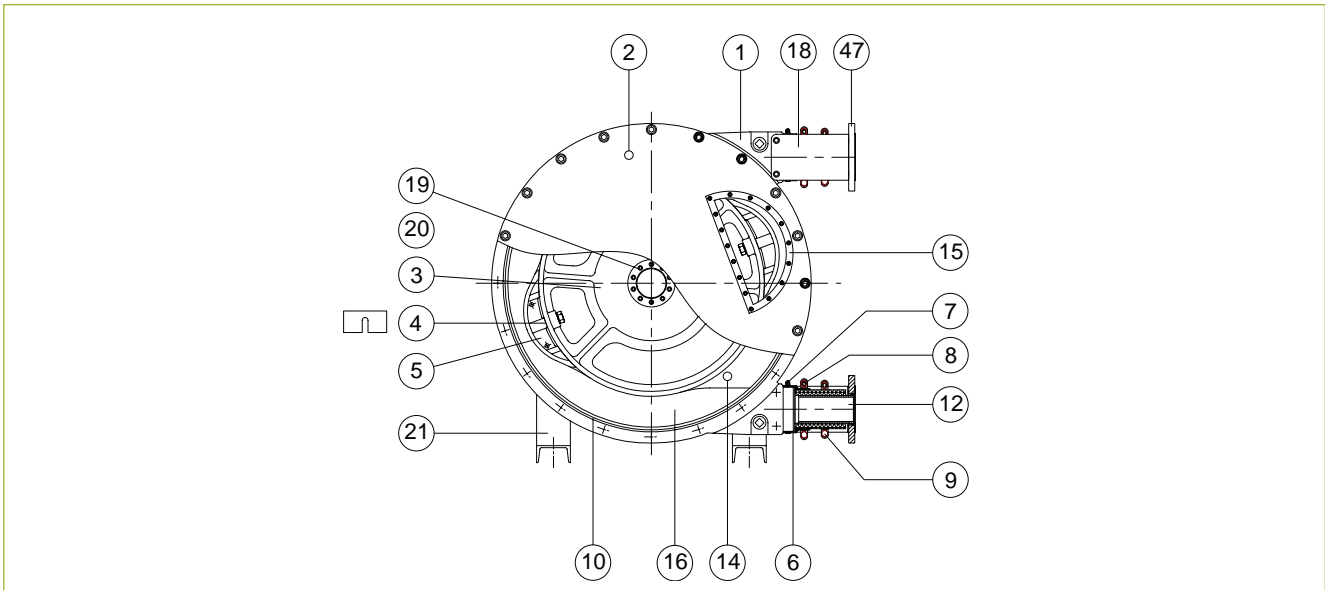

Part No	DESIGNATION	ALH25 - 32 - 40	ALHX40 - ALH50 - 65 - ALHX65
1	CASING	DUCTILE CAST IRON	DUCTILE CAST IRON
2	COVER	ELECTROPLATED STEEL	STEEL
3	WHEEL	DUCTILE CAST IRON	DUCTILE CAST IRON
4	SHIM	GALVANIZED STEEL	GALVANIZED STEEL
5	SHOE	CAST IRON	CAST IRON
6	SLEEVE	EPDM	EPDM
7	CLAMP ON CASING	STAINLESS STEEL	STAINLESS STEEL
8	CLAMP SLEEVE / HOSE	STAINLESS STEEL	STAINLESS STEEL
9	CLAMP ON HOSE	STAINLESS STEEL	BICHROMATE STEEL
10	SEAL COVER	NITRILE	NITRILE
12	INSERT	STAINLESS STEEL / PPH / PVDF	STAINLESS STEEL / PPH / PVDF
14	LUBRICANT	GLYCERIN BLEND	GLYCERIN BLEND
15	SIGHT GLASS SEAL	POLYCARBONATE	POLYCARBONATE
16	HOSE	NR / NBR / EPDM / NBR FOOD / VITON® / HYPALON® / NR-FOOD	NR / NBR / EPDM / NBR FOOD / VITON® / HYPALON® / NR-FOOD
18	BRACKET	ELECTROPLATED STEEL	ELECTROPLATED STEEL
19	HUB	STEEL	STEEL
21	FRAME	STEEL	STEEL
46	SIGHT GLASS SEAL	NITRILE	NITRILE
47	INLET/OUTLET FLANGE	STAINLESS STEEL	STAINLESS STEEL



ALH

Description

3.3.3 - PUMPS ALHX80 TO ALH125

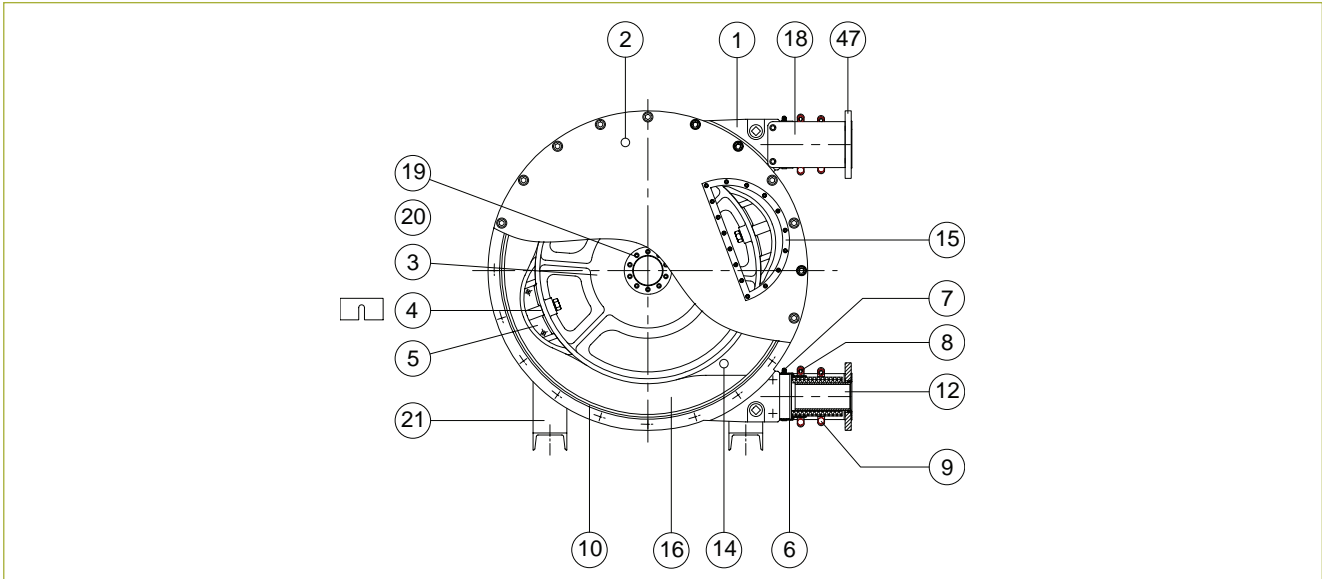

Part No	DESIGNATION	ALHX80 - ALH80	ALH100 - ALH125
1	CASING	DUCTILE CAST IRON	DUCTILE CAST IRON
2	COVER	STEEL	STEEL
3	WHEEL	DUCTILE CAST IRON	DUCTILE CAST IRON
4	SHIM	GALVANIZED STEEL	GALVANIZED STEEL
5	SHOE	DUCTILE CAST IRON	DUCTILE CAST IRON
6	SLEEVE	EPDM	EPDM
7	CLAMP ON CASING	STAINLESS STEEL	STAINLESS STEEL
8	CLAMP SLEEVE / HOSE	STAINLESS STEEL	STAINLESS STEEL
9	CLAMP ON HOSE	BICHROMATE STEEL	BICHROMATE STEEL
10	SEAL COVER	NITRILE	NITRILE
12	INSERT	STAINLESS STEEL / PPH / PVDF	STAINLESS STEEL / PPH / PVDF
14	LUBRICANT	GLYCERIN BLEND	GLYCERIN BLEND
15	SIGHT GLASS	POLYCARBONATE	POLYCARBONATE
16	HOSE	NR / NBR / EPDM / NBR FOOD / VITON® / HYPALON® / NR-Food	NR / NBR / EPDM / NBR FOOD / VITON® / HYPALON® / NR-Food
18	BRACKET	ELECTROPLATED STEEL	ELECTROPLATED STEEL
19	HUB	STEEL	
20	BOLT ON PLATE	DUCTILE CAST IRON	
21	FRAME	STEEL	STEEL
46	SIGHT GLASS SEAL	NITRILE	NITRILE
47	INLET/OUTLET FLANGE	STAINLESS STEEL	STAINLESS STEEL



ALH

Description

3.4 - HOSE

The ALBIN hoses are manufactured according to very strict specifications to acquire the best performances of the pump and to assure an optimum hose life. They are available in six materials: Natural Rubber (NR), perbunan (NBR), EPDM, NBR food, Viton®, and Hypalon®. The material of the hose must be compatible with the pumped liquid. Consult an ALBIN PUMP distributor to define the best hose for your process or consult the chemical resistance table on our website albinpump.com.

HOSE DIMENSIONS

mm (Inch)

PUMP	Ø INSIDE	THICKNESS	LENGTH
ALH05	5 (0.2)	13.5 (0.5)	570 (22.4)
ALH10	10 (0.4)	11 (0.4)	570 (22.4)
ALH15	15 (0.6)	11 (0.4)	830 (32.7)
ALH20	20 (0.8)	9 (0.3)	830 (32.7)
ALH25	25 (1)	14.5 (0.6)	1090 (42.9)
ALH32	32 (1.2)	15.5 (0.6)	1300 (51.2)
ALH40	38 (1.5)	13.5 (0.5)	1300 (51.2)
ALHX40	40 (1.6)	13.5 (0.5)	1500 (59.1)
ALH50	51 (2)	15 (0.6)	1820 (71.7)
ALH65	60 (2.4)	13.5 (0.5)	1850 (72.8)
ALHX65	65 (2.5)	17.5 (0.7)	2075 (81.6)
ALHX80	80 (3.1)	17.5 (0.7)	2400 (94.5)
ALH80	80 (3.1)	21.5 (0.8)	2910 (114.5)
ALH100	100 (3.9)	22 (0.9)	3410 (134.2)
ALH125	125 (4.9)	21.25 (0.8)	4000 (157.4)

3.5 - GEAR BOX

Our standard gearboxes are coaxial gearboxes for pumps ALH05 to ALHX40 and planetary for pumps ALH50 to ALH100. ALH125 can be equipped with both. They have been sized according to the important radial loads of the pump. Consult the gearbox maintenance manual provided with the pump to know the quantity of lubricant requested as well as the periodicity of oil change.

3.6 - ELECTRICAL MOTORS

The standard motors provided on our pumps are squirrel-cage motors and have a 230/400 V and 400/690 V 50/60 Hz three-phase voltage. Voltage is dependent on the selected power supply. If the pump has to work in a potentially explosive environment, please refer to the complementary information on ATEX compliances and contact your ALBIN PUMP distributor.

3.7 - AVAILABLE OPTIONS

ALBIN PUMP offers several options for their pumps:

- Hose rupture detector.
- Revolution-counter.
- Pulsation dampener.
- Air vacuum assistance (for highly viscous liquids).
- Variable speed drive.
- Mechanical variator.

Please contact your ALBIN PUMP distributor for any information about these different options.



ALH Installation

4 | INSTALLATION

4.1 - UNPACKING AND CONTROL

During the receipt of the pump, please follow the instructions printed on the packing. Make a visual inspection to insure that no damage occurred during shipment. If this is the case, please contact your ALBIN PUMP distributor as soon as possible.

4.2 - CONDITIONS OF USE

ALH pumps can work in atmospheres where the temperature is situated between -20°C (-4°F) and 45°C (113°F). Pumps are coated with a 150µ paint which will protect them against certain aggressive environments. They are designed for indoor and outdoor setup.

4.3 - SET UP

Before installing the pump, check the following points:

- The pump is delivered with a frame provided with four anchoring holes. It must be fixed on a solid base with a slope which does not exceed 5mm for 1m and must be firmly fastened to this one.
- Require enough space around the pump to carry out maintenance. If such was not possible, consider the moving of the pump to a space provided for this purpose.
- Make sure that the room is adequately ventilated to relieve the heat generated by the pump. Leave a space behind the motor ventilator hood so as not to obstruct air intake.

4.4 - PIPING

Suction line piping:

- The internal diameter of the piping must be equal to or greater than that of the pump hose.
- It must be the shortest and most direct possible to avoid suction loss.
- Suction pressures at higher operating pressures may cause the pump to rotate when the pump is disengaged. Above 1 bar, consider adding a suction line valve to prevent this occurrence.
- Limit the presence of bends and make sure that they are as large as possible.
- Make sure that piping can support the service pressure of the pump.

Discharge line piping:

- The internal diameter of piping must be equal to or greater than to that of the pump hose, see §3.4.
- It must be the shortest and most direct possible to avoid discharge pressure loss.
- Limit the presence of bends and make sure that they are as large as possible.
- Provide a space for a pulsation dampener (see picture below).
- If there is a valve on the discharge line, install a pressure relief valve or an over pressure protection gauge to avoid any possible damage to the pump and to the installation.
- It is recommended to install a flexible line to help absorb pulsation.

During the pump ground study, provide enough space for the hose change as well as the possible installation of a pulsation dampener. Distance (L) is the required length for hose removal.

DIMENSIONS

mm (Inch)

PUMP	L
ALH05	400 (15.7)
ALH10	400 (15.7)
ALH15	500 (19.7)
ALH20	500 (19.7)
ALH25	800 (31.5)
ALH32	1000 (39.4)
ALH40	1000 (39.4)
ALHX40	1200 (47.2)

PUMP	L
ALH50	1400 (55.1)
ALH65	1400 (55.1)
ALHX65	1500 (59.0)
ALHX80	1600 (63.0)
ALH80	2000 (78.7)
ALH100	2800 (110.2)
ALH125	3000 (118.1)

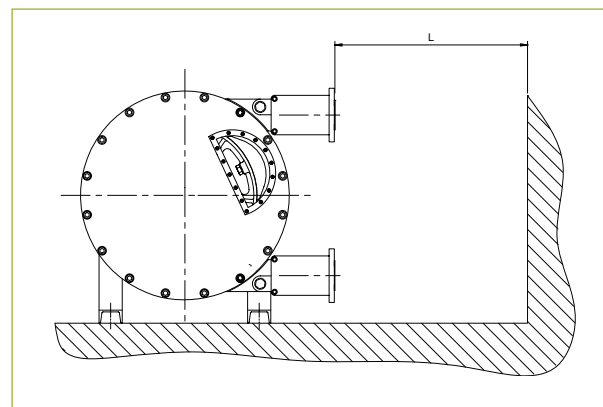



ALH

Installation / Pump Start-up / Maintenance

4.5 - LIFTING THE PUMP

Pumps are provided with two lift holes (eyebolts) placed on the upper part of the frame. While lifting the pump, respect the following points:

- Lift the complete hose pump using the lifting rings plus additional support on the gearbox and the motor using suitably rated straps or slings.
- Never exceed the upper limits of lift and control the motorized pump weights in the table below.
- The motorized pump, given its centre of gravity, will tend to overbalance on the pump head side. Make sure that the persons are at a secure distance from the pump to avoid any risk of wound.
- Never raise the pump otherwise than by the pump's lifting rings.
- Never raise the pump by its orifices nor by its brackets.

WEIGHT

kg (lbs)

PUMP	ALH05-10	ALH15	ALH20	ALH25	ALH32	ALH40	ALHX40
Approx. Weight	25 (55.1)	35 (77.2)	35 (77.2)	80 (176.4)	130 (286.6)	145 (319.7)	210 (463)

PUMP	ALH50	ALH65	ALHX65	ALHX80	ALH80	ALH100	ALH125
Approx. Weight	315 (694.5)	335 (738.5)	484 (1067.0)	700 (1543)	930 (2050.3)	1250 (2755.8)	1750 (3858.1)

5 | PUMP START-UP

5.1 - PREPARATIONS

- a. Connect the electrical motor in accordance with the local rules and regulations. Perform this work by qualified personnel.
- b. Make sure that the lubricant level arrives at the level of the sight glass (see §9.7 for lubricant table and §6.1 for an image). Add lubricant if required by the breather or by the sight glass, see §6.1 for instructions on emptying and filling the lubricant.
- c. Make sure the shimming of the pump is according to the pump process, see §6.5 shoe shimming. Refer to §9.8 for shoe shimming tables.
- d. Check the direction of rotation of the pump. It is recommended to install a rotation inverter on the motor for the hose change.

5.2 - START-UP

- a. Install piping at the inlet and outlet of the pump.
- b. Make sure that valves at the inlet and outlet are opened.
- c. Start the pump by checking its direction of rotation by the sight glass.

6 | MAINTENANCE

6.1 - EMPTYING AND FILLING OF THE LUBRICANT

Refer to §6.6 to know the periodicity of lubricant change.

- 1 - Stop the pump.
- 2 - Place a tray underneath the drain plug (REF 23).

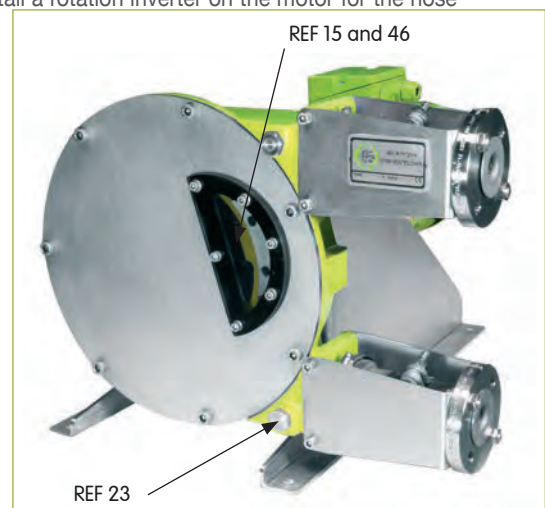



ALH

Maintenance

- 3 - If necessary, install a tap and a drain circuit instead of the drain plug (REF 23).
- 4 - Make sure that this tray can contain the quantity of lubricant during the drainage process, see lubricant volume table §9.7.
- 5 - Unscrew the plug (REF 23) and undertake emptying.
- 6 - Position and tighten the plug (REF 23) by applying PTFE band or waterproof paste or close the drain tap.

NOTE : If the pump is mounted with the inlet/outlet positioned upwards, lubricant drainage is obtained by unscrewing cover screws in the lower part.

- 7 - Remove the sight glass (REF 15) as well as its seal (REF 46) and fill the casing with the ALBIN lubricant, see lubricant table §9.7. You can also fill the casing by the breather cap (REF 52) situated at the back of the pump casing. The required lubricant level is underneath the bottom edge of the sight glass (see photo beneath).
- 8 - Check the state of the seal (REF 46) and reassemble the sight glass (REF 15) or tighten the breather cap (REF 52).

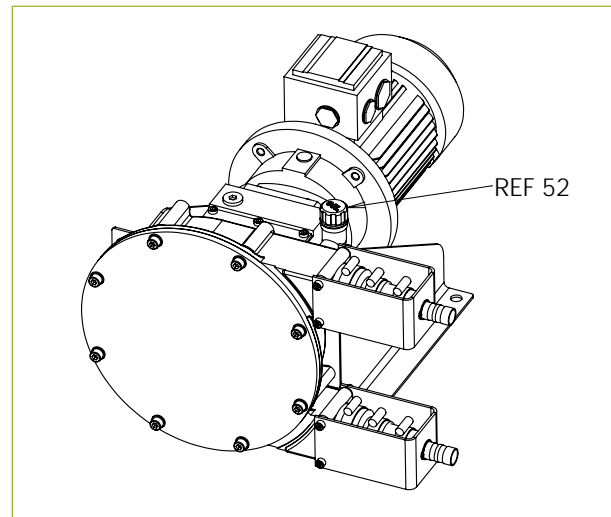

FOR MODELS ALH05, ALH10, ALH15 and ALH20:

Unscrew higher breather plug (REF 52) of the pump. Place a funnel inside the plug hole and fill the casing with the ALBIN lubricant (see lubricant table §9.7). The necessary volume of lubricant is just underneath the shaft line.



ALH

Maintenance

6.2 - HOSE CLEANING

The hose cleaning can be done without removing the hose. It can be done with water or with a cleaning liquid (check compatibility with hose material). With numerous products, it is necessary to clean the hose after every pumping session in order to avoid the hardening of the product inside this one.

CAUTION! Make sure that the cleaning liquid temperature is adapted to the hose material.

6.3 - HOSE REPLACEMENT

CAUTION! Before any hose change, check the following points:

- This service has to be performed by skilled personnel that is acquainted with this manual.
- Isolate the pump from the power supply. Inlet and outlet valves have to be closed to minimize product loss. The pump will need to be re-connected power to expel and load in the hose in subsequent steps.
- Always carry clothes and necessary protection according to the pumped product.
- Respect all security and environmental rules necessary for the manipulation of the pumped product.

6.3.1 - HOSE REMOVAL

1 - Disconnect and remove the suction and discharge piping.

2 - Drain the lubricant as explained in §6.1.

3 - At the suction end, loosen clamps (REF 8 and 9) (photo 1).

Extract the insert (REF 12) and remove the flange (REF 47) (photo 2). The flange may require an additional tool (e.g. prybar) to be removed, carefully, as to not damage the insert/flange. Remove the brackets REF 18 (photograph 3).

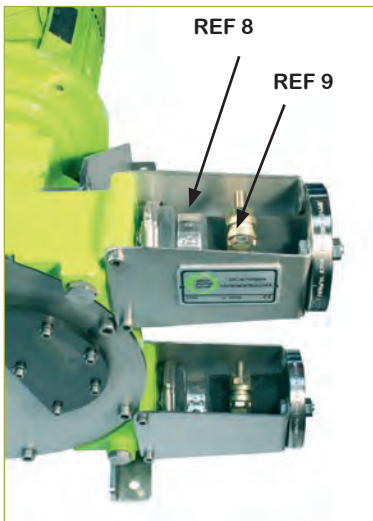

PHOTO 1

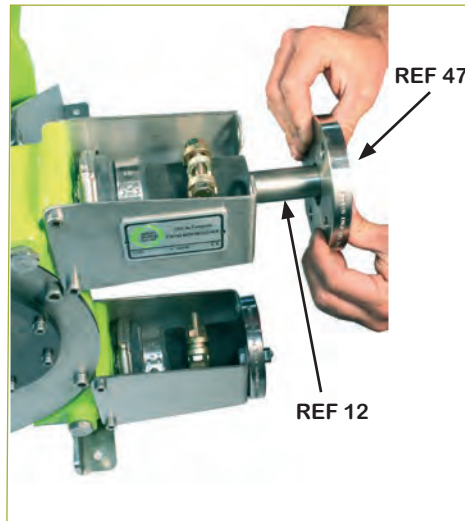

PHOTO 2

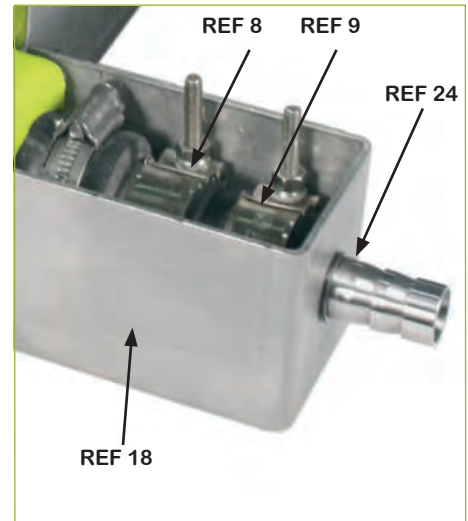

PHOTO 3

FOR MODELS ALH05, ALH10, ALH15 and ALH20:

Remove circlips using circlips pliers (REF 24) and dismantle bracket (REF 18). Extract insert (REF 12). Carefully perform these actions to avoid damaging the ribbed fittings.



ALH Maintenance

4 - At the discharge end, loosen clamps (REF 8 and 9). Extract the insert (REF 12) and remove the flange (REF 47) as well as the brackets (REF 18) (photograph 7). Remove clamps (REF 8 and 9) (photograph 7).

5 - Jog run the motor to deliver the hose from the pump casing at the outlet side.

WARNING! The hose can come out of the pump casing very fast and cause harm. Check that nobody is in front of the pump's orifices while removing the hose.

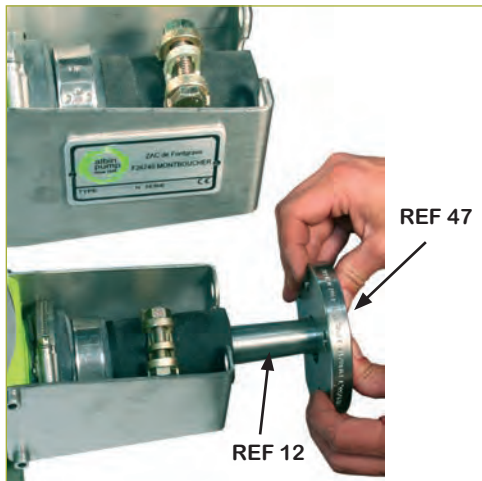

PHOTO 4



PHOTO 5

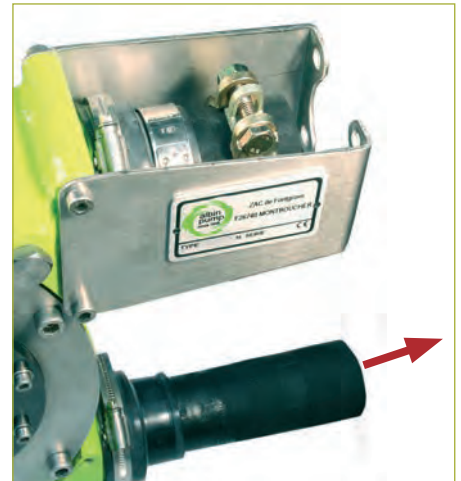

PHOTO 6

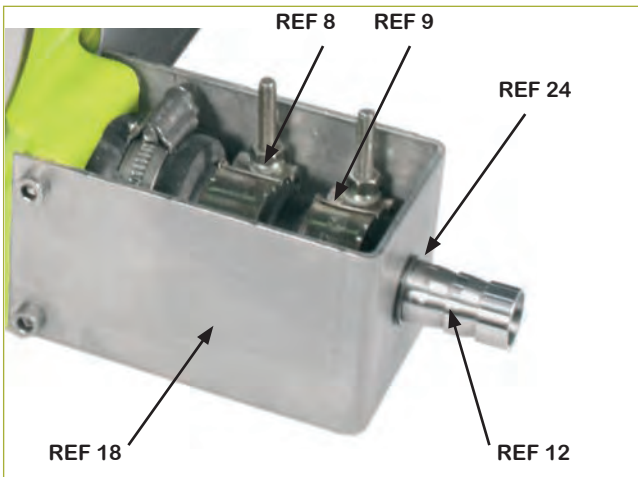

PHOTO 7

FOR MODELS ALH05, ALH10, ALH15 and ALH20:

At the pump outlet, loosen clamps (REF 8) and (REF 9). Remove circlips (REF 24) and dismantle bracket REF 18. Extract insert (REF 12). Remove clamps (REF 8) and (REF 9). Carefully perform these actions to avoid damaging the ribbed fittings.



ALH

Maintenance

6.3.2 - PUMP CASING CLEANING

This operation is necessary when a hose has burst and when the product has contaminated the inside of the pump casing. Perform these steps with caution. If hazardous chemicals were being pumped, use caution when removing the lubricant.

- 1 - Unfasten cover screws by leaving two screws partly fastened to the casing. Slightly withdraw the cover from the casing and fix a shackle in one of the cover's highest fastening holes (see picture below). Pumps ALH80, ALH100 and ALH125 are equipped with a lifting ring. Install a lift equipment in this shackle and slightly raise the cover. Unfasten the remaining screws and withdraw the cover. **For cover weight please refer §9.12**
- 2 - Check the state of the cover seal (REF 10) §6.4.1 and replace if necessary.
- 3 - Check the state of wear of the pressing shoes (REF 5) and replace them if necessary, see §6.4 Replacement of spare parts.

CAUTION! Worn shoes can contribute to improper compression and premature wearing of the hose.

- 4 - In the case of a hose burst, it is possible that the shaft seal (REF 26) §6.4.2 as well as the seal ring (REF 27) §6.4.2 have been notably damaged when pumping an abrasive liquid. Relate to §6.4 if a replacement of these parts is necessary.
- 5 - Wash the casing with clear water and withdraw any residues.
- 6 - Dry the pump casing entirely.
- 7 - Replace the cover seal in its groove.
- 8 - Reassemble the pump cover.

6.3.3 - REASSEMBLY OF THE HOSE

WARNING! You should never assemble a new hose without a mounted cover.

For Torque settings (hose clamps and brackets), refer §9.11

- 1 - Pre-assemble the flange (REF 47) at the inlet port with two bolts (photo 1).
- 2 - Clean the new ALBIN hose carefully. Slightly coat it with ALBIN lubricant. Lightly lubricate the inside of the sleeve (REF 6).



**FOR MODELS ALH05, ALH10, ALH15
and ALH20**

Temporarily mount the bracket (REF 18)
at the inlet port.

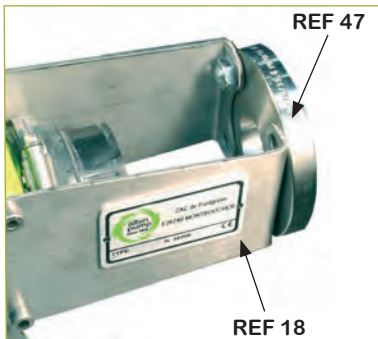

PHOTO 1

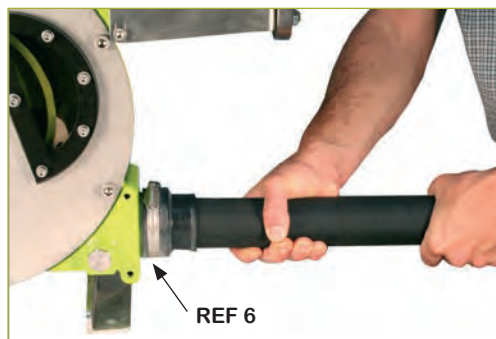

PHOTO 2



ALH

Maintenance

- 3 - Insert the hose by the outlet port (REF 6) (Photo 2).
- 4 - Reverse the direction of rotation of the motor.
- 5 - While pushing on the hose, jog run the motor and check the direction of rotation.
- 6 - The shoes mounted on the wheel are going to “swallow” the hose and push it out of the inlet port. Always by giving jolts, a gap is maintained between the hose and flange in order to slide the clamps over the hose and into position. Once the clamps are placed loosely over the hose, jog the pump to get the hose flush with the flange. (REF 47) (photo 3).
- 7 - Assemble the clamps (REF 8 and 9) on the inlet side. Clamp (REF 8) is to be mounted on the sleeve to ensure the sealing. Clamp (REF 9) needs to be installed at an equal distance between the flange and sleeve. Mount the insert (REF 12) into the hose. Tighten clamps (REF 8 and 9).

If you meet difficulties in introducing inserts into the pump hose, coat them slightly with ALBIN lubricant. Never use another lubricant.

- 8 - Assemble the brackets (REF 18) and pre-assemble flange (REF 47) on the outlet side with two temporary bolts.

FOR MODELS ALH05, ALH10, ALH15 and ALH20

Dismantle the bracket (REF 18). Mount clamp (REF 8) and 9 on the hose. Mount the insert (REF 12) into the hose. Fix bracket (REF 18) and block the insert with circlips (REF 24). Tighten the clamp (REF 8) and 9.

FOR MODELS ALH05, ALH10, ALH15 and ALH20

Assemble the bracket (REF 18) at the outlet side.

- 9 - Reverse the direction of rotation of the motor.
 - 10 - A gap is maintained between the hose and flange in order to slide the clamps over the hose and into position. Once the clamps are placed loosely over the hose, jog the pump to get the hose flush with the flange.
 - 11 - Undertake operation step 7 at discharge side.
 - 12 - Fill the pump with the necessary quantity of ALBIN lubricant see §6.1 and §9.7.
 - 13 - Take away the temporary flange bolts and fix the piping on both suction and discharge sides.
 - 14 - Open the valves at the suction and discharge sides.
 - 15 - Check the direction of rotation of the pump.
- Check for any possible lubricant leakage by the inserts, sleeves or cover.



PHOTO 3



ALH

Maintenance

6.4 - REPLACEMENT OF SPARE PARTS

6.4.1 - REPLACEMENT OF PUMP SHOES (EXCEPT ALH05, ALH10, ALH15, ALH20)

- 1 - Jog run the motor and position one of the shoes in front of the sight glass.
- 2 - Cut the power supply.
- 3 - Drain the lubricant, see §6.1.
- 4 - Remove the pump cover (REF 2) as well as the cover seal (REF 10).
- 5 - Disassemble the shoe (REF 5) by removing the bolt and washer. The shoe which is not in contact with the hose and put aside the shims if any. Check that the pin (REF 30) is still on the wheel (ALH25 to ALHX80).
- 6 - Mount a new shoe on the wheel (do not to forget the washer REF 29). Slide the shims between the shoe and the wheel before tightening.

CAUTION! Be careful of the position of the shoe with the centering (REF 30) (ALH25 to ALHX80).

- 7 - Tighten the shoe onto the wheel For Torque settings please refer to §9.11.
- 8 - Reassemble the cover with 3 temporary bolts disposed at about 120° between each other.
- 9 - Jog run the motor 180° to bring the second shoe in front of the sight glass.
- 10 - Remove the cover once again and undertake operations step 5 to 7.
- 11 - Reposition the cover and tighten all cover screws.

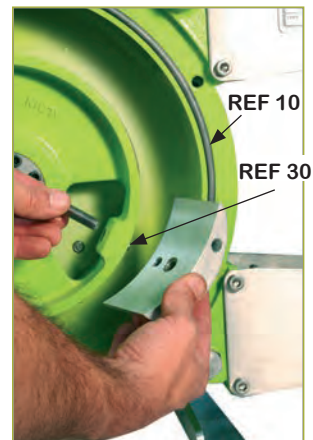
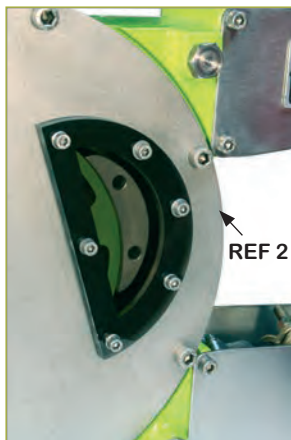



ALH

Maintenance

6.4.2 - REPLACEMENT OF THE SEAL RING (REF 27) AND THE SHAFT SEAL (REF 26)

ALBIN hose pumps are equipped with a leakage channel (refer below image) that allows to see the wear of the seal ring or the shaft seal. This channel is at the back of the pump casing underneath the gearbox flange. It also protects the gearbox seals by leaving the lubricant or the product to pass freely at the back of the pump casing.

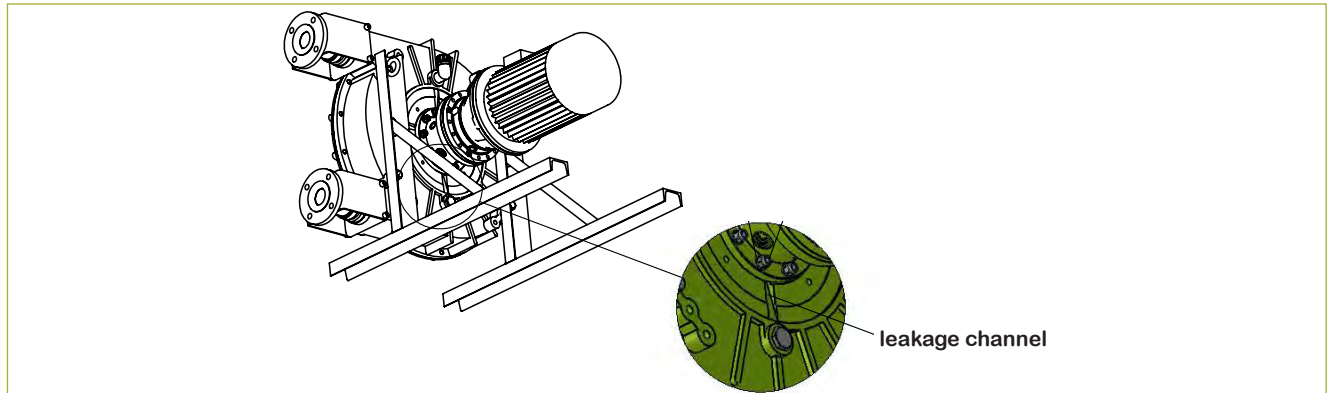

PUMPS FROM ALH05 TO ALHX65

(Refer to the nomenclature §9.3 for the landmarks of parts).

- 1 - Isolate the pump from the power supply.
- 2 - Empty the lubricant and clean out the pump, see §6.1.
- 3 - Remove the pump hose, see §6.3.1.
- 4 - Disassemble the pump cover and withdraw the cover seal (REF 10).
- 5 - Disassemble the wheel by unscrewing the expansible hub (REF 19). Refer to §9.10 for expansible hub assembly and disassembly.
- 6 - Withdraw the wheel of the pump shaft with a suitable lifting equipment.
- 7 - Support the gear motor with a suitable lifting equipment.
- 8 - Unscrew the nuts (Gearbox Studs) to free the gearbox from the casing (REF 41) and withdraw the gearbox from the pump casing.
- 9 - Extract the damaged seal ring (REF 27).
- 10 - Slip on the spacer ring (REF 73) only for ALH50 and ALH65 HELICAL GEARBOX models Refer to §9.3 exploded view image for location, if necessary and glue to the shaft. Position the new seal ring (REF 27) against the spacer ring or the gearbox shaft's shoulder. Fill the gap between the key-way and the seal ring with silicone mastic to ensure correct.

For Pumps ALH100 and ALH125 the wheel is automatically positioned by the spacer ring and seal ring. Therefore no adjustment is necessary.

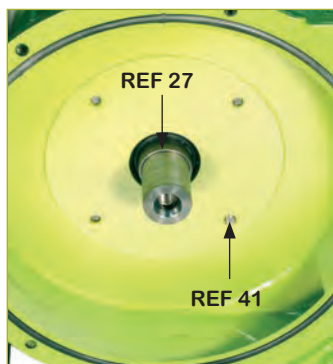



ALH

Maintenance

- 11 - Withdraw the shaft seal (REF 26) with a drift punch.
- 12 - Replace a new shaft seal (REF 26) with an appropriate tool (wooden or plastic cylinder). Check the mounting position of the seal (opened side turned to the cover).
- 13 - Mount the gear motor on the casing being careful not to damage the shaft seal. Tighten the nuts (REF 41) with their washers (REF 72).
- 14 - Mount the wheel and hub on the pump shaft by positioning it referring to the table and the drawings below.

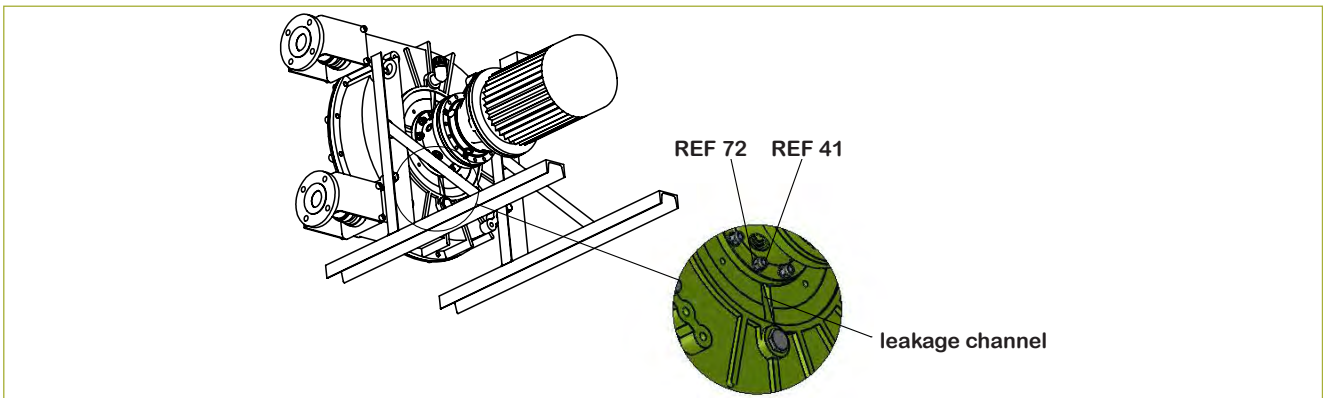

REP 19

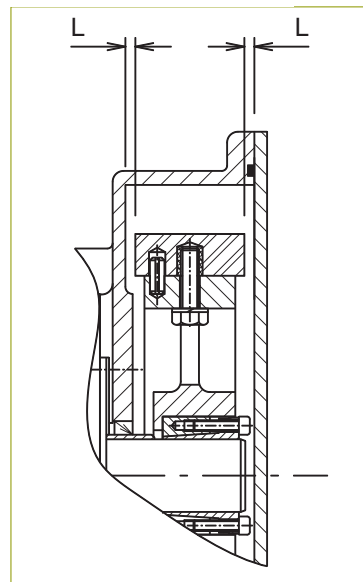

DIMENSIONS / TOLERANCE

mm (Inch)

PUMP	ALH05 - ALH10	ALH15 - ALH20	ALH25	ALH32	ALH40	ALHX40	ALH50 - ALH65 - ALHX65	ALHX80	ALH80	ALH100	ALH125
Distance casing / shoe (L)	4 (0.15)	2.75 (0.1)	5.5 (0.21)	6 (0.23)	2.5 (0.09)	5 (0.19)	3 (0.11)	6.5 (0.25)	8 (0.31)	10 (0.39)	15 (0.59)
Tolerance + or -	0.5 (±0.02)	0.5 (±0.02)	0.5 (±0.02)	0.5 (±0.02)	0.5 (±0.02)	0.5 (±0.02)	0.5 (±0.02)	0.5 (±0.02)	0.5 (±0.02)	0.5 (±0.02)	0.5 (±0.02)



ALH

Maintenance

- 15 - Cross tighten the expansible hub with a dynamometric spanner, certified tooling required, to the correct torque figure check the wheel position once again and re-adjust if necessary. Refer to §9.10 for expansible hub assembly and disassembly.
- 16 - Mount the cover seal (REF 10) in its groove and mount the cover.
- 17 - Mount the pump hose as stated in §6.3.3.

TORQUE

Nm (Ft-lbs)

PUMP TYPE	TORQUE
ALH05, ALH10, ALH15, ALH20	15 (11.1)
ALH25, ALH32, ALH40	13 (9.6)
ALHX40	34 (25.1)
ALH50, ALH65	35 (25.8)
ALHX65	90 (66.3)
ALHX80	110 (81.1)
ALH80 (shaft Ø90)	110 (81.1)
ALH80 (shaft Ø100)	190 (140.1)



PUMPS FROM ALHX80 TO ALH125

(refer to the nomenclature for the landmarks of parts §9.3)

- 1 - Undertake the same operation steps 1 to 10 as for pumps ALH05 to ALH65.
- 2 - Disassemble the seal flange (REF 25) and withdraw the damaged shaft seal with a screwdriver or a similar tool.
- 3 - Take the new shaft seal (REF 26) between the thumb and the index and by tightening your fingers, form an "8" figure. The seal can now be inserted into its groove by respecting the mounting position (see drawing).
- 4 - Mount the gear motor on the pump casing (see operation step 13).
- 5 - Replace the O-ring (REF 67) if necessary and reassemble the seal flange.
- 6 - For pumps ALHX80 and ALH80, undertake operation steps 14 to 17 of previous chapter. For pumps ALH100 and ALH125, undertake operation step 14 of previous chapter. Then block the wheel with the washer (REF 60) and the screw (REF 59) and finish with operation steps 16 and 17 of previous section.

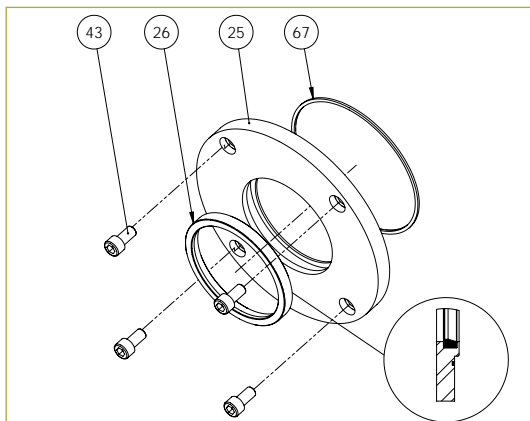



ALH

Maintenance

6.5 - SHOE SHIMMING

NOTE: this paragraph does not concern pumps ALH05 to ALH20.

CAUTION! The shimming of shoes is an operation which consists of adding shims under the shoe to stop any internal leakage. An internal leakage considerably reduces the life time of the hose as well as the flow. As a result, it is essential to adjust the shoe's shimming according to the rotation speed of the pump, the desired discharge pressure and the liquid viscosity.

WARNING! Never run the pump without the sight glass.

The shoe shimming can be made without disassembling the hose or the cover.

Shims are inserted or withdrawn by the sight glass as pointed out below :

- 1 - Jog run the motor and bring a shoe in front of the sight glass.
- 2 - Cut the power supply of the pump.
- 3 - Unscrew the sight glass bolts and withdraw taking care in not damaging the seal.
- 4 - Slightly unscrew the shoe's fastening bolt(s) and lift the shoe off the wheel with a screwdriver or a similar tool.
- 5 - You can now either slide in or withdraw the necessary number of shims under the shoe.

Consult the shimming table §9.8 to determine the precise number of shims according to the application.

- 6 - Tighten the shoe bolts, reference table in §9.11.
- 7 - Reassemble the sight glass with its seal.
- 8 - Re-connect and jog run the motor to bring the second shoe in front of the sight glass.
- 9 - Cut the power supply of the pump.
- 10 - Repeat operations 3, 4, 5, 6 and 7. Replace the sight glass seal (REF 46) if necessary.





ALH

Maintenance

6.6 - MAINTENANCE AND PERIODIC INSPECTIONS ALH AND ALHS SERIES

1	Pump hose replacement.	Preventative maintenance suggests changing the pump hose after 90% of the life time of the first hose.	see §6.3
2	Lubricant replacement.	At the end of 2 hose changes or 5000 hours run time, unless there is a hose rupture (replace immediately).	see §6.1
3	Gearbox oil replacement.	Refer to the gearbox maintenance manual provided with the pump.	
4	Replacement of the seal ring (REF 27).	In case of presence of lubricant in the leak channel.	see §6.4.2
5	Replacement of the shaft seal (REF 26).	In case of presence of lubricant in the leak channel.	see §6.4.2
6	Replacement of the shaft seal (REF 105) and (REF 106) (ALHS series).	In case of presence of oil in the leak channel or at the lip seals.	see §6.4.2 and §6.6
7	Replacement of the shoes.	The contact surface of a shoe should be flat. Replace if the contact surface is concave.	see §6.4.1
8	Replacement of the cover seal (REF 10).	In the case of a leak around the pump cover.	see §6.3.2
8	Replacement of the sleeves (REF 6).	If these are damaged.	Refer to §6.3 Perform operations 1, 2, 3 and 4 of §6.3.1 and change sleeves. Respect directives of security.
9	Replacement of the bearings (REF 103) and (REF 104) (ALHS series)	If there are abnormal noises coming from the bearing case.	see §6.4 and §6.6
9	Check the lubricant level.	Before starting the pump and periodically during the pump service.	see §6.1
10	Check for lubricant leakage at the leakage channel.	Before starting the pump and periodically during the pump service.	see §6.4
11	Check the pump casing to discern possible leakages around the cover, the sight glass, the flanges and the sleeves.	Before starting the pump and periodically during the pump service.	
12	Check for wear on the shoe's pressing surface.	At every hose change.	see §6.4
13	Check the presence of a gearbox oil leakage.	Before starting the pump and periodically during the pump service.	see §3.5
14	Check for strange noises coming from the pump, gearbox and bearing case or abnormal pump casing temperature.	Periodically during the pump service.	



ALH

Maintenance / Storage

6.7 - ALHS SERIES INFORMATION

6.7.1 - SET UP

Before the setup of the pump, check the following points:

- The ALHS pump is delivered without a frame. Assembly holes are at the back of the pump for assembly on a frame. Dimensions of these assembly holes can be found in § 9.2. The pump with its drive and frame must be fixed to a solid base with a slope which does not exceed 5mm for 1m and must be firmly fastened to this one.
- The pump frame must be built in order to support the stress and deformations delivered by the pump and drive. It should be built by qualified staff with good engineering practice. In no case ALBIN PUMP is responsible for its construction or conception.
- The alignment of pump and drive shafts must be made in accordance with instructions given by the manufacturer of the coupling. Refer to the specific notice of such material. To achieve alignment and coupling, use a perfectly straight ruler to control the misalignment, and a feeler gauge for angular misalignment. Control four points (top, bottom, left, right) at each stage of the installation (after setting on foundations, after fixing pipes and after a first start).
- Make sure there is enough room around the pump to carry out maintenance. If that was not the case, envisage the moving of the pump in a space provided for this purpose.
- Make sure the room is adequately ventilated to relieve the heat generated by the pump. Leave a space behind the motor ventilator hood so as not to obstruct the air intake.

6.7.2 - PUMP STARTING

Follow the steps described in §5. The hose is not mounted on bare shaft pumps when delivered. Therefore, hose mounting operations should be followed before the starting up.

6.7.3 - BEARING CASE DISMANTLING AND LIP SEAL (REF 26) REPLACEMENT

Carry out operations described in §6.4.2 Disassemble the bearing case in the same way as for the gearbox.

- 1 - Remove lip seals (REF 105) and REF 106 from the bearing case.
- 2 - Remove the circlips (REF 107).
- 3 - Remove the shaft with the bearings.
- 4 - Carry out the disassembly of the bearings and replace them together with the shaft (REF 102) if necessary.
- 5 - Remove the shaft and the bearings, circlips and O-rings. Fill up the bearing box with grease through the greaser positioned on the top of the box.

6.7.4 - MAINTENANCE AND PERIODICAL CONTROLS

Regularly check the absence of grease coming from the leakage channel or from the lip seal (REF 106).

7 | STORAGE

7.1 - STORAGE OF THE PUMP

Store the pump in a sheltered and dry place and ensure that the storage room temperature is between -20°C (-4°F) and 45°C (113°F). Protect the pump if necessary and block the inlet and outlet orifices. If pump remains idle for over 1 month, remove the hose from the pump or remove one of the shoes as well as its centering pin and position the wheel so that the second shoe can be seen through the sight glass. For models ALH05, ALH10, ALH15 and ALH20 position the wheel so that one of the cam lobes remains submerged in the lubricant. If you can neither withdraw the hose or one of the shoes, run the pump 5 minutes a week.



ALH

Storage / Troubleshooting

7.2 - STORAGE OF THE PUMP HOSES

Hoses must be stored sheltered from light in a cool place. Their life is reduced after two years. The performance of hoses is reduced at the end of this expiration date due to the aging of rubber.

8 | TROUBLESHOOTING

PROBLEM	POSSIBLE REASON	RESOLUTION
The pump does not work	No power supply.	Check that the pump power switch is on position "ON".
		Check the connection of the motor.
	The wheel of the pump stalls.	Check the fixing of the hose.
		Check that the discharge pressure is not too high.
		Check that the product hasn't sedimentated in the hose.
The lubricant level detector has been operated.	Check the reason for which the level detector has been operated. Check the correct functioning of this one. If the pump hose has busted, undertake the replacement of the pump hose.	
Low capacity or pressure	Not enough shims under shoes.	Add the sufficient number of shims.
	Air leak at the inlet of the pump.	Check the tightening of the clamps of the pump and the sealing of the inlet piping.
	Valve closed or partly closed at inlet.	Fully open the valve.
	Wear of the hose.	Replace the hose.
	Product too viscous or the pump speed is too high compared to the product viscosity.	Ask for advice from your Albin distributor.
	Piping blocked or partly blocked at inlet.	Unblock piping at inlet and verify there is product flow that meets requirements.



ALH

Troubleshooting

8 | TROUBLESHOOTING

PROBLEM	POSSIBLE REASON	CORRECTION
Hose life is too short.	Incompatibility of the hose with the pumped product.	Make sure the compatibility of the hose with your product and contact your Albin distributor.
	Discharge pressure too high.	Check that the discharge pressure of the pump does not exceed 15 bar (217 psi) or 8 bar (116 psi) for ALH05 to ALH20). Check that the outlet piping is not blocked and that all valves are opened.
		Make sure that the security valve works correctly. Make sure that the piping friction losses do not exceed the value requested for an appropriate functioning of the pump.
	Pump speed too high.	Reduce the pump speed.
	Wrong shimming.	Check the shimming.
Too high temperature of the product.	Contact your Albin distributor.	
Lubricant leakage around the cover	Deficient tightening of cover bolts. Wear of the cover seal.	Tighten cover bolts. Replace cover seal.
Lubricant leakage visible in the designated leakage channel (underneath the gearbox flange)	Wear of the shaft seal or the seal ring.	Replace these parts.
Lubricant leakage at the sleeves	Deficient tightening of clamps or spoilt sleeve(s).	Tighten clamps or replace sleeves.
Pulsations in piping.	Deficient fastening of the piping.	Fix piping correctly.
	Process creating important pulsations due to the product, the speed of the pump, discharge pressure or the sizing of piping.	Contact your Albin distributor.
Grease leakage (ALHS series).	Worn lip seals	Replace the lip seals (REF 105) and (REF 106). See §6.4 and §6.6.
Abnormal noise coming from the bearing case (ALHS series).	Lack of lubricant in the bearing case. Worn bearings.	Refill the bearing case with appropriate grease. Replace bearings. See §6.4 and §6.6.



ALH

Characteristics / Technical Specifications

9 | CHARACTERISTICS AND TECHNICAL SPECIFICATIONS

9.1 - PERFORMANCE CURVES

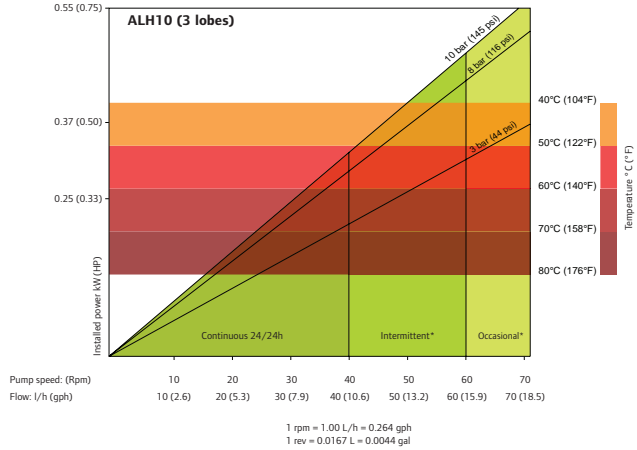
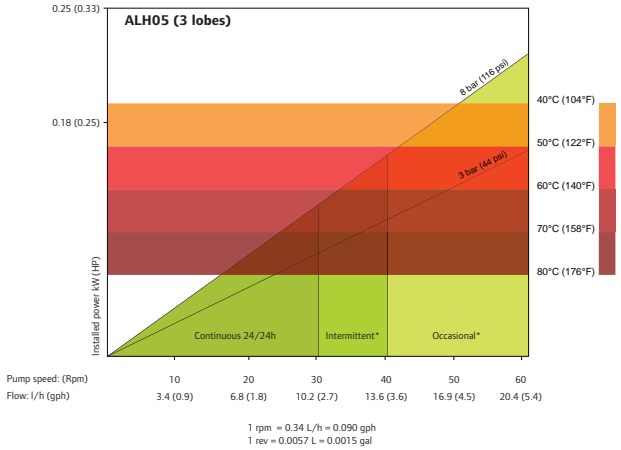

*Intermittent use : minimum one hour stop after 2 hours run / *Occasional use : maximum one hour a day

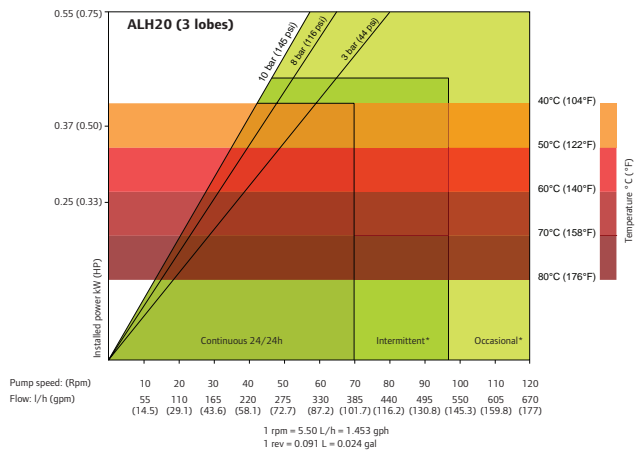
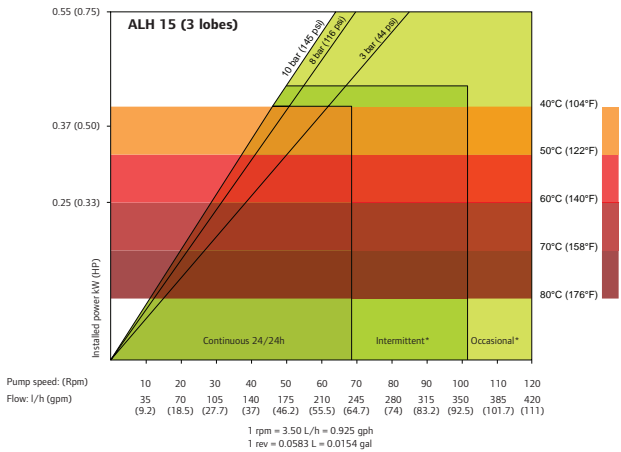
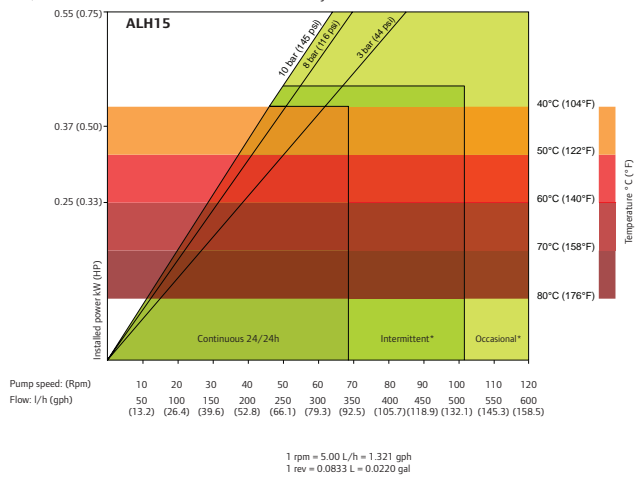
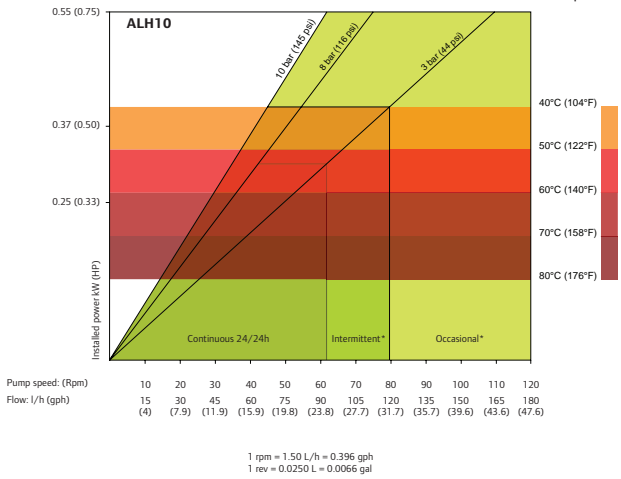

*Intermittent use : minimum one hour stop after 2 hours run / *Occasional use : maximum one hour a day



ALH

Characteristics / Technical Specifications

9 | CHARACTERISTICS AND TECHNICAL SPECIFICATIONS

9.1 - PERFORMANCE CURVES

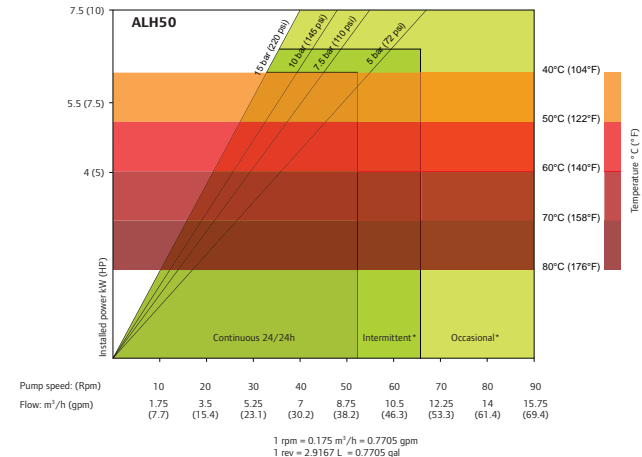
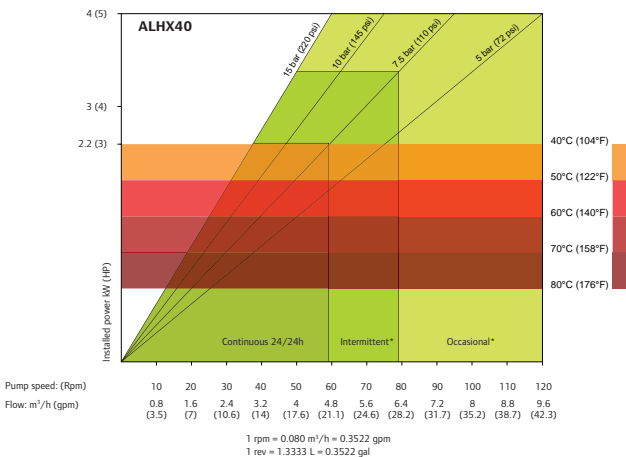
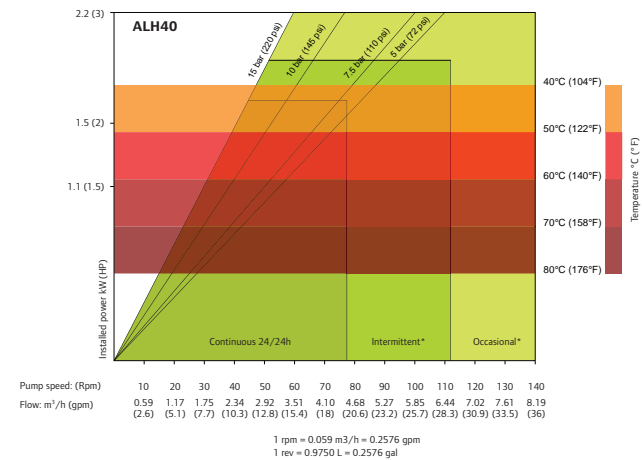
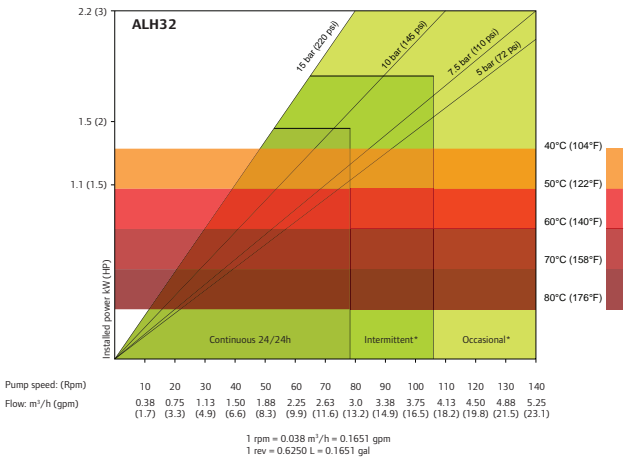
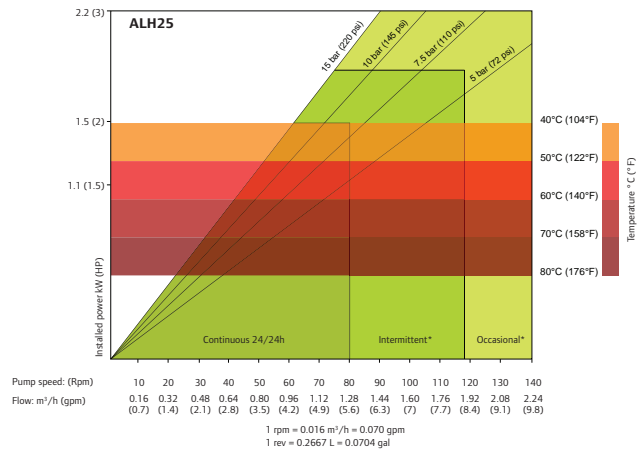
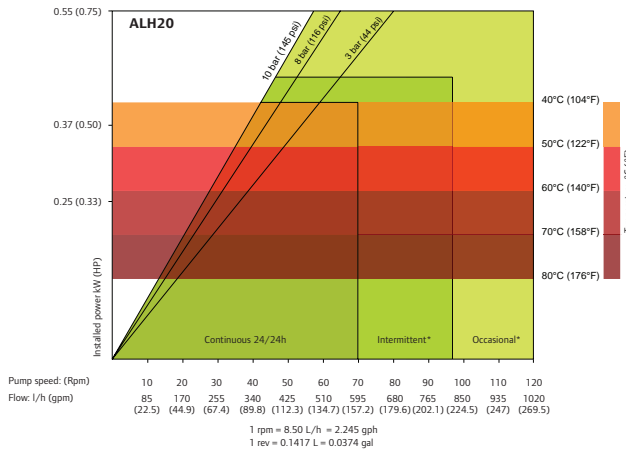

*Intermittent use : minimum one hour stop after 2 hours run / * Occasional use : maximum one hour a day



ALH

Characteristics / Technical Specifications

9 | CHARACTERISTICS AND TECHNICAL SPECIFICATIONS

9.1 - PERFORMANCE CURVES

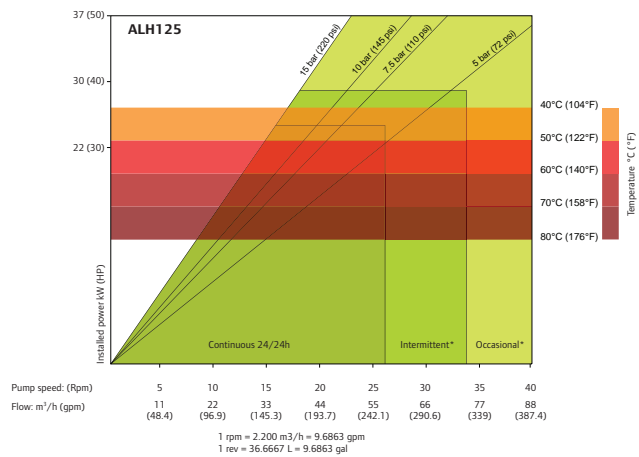
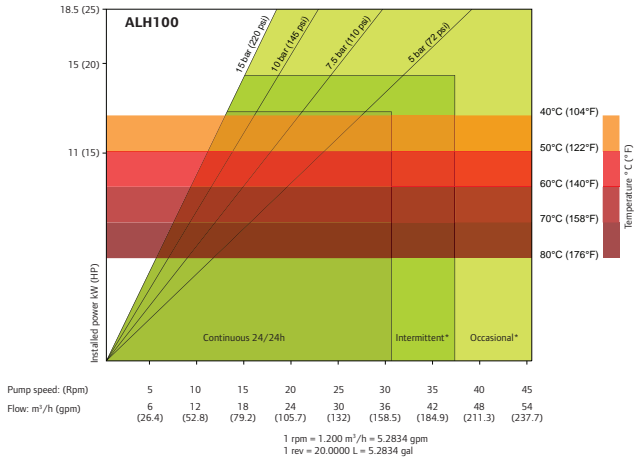
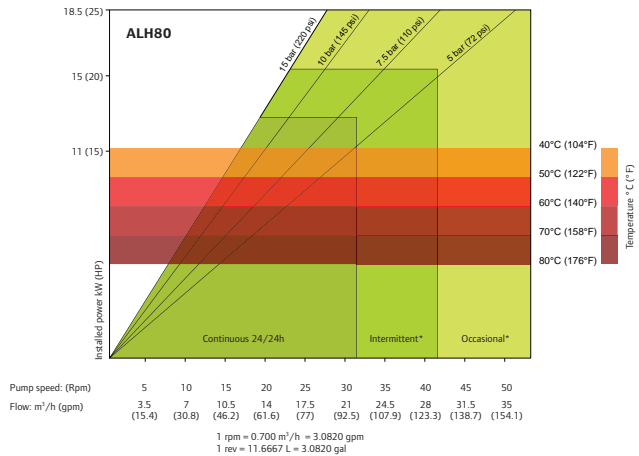
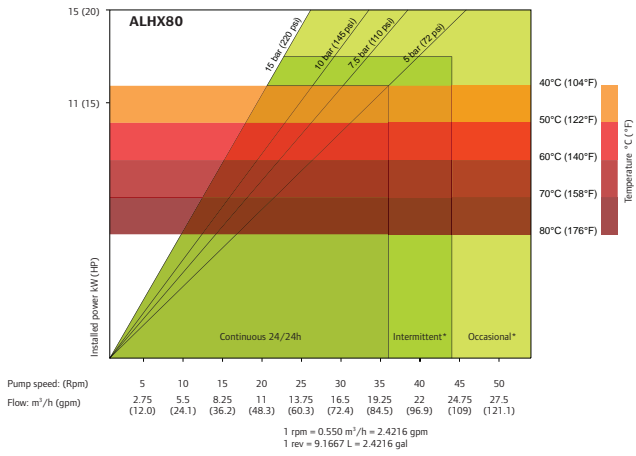
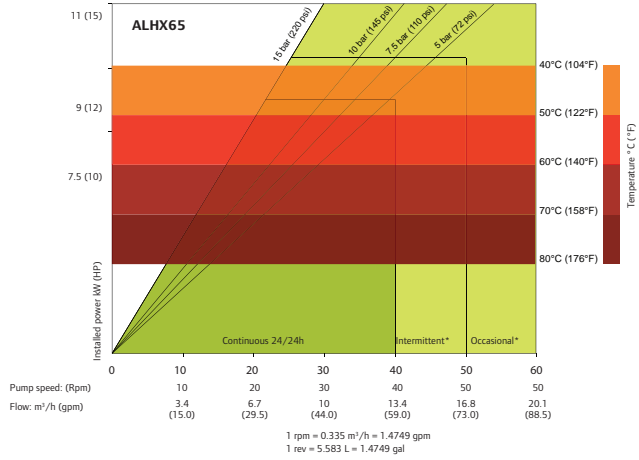
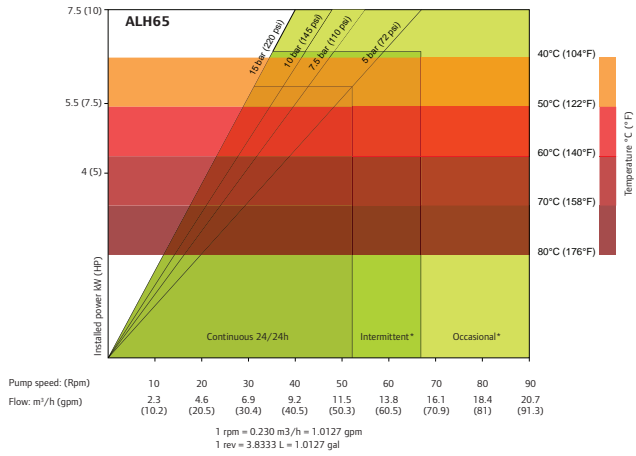

*Intermittent use : minimum one hour stop after 2 hours run / *Occasional use : maximum one hour a day



ALH

Characteristics / Technical Specifications

9.2 - ALBIN PUMP DIMENSIONS ALH05 TO ALH125 FLANGED GEAR MOTOR AND ALHS SERIES

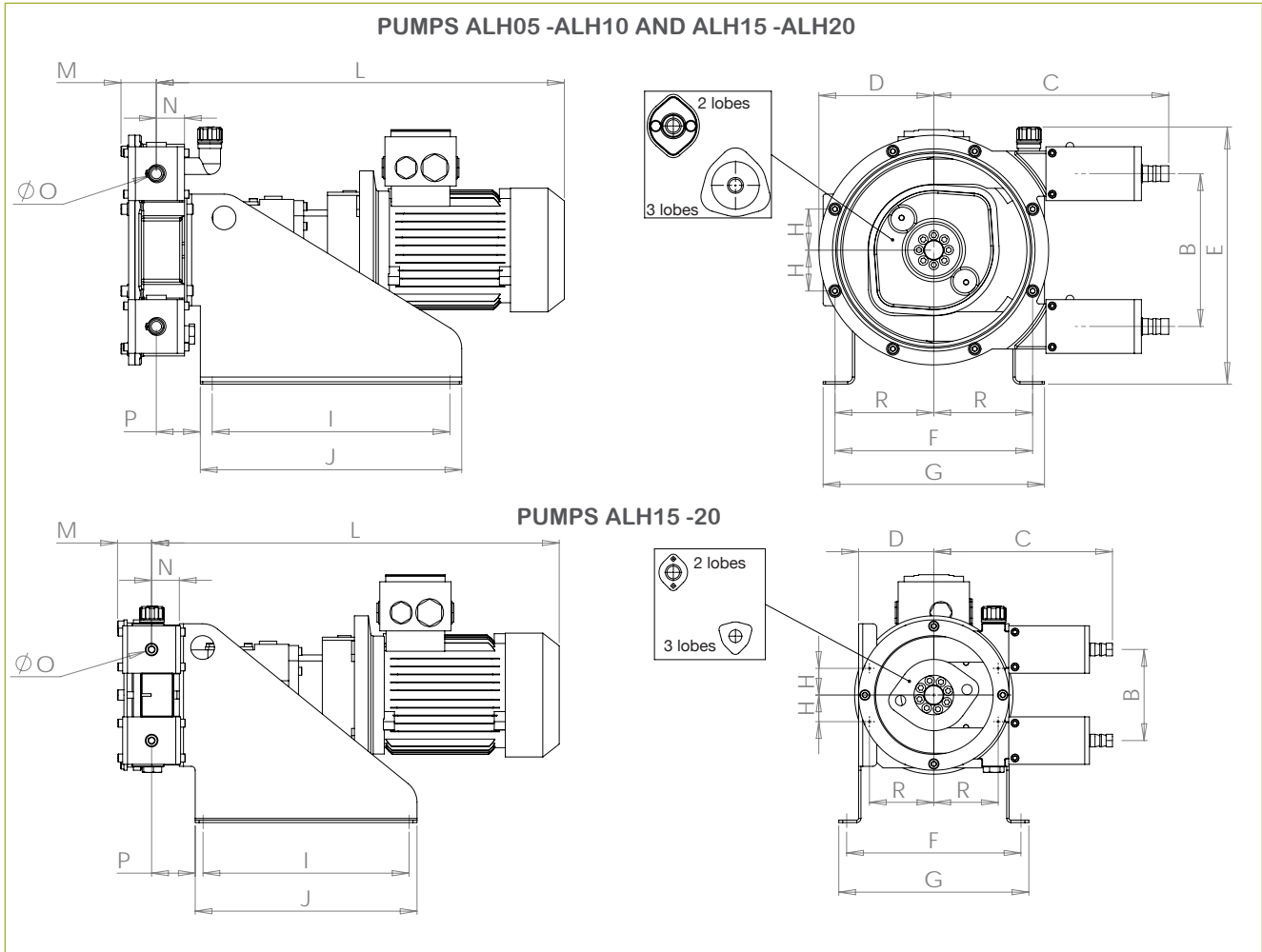

DIMENSIONS

mm (Inch)

	A	B	C	D	E	F	G	H	I	J
ALH05-ALH10	104 (4.0)	115 (4.5)	226 (8.9)	95 (3.7)	271 (10.7)	220 (8.7)	240 (9.4)	33.5 (1.3)	260 (10.2)	280 (11.0)
ALH15	73 (2.9)	193 (7.6)	297 (11.7)	145 (5.7)	325 (12.8)	249 (9.8)	280 (11.0)	52 (2.0)	300 (11.8)	330 (13.0)
ALH20	73 (2.9)	193 (7.6)	297 (11.7)	145 (5.7)	325 (12.8)	249 (9.8)	280 (11.0)	52 (2.0)	300 (11.8)	330 (13.0)

	K	L	M	N	ØO	P	R
ALH05-ALH10	4xø9 (4xø0.35)	-	42.5 (1.7)	36.5 (1.4)	16* (0.6)	66 (2.6)	81.3 (3.2)
ALH15	4xø13 (4xø0.5)	-	46 (1.8)	35.5 (1.4)	2* (0.7)	70.5 (2.8)	124.8 (4.9)
ALH20	4xø13 (4xø0.5)	-	46 (1.8)	35.5 (1.4)	25* (1.0)	70.5 (2.8)	124.8 (4.9)



ALH

Characteristics / Technical Specifications

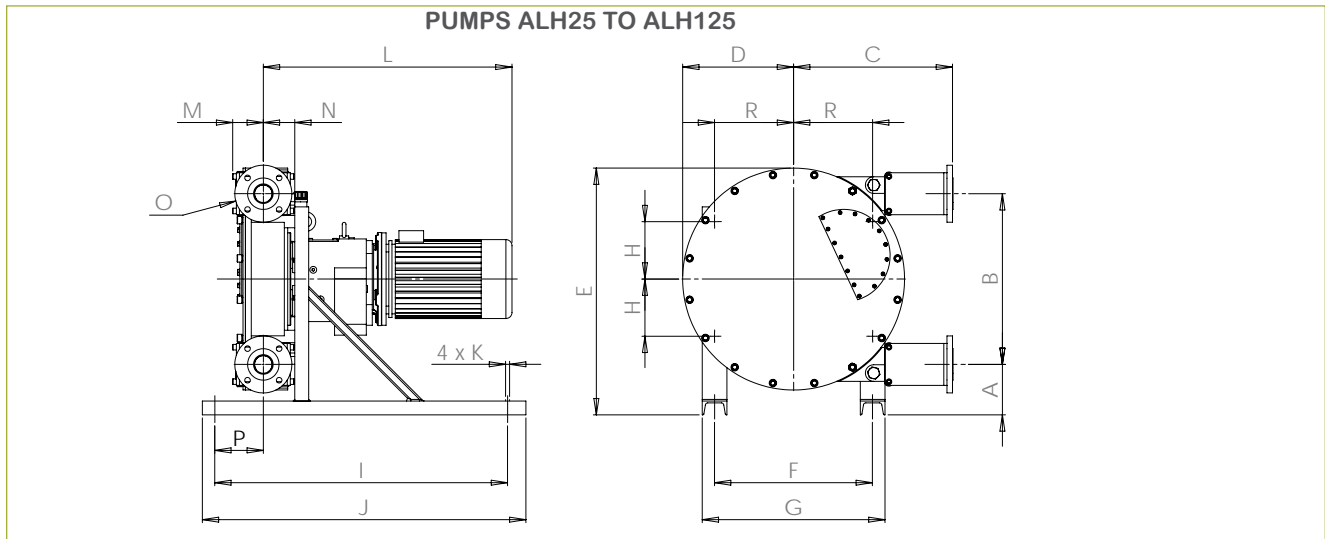

DIMENSIONS

mm (Inch)

	A	B	C	D	E	F	G	H	I	J
ALH25	95 (3.7)	262 (10.3)	356 (14.0)	134 (5.3)	430 (17)	307 (12.0)	347 (13.7)	110 (4.3)	520 (20.5)	550 (21.6)
ALH32	121 (4.8)	330 (13.0)	438 (17.2)	237 (9.3)	524 (20.6)	424 (16.7)	474 (18.7)	158 (6.2)	770 (30.3)	800 (31.5)
ALH40	121 (4.8)	330 (13.0)	438 (17.2)	237 (9.3)	524 (20.6)	424 (16.7)	474 (18.7)	158 (6.2)	770 (30.3)	800 (31.5)
ALHX40	110 (4.3)	430 (16.9)	414 (16.3)	294 (11.6)	619 (24.4)	340 (13.4)	420 (16.5)	159.4 (6.3)	850 (33.5)	950 (37.4)
ALH50	164 (6.4)	554 (21.8)	522 (20.5)	360 (14.2)	801 (31.5)	513 (20.2)	593 (23.3)	257 (10.1)	950 (37.4)	1050 (41.3)
ALHX65	143 (5.6)	597 (23.5)	598 (23.5)	390 (15.3)	831 (32.7)	513 (20.1)	593 (23.3)	186 (7.3)	950 (37.4)	1050 (41.3)
ALH65	164 (6.4)	554 (21.8)	522 (20.5)	360 (14.2)	801 (31.5)	513 (20.2)	593 (23.3)	257 (10.1)	950 (37.4)	1050 (41.3)
ALHX80	158 (6.2)	746 (29.4)	609 (24)	473 (18.6)	1004 (39.5)	580 (22.8)	680 (26.8)	290 (11.4)	1150 (45.2)	1250 (49.2)
ALH80	266 (10.5)	876 (34.5)	803 (31.6)	561 (22.0)	1265 (49.8)	690 (27.2)	830 (32.3)	345 (13.6)	1300 (51.2)	1400 (55.1)
ALH100	300 (11.8)	1040 (40.9)	911 (35.9)	698 (27.5)	1516 (59.7)	820 (32.3)	960 (37.8)	387 (15.2)	1900 (74.8)	2000 (78.7)
ALH125	258.5 (10.2)	1273 (50.1)	1037 (40.8)	818 (32.2)	1715 (67.5)	1000 (39.4)	1160 (45.7)	500 (19.7)	1900 (74.8)	2000 (78.7)

	K	L	M	N	O ANSI FLANGE / ISO FLANGE	P	R
ALH25	4xø13 (4xø0.5)	-	62 (2.4)	62 (2.4)	ANSI 1 in / 150# (DN25 PN16)	71 (2.8)	110 (4.3)
ALH32	4xø13 (4xø0.5)	-	85 (3.3)	75 (2.9)	ANSI 1.25 in / 150# (DN32 PN16)	91.5 (3.6)	158 (6.2)
ALH40	4xø13 (4xø0.5)	-	85 (3.3)	75 (2.9)	ANSI 1.5 in / 150# (DN40 PN16)	91.5 (3.6)	158 (6.2)
ALHX40	4xø19 (4xø0.7)	-	74 (2.9)	64 (2.5)	ANSI 1.5 in / 150# (DN40 PN16)	87 (3.4)	159.4 (6.3)
ALH50	4xø19 (4xø0.7)	-	99.5 (3.91)	87.6 (3.4)	ANSI 2 in / 150# (DN50 PN16)	148 (5.8)	186.5 (7.3)
ALHX65	4xø19 (4xø0.7)	-	113 (4.4)	113 (4.4)	ANSI 2.5 in / 150# (DN65 PN16)	136 (5.3)	256 (10.0)
ALH65	4xø19 (4xø0.7)	-	99.5 (3.91)	87.6 (3.4)	ANSI 2.5 in / 150# (DN65 PN16)	148 (5.8)	186.5 (7.3)
ALHX80	4xø19 (4xø0.7)	-	108 (4.2)	108 (4.2)	ANSI 3 in / 150# (DN80 PN16)	167 (6.6)	290 (11.4)
ALH80	4xø27 (4xø1.0)	-	125 (4.9)	108.5 (4.3)	ANSI 3 in / 150# (DN80 PN16)	202 (7.8)	345 (13.6)
ALH100	4xø27 (4xø1.0)	-	147 (5.8)	131 (5.1)	ANSI 4 in / 150# (DN100 PN16)	361 (14.2)	387 (15.2)
ALH125	4xø27 (4xø1.0)	-	160.5 (6.3)	144.5 (5.7)	ANSI 5 in / 150# (DN125 PN16)	363.5 (14.3)	500 (19.7)



ALH

Characteristics / Technical Specifications

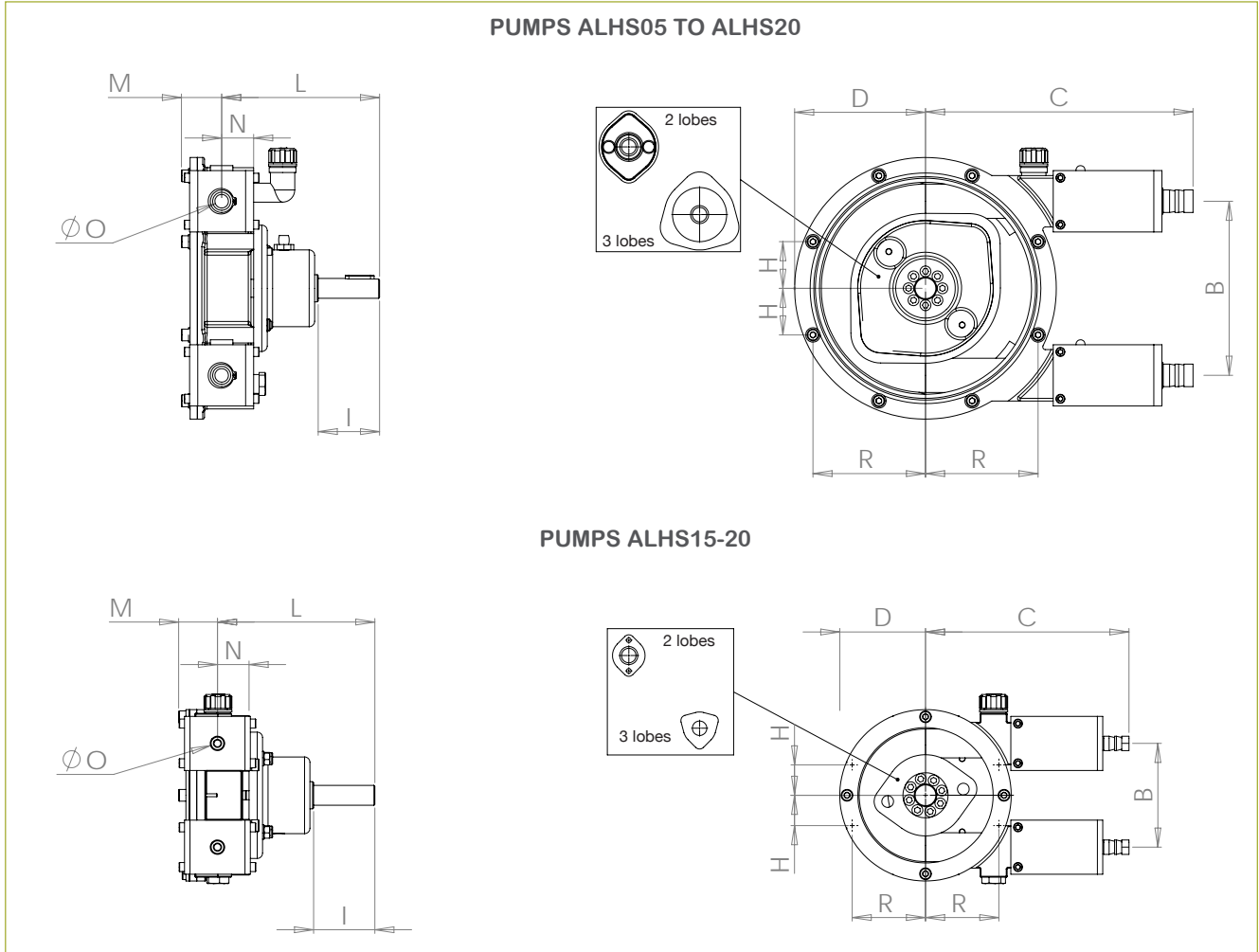

DIMENSIONS

mm (Inch)

	B	C	D	H	L	M	N	Connections	SHAFT		FRAME FASTENINGS	
								øO	R	I		DIAMETER
ALHS05 ALHS10	115 (4.5)	226 (8.9)	95 (3.7)	33.5 (1.3)	146 (5.7)	42.5 (1.7)	36.5 (1.4)	ø16 (ø0.6)	81.3 (3.2)	43 (1.7)	18k6	4xM8
ALHS15 ALHS20	193 (7.6)	297 (11.7)	145 (5.7)	52 (2.0)	175 (6.9)	46 (1.8)	35.5 (1.4)	ø20 (ø0.8) ø25 (ø1.0)	124.8 (4.9)	72 (2.8)	22k6	4xM8



ALH

Characteristics / Technical Specifications

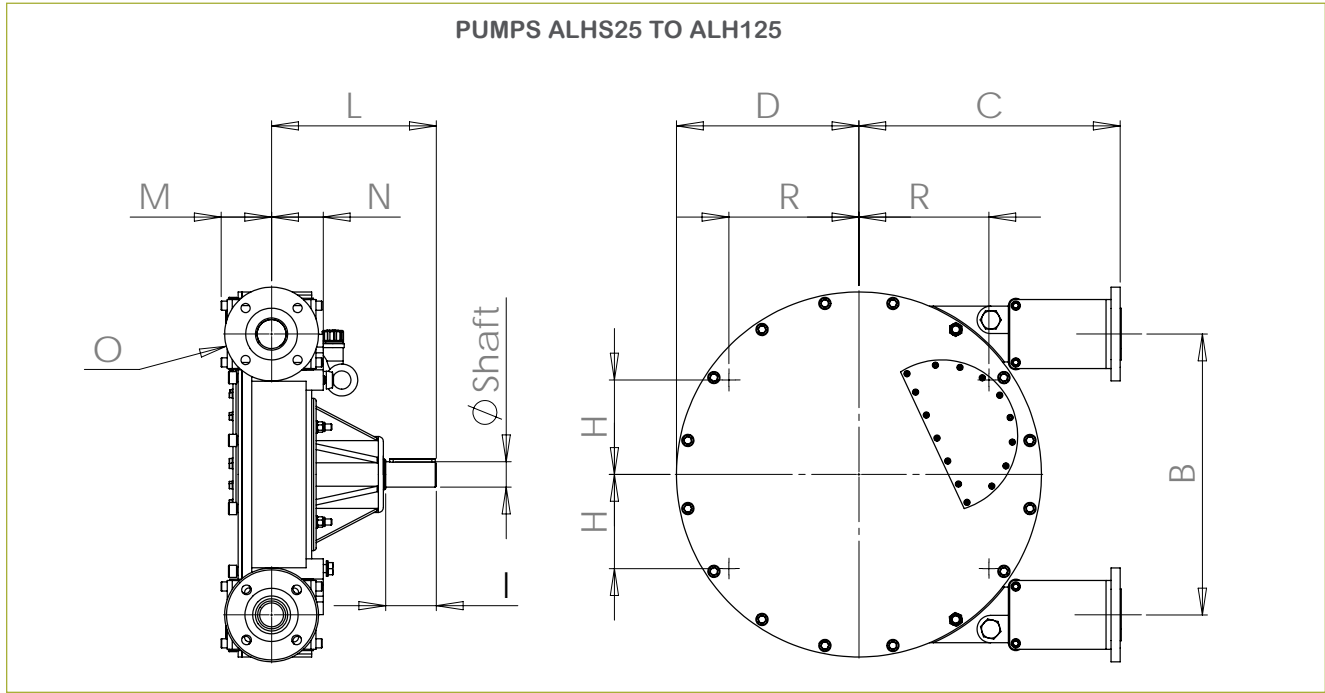

DIMENSIONS

mm (Inch)

	B	C	D	H	L	M	N	Connections	SHAFT		FRAME FASTENINGS	
								O ISO FLANGES	R	I		DIAMETER
ALHS25	262 (10.3)	356 (14.0)	134 (5.3)	110 (4.3)	192 (7.5)	62 (2.4)	62 (2.4)	ANSI 1 in / 150# (DN25 PN16)	110 (4.3)	63 (2.5)	30k6	4xM10
ALHS32 ALHS40	330 (13.0)	438 (17.2)	237 (9.3)	158 (6.2)	263 (10.3)	85 (3.3)	75 (2.9)	ANSI 1.25 in / 150# (DN32 PN16) ANSI 1.5 in / 150# (DN40 PN16)	158 (6.2)	92 (3.6)	40k6	4xM12
ALHSX40	430 (16.9)	414 (16.3)	294 (11.6)	159.4 (6.3)	260 (10.2)	74 (2.9)	64 (2.5)	ANSI 1.5 in / 150# (DN40 PN16)	159.4 (6.3)	102.5 (4.0)	40k6	4xM12
ALHS50 ALHS65	554 (21.8)	522 (20.5)	360 (14.1)	257 (10.1)	325 (12.8)	99.5 (3.9)	87.6 (3.4)	ANSI 2 in / 150# (DN50 PN16) ANSI 2.5 in / 150# (DN65 PN16)	186.5 (7.3)	104.5 (4.1)	50k6	4xM16
ALHSX65	N/A	N/A	N/A	N/A	N/A	N/A	N/A	N/A	N/A	N/A	N/A	N/A
ALHSX80	746 (29.3)	609 (24.0)	473 (18.6)	290 (11.4)	395.4 (15.6)	108 (4.2)	108 (4.2)	ANSI 3 in / 150# (DN80 PN16)	167 (6.6)	131.4 (5.2)	70k6	4xM20
ALHS80	876 (34.5)	803 (31.6)	561 (22.0)	345 (13.6)	387.4 (15.2)	125 (4.9)	108.5 (4.3)	ANSI 3 in / 150# (DN80 PN16)	345 (13.6)	131.4 (5.3)	80k6	4xM20
ALHS100	1040 (40.9)	911 (35.6)	698 (27.5)	387 (15.2)	530 (20.9)	147 (5.8)	131 (5.1)	ANSI 4 in / 150# (DN100 PN16)	387 (15.2)	153 (6.0)	100k6	4xM20
ALHS125	1273 (50.1)	1037 (40.8)	818 (32.2)	500 (19.7)	606 (23.8)	160.5 (6.3)	144.5 (5.7)	ANSI 5 in / 150# (DN125 PN16)	500 (19.7)	216 (8.5)	120k6	4xM24



ALH

Characteristics / Technical Specifications

9.3 - NOMENCLATURE

Ce document est la propriété de Albin Pump AB. Toute reproduction interdite sans autorisation expresse de Albin Pump AB.

Exploded view ALH05 - ALH10

**ALH05-10
EXPLODED VUE**

MATERIAL:	WEIGHT:	CUSTOMER:	PRIM TYPE: ALH05-10	Code Origin:	Serial number:
BRUT:	NET:	PROJECT N°:	PART NUMBER	 ALBIN PUMP AB ÅKERFORSKAT 1 431 50 MÖLNÄS, SWEDEN	
DM:	CHARGE: +/-	REP	REP		
TITLE:				SIZE: A3	
SCALE: 1:				REV: 1	
DWG N°: EXPLODE ALH05-10 IND01 10/2011					

Wheel #3
3 lobe version

REFER TO ALH PUMP PARTS LIST FOR PART DESIGNATION



ALH

Characteristics / Technical Specifications

9.3 - NOMENCLATURE

Ce document est la propriété de Albin Pump AB. Toute reproduction interdite sauf autorisation expresse de Albin Pump AB.

Exploded view ALH15 - ALH20

**ALH15-20
EXPLODED VUE**

MATERIAL:	WEIGHT:	CUSTOMER:	PUMP TYPE: ALH15-20	Code Oratio: Serial number:	 ALBIN PUMP AB Ålegårdsplan 1 431 50 Möneda SWEDEN
BRUT:	General clearance: +/-	PROJECT N°:	PART NUMBER: REP:		
TITLE:		ALH15-20 EXPLODED VUE		SIZE: A3	REV: 1
SCALE: 1:		DWG N°: EXPLODE ALH15-20 IND01 10-2011			

Wheel #3
3 lobe version

REFER TO ALH PUMP PARTS LIST FOR PART DESIGNATION



ALH

Characteristics / Technical Specifications

9.3 - NOMENCLATURE

Ce document est la propriété de Albin Pump AB. Toute reproduction interdite sans autorisation expresse de Albin Pump AB.

Exploded view ALH25 - ALH40

DETAIL B

DETAIL A

REFER TO ALH PUMP PARTS LIST FOR PART DESIGNATION

MATERIAL:	WEIGHT:	CUSTOMER:	PUMP TYPE: ALH25-32-40	Code/Oratio:	Serial number:
NS:	GENERAL CLEARANCE:	PROJECT N°:	PART NUMBER:	ALBIN PUMP AB ÅKERSTRAKAT 1 431 50 MORA DAL, SWEDEN	
BRUT:	DIM:	REP:			
TITLE:					
EXPLODED VIEW ALH25-32-40				SCALE: 1:	DWG N°: EXPLODE ALH25-32-40 IN001 11-2010
				SIZE: A3	REV: 1



9.3 - NOMENCLATURE

Ce document est la propriété de Albin Pump AB. Toute reproduction interdite sauf autorisation expresse de Albin Pump AB.

Exploded view ALHX65

MATERIAL: MSMateriële <non specific>	CUSTOMER:	PUMP TYPE: ALHX65	Code Oratio: Serial number:
TBRU:	PROJECT N°:	PART NUMBER: HX65XXXXXXBA00A	 ALBIN PUMP AB 431 50 MÖRDSVÄDEN SWEDEN
DM:	+ / -	TITLE:	
ALHX65 EXPLODED VIEW			SIZE: A3
SCALE: 1:			REV: 1
DWG N°: EXPLODE ALHX65 IND01 6.2021			

REFER TO ALH PUMP PARTS LIST FOR PART DESIGNATION!



ALH

Characteristics / Technical Specifications

9.3 - NOMENCLATURE

**Exploded view
ALHX80 - ALH80**

DETAIL C

DETAIL B

DETAIL A

REFER TO ALH PUMP PARTS LIST FOR PART DESIGNATION.

* For ALH80 pumps only with a \varnothing 350/400/450 gear box angle dimension.

** For ALHX80 pump only.

Lifting ring on ALH80 cover.

MATERIAL: Materiële \varnothing nom. spec. \varnothing *	WEIGHT:	CUSTOMER:	PUMP TYPE: ALHX80-80	Code Oratio: Serial number:	
BRUTE:	General clearance: +/-	PROJECT N°:	PART NUMBER		
DM:			REP		
<p>ALHX80-80 EXPLODED VIEW</p>					
TITLE:				<p>ALBIN PUMP AB Albinvägen 10 431 30 Mölndal SWEDEN</p>	
SCALE: 1:	DMG N°: EXPLODE ALHX80-80 IND01 11-2010	SIZE: A3	REV: 1		

Ce document est la propriété de Albin Pump AB. Toute reproduction interdite sans autorisation expresse de Albin Pump AB.



ALH

Characteristics / Technical Specifications

9.3 - NOMENCLATURE

Ce document est la propriété de Albin Pump AB. Toute reproduction interdite sauf autorisation expresse de Albin Pump AB.

Exploded view ALH100

REFER TO ALH PUMP PARTS LIST FOR PART DESIGNATION

MATERIAL: Matériau «non-spécifié»	WEIGHT: General clearance: +/-	CUSTOMER: PROJECT N°:	PUMP TYPE: ALH100 PART NUMBER	Code Oratio: Serial number:
BRUT:	DM:	TITLE:	 ALH100 EXPLODED VIEW	
SCALE: 1:			DWG N°: EXPLODE ALH100 IND01 11-2010	SIZE: A3
				REV.: 1



ALH

Characteristics / Technical Specifications

9.3 - NOMENCLATURE

Ce document est la propriété de Albin Pump AB. Toute reproduction interdite sans autorisation expresse de Albin Pump AB.

**ALH125
EXPLODED VIEW**

**Exploded view
ALH125**

DETAIL C

DETAIL A

DETAIL B

REFER TO ALH PUMP PARTS LIST FOR PART DESIGNATION

MATERIAL: Materiåll <non speci f>		WEIGHT: General clearance: - / -		CUSTOMER: PROJECT N°:		PUMP TYPE: ALH125		Code Oratio: Serial number:	
BRUT: DIM:						PART NUMBER REP:		 ALBIN PUMPFAB Ålmgångsgatan 1 431 30 Nordal SWEDEN	
TITLE:									
SCALE: 1:		DWG N°: EXPLODE ALH125 IND001 11-2010		SEE: A3		REV: 1			



ALH

Characteristics / Technical Specifications

9.3 - NOMENCLATURE

Ce document est la propriété de Albin Pump AB. Toute reproduction interdite sauf autorisation expresse de Albin Pump AB.

**Exploded view
ALHS05 - ALHS125 Bearing Case**

DETAIL ALHSX80 to ALHS125

MATERIAL: Matériau - non-spéc. é>	WEIGHT: General clearance: +/-	CUSTOMER:	PUMP TYPE: ALHS05 to S125	Code Origin: Serial number:	 ALBIN PUMP AB ALBINPUMPS 431 50 ÅRNHOLM SWEDEN
BRUT:	DM:	PROJECT N°:	PART NUMBER: REP	SIZE: A3	
TITLE: EXPLODED VIEW ALHS BEARING CASE				REV: 1	
SCALE: 1:				DWG N°: EXPL.ODE.ALHS05-125.BEARING CASE.IND01.12.2010	



ALH

Characteristics / Technical Specifications

9.3 - NOMENCLATURE

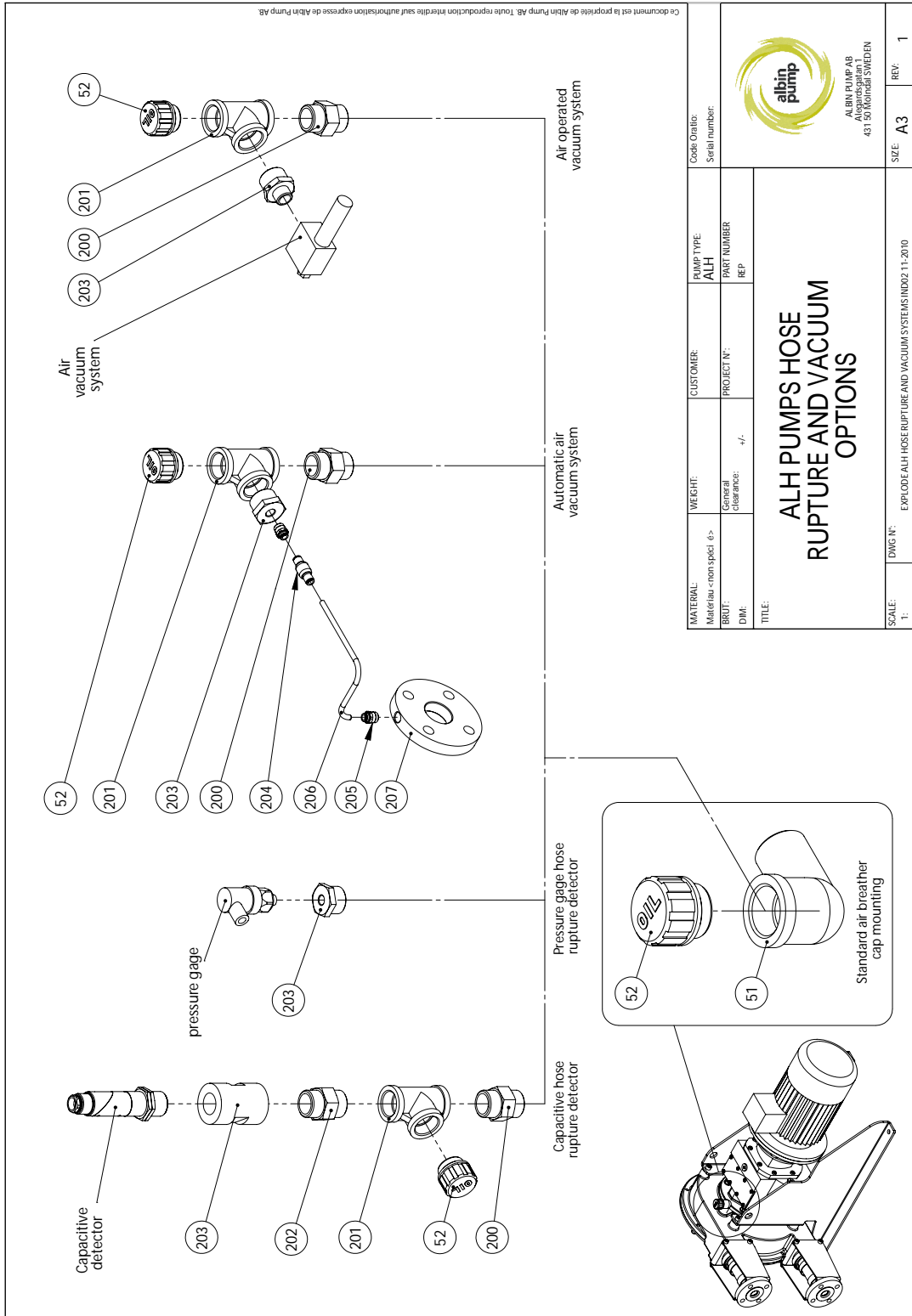



ALH

Characteristics / Technical Specifications

9.4 - ALH PUMP PARTS LIST (see specific exploded view)

REF.	DESIGNATION	ALH 05 (3 LOBES)	ALH10	ALH10 (3 LOBES)	ALH15	ALH15 (3 LOBES)	ALH20	ALH20 (3 LOBES)	ALH25	ALH32	ALH40
1	CASING	ALH100110	ALH100110	ALH100110	ALH150110	ALH150110	ALH150110	ALH150110	ALH250110	ALH320110	ALH320110
2	COVER	ALH100200	ALH100200	ALH100200	ALH150201	ALH150201	ALH150201	ALH150201	ALH250200	ALH320200	ALH320200
3	WHEEL	ALH050310	ALH100310	ALH100303	ALH150310	ALH150330	ALH200310	ALH200340	ALH250310	ALH320310	ALH320310
4	SHIM								ALH250400	ALH320400	ALH320400
5	SHOE CAST IRON								ALH250530	ALH320530	ALH400530
5	SHOE PPH								ALH250540	ALH320550	ALH400550
6	SLEEVE	ALH100600	ALH100600	ALH100600	ALH150600	ALH150600	ALH150600	ALH150600	ALH250600	ALH320600	ALH320600
7	CLAMP SLEEVE	ALHCL3250	ALHCL3250	ALHCL3250	ALHCL5070	ALHCL5070	ALHCL5070	ALHCL5070	ALHCL7090	ALHCL7090	ALHCL7090
8	CLAMP ON SLEEVE / HOSE	ALHCL3639	ALHCL3639	ALHCL3639	ALHCL4043	ALHCL4043	ALHCL4043	ALHCL4043	ALHCL6063	ALHCL6873	ALHCL6873
9	CLAMP ON HOSE	ALHCL3235	ALHCL3235	ALHCL3235	ALHCL3639	ALHCL3639	ALHCL3639	ALHCL3639	ALHSL602N	ALHSL602N	ALHSL602N
10	COVER SEAL	ALHCO03485	ALHCO03485	ALHCO03485	ALHCO3.5780	ALHCO3.5780	ALHCO3.5780	ALHCO3.5780	ALHCO61050	ALHCO61335	ALHCO61335
12	INSERT SS	ALH051203-00-16	ALH101203-00-16	ALH101203-00-16	ALH151203-00-20	ALH151203-00-20	ALH201203-00-25	ALH201203-00-25	ALH251200	ALH321200	ALH401200
12	INSERT PPH	ALH051204-00-16	ALH101204-00-16	ALH101204-00-16	ALH151204-00-20	ALH151204-00-20	ALH201204-00-25	ALH201204-00-25	ALH251210	ALH321210	ALH401210
12	INSERT PVDf	ALH051218-00-16	ALH101218-00-16	ALH101218-00-16	ALH151218-00-20	ALH151218-00-20	ALH201218-00-25	ALH201218-00-25	ALH251220	ALH321220	ALH401220
14	LUBRICANT	REF. TO LUBRICANT QTY	REF. TO LUBRICANT QTY	REF. TO LUBRICANT QTY	REF. TO LUBRICANT QTY	REF. TO LUBRICANT QTY	REF. TO LUBRICANT QTY	REF. TO LUBRICANT QTY	REF. TO LUBRICANT QTY	REF. TO LUBRICANT QTY	REF. TO LUBRICANT QTY
15	SIGHT GLASS								ALH251500	ALH321500	ALH321500
16	HOSE	REFER TO HOSE MATERIAL	REFER TO HOSE MATERIAL	REFER TO HOSE MATERIAL	REFER TO HOSE MATERIAL	REFER TO HOSE MATERIAL	REFER TO HOSE MATERIAL	REFER TO HOSE MATERIAL	REFER TO HOSE MATERIAL	REFER TO HOSE MATERIAL	REFER TO HOSE MATERIAL
18	BRACKET GALV CS	ALH101801	ALH101801	ALH101801	ALH151801	ALH151801	ALH201801	ALH201801			
18	BRACKET SS	ALH101800	ALH101800	ALH101800	ALH151800	ALH151800	ALH201800	ALH201800			
18	ANSI/DIN BRACKET GALV CS								ALH251801-00-LG	ALH321801-00-LG	ALH401801-00-LG
18	ANSI/DIN BRACKET SS 304								ALH251802-00-LG	ALH321802-00-LG	ALH401802-00-LG
18	ANSI/DIN BRACKET SS 316	ON DEMAND	ON DEMAND	ON DEMAND	ON DEMAND	ON DEMAND	ON DEMAND	ON DEMAND			
19	HUB	ALHHU2550	ALHHU2550	ALHHU2550	ALHHU2550	ALHHU2550	ALHHU2550	ALHHU2550	ALHHU4065	ALHHU4065	ALHHU4065
20	BOLT ON PLATE										
21	FRAME CS L	ALH102101L	ALH102101L	ALH102101L	ALH152101L	ALH152101L	ALH152101L	ALH152101L	ALH252100L	ALH322100L	ALH322100L
21	FRAME CS R	ALH102101R	ALH102101R	ALH102101R	ALH152101R	ALH152101R	ALH152101R	ALH152101R	ALH252100R	ALH322100R	ALH322100R
21	FRAME SS L	ALH102100L	ALH102100L	ALH102100L	ALH152100L	ALH152100L	ALH152100L	ALH152100L	ALH252100L	ALH322100L	ALH322100L
21	FRAME SS R	ALH102100R	ALH102100R	ALH102100R	ALH152100R	ALH152100R	ALH152100R	ALH152100R	ALH252100R	ALH322100R	ALH322100R
21	COMPLETE FRAME										
22	LIFT RING										
23	OIL PLUG	ALHPL12GSS	ALHPL12GSS	ALHPL12GSS	ALHPL12GSS	ALHPL12GSS	ALHPL12GSS	ALHPL12GSS	ALHPL12GSS	ALHPL12GSS	ALHPL12GSS
24	CIRCLIPS	ALH102400	ALH102400	ALH102400	ALH152400	ALH152400	ALH202400	ALH202400			
25	SEAL FLANGE										
26	SHAFT SEAL	ALHSH3062	ALHSH3062	ALHSH3062	ALHSH3062	ALHSH3062	ALHSH3062	ALHSH3062	ALHSH4560	ALHSH4580	ALHSH4580
27	SEAL RING	ALHSE2530	ALHSE2530	ALHSE2530	ALHSE2530	ALHSE2530	ALHSE2530	ALHSE2530	ALHSE4045	ALHSE4045	ALHSE4045
28	SHOE BOLT								SC1030HSS	SC1235HSS	SC1235HSS
29	SHOE BOLT WASHER								WAMW102N	WAMW122N	WAMW122N
30	SHOE CENTERING PIN								ALHST0820	ALHST0820	ALHST0820
31	BOLT ON PLATE SCREW										
32	NUT FOR REF 31										
33	COVER BOLT	SC0820CSS	SC0820CSS	SC0820CSS	SC0820CSS	SC0820CSS	SC0820CSS	SC0820CSS	SC1020CSS	SC1225CSS	SC1225CSS
34	COVER BOLT WASHER										
35	COVER STUD										
36	NUT FOR REF 35										
37	SIGHT GLASS BOLT								SC0620CSS	SC0620CSS	SC0620CSS
38	WASHER FOR REF 37								WAM06ZSS	WAM06ZSS	WAM06ZSS
39	FRAME BOLT	SC0816CSS	SC0816CSS	SC0816CSS	SC0816CSS	SC0816CSS	SC0816CSS	SC0816CSS	SC1020CSS	SC1220CSS	SC1220CSS
40	WASHER FOR REF 39										
41	GEARBOX STUD	GUD939M0825	GUD939M0825	GUD939M0825	GUD939M0825	GUD939M0825	GUD939M0825	GUD939M0825	GUD939M1030	GUD939M1235-304	GUD939M1235-304
42	NUT FOR REF 41	NU08NYZN	NU08NYZN	NU08NYZN	NU08NYZN	NU08NYZN	NU08NYZN	NU08NYZN	NU10NYZN	NU12NYSS	NU12NYSS
43	SEAL FLANGE BOLT										
46	SIGHT GLASS SEAL								ALH254600	ALH324600	ALH324600
47	INLET & OULET FLANGE DIN	ON DEMAND	ON DEMAND	ON DEMAND	ON DEMAND	ON DEMAND	ON DEMAND	ON DEMAND	ALH254700	ALH324700	ALH404700
47	INLET & OULET FLANGE ANSI	ON DEMAND	ON DEMAND	ON DEMAND	ON DEMAND	ON DEMAND	ON DEMAND	ON DEMAND	ALH254720	ALH324720	ALH404720
48	BRACKET BOLT	SC0612CSS	SC0612CSS	SC0612CSS	SC0612CSS	SC0612CSS	SC0612CSS	SC0612CSS	SC0816CSS	SC1016CSS	SC1016CSS
49	BRACKET BOLT WASHER										
51	90° BEND				ALHBEMF12SS	ALHBEMF12SS	ALHBEMF12SS	ALHBEMF12SS	ALHBEMF12SS	ALHBEMF34SS	ALHBEMF34SS



ALH

Characteristics / Technical Specifications

9.4 - ALH PUMP PARTS LIST (see specific exploded view)

REF.	DESIGNATION	ALH 05 (3 LOBES)	ALH10	ALH10 (3 LOBES)	ALH15	ALH15 (3 LOBES)	ALH20	ALH20 (3 LOBES)	ALH25	ALH32	ALH40
52	BREATHER PLUG	ALHPV12	ALHPV12	ALHPV12	ALHPV12	ALHPV12	ALHPV12	ALHPV12	ALHPV12	ALHPV34	ALHPV34
59	WHEEL BOLT WASHER										
60	WHEEL BOLT										
63	LIFT RING ON COVER										
64	BOLT for REF 63										
67	O RING FOR SEAL FLANGE										
70	GEARBOX CENTRING FLANGE										
71	COVER FLANGE	ALH107101	ALH107101	ALH107101	ALH157103	ALH157103	ALH157103	ALH157103			
72	WASHER for REF 41	WAM08ZSS	WAM08ZSS	WAM08ZSS	WAM08ZSS	WAM08ZSS	WAM08ZSS	WAM08ZSS	WAM10ZSS	WAM12ZSS	WAM12ZSS
73	SPACER RING										
74	PLUG								ALHPL12GSS	ALHPL34GSS	ALHPL34GSS
75	O-RING FOR 73										
76	SPACER RING (ALH125 ONLY)										
77	WASHER FOR 59										
78	WASHER FOR LIFT RING 63										
79	NUT										
80	WASHER										
81	GUDGEON										
82	SILENT BLOC										
83	WASHER										
84	NUT										

REF.	DESIGNATION	ALHX40	ALH50	ALH65	ALHX65	ALHX80	ALH80	ALH100	ALH125
1	CASING	ALHX400117-00-00	ALH650117-00-STD	ALH650117-00-STD	ALHX650117-00-STD	ALHX800111	ALH800110	ALH1000110	ALH1250110
2	COVER	ALHX400211	ALH650211	ALH650211	ALHX650201-00-00	ALHX800200	ALH800210	ALH1000211	ALH1250210
3	WHEEL	ALHX400310	ALH650310	ALH650310	ALHX650317-00-00	ALHX800311	ALH800310	ALH1000310	ALH1250310
4	SHIM	ALHX400400	ALH650400	ALH650400	ALHX650402-00-00	ALHX800400	ALH800400	ALH1000400	ALH1250400
5	SHOE CAST IRON	ALHX400530	ALH500530	ALH650530	ALHX650517-00-00	ALHX800540	ALH800530	ALH1000540	ALH1250530
5	SHOE PPH				ALHX650517-00-00				
6	SLEEVE	ALHX400600	ALH500600	ALH650600	ALHX650620-00-00	ALHX800600	ALH800600	ALH1000600	ALH1250600
7	CLAMP SLEEVE	ALHCL7090	ALHCL100120	ALHCL100120	ALHCL110130	ALHCL120140	ALHCL150170	-	-
8	CLAMP ON SLEEVE / HOSE	ALHCL7479	ALHCL8891	ALHCL9297	38409	ALHCL122130	ALHCL122130	ALHCL162174	ALHCL175187
9	CLAMP ON HOSE	ALHSL72ZN	ALHSL94ZN	ALHSL94ZN	ALHSL400ZN	ALHSL115ZN	ALHSL145ZN	ALHSL145ZN	ALHSL675ZN
10	COVER SEAL	ALHCO61620	ALHCO62048	ALHCO62048	ALHCO62236	ALHCO62720	ALHCO63235	ALHCO63800	ALHCO64800
12	INSERT SS	ALHX401200	ALH501200	ALH651200	ALHX651200	ALH801200	ALH801200	ALH1001200	ALH1251200
12	INSERT PPH	ALHX401210	ALH501210	ALH651210	ALHX651210	ALH801210	ALH801210	ALH1001210	ALH1251210
12	INSERT PVDf	ALHX401220	ALH501220	ALH651220	ALHX651220	ALH801220	ALH801220		
14	LUBRICANT	REF. TO LUBRICANT QTY	REF. TO LUBRICANT QTY	REF. TO LUBRICANT QTY	REF. TO LUBRICANT QTY	REF. TO LUBRICANT QTY	REF. TO LUBRICANT QTY	REF. TO LUBRICANT QTY	REF. TO LUBRICANT QTY
15	SIGHT GLASS	ALHX401500	ALH651500	ALH651500	ALH651500	ALH801500	ALH801500	ALH1001500	ALH1001500
16	HOSE	REFER TO HOSE MATERIAL	REFER TO HOSE MATERIAL	REFER TO HOSE MATERIAL	REFER TO HOSE MATERIAL	REFER TO HOSE MATERIAL	REFER TO HOSE MATERIAL	REFER TO HOSE MATERIAL	REFER TO HOSE MATERIAL
18	BRACKET GALV CS								
18	BRACKET SS								
18	ANSI/DIN BRACKET GALV CS	ALHX401801-00-LG	ALH501801-00-LG	ALH651801-00-LG		ALHX801801-00-LG	ALH801801-00-LG	ALH1001801-00-LG	ALH1251801-00-LG
18	ANSI/DIN BRACKET SS 304	ALHX401802-00-LG	ALH501802-00-LG	ALH651802-00-LG	ALHX651802-01-LG	ALHX801802-00-LG	ALH801802-00-LG	ALH1001802-00-LG	ALH1251802-00-LG
18	ANSI/DIN BRACKET SS 316						ALH801820		
19	HUB	ALHHU5080	ALHHU6090	ALHHU6090	ALHHU302060	ALHHU3353590	ALHHU3353590		
20	BOLT ON PLATE				ALHBO1960	ALHBO1990	ALHBO1990		
21	FRAME CS L				ALH652100				
21	FRAME CS R				ALH652100				
21	FRAME SS L				ALH652100				
21	FRAME SS R				ALH652100				
21	COMPLETE FRAME	ALHX402100	ALH652100	ALH652100	ALH652100	ALHX802100	ALH802100	ALH1002100	ALH1252110
22	LIFT RING	ALHEYM12	ALHEYM16ZN	ALHEYM16ZN	ALHEYM16ZN	ALHEYM20	ALHEYM20	ALHEYM24ZN	ALHEYM24ZN
23	OIL PLUG	ALHPL34GSS	ALHPL1GSS	ALHPL1GSS	ALHPL1GSS	ALHPL1GSS	ALHPL1GSS	ALHPL1GSS	ALHPL112GSS
24	CIRCLIPS								
25	SEAL FLANGE				ALH802501-00-00	ALH802501-00-00	ALH802501-00-00	ALH802501-00-00	ALH1252501-BA120



ALH

Characteristics / Technical Specifications

9.4 - ALH PUMP PARTS LIST (see specific exploded view)

REF.	DESIGNATION	ALHX40	ALH50	ALH65	ALHX65	ALHX80	ALH80	ALH100	ALH125
26	SHAFT SEAL	ALHSH6080	SH-7085-ASP-15	SH-7085-ASP-15	SH-7085-ASP-15	SH-100130-ASP-15	SH-100130-ASP-15	SH-110130-ASP-15	SH-130150-ASP-15
27	SEAL RING	ALHSE060	ALHSE6070	ALHSE6070	ALHSE6070	ALHSE90100	ALHSE90100	ALHSE100110	ALHSE12013030
28	SHOE BOLT	SC1650HZN	SC2060HZN	SC2060HZN	SC2060HZN	SC2075HZN	SC2090HZN	SC20110HZN	SC24110HZN
29	SHOE BOLT WASHER	WAMW16ZN	WAMW20ZN	WAMW20ZN	WAMW20ZN	WAMW20ZN	WAMW20ZN	WAMW20ZN	WAMW24ZN
30	SHOE CENTERING PIN	ALHST0820	ALHST1025	ALHST1025	ALHST1025	ALHST1025			
31	BOLT ON PLATE SCREW				SC1660CST129	SC1660CST129	SC1660CST129		
32	NUT FOR REF 31				NU16NYSS	NU16NYSS	NU16NYSS		
33	COVER BOLT	SC1220CSS	SC1630CSS	SC1630CSS	SC1630CSS	SC1630CSS	SC1630CSS	SC1630CSS	SC2040CSS
34	COVER BOLT WASHER	WAM12ZSS	WAM16MSS	WAM16MSS	WAM16MSS	WAM16ZSS	WAM16ZSS	WAM16ZSS	WAM20ZSS
35	COVER STUD	23500110	23500210	23500210	23500210	23500210	23500210	23500210	23500310
36	NUT FOR REF 35	NU12NYSS	NU16NYSS	NU16NYSS	NU16NYSS	NU16NYSS	NU16NYSS	NU16NYSS	ALHN20NY
37	SIGHT GLASS BOLT	SC0620CSS	SC0620CSS	SC0620CSS	SC0620CSS	SC0620CSS	SC0620CSS	SC0620CSS	SC0620CSS
38	WASHER FOR REF 37	WAM06ZSS	WAM06ZSS	WAM06ZSS	WAM06ZSS	WAM06ZSS	WAM06ZSS	WAM06ZSS	WAM06ZSS
39	FRAME BOLT	SC1225HSS	SC1630HSS	SC1630HSS	SC1630HSS	SC2030HSS	SC2030HSS	SC2440HSS	SC2440HSS
40	WASHER FOR REF 39	WAM12ZSS	WAM16ZSS	WAM16ZSS	WAM16ZSS	WAM20ZSS	WAM20ZSS	WAM24ZSS	WAM24MSS
41	GEARBOX STUD	GUD939M1235-304	GUD939M1240	GUD939M1240	SC1212STHCST	GUD939M1650	GUD939M1650	GUD939M1650	GUD939M1650
42	NUT FOR REF 41	NU12NYSS	NU12NYZN	NU12NYZN	NU12NYZN	NU16NYSS	NU16NYZN	NU16NYZN	NU16NYZN
43	SEAL FLANGE BOLT				SC1016CSS	SC1016CSS	SC1016CSS	SC1016CSS	SC1016CSS
46	SIGHT GLASS SEAL	ALHX404600	ALH654600	ALH654600	ALH654600	ALH804600	ALH804600	ALH1004600	ALH1004600
47	INLET & OULET FLANGE DIN	ALH404700	ALH504700	ALH654700	ALH654700	ALH804700	ALH804700	ALH1004700	ALH1254701
47	INLET & OULET FLANGE ANSI	ALH404720	ALH504720	ALH654720	ALH654720	ALH804720	ALH804720	ALH1004720	ALH1254720
48	BRACKET BOLT	SC1016CSS	SC1220CSS	SC1220CSS	SC1220CSS	SC1220CSS	SC1620CSS	SC1625CSS	SC2030CSS
49	BRACKET BOLT WASHER								
51	90° BEND	ALHBEMF34SS	ALHBEMF1SS	ALHBEMF1SS	ALHBEMF1SS	ALHBEMF112SS	ALHBEMF112SS	ALHBEMF112SS	ALHBEMF112SS
52	BREATHER PLUG	ALHPV34	ALHPV1	ALHPV1	ALHPV1	ALHPV112	ALHPV112	ALHPV112	ALHPV112
59	WHEEL BOLT WASHER							ALH1005900	ALH1255900
60	WHEEL BOLT							SC2470HSS	SC2450HSS
63	LIFT RING ON COVER					ALHX806301-00-00	ALHEYCO1	ALHEYCO1	ALHEYCO1
64	BOLT FOR REF 63					SC1620CSS	SC1620CSS	SC1620CSS	SC1620CSS
67	O RING FOR SEAL FLANGE				ALHCO03450	ALHCO03450	ALHCO03450	ALHCO03450	ALHCO03745
70	GEARBOX CENTRING FLANGE				ALHX657001-00-300		ALH807000		
71	COVER FLANGE								
72	WASHER for REF 41	WAM12ZSS	WAM12ZSS	WAM12ZSS	WAM12ZSS	WAM16ZSS	WAM16ZSS	WAM16ZSS	WAM16ZSS
73	SPACER RING		ALH050R060.06	ALH050R060.06	ALH050R060.06	ALHX80SR090.13	ALHX80SR090.13	ALH100SR100.33	ALH125SR120.07
74	PLUG	ALHPL134GSS	ALHPL1GSS	ALHPL1GSS	ALHPL1GSS	ALHPL112GSS	ALHPL112GSS	ALHPL112GSS	ALHPL112GSS
75	O-RING FOR 73							ALHCO03370	
76	SPACER RING (ALH125 ONLY)								ALH125SR120.18
77	WASHER FOR 59							ASK ALBIN	ASK ALBIN
78	WASHER FOR LIFT RING 63						ASK ALBIN	ASK ALBIN	ASK ALBIN
79	NUT								ASK ALBIN
80	WASHER								ASK ALBIN
81	GUDGEON								ASK ALBIN
82	SILENT BLOC								ASK ALBIN
83	WASHER								ASK ALBIN
84	NUT								ASK ALBIN



ALH

Characteristics / Technical Specifications

9.5 - ALH BEARING CASE PARTS LIST (see specific exploded view)

REF.	DESIGNATION	ALH 05 ALH10	ALH15 ALH20	ALH25 TO ALH40	ALHX40 TO ALH65	ALHX65	ALHX80	ALH80	ALH100	ALH125
101	BEARING CASE (ALHS)	X	X	X	X	N/A	X	X	X	X
102	SHAFT (ALHS)	X	X	X	X	N/A	X	X	X	X
103	ROLLER BEARING (ALHS)	X	X	X	X	N/A	X	X	X	X
104	BALL BEARING (ALHS)	X	X	X	X	N/A	X	X	X	X
105	LIP SEAL (ALHS)	X	X	X	X	N/A	X	X	X	X
106	LIP SEAL (ALHS)	X	X	X	X	N/A	X	X	X	X
107	CIRCLIPS (ALHS)	X	X	X	X	N/A	X	X	X	X
108	GREASEER (ALHS)	X	X	X	X	N/A	X	X	X	X
109	SHAFT KEY (ALHS)	X	X	X	X	N/A	X	X	X	X
110	SHAFT KEY (ALHS)					N/A	X	X	X	X
111	PLUG (ALHS)	X	X	X	X	N/A	X	X	X	X

9.6 - HOSE RUPTURE AND VACUUM SYSTEM PARTS LIST (see specific exploded view)

REF.	DESIGNATION	CAPACITIVE HOSE RUPTURE DETECTOR	PRESSURE GAUGE HOSE RUPTURE DETECTOR	AUTOMATIC AIR VACUUM SYSTEM	AIR OPERATED VACUUM SYSTEM
51	90° BEND	X	X	X	X
52	VENT	X		X	X
200	HEXAGON NIPPLE	X		X	X
201	TEE CONNECTION	X		X	
202	HEXAGON NIPPLE	X		X	
203	ADAPTOR	X	X	X	X
204	AIR SUPPLY CHECK VALVE			X	
205	AIR SUPPLY CONNECTION			X	
206	AIR SUPPLY HOSE			X	
207	VACUUM FLANGE			X	



ALH

Characteristics / Technical Specifications

9.7 - LUBRICATION TABLE

The table indicates the quantity of lubricant necessary for every pump size. Employ only the ALBIN lubricant for ALBIN hose pumps. refer to §6.2 for lubricant emptying and filling.

LUBRICANT

L (gal)

PUMPS	ALH 5-10	ALH15-20	ALH25	ALH32	ALH40	ALHX40	ALH50	ALHX65	ALH65	ALHX80	ALH80	ALH100	ALH125
QUANTITY OF LUBRICANT	0.2 (0.05)	0.55 (0.14)	2 (0.53)	3 (0.8)	3 (0.8)	6 (1.59)	13 (3.43)	14 (3.7)	13 (3.43)	27 (7.13)	40 (10.57)	80 (21.13)	120 (31.7)

9.8 - SHOE SHIMMING TABLE

Refer to §6.5 to remove or add shims. The table below points out the necessary number of shims under every shoe according to the speed, pressure and the temperature of the product. Respect these indications scrupulously to optimize the hose life and to avoid a possible deterioration of the internal parts. For temperatures exceeds 60°C (140°F), withdraw one shim in comparison with the table below. For viscosities over 3000cP or concentrations exceeding 300g / l, withdraw one shim in comparison with the table below. For a suction lift higher than 4 meters, add one shim to the following figures.

CAUTION: Every shoe must include the same number of shims 0.5mm (0.02 inch).

PUMP TYPE ALH25		
Pressure bar (psi)	Speed - Rpm	Number of shims
$\Delta P \leq 5$ (72.5)	0 to 40	0
	40 to 160	0
5 (72.5) $\leq \Delta P \leq 7.5$ (108.75)	0 to 40	2
	40 to 125	1
7.5 (108.75) $\leq \Delta P \leq 10$ (145)	0 to 40	3
	40 to 105	2
10 (145) $\leq \Delta P \leq 15$ (217.5)	0 to 40	4
	40 to 90	3

PUMP TYPE ALH32		
Pressure bar (psi)	Speed - Rpm	Number of shims
$\Delta P \leq 5$ (72.5)	0 to 45	0
	45 to 140	0
5 (72.5) $\leq \Delta P \leq 7.5$ (108.75)	0 to 45	2
	45 to 140	1
7.5 (108.75) $\leq \Delta P \leq 10$ (145)	0 to 45	3
	45 to 110	2
10 (145) $\leq \Delta P \leq 15$ (217.5)	0 to 45	4
	45 to 80	3

PUMP TYPE ALH40		
Pressure bar (psi)	Speed - Rpm	Number of shims
$\Delta P \leq 5$ (72.5)	0 to 40	0
	40 to 160	0
5 (72.5) $\leq \Delta P \leq 7.5$ (108.75)	0 to 40	2
	40 to 125	1
7.5 (108.75) $\leq \Delta P \leq 10$ (145)	0 to 40	3
	40 to 105	2
10 (145) $\leq \Delta P \leq 15$ (217.5)	0 to 40	4
	40 to 90	3

PUMP TYPE ALHX40		
Pressure bar (psi)	Speed - Rpm	Number of shims
$\Delta P \leq 5$ (72.5)	0 to 40	0
	40 to 120	0
5 (72.5) $\leq \Delta P \leq 7.5$ (108.75)	0 to 40	2
	40 to 95	1
7.5 (108.75) $\leq \Delta P \leq 10$ (145)	0 to 40	3
	40 to 75	2
10 (145) $\leq \Delta P \leq 15$ (217.5)	0 to 40	4
	40 to 60	3



ALH

Characteristics / Technical Specifications

PUMP TYPE ALH50		
Pressure bar (psi)	Speed - Rpm	Number of shims
$\Delta P \leq 5$ (72.5)	0 to 30	0
	30 to 100	0
5 (72.5) $\leq \Delta P \leq 7.5$ (108.75)	0 to 30	2
	30 to 65	1
7.5 (108.75) $\leq \Delta P \leq 10$ (145)	0 to 30	3
	30 to 50	2
10 (145) $\leq \Delta P \leq 15$ (217.5)	0 to 30	4
	30 to 42	3

PUMP TYPE ALH65		
Pressure bar (psi)	Speed - Rpm	Number of shims
$\Delta P \leq 5$ (72.5)	0 to 30	0
	30 to 90	0
5 (72.5) $\leq \Delta P \leq 7.5$ (108.75)	0 to 30	2
	30 to 55	1
7.5 (108.75) $\leq \Delta P \leq 10$ (145)	0 to 30	3
	30 to 47.5	2
10 (145) $\leq \Delta P \leq 15$ (217.5)	0 to 30	4
	30 to 40	3

PUMP TYPE ALHX65 AND ALHX80		
Pressure bar (psi)	Speed - Rpm	Number of shims
$\Delta P \leq 5$ (72.5)	0 to 25	0
	25 to 65	0
5 (72.5) $\leq \Delta P \leq 7.5$ (108.75)	0 to 25	2
	25 to 46	1
7.5 (108.75) $\leq \Delta P \leq 10$ (145)	0 to 25	3
	25 to 40	2
10 (145) $\leq \Delta P \leq 15$ (217.5)	0 to 25	4
	25 to 31	3

PUMP TYPE ALH80		
Pressure bar (psi)	Speed - Rpm	Number of shims
$\Delta P \leq 5$ (72.5)	0 to 20	0
	20 to 60	0
5 (72.5) $\leq \Delta P \leq 7.5$ (108.75)	0 to 20	2
	20 to 47	1
7.5 (108.75) $\leq \Delta P \leq 10$ (145)	0 to 20	3
	20 to 37	2
10 (145) $\leq \Delta P \leq 15$ (217.5)	0 to 20	4
	20 to 31	3

PUMP TYPE ALH100		
Pressure bar (psi)	Speed - Rpm	Number of shims
$\Delta P \leq 5$ (72.5)	0 to 15	0
	15 to 50	0
5 (72.5) $\leq \Delta P \leq 7.5$ (108.75)	0 to 15	2
	15 to 32.5	1
7.5 (108.75) $\leq \Delta P \leq 10$ (145)	0 to 15	3
	15 to 25	2
10 (145) $\leq \Delta P \leq 15$ (217.5)	0 to 15	4
	15 to 20	3

PUMP TYPE ALH125		
Pressure bar (psi)	Speed - Rpm	Number of shims
$\Delta P \leq 5$ (72.5)	0 to 10	0
	10 to 35	0
5 (72.5) $\leq \Delta P \leq 7.5$ (108.75)	0 to 10	2
	10 to 27.5	1
7.5 (108.75) $\leq \Delta P \leq 10$ (145)	0 to 10	3
	10 to 25	2
10 (145) $\leq \Delta P \leq 15$ (217.5)	0 to 10	4
	10 to 20	3

9.9 - GENERATED NOISE AND TEMPERATURE

NOISE :

The ALBIN PUMPS do not generate more than 60dB during their operation.

TEMPERATURE :

The cover and the pump casing can become very hot due to the friction on the hose and liquid temperature. If you need to limit the pump temperature, please contact your ALBIN PUMP distributor.



ALH

Characteristics / Technical Specifications

9.10 - EXPANSIBLE HUB ASSEMBLY AND DISASSEMBLY: GENERALITIES

ASSEMBLY:

Slightly grease contact surfaces, threads, shaft and wheel bore and introduce the hub inside the wheel. Pre-tighten the screws and place this unit on the gearbox shaft and position according to the table §6.4.2 Cross-tighten the screws two or three times and tighten to the according torque §9.11 TORQUE AND FIGURES.

DISASSEMBLY:

Untighten the screws on the hub and place them in the unlock holes. Tighten the screws until the two elements of the hub disassemble and withdraw the wheel hub.

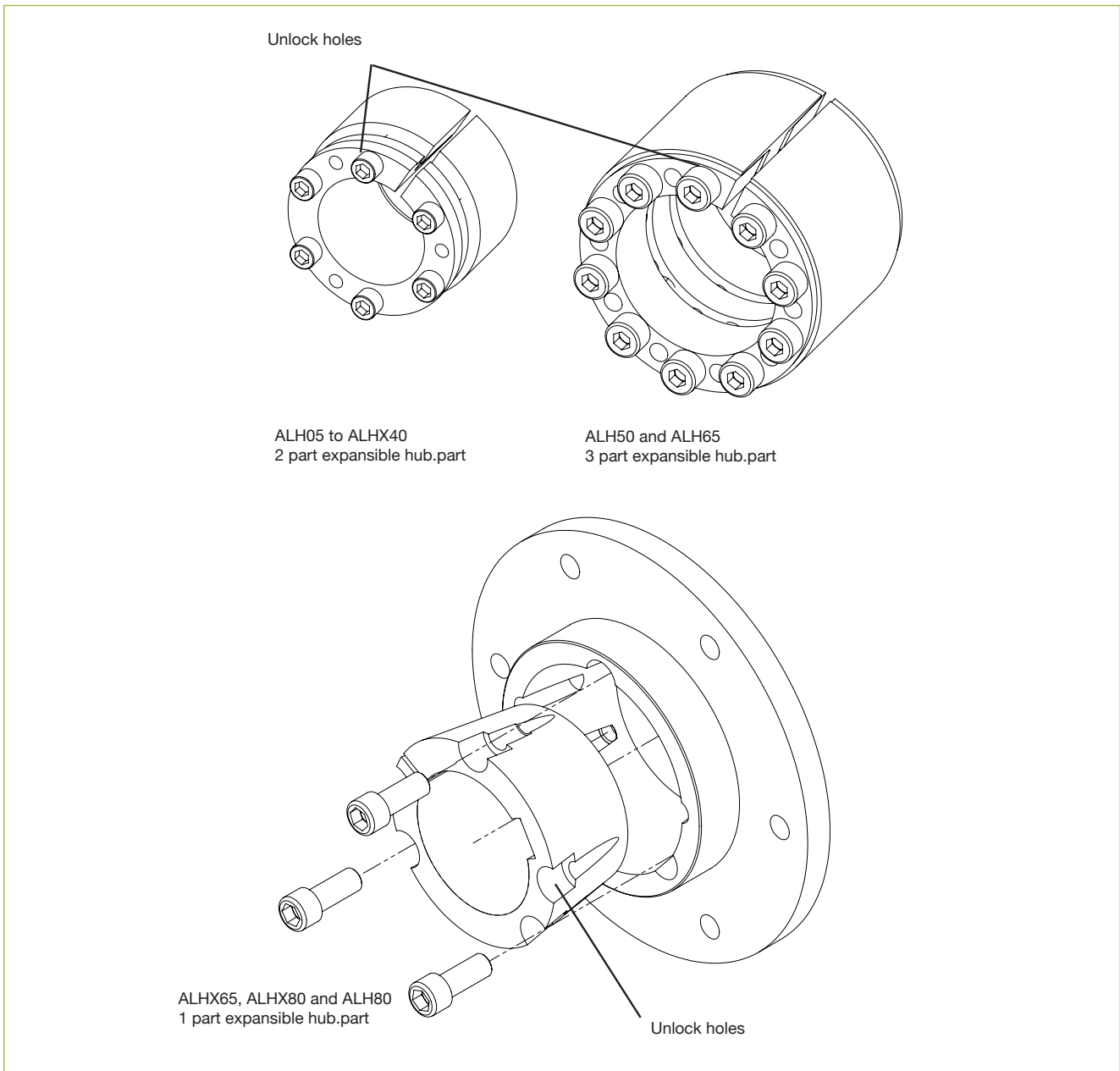



ALH

Characteristics / Technical Specifications

9.11 - TORQUE FIGURES

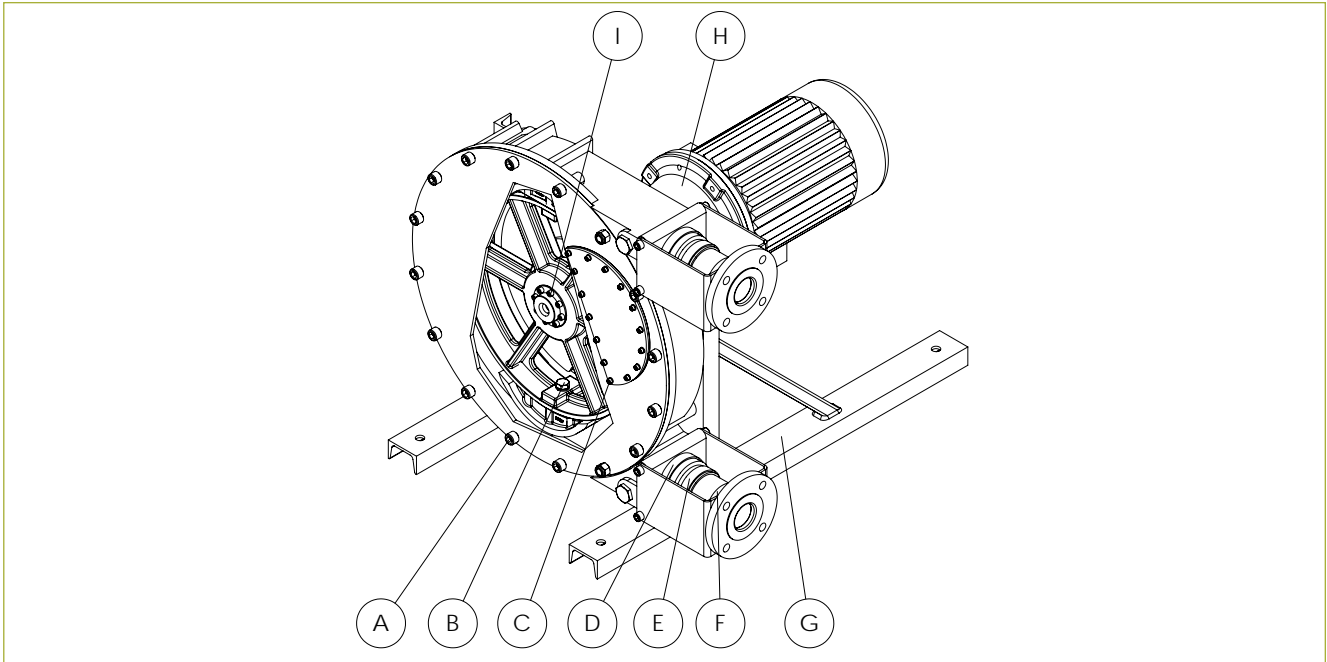

TORQUE Nm (Ft-lbs)

ITEM	DESCRIPTION	MAX TORQUE IN FT-LBS (NM) - CERTIFIED TOOLING REQUIRED									
		ALH05 ALH20	ALH25	ALH32 ALH40	ALHX40	ALH50 ALH65	ALHX65	ALHX80	ALH80	ALH100	ALH125
A	COVER	3.3 (2.4)	7.8 (5.7)	27 (19.9)	27 (19.9)	65 (47.9)	65 (47.9)	65 (47.9)	65 (47.9)	127 (93.7)	127 (93.7)
B	SHOE		46 (33.9)	79 (58.3)	79 (58.3)	402 (296.5)	402 (296.5)	402 (296.5)	402 (296.5)	691 (509.6)	691 (509.6)
C	WINDOW		3.3 (2.4)	3.3 (2.4)	3.3 (2.4)	3.3 (2.4)	3.3 (2.4)	3.3 (2.4)	3.3 (2.4)	3.3 (2.4)	3.3 (2.4)
D	CLAMP REF 7	4 (2.9)	4 (2.9)	4 (2.9)	4 (2.9)	4 (2.9)	4 (2.9)	4 (2.9)	4 (2.9)	4 (2.9)	4 (2.9)
E	CLAMP REF 8	12 (8.8)	16 (11.8)	30 (22.1)	30 (22.1)	30 (22.1)	30 (22.1)	30 (22.1)	45 (33.2)	45 (33.2)	45 (33.2)
F	CLAMP REF 9	12 (8.8)	50 (36.9)	50 (36.9)	50 (36.9)	50 (36.9)	50 (36.9)	50 (36.9)	50 (36.9)	50 (36.9)	50 (36.9)
G	FRAME	8 (5.9)	15 (11.0)	27 (19.9)	27 (19.9)	65 (47.9)	65 (47.9)	127 (93.7)	127 (93.7)	220 (162.2)	220 (162.2)
H	GEARBOX	34 (25.0)	67 (49.4)	116 (85.5)	116 (85.5)	116 (85.5)	116 (85.5)	291 (214.6)	291 (214.6)	291 (214.6)	291 (214.6)
I	HUB	12 (8.8)	13 (9.6)	13 (9.6)	27 (19.9)	35 (25.8)	90 (66.3)	110 (81.1)	110 (81.1)		



ALH

Characteristics / Technical Specifications

9.12 - WEIGHT ALH AND ALHS SERIES

WEIGHT kg (lbs)

WEIGHT								
PART	ALH05-10	ALH15	ALH20	ALH25	ALH32	ALH40	ALHX40	ALH50
CASING	5 (11)	8 (17.6)	8 (17.6)	16 (35.3)	29 (63.9)	29 (63.9)	43 (94.8)	88 (194)
WHEEL	1.2 (2.6)	3 (6.6)	3 (6.6)	4.3 (9.5)	7.7 (17)	7.7 (17)	12.9 (28.4)	27.5 (60.6)
COVER	0.3 (0.7)	0.6 (1.3)	0.6 (1.3)	5 (11)	22.7 (50)	10.3 (22.7)	15.4 (33.9)	23.5 (51.8)
FRAME	1.3 (2.9) (X2)	1.7 (3.7) (X2)	1.7 (3.7) (X2)	6 (13.2) (X2)	12.5 (27.6) (X2)	12.5 (27.6) (X2)	13.4 (29.5) (X2)	15.9 (35.1) (X2)
SHOE				0.56 (1.2)	0.86 (1.9)	1.26 (2.8)	1.5 (3.3)	3.43 (7.6)
HOSE	0.4 (0.9)	0.8 (1.8)	1.4 (3.1)	2 (4.4)	3 (6.6)	3 (6.6)	4 (8.8)	6 (13.2)

WEIGHT						
PART	ALH65	ALHX65	ALHX80	ALH80	ALH100	ALH125
CASING	88 (194)	111 (245)	140 (308.6)	240 (529.1)	375 (826.9)	450 (992.0)
WHEEL	27.5 (60.6)	26Kg (57 lb)	37.3 (82.2)	62.3 (137.4)	89 (196.2)	173 (381.5)
COVER	23.5 (51.8)	28Kg (62 lb)	41 (90.4)	60 (132.3)	89 (196.2)	203 (447.5)
FRAME	15.9 (35.1) (X2)	15.9 (35.1) (X2)	25.5 (56.2) (X2)	48 (105.8) (X2)	62.5 (137.8) (X2)	274 (604.2)
SHOE	4.15 (9.1)	8Kg (18 lb)	10.4 (22.9)	10.4 (22.9)	9.26 (20.4)	30.4 (67.0)
HOSE	6 (13.2)	9Kg (20 lb)	15 (33.1)	20 (44.1)	30 (66.1)	45 (99.2)



ALH

Supplemental Instructions for ATEX Certified Materials

10 | SUPPLEMENTAL INSTRUCTIONS FOR ATEX CERTIFIED MATERIALS

Peristaltic hose pump

Complementary instructions for ATEX certified material.

Models: Albin Pump ALH and ALHS

Pumping and operation in zone 0 is completely banned.

The pumps are planned for a use in the following gas and dust explosive atmospheres.

II 2G : zone 1 and 2

II 3G : zone 2 only

II 2D : zone 1 and 2

II 3D : zone 2 only

The following instructions must be read jointly with:

- > All ATEX regulations for the country for which the pump is destined.
- > Decrees, laws, directives, application circulars, the standards, the code of practice, and any other document concerning its place of installation.

No responsibility whatsoever is taken for the non-observance of these instructions.

The ATEX form provided by the customer which stipulates all the data concerning his process and application of the pump is the only evidence in case of dispute. The non-observance of this data will disengage the responsibility of ALBIN PUMP.

This information is complementary to our general maintenance manual.

The installation of the material must be carried out by qualified and skilled personnel.

Our equipment is marked EEC with the ATEX 94/9/CE title.

Ensure compatibility between the indications being reproduced on the gauge, the present explosive atmosphere, the zone of use, ambient and surface temperatures.

Until the 30.06.2003, the equipment on the market could be equipped with accessories or (and) components certified according to the rules of CENELEC relating to the electric materials usable in explosive atmospheres of group II. From this date, the accessories or (and) component assembled equipping the motors with our pumps must have an EEC examination certificate.



ALH

Supplemental Instructions for ATEX Certified Materials

SUMMARY

- 1 - Level of pumps certification
- 2 - Protection of the pumping part
- 3 - Protection of the transmission part
- 4 - Particular dispositions when using a frequency inverter
- 5 - Dry running the pumps
- 6 - Replacement of parts
- 7 - Solvents incompatible with pump seals
- 8 - Possible leakage of pumped liquid
- 9 - Checking lubricant level in the pump
- 10 - Drive of the pump
 - 10.1 Alignment of the pump and the drive (only for the ALHS pump)
 - 10.2 Flexible couplings
 - 10.3 Electric installation of the motor or the motor reducer of the pump
 - 10.4 ATEX characteristics of the motor or the motor reducer of the pump
- 11 - ATEX characteristics of the pumping installation
- 12 - Pumping vat of retention
- 13 - Marking of the pump



ALH

Supplemental Instructions for ATEX Certified Materials

1 - Pump certification levels

All ALBIN peristaltic pumps are certified with II 2G T4, II 3G T4 or II 2D T4 certification.

All ALBIN peristaltic pumps are certified with II 2G T4, II 3G T4 or II 2D T4 certification. The pumps are machines whose surface temperatures are very dependent on the temperature of the product that they pump. Moreover, the peristaltic pumps have “mechanical” heating due to the deformations of the hose, depending on the discharge pressure and speed of rotation of the pump. So, the level of protection II 2G T4, II 3G T4, II 3D T4 and II 3D T4 is obtained with the working limits determined at the reception of the ATEX form (see adjoined form).

Pumps ALH05, ALHS05, ALH10, ALHS10, ALH20 and ALHS20 are limited to a maximum discharge pressure of 7.5 bar (108.8 psi).

Pumps ALH25 to ALH125 and AHS25 to ALHS125 are limited to a maximum discharge pressure of 15 bar.

Going beyond the working limitations specified at the sale is regarded as an abnormal function of the pump. This can generate surface temperatures higher than the safe maximum surface temperatures recommended in the classification of temperature (T) for which the pump was certified. It is the responsibility of the operator to respect these working limits.

In order to use the pump industrially with the required safety levels, safety devices have been provided (see the chapters “Protection of the pumping part” and “Protection of the transmission part”).

2 - Protection of the pumping part

The heating of the pumping part is directly related to the functioning temperature (T) of the hose. The lifespan of the hose, which is the heart of any peristaltic pump, is strongly dependent on the working temperature (T) of the hose: it imposes the working limits of the ALBIN peristaltic pumps. Consequentially, the working temperature of the hose (and thus the heating of the pump) must be known and controlled, and it depends on the three following parameters:

- > Temperature of pumped product
- > Number of rotations of the pump
- > Discharge pressure



ALH

Supplemental Instructions for ATEX Certified Materials

For pumps II 2G T4

Use of a PT100 temperature sensor only in a gas atmosphere.

The permanent control of the maximum surface temperature of the pump housing makes it possible to control the heating of the pump effectively.

In the event of dysfunction of the pump (excessive rotation, too high temperature of pumped product, unsuitable shimming of the shoes...), the temperature sensor will detect any passing over the critical temperature of the body and will stop the pump before the surface temperatures of the pump exceed the limit corresponding to the classification of temperature (T) of the pump.

The threshold of release of the temperature sensor will have to be adjusted from 0°C (32°F) to 75°C (165°F) more or less 5°C (41°F), with a 10°C (50°F) hysteresis.

For the certified pumps II 3G T4, II 2D and II 3D :

For dust zones, D becomes IP6X

According to the specific requirements for ATEX materials group II category 3, the use of such materials in an exposable atmosphere is adapted only under normal working conditions of the known material.

Thus, the end-user must make sure that the pump is used under normal working conditions, and that the particular working limits indicated in this manual are respected.

3 - Protection of the transmission part

The reducer and the motor which motorize the pump must be used within the limits of working defined by the manufacturers of these materials. Going beyond these limits is likely to generate a risk of ignition of the atmosphere surrounding the material.

The ALBIN PUMP installations are in particular designed so that the normal working conditions of the pump do not generate an overload of the motor or the reducer.

So that the function limits of these components are not exceeded, even in case of dysfunction of the pump, the motor will have to be protected from the overcurrent, in accordance with the code of practice.



ALH

Supplemental Instructions for ATEX Certified Materials

4 - Particular dispositions when using a frequency inverter

The ALBIN peristaltic pumps have variable limits of working according to the discharge pressure, number of rotations of the pump and temperature of the pumped product. These working limits are mainly imposed by the heating of the hose, on which the lifespan is strongly dependent.

Within the framework of an application required to change the speed of the pump, the three following points will have to be checked:

- > Temperature of pumped product
- > Number of rotations of the pump
- > Discharge pressure

The maximum values of use will be fixed at the determination of the pump whose copy is in the appendix.

5 - Dry running the pumps

The ALBIN peristaltic pumps can function in the absence of liquid in the pump, without causing heating of the pump higher than the classified of temperature T, in particular for the period of starting-up of the pump.

In fact, dry running the pump with blocked inlets or outlets generates too high a demand on the pump hose, and can generate high internal temperatures because of the compression and decompression of the air locked up between the pump and the blocked opening.

This type of dysfunction is not controllable by a safety device (of sensor type) because the pump is dry and the mechanical constraints generated on the pump are low. Starting up the pump must thus be done after having checked that the inlet and outlet are not blocked.

Nevertheless, dry running is not a normal function of the pump and if it doesn't directly constitute a risk of ignition, it leads to premature wear and tear of the hose. This type of function must be limited as much as possible.

6 - Replacement of parts

The parts should be replaced only by original ALBIN parts which correspond to the configuration of origin of the pump. If necessary, the characteristics of the pump are modified and the ATEX certification of the pump is not applicable any more.

With each hose replacement, the adjustment of compression of the hose must be controlled and adapted to the instructions of adjustment registered in the handbook. The technicians who intervene on ATEX material must be ATEX trained and approved.



ALH

Supplemental Instructions for ATEX Certified Materials

7 - Solvents incompatible with the pump's seals

The user must make sure that the seals and the hose with which the pump is equipped are compatible with the pumped product and the products used in the cleaning of the pump.

8 - Possible leakages of pumped liquid

The possible leakages of liquid by the pump's seals do not generate a risk of ignition as long as the explosive atmosphere surrounding the material corresponds to the type of atmosphere for which it was planned.

Please verify the atmosphere in contact with the pump, materials located near the pump, and liquids being pumped are not likely to create an explosive effect for which the material was not envisaged.

The rupture of the hose, which is a wearing part, can involve important leakage of pumped liquid. A hose detector makes it possible to detect these leakages and will stop the pump if necessary.

9 - Checking of the lubricant level in the pump

An insufficient lubricant level in the pump can generate surface temperatures higher than the recommended limit of temperature (T) of the pump. Stop the pump and check the lubricant level every 1000 working hours.



ALH

Supplemental Instructions for ATEX Certified Materials

10 - Drive the pump

The maximum speed of rotation of the pumps must be respected (see certification of the pumps).

At the start or after any modification of the pumping installation, the speed of rotation of the pump must be controlled and must be lower than the maximum speed indicated in the instructions.

10.1 - Alignment of the pump and the drive (only for the ALHS pumps)

To carry out the alignment and the coupling, use a perfectly straight ruler to control offsetting and thickness gauges for angular misalignment.

It is important to control alignment with each stage of the installation as indicated below in order to make sure that none of these stages generate constraints on the group or the pump :

- after fixing the pump on the foundations
- after fixing the piping
- after the pump has functioned at a normal temperature of use

IMPORTANT: one should not rely on the flexible coupling to compensate for a misalignment.

10.2 - Flexible coupling

Certified ATEX flexible coupling must be used. These couplings must have a level of protection equivalent or higher than that of the pumping installation.

For the instructions of maintenance of certified ATEX flexible coupling of the ALBIN pumping installations, please refer to the technical note of the coupling.

10.3 - Electric installation of the motor or the motor reducer of the pump

Check the agreement between the indications of the motor gauge and the supply voltage.

For the connection of the motor to the electrical supply network, follow the indications of the manual supplied with the motor. Follow the assembly diagram of wiring, make sure the wires are adapted to the power consumption and make sure the contacts are tight.

The motors must be protected by suitable circuit breakers and fuses.

Make sure the earth connections are properly made.

Dry run the pump to make sure that the connections are correct and that the direction of rotation corresponds well with the suction and the discharge of the installation.



ALH

Supplemental Instructions for ATEX Certified Materials

10.4 - Ground connection of pump

A bonding strip lug can be seen on the frames of ALH type pumps and on the pump housing and bearing case of the ALHS type pumps.

10.5 - ATEX characteristics of the motor or the motor reducer of the pump

The motor or motor reducer must have ATEX characteristics adapted to recognized use (group gas IIB, class of temperature T4) and must be explosion-proof.

11 - ATEX characteristics of the pumping installation

A pumping installation can be composed of materials (motor, reducer, sensors...) from which ATEX characteristics are different from those of the pump.

In this case, the group will have ATEX characteristics corresponding to ATEX characteristics of the component with the lowest level of protection.

12 - Pumping vat of retention

At a constant arrival of liquid in a vat of retention in an ATEX zone, the uninterrupted start-up can generate a classification in zone 0.

The case can only arise when the pump is used in the starting position. It is then imperative that the suction pipe always has liquid present so as not to create explosive conditions in the presence of fuel and combusive agents. Thus, the adjustment of the low point of the tank will have to be higher than the opening of the suction pipe.

That will always result in the presence of liquid and not of gas and liquid.

13 - Marking of the pump

The marking of the ALBIN PUMPS is of type:

ALBIN:

TYPE ALH or ALHS
II 2 G T4 or II 3 G T4

N° series:

Year:

The marking of the ALBIN GROUPS is of type:

ALBIN:

Group ALH or ALHS
II 2 G T4 or II 3 G T4

N° series:

Year:

In the case of a pumping group, ATEX certified materials will retain their original markings.



ALH

Security Form

11 | SECURITY FORM

In compliance with Health & Safety Regulations you, the user are required to declare the substances that have been in contact with the product(s) you are returning to ALBIN PUMP or any of its subsidiaries or distributors. Failure to do so will cause delays in servicing the item or in issuing a response. Therefore, please complete this form to ensure that we have the information before receipt of the item(s) being returned.

A FURTHER COPY MUST BE ATTACHED TO THE OUTSIDE OF THE PACKAGING CONTAINING THE ITEM(S).

You, the user, are responsible for cleaning and decontaminating the item(s) before returning them. Please complete a separate decontamination certificate for each item returned.

1.0 COMPANY

Company name
Address
City
Postal code
Country
Telephone
Fax number

2.0 PUMP

2.1 Serial number

2.2 Has the pump been used ? YES NO

If yes, please complete all the following paragraphs. If no, please complete paragraph 5 only

3.0 Details of substances pumped

3.1 Chemical Names

a) _____ b) _____ c) _____

3.2 Precautions to be taken in handling these substances

a) _____ b) _____ c) _____

3.3 Action to be taken in the event of human contact

a) _____ b) _____ c) _____

3.4 Cleaning fluid to be used if residue of chemical is found during servicing

4.0 I hereby confirm that the only substances(s) that the equipment specified has pumped or come into contact with are those named, that the information given is correct, and the carrier has been informed if the consignment is of a hazardous nature.

5.0 Signatory authorized

Signed _____

Name _____

Position _____

Date _____

Remarks: to assist us in our servicing please describe any fault condition you have witnessed.



ALH

Statement of CE Compliance

12 | STATEMENT OF CE COMPLIANCE

SECTION 1.0

Description of the pump:

Producer:

ALBIN PUMP

Z.I. du Meyrol

6, Avenue du Meyrol

F-26200 MONTELMAR

FRANCE

TEL : +33.4.75.90.92.92

Type:

ALH05 - ALH10 - ALH15 - ALH20 - ALH25 - ALH32 - ALH40 - ALHX40 - ALH50 - ALH65 -
ALHX80 - ALH80 - ALH100 - ALH125

Serial N°:

Description : Volumetric pump, hose pump

SECTION 2.0

Applicable directives:

Machinery directives:

2006/42/EC

SECTION 3.0

Label:



SECTION 4.0

Statement:

We declare under our responsibility that the equipment defined in section 1.0 satisfies in all the directives of the European Community specified in section 2.0 and in the French work legislation.

Thomas Mapelli

Date: XX XX XXXX



ALH

Safety and Control Measures to Respect Imperatively

SAFETY AND CONTROL MEASURES TO RESPECT IMPERATIVELY

1 - Mechanical risk

Ensure that all protections (cover, sight glass, ventilator hood, coupling protection) are in place before operating the pump. Disconnect the electricity supply before any mechanical intervention, except during a hose replacement. Hose replacement must be done with the pump cover closed. While replacing a hose, wear protective gloves and clothes and keep hands away from the brackets, suction and discharge flanges.

During the pump maintenance, check that the lifting points are correctly used.
The frame of the pump must be firmly fastened to the ground.

2 - Electrical risk

Ensure that the electrical installation is conforming to the standards required in the country of use especially regarding earth and thermal protection.

3 - Operational risk

Check the compatibility of the products to be pumped with:

- The peristaltic pump principle.
- The hose material.
- The inserts material.
- The shoe material.

ALBIN PUMP cannot guaranty the hose lifetime or the product loss due to a hose burst. It is the operator's responsibility to prevent pumped liquid loss with additional hose rupture detectors and or automatic shutdown valves. Check §2.4 conditions of guarantee for further information.

Ensure that the pump is compatible with the required process. Ensure that the pressure applied on the suction side is compatible with the pump. The rupture of the hose and its consequences must be taken in account:

- The pump casing can be filled with the pumped product.
- If the suction line is on load, this one can empty into the pump casing and leak out of the pump.
- If the discharge line is under pressure, the pumped product may be forced back into the pump casing and leak out of the pump.

A leakage detector as well as automatic shutdown valves are recommended in order to prevent such consequences. While draining the pump following a hose rupture, take note of the risk of pollution caused by the pumped product.

The pump, being volumetric, may suffer dangerously high pressure by even partial blockage of the discharge line. Ensure that all protections have been made regarding this aspect.

Before each use, check the direction of rotation of the pump. While placing the pump under vacuum, mount window screws using an airtight glue to avoid air leakage.

AUSTRALIAN DISTRIBUTOR



CALL 1300 789 466

When Pump Knowledge Matters

www.kelairpumps.com.au

Distributed by:

www.albinpump.com

albinpump@irco.com



About Ingersoll Rand Inc.

Albin Pump is a brand of Ingersoll Rand and part of the Precision and Science Technologies (PST) business segment. PST consists of a portfolio of complementary, mission critical brands such as Milton Roy®, ARO®, LMI®, Albin Pump, Thomas®, Welch®, Haskel®, Dosatron®, YZ®, Williams®, MP® and Oberdorfer®.

At PST, we deliver solutions for precision dosing and transfer of high value fluids in various markets such as medical, food and beverage, water and hydrogen. For more information, visit www.IRco.com.

We are committed to using environmentally conscious print practices

©2021 Ingersoll Rand
PN 97999-1953
REV: D