



Lowara
ITT



KelairPumps

CALL 1300 789 466

When Pump Knowledge Matters

www.kelairpumps.com.au

it	ELETTROPOMPE SOMMERGIBILI SERIE GLS - GLV	Istruzioni d'installazione, uso e manutenzione
en	SUBMERSIBLE PUMPS GLS - GLV SERIES	Installation, Operating and Maintenance Instructions
fr	ELECTROPOMPES SUBMERSIBLES SÉRIE GLS - GLV	Instructions pour l'installation, l'utilisation et l'entretien
de	TAUCHMOTORPUMPEN BAUREIHEN GLS - GLV	Installations,- Bedienungs - und Wartungsanleitungen
es	ELECTROBOMBAS SUMERGIBLES SERIES GLS - GLV	Instrucciones para la instalación, el uso y el mantenimiento
pt	ELECTROBOMBAS SUBMÉRGIWEIS SÉRIES GLS - GLV	Instruções de instalação, uso e manutenção
nl	ONDERWATERPOMPEN SERIE GLS - GLV	Aanwijzingen voor de installatie, het gebruik en het onderhoud
sv	DRÄNKBARA ELPUMPAR SERIE GLS - GLV	Installations-, bruks- och underhållsanvisning
fi	UPOTETTAVAT SÄHKÖPUMPUT GLS - GLV -SARJA	Asennus-, käyttö- ja huolto-ohjeet
ru	ПОГРУЖНЫЕ ЭЛЕКТРОНАСОСЫ СЕРИЯ GLS - GLV	Инструкции по монтажу, эксплуатации и техобслуживанию
el	ΥΠΟΒΡΥΧΙΕΣ ΗΛΕΚΤΡΙΚΕΣ ΑΝΤΛΙΕΣ ΣΕΙΡΑ GLS - GLV	Οδηγίες εγκατάστασης και χρήσης και συντήρηση
da	DYKELEKTROPUMPER SERIE GLS - GLV	Manual vedrørende installation, brug og vedligeholdelse
no	NEDSENKBARE ELEKTROPUMPER SERIE GLS - GLV	Håndbok for installasjon, bruk og vedlikehold
pl	ELEKTROPOMPY ZANURZENIOWE SERII GLS - GLV	Instrukcje montażu, obsługi i konserwacji
cs	PONORNÁ ELEKTROČERPADLA SÉRIE GLS - GLV	Návod na montáž, používání a údržbu
sk	PONORNÉ ČERPADLÁ SÉRIE GLS - GLV	Návod na montáž, používanie a údržbu
hu	ELEKTROMOS MERÜLŐSZIVATTYÚK GLS - GLV SZOROZAT	Telepítési, használati és karbantartási utasítás
sl	POTOPNE ELEKTRIČNE ČRPALKE SERIJE GLS - GLV	Navodila za montažo, uporabo in vzdrževanje
ro	ELECTROPOMPE SUBMERSIBILE SERIA GLS - GLV	Instrucțiuni de instalare, utilizare și întreținere
bg	ПОТОПЯЕМИ ЕЛЕКТРИЧЕСКИ ПОМПИ МОДЕЛИ GLS - GLV	Ръководство за инсталиране, употреба и поддръжка
tr	GLS - GLV SERİSİ ELEKTRİKLİ DALGIÇ POMPALAR	Kurulum, kullanım ve bakım talimatları
uk	ЗАГУРЮВАЛЬНІ ЕЛЕКТРОНАСОСИ СЕРІЯ GLS-GLV	Інструкції з монтажу, експлуатації та обслуговування
ar	المضخات الكهربائية الغاطسة موديل GLS - GLV	تعليمات التركيب والاستخدام



it	Conservate con cura il manuale per future consultazioni
en	Keep this manual for future reference
fr	Conservez avec soin le manuel pour toute consultation future
de	Das Handbuch muss für zukünftige Konsultationen sorgfältig aufbewahrt werden
es	Guardar con cuidado el manual para poderlo consultar en el futuro
pt	Conservar cuidadosamente o manual para consultas futuras
nl	Bewaar de handleiding zorgvuldig voor latere raadpleging
sv	Spara bruksanvisningen för framtida bruk
fi	Säilytä käyttöopas huolellisesti
ru	Бережно хранить руководство для будущих консультаций
el	Διατηρείτε επιμελώς το εγχειρίδιο για μελλοντικές χρήσεις
da	Gem manualen til senere brug
no	Ta vare på håndboken for senere bruk
pl	Zachować z ostrożnością do przyszłych konsultacji
cs	Pečlivě tento návod uschovejte pro budoucí použití
sk	Tento návod starostlivo uschovejte pre budúce použitie
hu	Gondosan őrizze meg a kézikönyvet jövőbeni szűkség esetére
sl	Priročnik skrbno hranite za bodoča branja
ro	Păstrați cu grijă manualul pentru consultări ulterioare.
bg	Съхранявайте ръководството за справка
tr	Lütfen bu el kitabını ileride başvurmak üzere güvenli bir biçimde saklayınız
uk	Збережіть цю інструкцію для подальшого використання
ar	احتفظوا بكتيب التعليمات للرجوع إليه مستقبلياً

it AVVERTIMENTI PER LA SICUREZZA DELLE PERSONE E DELLE COSE

Di seguito trovate il significato dei simboli utilizzati nel presente manuale



PERICOLO

Rischio di danni alle persone, e alle cose, se non osservate quanto prescritto



SCOSSE ELETTRICHE

Rischio di scosse elettriche se non osservate quanto prescritto



AVVERTENZA

Rischio di danni alle cose (pompa, impianto, quadro,...) o all'ambiente se non osservate quanto prescritto



Leggete attentamente il manuale prima di procedere

Informazioni per :

il trasportatore

Informazioni specifiche per chi trasporta, movimenta, immagazzina il prodotto

l'installatore

Informazioni specifiche per chi procede all'installazione del prodotto nell'impianto (per la parte idraulica e/o elettrica)

l'utilizzatore

Informazioni specifiche per chi usa il prodotto

il manutentore

Informazioni specifiche per chi cura la manutenzione del prodotto

il riparatore

Informazioni specifiche per chi ripara il prodotto

1.	Generalità	pag. 15
2.	Descrizione del prodotto	15
3.	Impieghi	15
4.	Trasporto e immagazzinamento	16
5.	Installazione	17
6.	Messa in funzione	18
7.	Manutenzione, assistenza, ricambi	19
8.	Ricerca guasti	20
9.	Dismissione	21
10.	Tabelle e disegni	187

en WARNINGS FOR THE SAFETY OF PEOPLE AND PROPERTY

Meaning of the symbols used in this manual



DANGER

Failure to observe this warning may cause personal injury and/or damage to property



ELECTRIC SHOCK

Failure to observe this warning may result in electric shock



WARNING

Failure to observe this warning may cause damage to the pump, system, panel or environment



Read the manual carefully before proceeding

Information for :

carriers

Specific information for carriers, handlers and warehouse personnel

installers

Specific information for personnel in charge of installing the product in the system (plumbing and/or electrical aspects)

users

Specific information for users of the product

maintenance personnel

Specific information for personnel in charge of maintenance

repair personnel

Specific information for repair personnel

1.	Overview	page 22
2.	Product Description	22
3.	Applications	22
4.	Transportation and Storage	23
5.	Installation	24
6.	Start-up	25
7.	Maintenance, Service, Spare Parts	26
8.	Troubleshooting	27
9.	Disposal	28
10.	Tables and Drawings	187

1. Overview

The purpose of this manual is to provide the necessary information for proper installation, operation and maintenance of the electric pumps. The instructions and warnings provided below concern the standard version, as described in the sale documents. Special versions may be supplied with supplementary instructions leaflets. Please refer to the sale contract for any special version characteristics. Always specify the exact pump/electric pump type and identification code when requesting technical information or spare parts from our Sales and Service Department. For instructions, situations or events not considered in this manual or in the sale documents, please contact our Service Center nearest you.



Read this manual before installing and using the product.



Operating, installing and maintaining the electric pump in any way improper or that is not covered by this manual may cause personal injury and damage to property, and lead to the forfeiture of the warranty coverage.

Pay attention to possible overpressures that may result in explosions, ruptures or damages.

2. Product description

Information for installers and users

This range of cast iron submersible electric pumps includes versions with single-channel or multi-channel impeller, with "Self-cleaning" single-channel impeller (GLS) and with Vortex-type open impeller (GLV). The electric pumps have a motor with class H insulation, double mechanical seal in oil bath, power cable (10-metre long, supplied as standard), plugless. The single-phase versions are without run and start capacitors, which must be provided in the electrical control panel. All the models are equipped with a thermal probe for motor protection (→ section 5.3).

3. Applications

Information for installers and users

These electric pumps are suitable for handling sewage and wastewater and draining flooded excavations and marshy ground, with applications in the civil and industrial sectors, in building sites and agriculture.

3.1 Working limits

3.1.1 How to read the pump's rating plate

Use the electric pump following the indications reported in the dataplate. The drawings in section 10.1 show the essential data found on the rating plates.

3.1.2 Pumped liquids

These pumps are suitable for pumping the following liquids:

Series	Liquids
GLS	Clean water, water containing moderate amounts of suspended solids but no chemically aggressive substances or sand, non-aggressive, non-abrasive wastewater and sewage, particularly when containing fibrous substances
GLV	Sewage containing suspended solids and fibrous substances, or sludge with high solid content

WARNING

For maximum size of suspended solids, → section 10.6.
The density of the fluid must not exceed 1100 kg/m³ (→ section 3.1.11).
The pH of the pumped liquid must be between 5.5 and 14.



Do not use this electric pump to handle flammable, abrasive, highly corrosive and/or explosive liquids.

For special requirements, please contact our Sales and Service Department.

3.1.3 Minimum and maximum immersion depth

WARNING

Make sure that the motor is totally covered by liquid (→ section 10.7).
The maximum immersion depth must not exceed 20 metres.

3.1.4 Liquid temperature

WARNING

The maximum temperature of the liquid must not exceed +40°C.

For special requirements, please contact our Sales and Service Department.

3.1.5 Number of starts per hour

The maximum number of work cycles (starts and stops) of the electric pump is 30 per hour, evenly distributed.

3.1.6 Suction

WARNING

Make sure that the level of the liquid is never lower than the motor flange to prevent the inlet of air. The presence of air may cause damage to the electric pump and/or have an adverse effect on its performance.

Do not use the pump if cavitation occurs, as its internal components could be damaged.

3.1.7 Minimum nominal flow rate

WARNING

Do not run the pump with the on-off valve shut on the delivery side for longer than a few seconds.

3.1.8 Installation site

WARNING

Protect the electric pump from freezing temperatures.

For typical applications, a storage tank of suitable size should be provided. For additional information → section 10.8.



Do not use the electric pump in environments where chemically aggressive gases or powders may be present.

Provide adequate lighting and clearance around the electric pump. Make sure it is easily accessible for installation and maintenance operations.

3.1.9 Power supply requirements

WARNING

Make sure that the supply voltages and frequencies are suited to the characteristics of the electric motor. Refer to the pump's rating plate.

In general, the supply voltage tolerances for motor operation are as follows, if it does not run at full load:

f		UN	
Hz	~	V	± %
50	1	220	10
50	1	230	10
50	1	240	10

f		UN	
Hz	~	V	± %
50	3	380	10
50	3	400	10
50	3	415	10

3.1.10 Sound emission level

Using the electric pump totally submerged, no noise propagates to the outside.

3.1.11 Special applications

WARNING

Please contact our Sales and Service Department if :

- you must pump liquids with a density and/or viscosity value exceeding that of water as it may be necessary to install a more powerful electric pump
 - you must pump chemically treated water
- and for any situation other than the ones described, related to the nature of the liquid and/or the installation.

3.1.12 Improper use



If you use the pump/electric pump improperly, you may create dangerous conditions and cause personal injury and damage to property. Here are a few examples of improper use:

- pumping liquids that are not compatible with the pump construction materials
- pumping hazardous (toxic, explosive, corrosive) liquids
- pumping drinking liquids (wine, milk,.....)
- operating the pump in an explosive atmosphere
- installing the electric pump in a location where the fluid temperature is very high and/or there is poor ventilation
- installing the electric pump outdoors where it is not protected against freezing temperatures.
- Installing the electric pump in swimming pools or fountains.

3.2 Warranty

Please refer to the sale contract for any information.

4. Transportation and storage

information for carriers

4.1 Transportation, handling and storage of packed product

The electric pumps are packed in cartons or wooden crates having different dimensions and shapes.

WARNING

Some packages are designed to be transported, handled and stored in the vertical position. Other packages are designed to be transported, handled and stored in the horizontal position. Protect the product against humidity, dirt, heat sources, vibrations and mechanical damage (collisions, falls, ...). Do not place heavy weights on the packed products and do not stack them.



Lift and handle the product carefully, using suitable lifting equipment. Observe all the accident prevention regulations.



The electric pump must never be lifted from the motor cable.

Ambient temperature suitable for storage: ranging from -5°C to +40°C.

When you receive the electric pump, check the outside of the package for evident signs of damage. If the product bears visible signs of damage, notify our distributor within 8 days from the delivery date.

4.1.1 Additional instructions in case of storage for a long time period (more than 6 months)

Before operating the electric pump after storage, the electric pump must be inspected. Pay particular attention to the seals and the cable gland.

The impeller must be rotated every 2 months to avoid the faces of the seal to stick together.

4.2 Unpacking and handling the product

Information for installers



Use suitable handling equipment. Observe all the accident prevention regulations. Lift and handle the product carefully, using suitable lifting equipment. Use the eyebolts available on some pump models.

WARNING

Do not lift the electric pump by the motor cable.

When you receive the electric pump, check the outside of the package for evident signs of damage. Check the product for damages and for missing components. If the product bears visible signs of damage or there are missing parts, notify our distributor within 8 days from the delivery date.

4.3 Disposal of Packing Materials

If you cannot utilize the packing materials for other purposes, dispose of it according to the sorted waste disposal regulations locally in force.

5. Installation

information for installers



The installation operations must be carried out by qualified and experienced personnel. Use suitable equipment and protections. Observe the accident prevention regulations in force. Before installing the electric pump, verify that the cable and the cable gland have not been damaged during transportation. In case it's necessary to use fixing elements, check that they are correctly dimensioned, they are not corroded and they are tightened at the correct torque. In case of installation in a lifting station, install a ventilation piping. There are special requirements to be respected in case of installation in explosive atmospheres.

WARNING

Check that the piping to which the electric pump is connected do not force the electric pump.

Always refer to the local and/or national regulations, legislation and codes in force relating to the selection of the installation site and the water and power connections.

5.1 Positioning

The most common positioning methods use the lowering device for fixed installation (installation type P), or the stand for movable or semi-fixed installation (liquid transfer, draining of flooded excavations) (installation type S). Make sure that no obstructions or obstacles prevent adequate submersion and ventilation for proper motor cooling. Make sure there is adequate clearance around the pump for the maintenance operations. Carefully observe the diagrams provided in section 10.8.

5.1.1 Anchoring (for version with lowering device for fixed installation)

Anchor the coupling foot of the lowering device securely to a concrete foundation using suitable bolts. Please contact our Sales and Service Department if you need information regarding their number and size (diameter).

5.2 Selecting the delivery pipe and check valve

Use pipes suited to the maximum working pressure and flow rate of the pump. Install a non-return valve in the pipe that connects to the public/private sewer. This will prevent the backflow of the liquid. If you select a ball valve, check whether it is "sinking ball" (heavy) type or "floating ball" (lightweight) type, as the installation and operating conditions change. Do not place the valve too close to the electric pump, as the flowing liquid moved by the pump must be able to open the valve's shutter (in any case, refer to the manufacturer's instructions). Consider the flow resistance of the pipes and check valve, if present. Always refer to the local and/or national codes, regulations and standards in force.

5.3 Selecting the electric control panel

The motors must be suitably protected against overload and short circuits.

WARNING

Make sure that the panel's electric ratings match those of the electric pump. Improper combinations may cause problems and fail to guarantee the protection of the electric motor. Do not install the control panel in an explosive atmosphere or in a well.

If you use thermal relays, we recommend those that are sensitive to phase failure.

WARNING

The electric pumps are equipped as standard with a thermal sensor (normally closed) placed in the motor. The thermal contacts open at 125°C. This sensor must be powered by the electrical panel with a voltage not exceeding 250 V and a current not exceeding 4 A. It is recommended to connect the sensor with a voltage of 24 V. The sensor, when connected to a relay or contactor, makes it possible to stop the electric pump when the motor overheats (probe open).

Avoid the possibility of dry running, i.e. the pump must not run without water inside it. Make sure that the electric panel is equipped with a dry running protection system to which floats must be connected.

For the single-phase versions, make sure that the electric control panel is equipped with the run and start capacitors. As an additional safety degree, use additional control systems, like level and temperature sensors.

5.4 Selecting the float/s

Depending on the type of installation, the nature of the liquid and the national/local codes and regulations, you can select between float switches with electromechanical control and those with multiple contacts.

WARNING

Make sure that the characteristics of the float switch match those of the electric panel. Improper combinations may cause malfunctions.

Always refer to the local and/or national codes, regulations and standards in force.

6. Start-up information for installers



Use suitable handling equipment. Observe all the accident prevention regulations.

6.1 Water connection



The water connections must be made by qualified installation technicians in compliance with the regulations in force. In case of connection to the public/private sewer system, the regulations issued by the competent local authorities (municipal, public utility company,) must be observed. Piping must not force the electric pump.

Do not lift or move the electric pump by the power cable or the delivery pipe.

6.1.1 Checking the oil level

Check the oil level in the mechanical seals chamber.

6.1.2 Checking the rotation of the impeller

Remove the fuses or disconnect the electric pump from the power supply, after that make sure that the impeller rotates freely.

6.1.3 Connections

Refer to the diagrams in section 10.8. Verify the insulation resistance between the phases and the ground is more than 5 MegaOhm (5MΩ).

6.2 Electrical connection



The electrical connections must be performed by a qualified installation technician in compliance with the regulations in force. Use suitable handling equipment. Observe all the accident prevention regulations.

WARNING

Make sure that the supply voltages and frequencies are suited to the characteristics of the electric motor. Refer to the electric pumps' rating plates.

Provide suitable general protection against short circuits on the power line.



Before proceeding, make sure that all the connections (even those that are potential-free) are voltage-free.

The power supply line must be provided with the following devices (unless otherwise specified by the local regulations in force):

- A short-circuit protection device
- A high-sensitivity differential device (30mA) providing additional protection against electric shock in case the grounding system is inefficient.
- A mains isolator switch with a contact gap of at least 3 millimeters.

Ground the system according to the regulations in force. This is the first electrical connection to be performed. In case people are likely to come in contact with the electric pump or with the pumped liquids, you must provide a second ground connection.

Protect the electrical conductors from too high temperatures, liquids, vibrations and collisions.

Make sure that the electrical conductors are insulated. Risk of explosion or electric shock if the electrical connection is not correctly executed or if the product is damaged.

Connect the supply cable and the thermal sensor cable (T1 and T2) to the control panel and verify the correct operation. Refer to the diagrams in section 10.9.

6.2.1 Overload protection

WARNING

The user must provide the overload protection (thermal relay or motor protector).

Adjust the thermal relay or motor protector to the nominal current value of the electric pump or to the operating current in case the motor is not used at full load. If the motor has a star-delta starting system, adjust the thermal relay to a value equal to 58% of the nominal current or operating current.

Refer to section 5.3 for information regarding the electric panel.

6.2.2 Protection against dry running

Refer to sections 5.3 and 5.4.

6.2.3 Direction of rotation

WARNING

Reverse rotation may cause damage to the motor and the mechanical seal.

After making the electrical connection (→section 6.2), check that the direction of rotation is correct, clockwise looking the electric pump from the top to the bottom (→ section 10.10)



Do not insert hands, other body parts or tools into the suction port.

At starting stand clear of the electric pump, because the starting jerk can be powerful.

If the rotation direction is incorrect, stop the pump, disconnect the power supply and exchange the position of two phase conductors in electric panel's terminal board, if the pump is a three-phase model, or check all the connections if the pump is a single-phase model.

6.3 Operation

Normal operation requires the use of floats to control the starting and stopping of the electric pump.



WARNING

Pay attention that the electric pump may start without prior notice. Verify that the safety equipments are always active. Observe all the accident prevention regulations.

Check the current absorbed by the motor and, if necessary, adjust the setting of the thermal relay. Make sure that the level of the liquid is high enough to prevent inlet of air to the pump through the suction port.

6.4 Distance to wet areas



Risk of electrical shock when pumping near a lake, beaches, jetties, beaches or similar wet areas. There must be a safety distance of at least 20 meters between the person and the electric pump if the person is in contact with the pumped liquid. Do not use the electric pump for swimming pools or fountains.

7. Maintenance, service and spare parts

Information for maintenance personnel



Before performing any maintenance operations on the electric pump, make sure that the motor is voltage-free.



Maintenance operations must be performed by skilled, qualified and authorized personnel only. Use suitable equipment and protection devices. Observe the accident prevention regulations in force. If you need to drain the pump, make sure that the drained liquid does not cause damage or injuries.

Wait for all the components to cool down before touching it.

During maintaining and before reassembly, always remember to clean carefully all the components, in particular O-rings seats, and to replace all the O-rings, the gaskets and the sealing faces of the seals.

7.1 Routine maintenance

The pump requires a few simple routine maintenance tasks to be performed on a regular basis.

Frequency*	Operation
Within the first year of operation	Initial inspection. Ask our Sales and Service Department for a check of the electric pump conditions to determine the frequency of maintenance inspections.
At least once a year for normal applications and operation in liquids with temperature < 40°C.	Periodical inspection to avoid operation breakdowns and failures.
At least once every 3 years for normal applications and operation in liquids with temperature < 40°C.	Major inspection to ensure a long electric pump operating lifetime.

* more frequent operations may be necessary if the electric pump is used in extreme conditions, like for example pumping abrasive or corrosives solids, or liquids with temperature > 40°C.

7.1.1 Initial and periodical inspections

Component to be inspected	Operation
Electric cable	If the outer jacket is damaged, replace the cable
	Check that the cables do not have any sharp bends and are not pinched.
Electrical connections	Check that the electrical connections are properly tightened.
Electrical cabinets	Check that they are clean and dry.
Impeller	Check the impeller clearance. If necessary, adjust the impeller.
Stator casing*	Drain all liquid, if present.
Insulation	Check that the insulation resistance between the ground and the phase lead is more than 5 MΩ.
	Check the resistance between phases.
Terminal board box	Check that it is clean and dry.
Lifting device	Check that local safety regulations are followed.
Lifting handle	Check the screws. Check the conditions of the handle. Replace if necessary.
O-rings	Replace the oil plug O-rings.
	Replace the O-rings on the terminal board cover.
	Grease the new O-rings.
Personal safety devices	Check all the protections.
Rotation direction	Check the rotation direction.
Oil housing	Fill with new oil, if necessary.
Terminal board / closed end splice	Check that the connections are properly tightened.
Voltage and amperage	Check the values.

* regardless of the individual application, the inspection chamber should be inspected at least with the same frequency than the intervals for normal applications and conditions with liquids having temperature < 40°C.

7.1.2 Major inspection

In addition to the operations in section 7.1.1, follow this operations:

Component to be inspected	Operation
Motor shaft bearings	Replace the bearings with new bearings.
Mechanical seals	Replace with new mechanical seals.

7.1.3 Change the oil

Change the oil at least once a year or when the oil is dirty. Depending on the electric pump model, 1 or 2 oil plugs are present (→ section 10.12).



The oil chamber can be under pressure. Hold a rag over the oil plug to prevent oil from spraying out.

7.1.3.1 Version with 1 plug

Place the electric pump in an horizontal position with the oil plug facing upward. Unscrew the oil plug. Place a container under the electric pump, turn the electric pump and drain all the oil.

Use medical white oil of paraffin type that fulfills FDA 172.878 (a) and viscosity close to VG32. Replace the O-ring of the oil plug. Fill with oil (approximate quantity 0.6 liters). Screw and tighten the oil plug (tightening torque 10-40 Nm).

7.1.3.2 Version with 2 plugs

Place the electric pump in an horizontal position with the oil plug facing upward. Unscrew the oil plug. If the electric pump has a hole marked "oil out", it's important to use this hole to drain the oil. Place a container under the electric pump and turn the electric pump. Unscrew the other oil plug. If this hole is marked "oil in", raise the pump upright for a short period of time during drainage in order to drain all the oil.

Use medical white oil of paraffin type that fulfills FDA 172.878 (a) and viscosity close to VG32. Replace the O-rings of the oil plugs. Screw an oil plug in the hole that faces downwards or is marked "oil out", and tighten (tightening torque: 10-40 Nm). Fill with oil through the hole on the opposite side or the hole marked "oil in". If the hole is marked "oil in", slightly tilt the electric pump and lower it again in order to fill the electric pump with the correct oil quantity (approximate quantity 2 liters).

7.1.4 Checking the electric motor

If you have any doubts regarding the motor conditions, measure the isolation resistance to ground, which must exceed 5 Megaohm (MΩ). If you believe that there may be water inside the motor, please contact our Sales and Service Department.

7.1.5 Replacing the impeller

Please contact our Sales and Service Department.

7.1.6 Replacing the mechanical seals

Please contact our Sales and Service Department.

7.2 Customer service

Please contact our Sales and Service Department for any information or service you may require.

7.3 Spare parts

WARNING

Always specify the exact electric pump type and identification code when requesting technical information or spare parts from our Sales and Service Department.



Use only original spare parts to replace any worn or faulty components. The use of unsuitable spare parts may cause malfunctions, damage and injuries.

Please always refer to our Sales and Service Department for modifications on the electric pump or on the installation. Refer to the diagrams in section 10.13.

8. Troubleshooting

Information for users and maintenance personnel

PROBLEM	PROBABLE CAUSE	POSSIBLE SOLUTION
The electric pump does not start. The main switch is on.	No power supply.	Restore the power supply.
	Triggering of thermal relay or motor protector found in the electric control panel.	Reset the thermal protector.
	Pump or auxiliary circuits protection fuses blown.	Replace fuses.
	Incorrect connection to capacitors (single-phase version)	Check the connections in the electric panel
	Triggering of start/stop device (float).	Check the water level in the tank. If everything is in order, check the protection device and its connection cables.
	Triggering of protection device against dry running (float).	
	Triggering of motor thermal sensor	Wait for the pump motor to cool down.
Electric motor failure.	→section 7.1.4	
The electric pump starts up but the thermal protector is immediately	Power supply cable is damaged.	Contact our Sales and Service Department.
	Electric motor short circuit.	

triggered or the fuses blow.	Thermal protector or fuses not suited to the motor current.	Check the components and replace as necessary.
	Motor overload.	Check the operating conditions of the electric pump and reset the protection.
	Wrong rotation direction.	Check the direction of rotation and, if necessary, exchange two phases in the electrical panel if the pump is a three-phase model, or check all the connections if it is a single-phase model.
The electric pump starts up but, after a short period of time, the thermal protector is triggered or the fuses blow.	A phase in the power supply is missing.	Check the power supply.
	Power supply voltage not within the motor's working limits.	Check the operating conditions of the electric pump.
	The electric panel is situated in an excessively heated area or is exposed to direct sunlight.	Protect the panel from heat sources and from the sun.
The electric pump starts up but, after a varying period of time, the thermal protector is triggered.	There are foreign bodies (solid or fibrous substances) inside the pump, the impellers are jammed.	Extract the electric pump and clean it.
	The pump is overloaded because it is sucking a dense and viscous liquid.	Check the actual power requirements based on the characteristics of the pumped liquid.
	The temperature of the sucked liquid is too high.	Check the operating conditions of the electric pump.
	Worn motor bearings	Contact our Sales and Service Department.
The electric pump starts up but does not deliver the required flow.	Wrong rotation direction.	Check the direction of rotation and, if necessary, exchange two phases in the electrical panel if the pump is a three-phase model, or check all the connections if it is a single-phase model.
	Air in the pipes.	Bleed the air.
	Air in the pump.	Bleed the air and check the liquid level (→section 3.1.6).
	Piping and/or pump clogged.	Disassemble and clean.
	Valves locked in closed or partially closed position.	Disassemble and clean, if necessary replace the valve.
The electric pump starts up but it does not stop.	Failure of start/stop device (float).	Check the water level in the tank. If everything is in order, check the device and its connection cables.
The system's general protection cuts in.	Short circuit.	Check electrical system.
The system's differential thermal-magnetic protection cuts in.	Ground leakage.	Check insulation of the electrical system components.
The pump rotates in the wrong direction when it is stopped.	Leaks in check valve	Repair or replace the components.

9. Disposal

Information for installation and maintenance personnel



Observe the regulations and codes locally in force regarding sorted waste disposal.

10. Tabelle e disegni - Tables and Drawings - Tableaux et dessins - Tabellen und Zeichnungen - Tablas y dibujos - Tabelas e desenhos - Tabellen en tekeningen - Tabeller och ritningar - Taulukot ja kaaviot - Таблицы и чертежи - Πίνακες και σχέδια - Tabeller og tegninger - Tabeller og tegninger - Tabele i rysunki - Tabulky a schémata - Tabuľky a nákresy - Táblázatok és ábrák - Tabele in risbe - Tabele și desene - Таблицы и схеми - Tablolar ve çizimler - Таблиці й креслення - الجداول والتصميمات

10.1 Come leggere la targa dati - How to Read the Rating Plate - Comment lire la plaque des données - Lesen des Datenschildes - Cómo leer la placa de características - Como ler a placa dos dados - Wijze waarop het typeplaatje gelezen moet worden - Pumpens märklåt - Pumpun arvokilven tulkinta - Как читать табличку данных - Πώς διαβάζεται η πινακίδα στοιχείων - Læsning af typeskilt - Hvordan lese dataskiltet - Jak czytać tabliczkę znamionową - Jak číst identifikační štítek - Ako čítať identifikačný štítok čerpadla - Hogyan kell az adattáblát értelmezni - Razlaga tablice s podatki - Cum se citește plăcuța indicatoare - Разчитане на табелката с техническите данни - Veri plakasını nasıl okumak gerekir - Як читати табличку даних - كيفية قراءة لوحة البيانات

10.1.1 Prodotto standard - Standard product - Produit standard - Standardprodukt - Producto estándar - Produto standard - Standaard product - Standardprodukt - Vakiolaite - Стандартное изделие - Προϊόν στάνταρ - Standard apparat - Standardapparat - Produkt standardowy - Standardní výrobek - Štandardný výrobok - Szabvány termék - Standardni izdelek - Produsul standard - Стандартен модел - Standart ürün - Стандартий виріб - المنتج المعياري

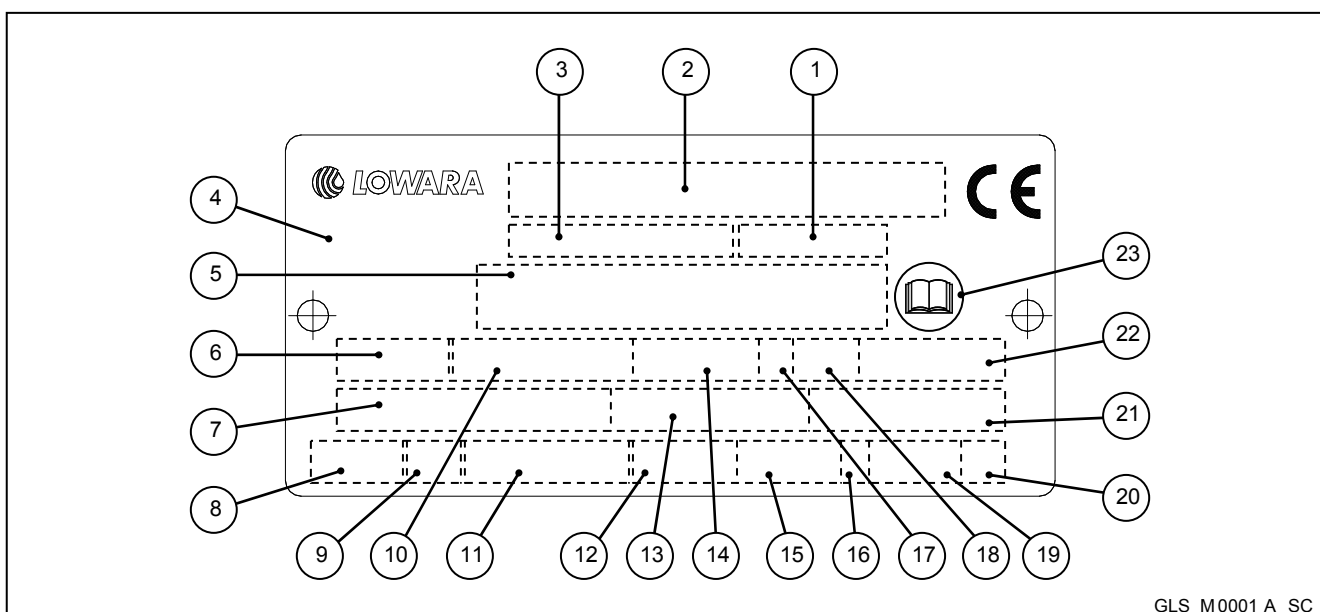

GLS_M0001_A_SC

1	Codice curva prestazioni
2	Numero di serie (con anno di produzione)
3	Codice elettropompa
4	Paese di origine
5	Denominazione elettropompa / informazioni addizionali
6	Fasi; tipo di corrente; frequenza
7	Tensione nominale
8	Protezione termica
9	Classe termica
10	Potenza nominale all'albero
11	Standard internazionale
12	Grado di protezione
13	Corrente nominale
14	Velocità nominale
15	Profondità massima d'immersione
16	Direzione di rotazione: L = sinistra, R = destra
17	Classe di carico
18	Fattore di carico
19	Peso elettropompa
20	Lettera codice rotore bloccato
21	Fattore di potenza
22	Massima temperatura ambiente (°C)
23	Fate riferimento al manuale d'istruzioni

1	Performance curve code
2	Serial number (with year of manufacture)
3	Electric pump code
4	Country of origin
5	Electric pump denomination / additional information
6	Phase; current type; frequency
7	Rated voltage
8	Thermal protection
9	Thermal class
10	Rated shaft power
11	International standard
12	Degree of protection
13	Rated current
14	Rated speed
15	Maximum submergence
16	Direction of rotation: L = Left, R = Right
17	Duty class
18	Duty factor
19	Product weight
20	Locked rotor code letter
21	Power factor
22	Maximum ambient temperature (°C)
23	Refer to installation manual

1	Code courbe caractéristique
2	Numéro de matricule (avec année de fabrication)
3	Référence électropompe
4	Pays d'origine
5	Dénomination électropompe / informations complémentaires
6	Phases ; type de courant ; fréquence
7	Tension nominale
8	Protection thermique
9	Classe thermique
10	Puissance nominale à l'arbre
11	Standard international
12	Degré de protection
13	Courant nominal
14	Vitesse nominale
15	Profondeur maximum d'immersion
16	Direction de rotation : L = gauche, R = droite
17	Classe de service
18	Facteur de service
19	Poids électropompe
20	Lettre code rotor bloqué
21	Facteur de puissance
22	Température ambiante maximum (°C)
23	Se référer au manuel d'instructions

1	Kennlinien Code
2	Seriennummer (mit Produktionsjahr)
3	Code Motorpumpe
4	Herkunftsland
5	Bezeichnung Motorpumpe / Zusätzliche Informationen
6	Phasen; Stromart; Frequenz
7	Nennspannung
8	Thermoschutz
9	Wärmeklasse
10	Nennleistung an der Welle
11	Internationaler Standard
12	Schutzart
13	Nennstrom
14	Nenngeschwindigkeit
15	Maximale Eintauchtiefe
16	Drehrichtung: L = links, R = rechts
17	Lastklasse
18	Lastfaktor
19	Gewicht Motorpumpe
20	Code-Buchstabe für blockierten Rotor
21	Leistungsfaktor
22	Maximale Umgebungstemperatur (°C)
23	Beziehen Sie sich auf die Betriebsanleitung

1	Código de la curva de prestaciones
2	Número de serie (con año de producción)
3	Código de la electrobomba
4	País de origen
5	Denominación de la electrobomba / información adicional
6	Fases; tipo de corriente; frecuencia
7	Tensión nominal
8	Protección térmica
9	Clase térmica
10	Potencia nominal en el eje
11	Estándar internacional
12	Grado de protección
13	Corriente nominal
14	Velocidad nominal
15	Profundidad máxima de inmersión
16	Dirección de rotación: L = izquierda, R = derecha
17	Clase de carga
18	Factor de carga
19	Peso de la electrobomba
20	Letra código rotor bloqueado
21	Factor de potencia
22	Temperatura ambiente máxima (°C)
23	Hacer referencia al manual de instrucciones

1	Código curva rendimentos
2	Número de série (com ano de fabrico)
3	Código da electrobomba
4	País de origem
5	Denominação da electrobomba/ informações adicionais
6	Fases; tipo de corrente; frequência
7	Tensão nominal
8	Protecção térmica
9	Classe térmica
10	Potência nominal do veio
11	Padrão internacional
12	Grau de protecção
13	Corrente nominal
14	Velocidade nominal
15	Profundidade máxima de imersão
16	Sentido de rotação: L = esquerda, R = direita
17	Classe de carga
18	Factor de carga
19	Peso da electrobomba
20	Letra código rotor bloqueado
21	Factor de potência
22	Temperatura ambiente máxima (°C)
23	Ter como referência o manual de instruções

1	Code prestatiecurve
2	Seriennummer (met productiejaar)
3	Code elektropomp
4	Land van herkomst
5	Benaming elektropomp / aanvullende informatie
6	Fases; type stroom; frequentie
7	Nominale spanning
8	Thermische beveiliging
9	Thermische klasse
10	Nominaal asvermogen
11	Internationale standaard
12	Beschermingsgraad
13	Nominale stroom
14	Nominale snelheid
15	Maximum dompeldiepte
16	Draairichting: L = links, R = rechts
17	Belastingsklasse

1	Kod prestationskurva (blandade)
2	Seriennummer (med tillverkningsår)
3	Kod för elpump
4	Ursprungsland
5	Elpumpens benämning/extra information
6	Faser, strömtyper, frekvens
7	Märkspänning
8	Överhettningsskydd
9	Värmeklass
10	Märkaxeffekt
11	International standard
12	Skyddsgrad
13	Märkström
14	Märkvarvtal
15	Maximal nedsänkning
16	Rotationsriktning: L = vänster, R = höger
17	Driftklass

18	Belastingsfactor
19	Gewicht elektropomp
20	Codeletter rotor geblokkeerd
21	Vermogensfactor
22	Maximum omgevingstemperatuur (°C)
23	Zie de instructiehandleiding

1	Tehokäyrän koodi
2	Sarjanumero (ja valmistusvuosi)
3	Sähköpumpun koodi
4	Alkuperämaa
5	Sähköpumpun nimike / lisätietoja
6	Vaiheet; virtatyyppi; taajuus
7	Nimellisjännite
8	Ylikuormasuoja
9	Lämpöluokka
10	Akselin nimellisteho
11	Kansainvälinen standardi
12	Suoja-aste
13	Nimellisvirta
14	Nimellisnopeus
15	Maksimiupotussyvyys
16	Ryörimissuunta: L = vasemmalle, R = oikealle
17	Käyttöluokka
18	Toimintasuhde
19	Sähköpumpun paino
20	Jumiutuneen roottorin koodikirjain
21	Tehokerroin
22	Ympäriöivä maks.lämpötila (°C)
23	Katso käyttöopas

1	Κωδικός καμπύλης επιδόσεων
2	Αριθμός σειράς (με έτος παραγωγής)
3	Κωδικός ηλεκτρικής αντλίας
4	Χώρα προέλευσης
5	Ονομασία ηλεκτρικής αντλίας / πρόσθετες πληροφορίες
6	Φάσεις; τύπος ρεύματος, συχνότητα
7	Ονομαστική τάση
8	Θερμική προστασία
9	Θερμική κατηγορία
10	Ονομαστική ισχύς του άξονα
11	Διεθνές στάνταρ
12	Βαθμός προστασίας
13	Ονομαστικό ρεύμα
14	Ονομαστική ταχύτητα
15	Μέγιστο βάθος βύθισης
16	Κατεύθυνση περιστροφής: L = αριστερά, R = δεξιά
17	Κατηγορία φορτίου
18	Παράγοντας φορτίου
19	Βάρος ηλεκτρικής αντλίας
20	Γράμμα κωδικού μπλοκαρισμένης πτερωτής
21	Παράγοντας ισχύος
22	Μέγιστη θερμοκρασία περιβάλλοντος (°C)
23	Ανατρέξτε στο εγχειρίδιο οδηγιών

1	Kode for belastningskurve
2	Serienummer (med produktionsår)
3	Kode for elektropumpe
4	Opplinnelsesland
5	Betegnelse for elektropumpe/ekstra opplysninger
6	Faser, strømtype, frekvens
7	Nominell spenning
8	Varmevern
9	Varmeklasse

18	Driftfaktor
19	Produktvikt
20	Kodbokstav blockerad rotor
21	Effektfaktor
22	Maximal omgivningstemperatur (°C)
23	Se bruksanvisningen

1	Код графика эксплуатационных характеристик
2	Серийный номер (с годом производства)
3	Код электронасоса
4	Страна происхождения
5	Наименование электронасоса / дополнительная информация
6	Фазы; тип тока; частота
7	Номинальное напряжение
8	Температурная защита
9	Класс температуры
10	Номинальная мощность вала
11	Международный стандарт
12	Степень защиты
13	Номинальный ток
14	Номинальная скорость
15	Максимальная глубина погружения
16	Направление вращения: L = левое, R = правое
17	Класс использования
18	Коэффициент использования
19	Вес электронасоса
20	Буква кода заблокированного ротора
21	Коэффициент мощности
22	Максимальная температура окружающей среды (°C)
23	См. рабочее руководство

1	Kode for belastningskurve
2	Serienummer (med produktionsår)
3	Kode for elektropumpe
4	Oprindelsesland
5	Betegnelse for elektropumpe/ekstra oplysninger
6	Faser, strømtype, frekvens
7	Nominel spænding
8	Termisk beskyttelse
9	Termisk klasse
10	Nominel effekt ved akslen
11	International standard
12	Beskyttelsesgrad
13	Nominel strøm
14	Nominel hastighed
15	Maks. nedsænkingsdybde
16	Rotationsretning: L = venstre, R = højre
17	Belastningsklasse
18	Belastningsfaktor
19	Elektropumpens vægt
20	Bogstavkode for blokeret rotor
21	Effektfaktor
22	Maks. omgivelsestemperatur (°C)
23	Se manualen

1	Kod krzywej osiągow
2	Numer fabryczny (z rokiem produkcji)
3	Kod elektropompy
4	Państwo pochodzenia
5	Nazwa elektropompy / informacje dodatkowe
6	Fazy; typ prądu; częstotliwość
7	Napięcie nominalne
8	Ochrona termiczna
9	Klasa termiczna

10	Nominell effekt ved akselen
11	Internasjonal standard
12	Beskyttelsesgrad
13	Nominell strøm
14	Nominell hastighet
15	Maks. nedsenkingsdybde
16	Rotasjonsretning: L = venstre, R = høyre
17	Belastningsklasse
18	Belastningsfaktor
19	Elektropumpens vekt
20	Bokstavkode for blokkert rotor
21	Effektfaktor
22	Maks. omgivelsestemperatur (°C)
23	Se håndboken

10	Moc nominalna na wale
11	Standard międzynarodowy
12	Stopień ochrony
13	Prąd nominalny
14	Prędkość nominalna
15	Maksymalna głębokość zanurzenia
16	Kierunek obrotu: L = lewy, R = prawy
17	Klasa obciążenia
18	Współczynnik obciążenia
19	Ciężar elektropompy
20	Litera kodu zablokowanego rotora
21	Współczynnik mocy
22	Maksymalna temperatura otoczenia (°C)
23	Odnieść się do podręcznika instrukcji

1	Kód výkonová křivka
2	Výrobní číslo (s rokem výroby)
3	Kód elektročerpadla
4	Země původu
5	Název elektročerpadla / další informace
6	Fáze; typ proudu; kmitočet
7	Jmenovité napětí
8	Tepelná ochrana
9	Tepelná třída
10	Jmenovitý výkon na hřídeli
11	Mezinárodní standard
12	Stupeň krytí
13	Jmenovitý proud
14	Jmenovitá rychlost
15	Maximální hloubka ponoru
16	Směr otáčení: L = doleva, R = doprava
17	Třída zatížení
18	Zatěžovatel
19	Váha elektročerpadla
20	Kód zablokovaného rotoru
21	Účinník
22	Maximální teplota okolního prostředí (°C)
23	Viz návod k používání

1	Kód výkonovej krivky
2	Výrobné číslo (s rokom výroby)
3	Kód elektrického čerpadla
4	Krajina pôvodu
5	Názov elektrického čerpadla / ďalšie informácie
6	Fázy; typ prúdu; kmitočet
7	Menovité napätie
8	Tepelná ochrana
9	Tepelná trieda
10	Menovitý výkon na hriadeli
11	Medzinárodný štandard
12	Stupeň ochrany
13	Menovitý prúd
14	Menovitá rýchlosť
15	Maximálna hĺbka ponoru
16	Smer otáčania: L = doľava, R = doprava
17	Trieda zaťaženia
18	Zaťažovateľ
19	Hmotnosť elektrického čerpadla
20	Kód zablokovaného rotoru
21	Účinník
22	Maximálna teplota okolitého prostredia (°C)
23	Odkazujeme na návod na použitie

1	Teljesítménygörbe kódszám
2	Sorozatszám (gyártási évvel)
3	Elekromos szivattyú kódszám
4	Származási ország
5	Elekromos szivattyú elnevezés / kiegészítő információk
6	Fázis; áram típus; frekvencia
7	Névleges feszültség
8	Hővédelem
9	Hő osztály
10	Névleges teljesítmény a tengelynél
11	Nemzetközi szabvány
12	Védelmi fok
13	Névleges áram
14	Névleges sebesség
15	Maximális merülési mélység
16	Forgási irány: L = bal, R = jobb
17	Terhelési osztály
18	Terhelési tényező
19	Elekromos szivattyú súly
20	Leblokkolt forgórész kódszám betű
21	Teljesítmény tényező
22	Maximális környezeti hőmérséklet (°C)
23	A használati kézikönyvet vegye hivatkozásul

1	Koda krivulje zmogljivosti
2	Serijska številka (z letom izdelave)
3	Koda električne črpalke
4	Država izdelave
5	Naziv električne črpalke / dodatne informacije
6	Faze, vrsta toka, frekvenca
7	Nazivna napetost
8	Toplotna zaščita
9	Razred toplotne zaščite
10	Nazivna moč na gredi
11	Mednarodni standard
12	Razred zaščite
13	Nazivni tok
14	Nazivna hitrost
15	Največja globina potopitve
16	Smer vrtenja L = levo, R = desno
17	Razred obremenitev
18	Faktor obremenitve
19	Teža električne črpalke
20	Črka kode blokiranega rotorja
21	Faktor moči
22	Najvišja temperatura okolja (°C)
23	Glejte priročnik z navodili

1	Cod curbă caracteristică
2	Număr de serie (cu anul de fabricație)
3	Cod electropompă

1	Код на работния капацитет
2	Сериен номер (година на производство)
3	Код на електропомпата

4	Țara de origine
5	Denumirea electropompei/informații suplimentare
6	Faze; tip de curent; frecvență
7	Tensiune nominală
8	Protecție termică
9	Clasă termică
10	Putere nominală la arbore
11	Standard internațional
12	Grad de protecție
13	Curent nominal
14	Viteză nominală
15	Adâncime maximă de imersiune
16	Direcție de rotație: L = stânga, R = dreapta
17	Clasă de sarcină
18	Factor de sarcină
19	Greutate electropompă
20	Literă cod rotor blocat
21	Factor de putere
22	Temperatură ambiantă maximă (°C)
23	A se vedea manualul de instrucțiuni

1	Performans eğrisi kodu
2	Seri numarasi (ve imalat yılı)
3	Elektrikli pompa kodu
4	Üretim ülkesi
5	Elektrikli pompa adı / ek bilgiler
6	Fazlar; akım tipi; frekans
7	Nominal gerilim
8	Termik koruma
9	Isı sınıfı
10	Milde ölçülen nominal güç
11	Uluslararası standart
12	Koruma derecesi
13	Nominal akım
14	Nominal hız
15	Maksimum daldırma derinliği
16	Dönüş istikameti: L = sol, R = sağ
17	Yük sınıfı
18	Yük faktörü
19	Elektrikli pompa ağırlığı
20	Tıkalı rotor kod harfi
21	Güç faktörü
22	Maksimum ortam sıcaklığı (°C)
23	Talimat el kitabına bakınız

1	كود منحني الأداء
2	الرقم التسلسلي (مع سنة الإنتاج)
3	كود المضخة الكهربائية
4	بلد المنشأ
5	تسمية المضخة الكهربائية / معلومات إضافية
6	المراحل، نوع التيار، التردد
7	قيمة الجهد الاسمية
8	حماية حرارية
9	فئة حرارية
10	القدرة الاسمية لعمود الدوران
11	المعيار الدولي
12	درجة الحماية
13	قيمة التيار الاسمية
14	قيمة السرعة الاسمية
15	أقصى عمق للغمر
16	اتجاه الدوران: R = يمين، L = يسار
17	درجة الشحن
18	معامل الشحن

4	Държава производител
5	Наименование на помпата/ допълнителна информация
6	Фази; вид на тока; честота
7	Номинално напрежение
8	Термозащитата
9	Термоклас
10	Номинална мощност на вала
11	Интернационален стандарт
12	Степен на защитата
13	Номинален ток
14	Номинална скорост
15	Максимална дълбочина на потапяне
16	Посока на ротация; L = дясно, R = ляво
17	Клас на натоварване
18	Фактор на натоварване
19	Тегло на електропомпата
20	Буквен код при блокиране на ротора
21	Фактор на мощност
22	Максимална температура на средата (°C)
23	За справка използвайте ръководството

1	Код кривої експлуатаційних характеристик
2	Серійний номер (з роком виробництва)
3	Код електронасоса
4	Країна походження
5	Найменування електронасоса/додаткова інформація
6	Фази; тип струму; частота
7	Номінальна напруга
8	Термозахист
9	Термічний клас
10	Номінальна потужність на валу
11	Міжнародний стандарт
12	Ступінь захисту
13	Номінальний струм
14	Номінальна швидкість
15	Максимальна глибина занурення
16	Напрямок обертання: L = вліво, R = вправо
17	Клас навантаження
18	Коефіцієнт навантаження
19	Вага електронасоса
20	Кодова буква блокуваного ротора
21	Коефіцієнт потужності
22	Максимальна температура навколишнього середовища (°C)
23	Керуйтеся інструкціями з використання й обслуговування

19	وزن المضخة الكهربائية
20	حرف رمزي لدوار مغلق
21	معامل القدرة
22	أقصى درجة حرارة للمكان (درجة مئوية)
23	ارجع إلى كتيب التعليمات

10.2 Denominazione di prodotto - Product denomination - Caractéristiques du produit - Produktbezeichnung - Denominación del producto - Denominação do produto - Productbenaming - Produktbenämning - Laitteen nimike - Наименование изделия - Ονομασία προϊόντος - Apparätets betegnelse - Apparätets betegnelse - Nazwa produktu - Název výrobku - Název výrobku - A termék elnevezése - Naziv izdelka - Denumirea produsului - Наименование на изделието - Ürün adı - Найменування продукту - تسمية المنتج

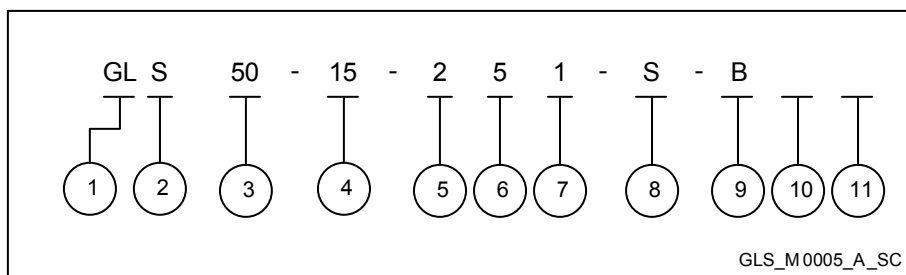

1	Nome serie
2	Tipo girante
3	Diametro nominale di mandata [mm]
4	Potenza all'albero P ₂ x 10 [kW]
5	Numero di poli
6	Frequenza / 10 [Hz]
7	Fasi
8	Connessione di mandata Flangiata P Kit di discesa S Filettata
9	Tensione 400 V (3~) – 230 V (1~) A 380 V (3~) – 220 V (1~) B 415 V (3~) – 240 V (1~)
10	Versione pompa Standard
11	Lunghezza cavo 10 metri 2 20 metri

1	Name of the series
2	Type of impeller
3	Nominal diameter of discharge [mm]
4	Shaft power P ₂ x 10 [kW]
5	Number of poles
6	Frequency / 10
7	Phases
8	Discharge connection Flanged P Sliding kit S Threaded
9	Voltage 400 V (3~) – 230 V (1~) A 380 V (3~) – 220 V (1~) B 415 V (3~) – 240 V (1~)
10	Pump version Standard
11	Cable length 10 meters 2 20 meters

1	Dénomination série
2	Type de roue
3	Diamètre nominal de refoulement [mm]
4	Puissance à l'arbre P ₂ x 10 [kW]
5	Nombre de pôles
6	Fréquence / 10 [Hz]
7	Phases
8	Raccordement de refoulement À bride P Kit de calage S Fileté
9	Tension 400 V (3~) – 230 V (1~) A 380 V (3~) – 220 V (1~) B 415 V (3~) – 240 V (1~)
10	Version pompe Standard
11	Longueur câble 10 mètres 2 20 mètres

1	Name der Baureihe
2	Laufradtyp
3	Nenn Durchmesser der Ausflussleitung [mm]
4	Wellenleistung P ₂ x 10 [kW]
5	Anzahl an Polen
6	Frequenz / 10 [Hz]
7	Phasen
8	Ausflussanschluss Flanged P Bausatz Senkvorrichtung S Gewinde
9	Spannung 400 V (3~) – 230 V (1~) A 380 V (3~) – 220 V (1~) B 415 V (3~) – 240 V (1~)
10	Pumpenausführung Standard
11	Kabellänge 10 meters 2 20 Meter

1	Nombre de la serie
2	Tipo de rodete
3	Diámetro nominal de impulsión [mm]
4	Potencia en el eje P ₂ x 10 [kW]
5	Número de polos
6	Frecuencia / 10 [Hz]
7	Fases
8	Conexión de impulsión Embridada P Kit de descenso S Roscada
9	Tensión 400 V (3~) – 230 V (1~) A 380 V (3~) – 220 V (1~) B 415 V (3~) – 240 V (1~)
10	Versión de la bomba Estándar
11	Longitud del cable 10 metros 2 20 metros

1	Nome da série
2	Tipo de impulsor
3	Diâmetro nominal de compressão [mm]
4	Potência no veio P ₂ x 10 [kW]
5	Número de pólos
6	Frequência / 10 [Hz]
7	Fases
8	Ligação de compressão Com flange P Kit de descida S Roscada
9	Tensão 400 V (3~) – 230 V (1~) A 380 V (3~) – 220 V (1~) B 415 V (3~) – 240 V (1~)
10	Versão da bomba Standard
11	Comprimento do cabo 10 metros 2 20 metros

1	Serienaaam
2	Type waaier
3	Nominale diameter pers aansluiting [mm]
4	Asvermogen P ₂ x 10 [kW]
5	Aantal polen
6	Frequentie / 10 [Hz]
7	Fases
8	Pers aansluiting Geflensd P Neerlaatset S Met draad
9	Spanning 400 V (3~) – 230 V (1~) A 380 V (3~) – 220 V (1~) B 415 V (3~) – 240 V (1~)
10	Pompversie Standaard
11	Kabellengte 10 meter 2 20 meter

1	Serienamn
2	Typ av pumphjul
3	Nominell diameter för utlopp [mm]
4	Axeleffekt P ₂ x 10 [kW]
5	Antal poler
6	Frekvens / 10
7	Faser
8	Utloppsanslutning Flänsad P Glidsats S Gängad
9	Spänning 400 V (3~) – 230 V (1~) A 380 V (3~) – 220 V (1~) B 415 V (3~) – 240 V (1~)
10	Pumpversion Standard
11	Kabellängd 10 meter 2 20 meter

1	Sarjanimi
2	Juoksupyörän tyyppi
3	Poistoaukon nimellishalkaisija (mm)
4	Akselin teho P ₂ x 10 (kW)
5	Napamäärä
6	Taajuus / 10 (Hz)
7	Vaiheet
8	Poistoliitin Laipoitettu P Laskusarja S Kierteinen
9	Jännite 400 V (3~) – 230 V (1~) A 380 V (3~) – 220 V (1~) B 415 V (3~) – 240 V (1~)
10	Pumpun versio Vakio
11	Kaapelin pituus 10 m 2 20 m

1	Название серии
2	Тип крыльчатки
3	Номинальный диаметр подачи [мм]
4	Мощность вала P ₂ x 10 [кВт]
5	Число полюсов
6	Частота / 10 [Гц]
7	Фазы
8	Соединение подачи Фланцевое P Комплект спуска S Резьбовой
9	Напряжение 400 V (3~) – 230 V (1~) A 380 V (3~) – 220 V (1~) B 415 V (3~) – 240 V (1~)
10	Модель насоса Стандартная
11	Длина кабеля 10 метров 2 20 метров

1	Όνομα σειράς
2	Τύπος πτερωτής
3	Όνομαστική διάμετρος παροχής [mm]
4	Ισχύς του άξονα P ₂ x 10 [kW]
5	Αριθμός πόλων
6	Συχνότητα / 10 [Hz]
7	Φάσεις
8	Σύνδεση παροχής Με φλάντζα P Kit καθόδου S Με σπείρωμα
9	Τάση 400 V (3~) – 230 V (1~) A 380 V (3~) – 220 V (1~) B 415 V (3~) – 240 V (1~)
10	Έκδοση αντλίας Στάνταρ
11	Μήκος καλωδίου 10 μέτρα 2 20 μέτρα

1	Serienavn
2	Pumpehjulstype
3	Nominal diameter for trykside (mm)
4	Effekt ved akslen P ₂ x 10 (kW)
5	Antal poler
6	Frekvens / 10 (Hz)
7	Faser
8	Tryktilslutning Med flange P Sænkeudstyr S Med gevind
9	Spænding 400 V (3~) – 230 V (1~) A 380 V (3~) – 220 V (1~) B 415 V (3~) – 240 V (1~)
10	Pumpeversion Standard
11	Kabellængde 10 m 2 20 m

1	Serienummer
2	Type pumpehjul
3	Nominell diameter for trykkside (mm)
4	Effekt ved akselen P ₂ x 10 (kW)
5	Antall poler
6	Frekvens/10 (Hz)
7	Faser
8	Tryktilkopling Flenset P Senkeutstyr S Gjenget
9	Spenning 400 V (3~) – 230 V (1~) A 380 V (3~) – 220 V (1~) B 415 V (3~) – 240 V (1~)
10	Pumpeutgave Standard
11	Kabellengde 10 meter 2 20 meter

1	Nazwa serii
2	Typ wirnika
3	Średnica nominalna strony tłocznej [mm]
4	Moc na wale P ₂ x 10 [kW]
5	Liczba biegunów
6	Częstotliwość / 10 [Hz]
7	Fazy
8	Podłączenie strony tłocznej Kołnierzowe P Zestaw opuszczania S Nagwintowane
9	Napięcie 400 V (3~) – 230 V (1~) A 380 V (3~) – 220 V (1~) B 415 V (3~) – 240 V (1~)
10	Wersja pompy Standard
11	Długość kabla 10 metrów 2 20 metrów

1	Názov série
2	Typ oběžného kola
3	Jmenovitý průměr přívodního potrubí [mm]
4	Výkon hřídele P ₂ x 10 [kW]
5	Počet pólů
6	Kmitočet / 10 [Hz]
7	Fáze
8	Připojení přívodního potrubí S přírubou P S klesající soupravou S Závitové
9	Napětí 400 V (3~) – 230 V (1~) A 380 V (3~) – 220 V (1~) B 415 V (3~) – 240 V (1~)
10	Verze čerpadla Standard
11	Délka kabelu 10 metrů 2 20 metrů

1	Názov série
2	Typ obežného kolesa
3	Menovitý priemer prírodného potrubia [mm]
4	Výkon hriadeľa P ₂ x 10 [kW]
5	Počet pólů
6	Kmitočet / 10 [Hz]
7	Fázy
8	Připojení přírodného potrubia S přírubou P S klesající soupravou S Závitové
9	Napätie 400 V (3~) – 230 V (1~) A 380 V (3~) – 220 V (1~) B 415 V (3~) – 240 V (1~)
10	Verzia čerpadla Štandard
11	Dĺžka kábla 10 metrov 2 20 metrov

1	Sorozat neve
2	Járókerék típus
3	Odairányú névleges átmérő [mm]
4	Teljesítmény a tengelynél $P_2 \times 10$ [kW]
5	Pólusok száma
6	Frekvencia / 10 [Hz]
7	Fázisok
8	Odairányú csatlakozás Karimázás P Leeresztő készlet S Menetezés
9	Feszültség 400 V (3~) – 230 V (1~) A 380 V (3~) – 220 V (1~) B 415 V (3~) – 240 V (1~)
10	Szivattyú változat Szabvány
11	Vezeték hossz 10 méter 2 20 méter

1	Ime serije
2	Tip rotorja
3	Nazivni premer tlačne cevi [mm]
4	Moč na gredi $P_2 \times 10$ [kW]
5	Število polov
6	Frekvenca / 10 [Hz]
7	Faze
8	Tlačni priključek Prirobnica P Komplet za spuščanje S Navojna
9	Napetost 400 V (3~) – 230 V (1~) A 380 V (3~) – 220 V (1~) B 415 V (3~) – 240 V (1~)
10	Različica črpalke Standard
11	Dolžina kabla 10 metrov 2 20 metrov

1	Denumire serie
2	Tip rotor
3	Diametru nominal refulare [mm]
4	Putere la arbore $P_2 \times 10$ [kW]
5	Număr poli
6	Frecvență / 10 [Hz]
7	Faze
8	Racord refulare Cu flanșă P Kit coborâre S Cu filet
9	Tensiune 400 V (3~) – 230 V (1~) A 380 V (3~) – 220 V (1~) B 415 V (3~) – 240 V (1~)
10	Varianta pompă Standard
11	Lungime cablu 10 metri 2 20 metri

1	Серия
2	Вид витло
3	Номинален диаметър на изтласкване [mm]
4	Мощност на вала $P_2 \times 10$ [kW]
5	Брой на полюсите
6	Честота / 10 [Hz]
7	Фази
8	Отводна връзка Фланцова P Оборудване за потапяне S Резбована
9	Напрежение 400 V (3~) – 230 V (1~) A 380 V (3~) – 220 V (1~) B 415 V (3~) – 240 V (1~)
10	Вариант на помпата Стандартен
11	Дължина на кабела 10 метра 2 20 метра

1	Ürün serisi adı
2	Fan tipi
3	Basma borusunun nominal çapı [mm]
4	Milde ölçülen güç $P_2 \times 10$ [kW]
5	Kutup sayısı
6	Frekans / 10 [Hz]
7	Fazlar
8	Basma borusu bağlantısı Flanşlı P İndirme kiti S Vida dişli
9	Gerilim 400 V (3~) – 230 V (1~) A 380 V (3~) – 220 V (1~) B 415 V (3~) – 240 V (1~)
10	Pompa versiyonu Standart
11	Kablo uzunluğu 10 metre 2 20 metre

1	Найменування серії
2	Тип крильчатки
3	Номинальний діаметр подачі [мм]
4	Потужність на валу $P_2 \times 10$ [кВт]
5	Кількість полюсів
6	Частота / 10 [Гц]
7	Фази
8	З'єднання для подачі Фланцова P Набір для зниження/спуску S Різьбове
9	Напруга 400 V (3~) – 230 V (1~) A 380 V (3~) – 220 V (1~) B 415 V (3~) – 240 V (1~)
10	Версія насоса Стандартна
11	Довжина кабелю 10 метрів 2 20 метрів

1	اسم مجموعة المنتجات
2	نوع الوحدة الدوارة
3	القيمة الاسمية لقطر التدفق الخارج [مم]
4	قدرة العمود الدوار [$P_2 \times 10$ كيلو وات kW]

5	عدد الأقطاب
6	التردد / 10 [هرتز] [Hz]
7	مراحل
8	توصيل التدفق الخارج الحافة الخارجية P معدات الإنزال S قلاووظ
9	الجهد 400 V (3~) – 230 V (1~) A 380 V (3~) – 220 V (1~) B 415 V (3~) – 240 V (1~)
10	نوع المضخة المعيارية
11	طول الكابل 10 أمتار 2 متر

10.3 Denominazione di vendita - Sales denomination - Dénomination de vente - Handelsbezeichnung - Denominación de venta - Denominação de venda - Verkoopbenaming - Försäljningsbeteckning - Myyntinimike - Наименование продажи - Ονομασία πώλησης - Salgsbetegnelse - Salgsbetegnelse - Nazwa handlowa - Prodejní název - Predajný názov - Értékesítési elnevezés - Prodajni naziv - Denumirea de vânzare - Търговско наименование - Satış bilgileri - Комерційне найменування - تسمية المنتج للبيع

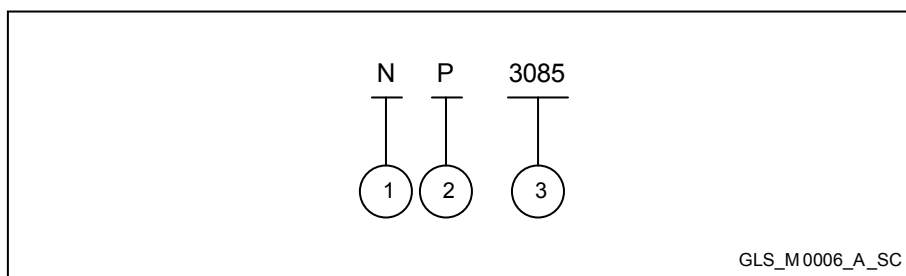

1	Tipo di idraulica
2	Tipo di installazione
3	Codice di vendita

1	Hydraulic part
2	Installation type
3	Sales code

1	Type de partie hydraulique
2	Type d'installation
3	Référence de vente

1	Hydraulikteile
2	Installationsart
3	Handelscode

1	Tipo de hidráulica
2	Tipo de instalación
3	Código de venta

1	Tipo de hidráulica
2	Tipo de instalação
3	Código de venda

1	Hydraulisch onderdeel
2	Type installatie
3	Verkoopcode

1	Hydraulisk del
2	Installationstyp
3	Försäljningskod

1	Hydrauliosan tyyppi
2	Asennustyyppi
3	Myyntikoodi

1	Тип гидравлической части
2	Тип установки
3	Код продажи

1	Τύπος υδραυλικών
2	Τύπος εγκατάστασης
3	Κωδικός πώλησης

1	Type hydraulisk del
2	Installationstype
3	Salgskode

1	Type hydraulisk del
2	Installasjonstype
3	Salgskode

1	Typ hydrauliki
2	Typ instalacji
3	Kod sprzedaży

1	Typ hydrauliky
2	Typ montáže
3	Prodejní kód

1	Typ hydrauliky
2	Typ montáže
3	Predajný kód

1	Hidraulika típus
2	Telepítési típus
3	Értékesítési kódszám

1	Tip hidravlike
2	Tip montaže
3	Prodajna koda

1	Tip parte hidraulică
2	Tip instalare
3	Cod vânzare

1	Вид на хидравликата
2	Вид на исталацията
3	Търговски код

1	Su hidroliği tipi
2	Tesisat tipi
3	Satış kodu

1	Тип гидравліки
2	Тип установки
3	Код продажу

1	النوع الهيدروليكي
2	نوع التثبيت
3	كود البيع

10.4 Codice prodotto - Product code - Référence produit - Produktcode - Código del producto - Código do produto - Productcode - Produktkod - Laitteen koodi - Код изделия - Κωδικός προϊόντος - Kode for apparat - Apparatkode - Kod produktu - Kód výrobku - Kód výroby - Termék kódszám - Koda izdelka - Codul produsului - Код на изделието - Ürün kodu - Код виробу - كود المنتج

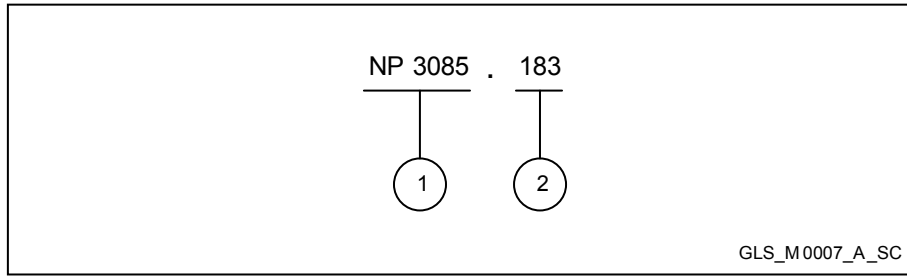

1	Denominazione di vendita
2	Versione

1	Sales denomination
2	Version

1	Dénomination de vente
2	Version

1	Handelsbezeichnung
2	Ausführung

1	Denominación de venta
2	Versión

1	Denominação de venda
2	Versão

1	Verkoopbenaming
2	Versie

1	Försäljningsbeteckning
2	Version

1	Myyntinimike
2	Versio

1	Наименование продажи
2	Модель

1	Όνομασία πώλησης
2	Έκδοση

1	Salgsbetegnelse
2	Version

1	Salgsbetegnelse
2	Utgave

1	Nazwa handlowa
2	Wersja

1	Prodejní název
2	Verze

1	Predajný názov
2	Verzia

1	Értékesítési elnevezés
2	Változat

1	Prodajni naziv
2	Različica

1	Denumire de vânzare
2	VARIANTĂ

1	Търговско наименование
2	Вариант

1	Satış bilgileri
2	Versiyon

1	Найменування продажу
2	Версія

1	فئة البيع
2	النوع

10.5 Numero di serie - Serial number - Numéro de matricule - Seriennummer - Número de serie - Número de série - Seriennummer - Seriennummer - Sarjanumero - Серийный номер - Αριθμός σειράς - Seriennummer - Seriennummer - Numer fabryczny - Výrobní číslo - Výrobné číslo - Sorozatszám - Serijska številka - Numărul de serie - Серийн номер - Seri numarası - Серійний номер - الرقم التسلسلي

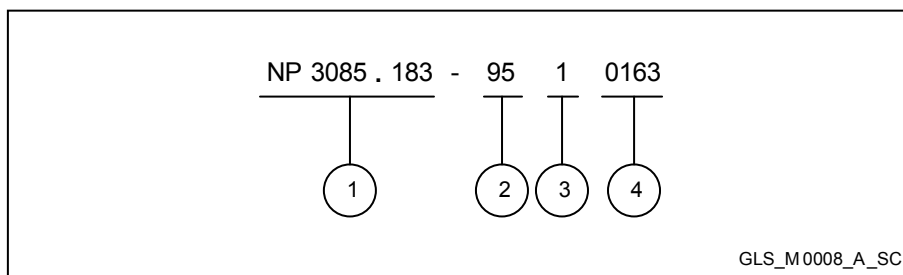

1	Codice prodotto
2	Anno di produzione
3	Ciclo di produzione
4	Numero progressivo

1	Product code
2	Manufacturing year
3	Manufacturing cycle
4	Running number

1	Référence produit
2	Année de fabrication
3	Cycle de production
4	Numéro progressif

1	Produktcode
2	Produktionsjahr
3	Produktionszyklus
4	Laufende Nummer

1	Código del producto
2	Año de producción
3	Ciclo de producción
4	Número progresivo

1	Código do produto
2	Ano de fabrico
3	Ciclo de fabrico
4	Número progressivo

1	Productcode
2	Productiejaar
3	Productiecyclus
4	Volgnummer

1	Produktkod
2	Tillverkningsår
3	Tillverkningscykel
4	Löpnummer

1	Laitteen koodi
2	Valmistusvuosi
3	Tuotantojakso
4	Kasvava numero

1	Код продукта
2	Год производства
3	Цикл производства
4	Порядковый номер

1	Κωδικός προϊόντος
2	Έτος παραγωγής
3	Κύκλος παραγωγής
4	Προοδευτικός αριθμός

1	Kode for apparat
2	Produktionsår
3	Produktionscyklus
4	Løbenummer

1	Apparatkode
2	Produksjonsår
3	Produksjonssyklus
4	Løpenummer

1	Kod produktu
2	Rok produkcji
3	Cykl produkcji
4	Numer progresywny

1	Kód výrobku
2	Rok výroby
3	Výrobní cyklus
4	Vzestupné číslo

1	Kód výrobku
2	Rok výroby
3	Výrobný cyklus
4	Vzostupné číslo

1	Termék kódszám
2	Gyártási év
3	Gyártási ciklus
4	Sorozatszám

1	Koda izdelka
2	Leto izdelave
3	Serija izdelave
4	Zaporedna številka

1	Cod produs
2	An de fabricație
3	Ciclu de producție
4	Număr de ordine

1	Код на изделието
2	Година на производство
3	Производствен цикъл
4	Прогресивен номер

1	Ürün kodu
2	İmalat yılı
3	Üretim dönemi
4	Seri numarası

1	Код виробу
2	Рік виробництва
3	Виробничий цикл
4	Прогресивний номер

1	كود المنتج
2	سنة التصنيع
3	دورة التصنيع
4	رقم التسلسل

10.6

Abbinamento pompe e dimensioni massime dei corpi solidi - pump combination and maximum size of solid substances - Association pompes et dimensions maximums des corps solides- Pumpenankupplung und maximale Abmessungen der Feststoffe - Acoplamiento bombas y dimensiones máximas de los cuerpos sólidos - Associação das bombas e dimensões máximas dos corpos sólidos - Combinatie pompen en maximum afmetingen van de vaste delen - Pumpanslutning och de fasta partiklarnas max. tillåtna mått - Pumppujen kytkentä ja kiinteiden hiukkasten maksimimitat - Сочетание насосов и максимальные размеры твердых частиц - Συνδυασμός αντλιών και μέγιστες διαστάσεις των στερεών σωμάτων - Sammenkobling mellem pumper og maks. størrelse for faste partikler - Sammenkopling mellom pumper og maks. mål for faste partikler - Zestawienie pomp i maksymalnych wymiarów ciał stałych - Použití čerpadel a maximální rozměry pevných těles - Použitie čerpadel a maximálne rozmery pevných telies - Szivattyú társítás és a szilárd testek maximális méretei - Združljivost črpalk in največje dimenzije trdnih delcev - Combinarea pompelor și dimensiunile maxime ale corpurilor solide - Съвместимост на модели помпи и максимални размери на твърдите тела - Pompa kombinasyonu ve katı cisimlerin maksimum ebadı - اقتران المضخات وأقصى أحجام للأجسام الصلبة -

	[mm]
GLS 50-15-251-S	48
GLS 50-15-251-P	
GLS 50-16-253-S	
GLS 50-16-253-P	
GLS 50-20-253-S	
GLS 50-20-253-P	
GLS 50-24-253-S	
GLS 50-24-253-P	
GLS 65-15-251	
GLS 65-15-251	
GLS 65-16-253	
GLS 65-20-253	
GLS 65-24-253	
GLS 65-32-253	
GLS 65-42-253	
GLS 80-32-253	
GLS 80-42-253	
GLS 80-59-253	
GLS 80-74-253	
GLS 100-24-453	39
GLS 100-31-453	38
GLS 100-45-453	
GLS 100-59-453	

	[mm]
GLV 50-12-251-S	48
GLV 50-12-251-P	
GLV 50-15-251-S	
GLV 50-15-251-P	
GLV 50-16-253-S	
GLV 50-16-253-P	
GLV 50-20-253-S	
GLV 50-20-253-P	
GLV 50-24-253-S	
GLV 50-24-253-P	
GLV 65-15-251	
GLV 65-16-253	
GLV 65-20-253	
GLV 65-24-253	
GLV 65-32-253	
GLV 65-42-253	
GLV 80-32-253	
GLV 80-42-253	80
GLV 80-59-253	
GLV 80-74-253	100
GLV 100-24-453	
GLV 100-31-453	
GLV 100-45-453	
GLV 100-59-453	

GLS_M0020_A_OT

- 10.7** Posizione livelli del liquido - liquid level position - Position niveaux du liquide- Position Füllstand des Fördermediums - Posición de los niveles del líquido - Posição níveis do líquido - Positie van de vloeistofniveaus - Væskenivåer - Nestetasot- liquid level position - Положение уровней жидкости - Θέση σταθμών του υγρού - Væskeniveauer - Væskenivåer - Pozycja poziomów cieczy - Povolené a nepovolené hladiny kapaliny - Povolené a nepovolené hladiny kvarpaliny - A folyadék szintjeinek állása - Položaji nivojev tekočine - Poziția nivelurilor de lichid - Положение на нивото на течността - Sivi seviyelerinin konumu - Положення рівнів рідини - مواضع مستويات السائل

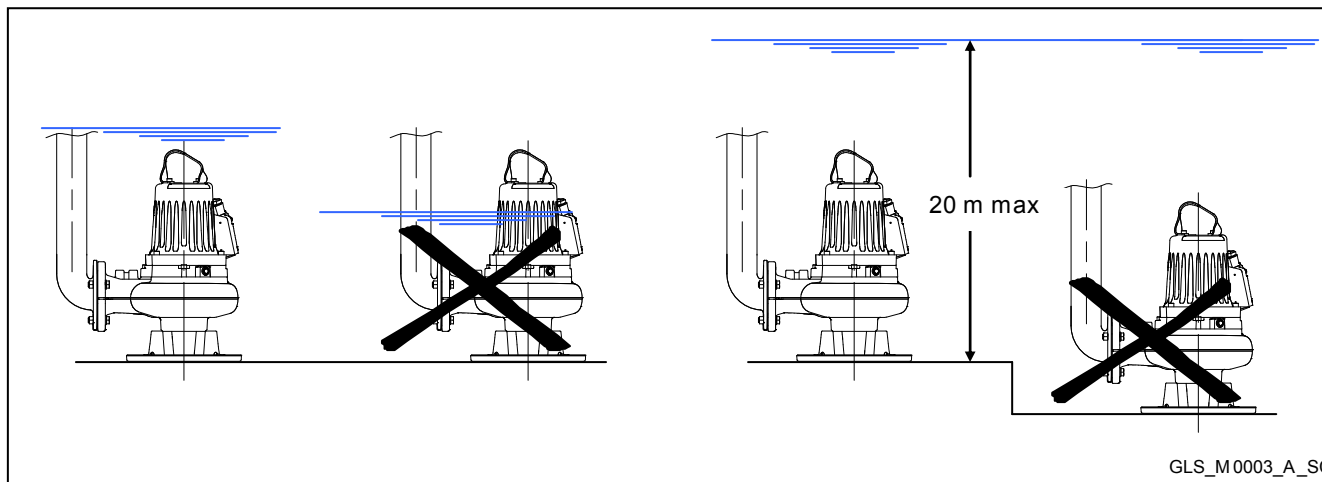

GLS_M0003_A_SC

- 10.8** Esempi di installazione - installation examples - Exemples d'installation - Installationsbeispiele - Ejemplos de instalación - Exemplos de instalação - Installatievoorbeelden - Exempel på installation - Asennusesimerkkejä - Примеры монтажа - Παραδείγματα εγκατάστασης - Installationsexempler - Installasjonsexempler - Przykłady montażu - Příklady montáže - Příklady montáže - Telepítési példák - Primeri montaže - Exemple de instalare - Видове инсталация - Tesisat örnekleri - Приклади монтажу - أمثلة التركيب

- 10.8.1** Con dispositivo di discesa (installazione fissa) - with lowering device (fixed installation) - Avec dispositif de calage (installation fixe) - Mit Senkvorrichtung (feste Installation) - Con dispositivo de descenso (instalación fija) - Com dispositivo de descida (instalação fixa) - Met neerlaatsysteem (vaste installatie) - Med nedsänkingsanordning (fast installation) - Laskulaitteella (kiinteä järjestelmä) - С устройством спуска (фиксированная установка) - Με διάταξη καθόδου (εγκατάσταση σταθερή) - Med sænkeudstyr (permanent installation) - Med senkeutstyr (permanent installasjon) - Z urządzeniem opuszczającym (montaż stały) - S klesajícím zařízením (pevná montáž) - S klesajúcim zariadením (pevná montáž) - Leeresztő egységgel (rögzített telepítés) - Z napravo za spuščanje (stalna montaža) - Cu dispozitiv de coborâre (instalare fixă) - С устройство за потапяне (неподвижна инсталация) - İndirme cihazı ile (sabit tesisat) - Із пристроєм спуску (фіксована установка) - بمعدات إنزال (تركيب ثابت)

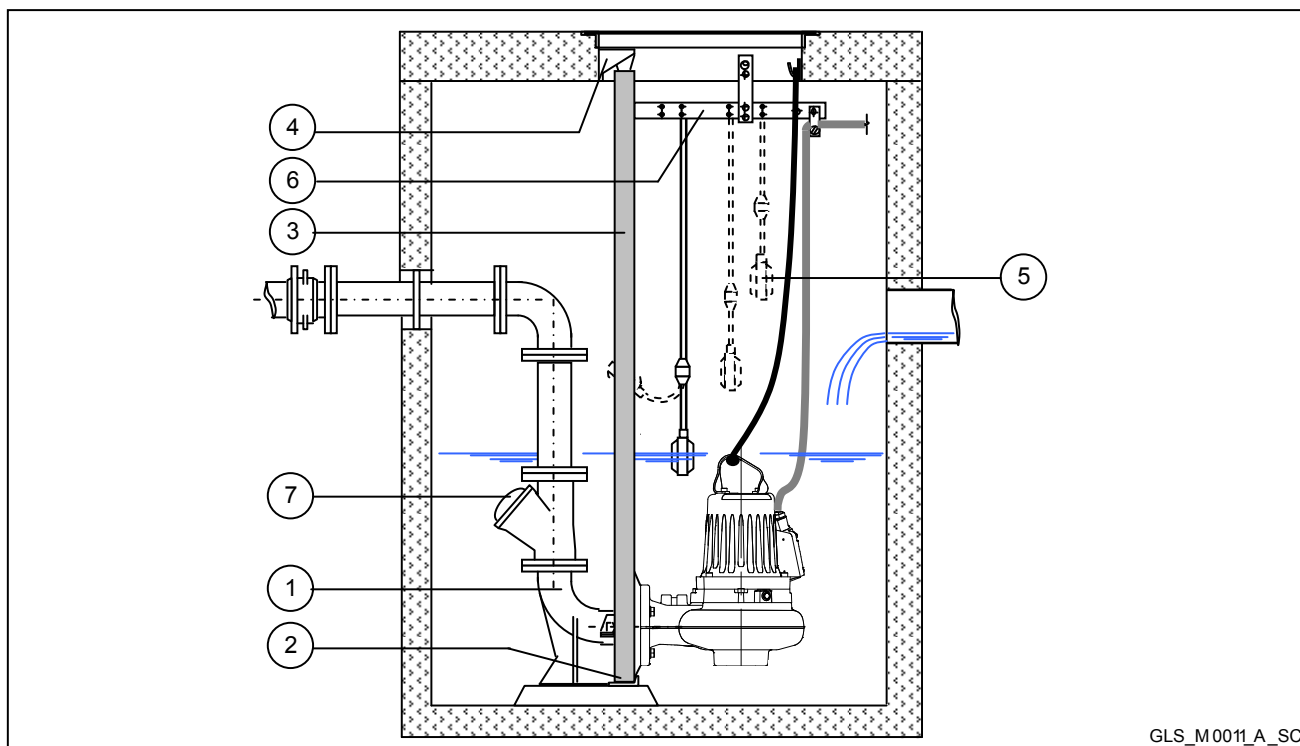

GLS_M0011_A_SC

1	Piede di appoggio e raccordo di accoppiamento con guarnizione in gomma
2	Le sedi inferiori per i tubi guida (talvolta possono essere integrate nel piede di appoggio)
3	Due tubi guida (talvolta può essere uno)
4	Una staffa superiore per i tubi guida, da fissare sull'orlo dell'apertura del pozzo
5	Galleggianti per l'avvio, l'arresto e l'allarme
6	Una staffa di supporto per i cavi del motore e dei galleggianti
7	Altri accessori, ad es. valvola a palla di non ritorno, saracinesca, flangie, ...

1	Pied d'assise et raccord d'accouplement avec joint en caoutchouc
2	Logements inférieurs pour les tubes de guidage (peuvent être intégrés parfois dans le pied d'assise)
3	Deux tubes de guidage (parfois un seul)
4	Patte supérieure pour les tubes de guidage, à fixer sur le bord de l'ouverture du forage
5	Flotteurs pour le démarrage, l'arrêt et l'alarme
6	Patte de support pour les câbles du moteur et des flotteurs
7	D'autres accessoires, par ex. clapet antiretour à boule, vanne, brides, ...

1	Pie de apoyo y empalme de acoplamiento con junta de goma
2	Los alojamientos inferiores para los tubos de guía (a veces pueden estar integrados en el pie de apoyo)
3	Dos tubos de guía (a veces puede ser uno)
4	Un estribo superior para los tubos de guía, que se debe fijar en el borde de la abertura del pozo
5	Interruptores de flotador para el arranque, la parada y la alarma
6	Un estribo de soporte para los cables del motor y de los interruptores de flotador
7	Otros accesorios, por ej. válvula de bola de retención, compuerta, bridas, ...

1	Steunvoet en verbindingsstuk met rubber dichting
2	Onderste zittingen voor de geleidebuizen (kunnen soms geïntegreerd zijn in de steunvoet)
3	Twee geleidebuizen (kan er soms één zijn)
4	Een bovenste beugel voor de geleidebuizen, te bevestigen aan de rand van de opening van de put
5	Vlotterschakelaars voor starten, stoppen en alarm
6	Een steunbeugel voor de kabels van de motor en de vlotterschakelaars
7	Andere accessoires, bijv. kogelbalkeerklep, afsluiter, flenzen enz.

1	Tukijalka ja kumitiivisteellä varustettu liitos
2	Ohjausputkien sisäistukat (joskus sisältyvät tukijalkaan)
3	Kaksi ohjausputkea (joskus yksi)
4	Ohjausputkien yläkannatin, joka kiinnitetään kaivon aukon reunaan
5	Käynnistys-, pysäytys- ja hälytysuimurit
6	Moottorien kaapelien ja uimurien tukikannatin
7	Muut varusteet esim. takaiskupalloventtiili, luisti, laipat jne.

1	Stand and coupling with rubber gasket
2	Lower seats for the guide tubes (on some models they may be incorporated in the stand)
3	Two guide tubes (or one, on some models)
4	One upper bracket for the guide tubes, to be secured to the well's mouth
5	Start, stop and alarm floats
6	A support bracket for the motor and float cables
7	Other accessories, e.g. non-return ball valve, gate valve, flanges, etc.

1	Stützfuß und Kupplungsanschluss mit Gummidichtung
2	Die unteren Aufnahmen für die Führungstohre (diese können auch im Stützfuß integriert sein)
3	Zwei Führungsrohre (manchmal auch nur ein einziges)
4	Ein oberer Bügel für die Führungsrohre, der am Rand der Brunnenöffnung befestigt werden muss
5	Schwimmerschalter für Start, Stopp und Alarm
6	Ein Stützbügel für die Kabel des Motors und der Schwimmerschalter
7	Anderei Zubehör, wie z.B. Kugelrückschlagventil, Schieber, Flansche, ...

1	Pé de assentamento e adaptador de acoplamento com guarnição de borracha
2	Sedes inferiores para os tubos guias (às vezes podem ser integradas no pé de assentamento)
3	Dois tubos guia (às vezes pode ser um)
4	Um estribo superior para os tubos guia a fixar na borda da abertura do furo
5	Flutuadores para o arranque, a paragem e o alarme
6	Um estribo de suporte para os cabos do motor e dos flutuadores
7	Outros acessórios, por ex. válvula de esfera anti-retorno, comporta, flanges,...

1	Stödfot och anslutningskoppling med gummipackning
2	Nedre säten för styrrören (kan ibland vara inbyggda i stödfoten)
3	Två styrrör (ibland endast ett)
4	En övre bygel för styrrören, som ska fästas i kanten på brunnsöppningen
5	Flottörer för start, stopp och larm
6	En stödbygel för motorns och flottörernas kablar
7	Övriga tillbehör som t.ex. backventil med kula, spjäll, flänsar o.s.v.

1	Опорная ножка и соединительный патрубок с резиновой прокладкой
2	Нижние гнезда для направляющих труб (иногда они могут быть встроены в опорную ножку)
3	Две направляющих трубы (иногда может быть одна)
4	Верхняя скоба для направляющих труб, прикрепляемая на край отверстия колодца
5	Поплавки для пуска, останова и тревоги
6	Опорная скоба кабелей двигателя и поплавкой
7	Прочие принадлежности, например, обратный шаровой клапан, дроссельная заслонка, фланцы, ...

1	Πόδι απόθεσης και ρακόρ σύζευξης με λαστιχένια τιμούχα
2	Οι κάτω έδρες για τους οδηγητικούς σωλήνες (μερικές φορές μπορούν να ενσωματώνονται στο πόδι απόθεσης)
3	Δύο οδηγητικοί σωλήνες (μερικές φορές μπορεί να είναι ένας)
4	Ένα επάνω πλαίσιο για τους οδηγητικούς σωλήνες, προς στερέωσης στο χέλιος του ανοίγματος του πηγαδιού
5	Πλωτήρες για την εκκίνηση, την ακινητοποίηση και το συναγερμό
6	Ένα πλαίσιο στήριξης για τα καλώδια του κινητήρα και των πλωτήρων
7	Άλλα αξεσουάρ, π.χ. βαλβίδα τύπου μπάλας ανεπίστροφη, με άνοιγμα, με φλάντζες, ...

1	Støttefod og kopling for sammenkopling med gummipakning
2	Nederste åpninger for styrerør (som i noen tilfeller er innebygget i støttefoten)
3	To styrerør (i noen tilfeller kun ett)
4	En toppmontert konsoll for styrerørene (som skal festes til kanten på brønnåpningen)
5	Flottører for start, stopp og alarm
6	En støttekonsoll for motorens og flottørenes kabler
7	Annet tilbehør som f.eks. tilbakeslagsventiler med kule, spjeld, flenser, osv.

1	Opěrná patka a spojovací část s gumovým těsněním
2	Spodní úchyty pro vodící trubky (někdy mohou být součástí opěrných patek)
3	Dvě vodící trubky (někdy může být pouze jedna)
4	Horní držák na vodící trubky, k upevnění na okraj otvoru jámy
5	Plováky pro spuštění, zastavení a alarm
6	Držák na kabely motoru a plováků
7	Další příslušenství, např. zpětný kulový ventil, škrtící ventil, příruby, atd.

1	Tartóláb és csatlakozó csőidom gumi tömítéssel.
2	Alsó foglalatok a csővezetékeknek (előfordulhat, hogy a tartólábba van építve)
3	Két csővezeték (előfordulhat, hogy egy van belőle)
4	Egy felső kengyel a csővezetékeknek, melyet a kút nyílásának szélére kell rögzíteni
5	Úszók az indításhoz, leállításhoz és riasztáshoz
6	Egy tartókengyel a motor és az úszók vezetékeihez
7	Más tartozékok, például visszacsapó gömbszelep, tolózár, karimák,

1	Picior de sprijin și racord cu garnitură din cauciuc
2	Locașuri inferioare pentru tuburi de ghidaj (uneori pot fi integrate în piciorul de sprijin)
3	Două tuburi de ghidaj (uneori poate fi unul)
4	O bridă superioară pentru tuburile de ghidaj, de fixat pe marginea gurii puțului
5	Plutitoare pentru pornire, oprire și alarmare
6	O consolă de suport pentru cablurile motorului și ale plutitoarelor
7	Alte accesorii, de exemplu, supapă de sens cu bilă, clapetă, flanșe, etc.

1	Støttefod og kobling til sammenkobling med pakning af gummi
2	Nederste sæder til styrerørene (er i nogle tilfælde indbygget i støttefoden)
3	To styrerør (i nogle tilfælde kun et)
4	En topmonteret konsol til styrerørene (skal fastgøres på kanten af brøndåbningen)
5	Flydere for start, afbrydelse og alarm
6	En støttekonsol til motorens og flydernes kabler
7	Andet tilbehør (eksempelvis kugleventil (bakventil), spjæld, flanger osv.)

1	Nóżka oparcia i przyłącze z gumowym uszczelnieniem
2	Dolne oprawy dla rur prowadzących (czasami mogą być zintegrowane z nóżką oparcia)
3	Dwie rury prowadzące (czasami może być jedna)
4	Górny wspornik do rur prowadzących, do zamocowania na obrzeżu otworu studni
5	Pływaki do rozruchu, zatrzymania i alarmu
6	Wspornik do kabli silnika i pływaków
7	Inne akcesoria, np. zawór kulowy zwrotny, zasuwa, kołnierze, ...

1	Oporná noha a spojovacia časť s gumovým tesnením
2	Spodné úchyty pre vodiace potrubia (niekedy môžu byť súčasťou oporných nôh)
3	Dve vodiace potrubia (niekedy môže byť len jedno)
4	Horný držiak na vodiace potrubia, k upevnieniu na okraj otvoru jamy/studne
5	Plaváky na uvedenie do prevádzky, zastavenie a alarm
6	Držiak na káble motora a plaváku
7	Ďalšie príslušenstvo, ako napr. spätný guľový ventil, škrtiaci ventil, príruby, atď.

1	Nosilni podstavek in priključek za povezavo z gumijastim tesnilom
2	Spodnji sedeži za vodilne cevi (včasih so lahko vgrajeni v nosilni podstavek)
3	Dve vodilni cevi (včasih samo ena)
4	Zgornje streme za vodilne cevi, pritrdi se na rob odprtine jaška
5	Plovci za zagon, ustavitve in alarm
6	Nosilno streme za kable motorja in plovcev
7	Ostali pribor, na primer enosmerni krogelni ventil, zapora, prirobnice, ...

1	Опорна основа и съединително коляно с гумено уплътнение
2	Гнезда на опорните тръби (при някои модели са инкорпорирани в основата)
3	Две опорни тръби (при някои модели есамо една)
4	Фиксаторна скоба за закрепване на опорните тръби към ръба на изкопа
5	Поплавъци за пускане, спиране и аларма
6	Подпора за кабелите на мотора и поплавъците
7	Други принадлежности: обратен клапан със сфера, затваряща клапа, фланци и др.

1	Destek ayağı ve lastik contalı bağlama rakoru
2	Kılavuz borularının alt yuvaları (bazen destek ayağına entegre olabilir)
3	İki adet kılavuz borusu (bazen yalnız bir boru bulunabilir)
4	Kılavuz borularının kuyu açıklığı kenarına tespit edilecek üst desteği
5	Yol verme, durdurma ve alarm flatörleri
6	Motor ve flatör kablolarının destek elemanı
7	Örneğin geri dönüşsüz bilyeli valf, sürgülü vana, flanşlar, ... gibi aksesuarlar

1	Опорна ніжка і з'єднувальний патрубков з гумовою прокладкою.
2	Нижні гнізда для спрямовуючих труб (іноді вони можуть бути вбудовані в опорну ніжку).
3	Дві спрямовуючі труби (іноді може бути одна).
4	Верхня скоба для спрямовуючих труб, що кріпиться на краю отвору колодезя.
5	Поплавці для запуску, зупинки і тривоги (сигналізації).
6	Опорна скоба кабелів двигуна і поплавців.
7	Інше приладдя, наприклад, зворотний кульовий клапан, дросельна заслінка, фланці та ін.

1	حامل ارتكاز ووصلة اقتران بسدادات مطاطية
2	المراكز السفلى لأنابيب الدليل (تدمج في بعض الأحيان في حامل الارتكاز)
3	عدد 2 أنابيب الدليل (في بعض الأحيان أنبوبية واحدة)
4	ركاب أعلى لأنابيب الدليل، يتم تركيبه على حافة فتحة البئر
5	عوامات لبدء التشغيل، والإيقاف، والإنذار
6	ركاب دعم لكابلات المحرك والعوامات
7	كماليات أخرى، مثل صمام كرة عدم رجوع، بوابة، حافات أنابيب

ATTENZIONE

Garantite un raffreddamento sufficiente al motore. Regolate il galleggiante in modo da non superare il numero massimo di avviamenti orari (→ sezione 3.1.5).

WARNING

Ensure adequate motor cooling. Adjust the float so as not to exceed the maximum number of starts per hour (→ section 3.1.5).

ATTENTION

Garantissez un refroidissement suffisant au moteur. Réglez le flotteur de manière à ne pas dépasser le nombre maximum de démarrages horaires (→ section 3.1.5).

ACHTUNG!

Für eine ausreichende Abkühlung des Motors sorgen. Den Schwimmerschalter so einstellen, dass nicht die maximale Anzahl von stündlichen Anläufen überschritten wird (→ Abschnitt 3.1.5).

ATENCIÓN

Garantizar una refrigeración suficiente al motor. Regular el interruptor de flotador para no superar el número máximo de arranques por hora (→ sección 3.1.5).

ATENÇÃO

Garantir um arrefecimento suficiente ao motor. Regular o flutuador de forma a não exceder o número máximo de arranques por hora (→ secção 3.1.5).

LET OP

Zorg voor voldoende koeling voor de motor. Regel de vlotter schakelaar zodanig dat het maximale aantal starts per uur niet overschreden wordt (→ par. 3.1.5).

VARNING!

Säkerställ en korrekt motorkylning. Ställ in flottören så att max. tillåtet antal starter per timme inte överskrider (se avsnitt 3.1.5).

VAROITUS

Varmista moottorin riittävä jäähdytys. Säädä uimuri, niin ettei maksimikäynnistysmäärä tunnissa ylity (→ osa 3.1.5).

ВНИМАНИЕ

Необходимо гарантировать хорошее охлаждение двигателя. Отрегулировать поплавков так, чтобы не превышать максимальное количество часовых запусков (→ раздел 3.1.5).

ΠΡΟΣΟΧΗ

Εξασφαλίστε μια επαρκή ψύξη στον κινητήρα. Ρυθμίστε τον πλωτήρα έτσι ώστε να μην ξεπερνάει το μέγιστο αριθμό ωριαίων εκκινήσεων (→ ενότητα 3.1.5).

ADVARSEL

Sørg for tilstrækkelig afkøling af motoren. Indstil flyderen således, at maks. antallet af starter pr. time ikke overskrider (→ afsnit 3.1.5).

ADVARSEL

Sørg for en tilstrekkelig avkjøling av motoren. Innstill flottøren slik at maks. antall oppstarer pr. time ikke overstiges (se avsnitt 3.1.5).

UWAGA

Zapewnić odpowiednie chłodzenie silnika. Wyregulować pływaki w taki sposób, aby nie przekraczać maksymalnej liczby rozruchów godzinowych (→ podpunkt 3.1.5).

POZOR

Zajistěte dostatečné chlazení motoru. Nastavte plovák tak, aby nemohlo dojít k překročení maximálního počtu spuštění za hodinu (→ část 3.1.5).

UPOZORNENIE

Zaistite dostatočné chladenie motora. Nastavte plavák tak, aby nemohlo dôjsť k prekročeniu maximálneho počtu zapnutí za hodinu (→ časť 3.1.5).

FIGYELEM

Biztosítson megfelelő hűlést a motornak. Úgy állítsa be az úszót, hogy ne lépje túl az óránkénti maximális indítások számát (→ 3.1.5 szakasz).

POZOR

Zagotovite zadostno hlajenje motorja. Plovec nastavite tako, da se ne preseže največje število zagonov na uro (→ poglavje 3.1.5).

ATENȚIE

Asigurați o răcire corespunzătoare a motorului. Reglați plutitorul astfel încât să nu se depășească numărul maxim de porniri pe oră (→ secțiunea 3.1.5).

ВНИМАНИЕ

Осигурете достатъчно охлаждане на мотора. Регулирайте поплавъка, така че да не превишава максималния брой работни цикли на час (→ виж т. 3.1.5).

ДИККАТ!

Motorun yeterli soğuması sağlanmalıdır. Flatör saatte maksimum pompa şalt sayısı aşılmayacak şekilde ayarlanmalıdır (bkz. → paragraf 3.1.5).

УВАГА!

Забезпечте належне охолодження двигуна. Відрегулюйте поплавець так, щоб не перевищувати максимальну кількість запусків за годину (→ розділ 3.1.5).

قم بتوفير التبريد الكاف للمحرك. اضبط العوامات بحيث لا تتجاوز عدد ساعات التشغيل المسموح بها (الفقرة 5.1.3).

انتبه

10.8.2 Con piede di appoggio - with stand - Avec pied d'assise - Mit Stützfuß - Con pie de apoyo - Com pé de assentamento - Met steunvoet - Med stödfot - Tukijalalla - С опорной ножкой - Με πόδι στήριξης - Med støttestofod - Med støttestofot - Z nóżką oparcia - S opěrnou patkou - S opornou nohou - Tartólábbal - Z nosilním podstavkom - Cu picior de sprijin - С опорен крак - Destek ayağı ile - З опорною ніжною - المزودة بحامل ارتكاز

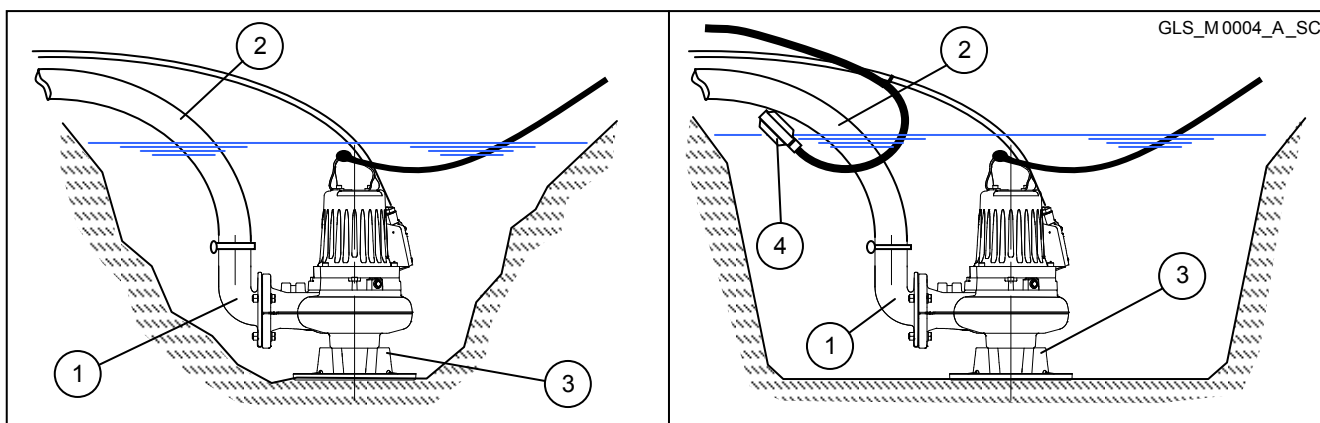

1	Raccordo
2	Tubo flessibile (installazione trasportabile) o semirigido (installazione semi-fissa)
3	Piede di appoggio
4	Galleggiante (installazione semi-fissa)

1	Union
2	Flexible pipe (movable installation) or semi-rigid pipe (semi-fixed installation)
3	Stand
4	Float (semi-fixed installation)

1	Raccord
2	Tuyau flexible (installation transportable) ou semi-rigide (installation semi-fixe)
3	Pied d'assise
4	Flotteur (installation semi-fixe)

1	Anschluss
2	Flexibler (tragbare Installation) oder halbsteifer Schlauch (halbstationäre Installation)
3	Stützfuß
4	Schwimmerschalter (halbstationäre Installation)

1	Empalme
2	Tubo flexible (instalación transportable) o semirrigido (instalación semifija)
3	Pie de apoyo
4	Interruptor de flotador (instalación semifija)

1	União
2	Tubo flexível (instalação transportável) ou semi-rígido (instalação semi-fixa)
3	Pé de assentamento
4	Flutuador (instalação semi-fixa)

1	Verbinding
2	Buigzame pijp (meeneembare installatie) of half onbuigzame pijp
3	Steunvoet
4	Vlotterschakelaar (halfvaste installatie)

1	Koppling
2	Slang (flyttbar installation) eller halvflexibelt rör (delvis fast installation)
3	Stödfot
4	Flottör (delvis fast installation)

1	Liitos
2	Letku (liikutettava järjestelmä) tai puolijäykkä putki (puolikiinteä järjestelmä)
3	Tukijalka
4	Uimuri (puolikiinteä järjestelmä)

1	Ρακόρ
2	Εύκαμπτος σωλήνας (εγκατάσταση μετακινήσιμη) ή ημισκληρός (εγκατάσταση ημι-σταθερή)
3	Πόδι απόθεσης
4	Πλωτήρας (εγκατάσταση ημι-σταθερή)

1	Kopling
2	Slange (transportabel installasjon) eller fleksirør (delvis transportabel installasjon)
3	Støttefot
4	Flottør (delvis transportabel installasjon)

1	Spojovací kus
2	Flexibilní (dočasná montáž) nebo polopevná (polopevná montáž) trubka
3	Opěrná patka
4	Plovák (polopevná montáž)

1	Csatlakozódóm
2	Flexibilis cső (szállítható telepítés) vagy félmerev cső (részlegesen rögzített telepítés)
3	Tartóláb
4	Úszó (részlegesen rögzített telepítés)

1	Racord
2	Tub flexibil (instalare mobilă) sau semirigid (instalare semifixă)
3	Picior de sprijin
4	Plutitor (instalare semifixă)

1	Rakor
2	Esnek boru (taşınabilir tesisat) veya yarı esnemez boru (yarı sabit tesisat)
3	Destek ayağı
4	Flatör (yarı sabit tesisat)

1	وصلة
2	أنبوبية مرنة (للتركيب المتنقل) أو شبه صلبة (للتركيب النصف ثابت)
3	حامل ارتكاز
4	عوامة (للتركيب النصف ثابت)

1	Патрубок
2	Шланг (переносная установка) или полужесткая труба (полуфиксированная установка)
3	Опорная ножка
4	Поплавок (полуфиксированная установка)

1	Kobling
2	Slange (transportabel installation) eller flex-rør (delvist transportabel installation)
3	Støttefod
4	Flyder (delvist transportabel installation)

1	Łącznik
2	Przewód giętki (montaż transportowany) lub półsztywny (montaż pół-stały)
3	Nóżka oparcia
4	Pływak (montaż pół-stały)

1	Spojovací kus
2	Flexibilná (dočasná montáž) alebo polopevná (polopevná montáž) rúrka
3	Oporná noha
4	Plavák (polopevná montáž)

1	Priključek
2	Gibka cev (prenosna montaža) ali deloma toga (delno stalna montaža)
3	Nosilni podstavek
4	Plovec (delno stalna montaža)

1	Съединително коляно
2	Гъвкава тръба (подвижна инсталация) или полугъвкава (полу фиксирана инсталация)
3	Опорен крак
4	Поплавок (полу фиксирана инсталация)

1	Патрубок
2	Шланг (переносна установка) або напівжорстка труба (напівфіксована установка)
3	Опорна ніжка
4	Поплавець (напівфіксована установка)

Alcune elettropompe sono dotate di piede di appoggio ricavato sul corpo pompa. Negli altri casi chiedete il relativo accessorio.

ATTENZIONE

Garantite un raffreddamento sufficiente al motore. Ponete il cavo del motore lontano dall'elettropompa in modo da non essere aspirato. Controllate che durante il pompaggio l'elettropompa non affondi nel fango. Versione per installazione semi-fissa: Regolate il galleggiante in modo da non superare il numero massimo di avviamenti orari (→ sezione 3.1.5).

While on some models the stand is an integral part of the pump body, in other cases it must be requested separately.

WARNING

Ensure adequate motor cooling. Position the motor cable away from the electric pump to prevent its being sucked into the intake. Make sure the electric pump does not sink in the mud during operation. Version for semi-fixed installation: adjust the float so as not to exceed the maximum number of starts per hour (→ section 3.1.5).

Certaines électropompes sont munies de pied d'assise ménagé sur le corps de pompe. Dans les autres cas, demandez l'accessoire correspondant.

ATTENTION

Garantissez un refroidissement suffisant au moteur. Placez le câble du moteur loin de l'électropompe de manière à ne pas être aspiré. Contrôlez que durant le pompage l'électropompe ne s'enfonce pas dans la boue. Version pour installation semi-fixe : Réglez le flotteur de manière à ne pas dépasser le nombre maximum de démarrages horaires (→ section 3.1.5).

Einige Motorpumpen sind mit am Pumpenkörper integrierten Stützfuß ausgestattet. In den anderen Fällen fordern Sie das entsprechende Zubehör an.

ACHTUNG!

Für eine ausreichende Abkühlung des Motors sorgen. Das Kabel des Motors weit ab von der Motorpumpe verlegen, damit es nicht angesaugt werden kann. Kontrollieren, dass die Motorpumpe während des Pumpvorgangs nicht im Schlamm versinkt.
Version für halbstationäre Installation: Den Schwimmerschalter so einstellen, dass nicht die maximale Anzahl von stündlichen Anläufen überschritten wird (→ Abschnitt 3.1.5).

Algunas electrobombas están dotadas de pie de apoyo obtenido en la caja bomba. En los otros casos se debe pedir el accesorio correspondiente.

ATENCIÓN

Garantizar una refrigeración suficiente al motor. Situar el cable del motor lejos de la electrobomba para evitar que sea aspirado. Controlar que la electrobomba no se hunda en el barro durante el bombeo.
Versión para instalación semifija: regular el interruptor de flotador para no superar el número máximo de arranques por hora (→ sección 3.1.5).

Algumas electrobombas estão equipadas com pé de assentamento criado no corpo da bomba. Nos outros casos solicitar o acessório relativo.

ATENÇÃO

Garantir um arrefecimento suficiente ao motor. Colocar o cabo do motor longe da electrobomba de modo a que não seja aspirado. Controlar que durante a bombagem a electrobomba não afunde na lama.
Versão para instalação semi-fixa: regular o flutuador de forma a não exceder o número máximo de arranques por hora (→ secção 3.1.5).

Sommige elektropompen zijn voorzien van een steunvoet die op het pomplichaam aangebracht is. Vraag in de andere gevallen om het betreffende accessoire.

LET OP

Zorg voor voldoende koeling voor de motor. Leg de kabel van de motor uit de buurt van de elektropomp zodat deze niet aangezogen kan worden. Controleer of de elektropomp tijdens het pompen niet in de modder zakt.
Model voor halfvaste installatie: Regel de vlotterchakelaar zodanig dat het maximale aantal starts per uur niet overschreden wordt (→ par. 3.1.5).

Vissa elpumpar är utrustade med stödfot som utgör en del av pumphuset. På andra elpumpar får du beställa stödbenet som tillval.

VARNING!

Säkerställ en korrekt motorkylning. Lägg motorkabeln på behörigt avstånd från elpumpen så att den inte riskerar att sugas in. Kontrollera att elpumpen inte sjunker ned i leran under pumpningen.
Version för delvis fast installation: Ställ in flottören så att max. tillåtet antal starter per timme inte överskrider (se avsnitt 3.1.5).

Joissakin sähköpumpuissa on pumpun runkoon asennettu tukijalka. Pyydä muussa tapauksessa asianmukainen lisävaruste.

VAROITUS

Varmista moottorin riittävä jäähdytys. Sijoita moottorin kaapeli etäälle sähköpumpusta, ettei pumppu ime sitä sisään. Varmista, ettei sähköpumppu uppoa mutaan pumppauksen aikana.
Versio puoliikiinteälle järjestelmälle: säädä uimuri, niin ettei maksimikäynnistysmäärä tunnissa ylity (→ osa 3.1.5).

Некоторые электронасосы имеют опорную ножку, сделанную в корпусе насоса. В других случаях необходимо заказывать специальную принадлежность.

ВНИМАНИЕ

Необходимо гарантировать хорошее охлаждение двигателя. Поместить кабель двигателя вдали от электронасоса, чтобы его нельзя было засосать. Проверить, чтобы во время перекачивания электронасос не тонул в грязи.
Модель для полуфиксированной установки: отрегулировать поплавков так, чтобы не превышать максимальное количество часовых запусков (→ раздел 3.1.5).

Ορισμένες ηλεκτρικές αντλίες διαθέτουν πόδι απόθεσης διαμορφωμένο στο σώμα αντλίας. Στις άλλες περιπτώσεις ζητήστε το σχετικό αξεσουάρ.

ΠΡΟΣΟΧΗ

Εξασφαλίστε μια επαρκή ψύξη στον κινητήρα. Βάλτε το καλώδιο του κινητήρα μακριά από την ηλεκτρική αντλία έτσι ώστε να μην απορροφηθεί. Ελέγξτε αν κατά την άντληση η ηλεκτρική αντλία βυθίζεται στη λάσπη.
Έκδοση για την ημι-σταθερή εγκατάσταση: Ρυθμίστε τον πλωτήρα έτσι ώστε να μην ξεπερνάει το μέγιστο αριθμό ωριαίων εκκινήσεων (→ ενότητα 3.1.5).

Visse elektropumper er udstyret med støtiefod på pumpehuset. I de øvrige tilfælde er det nødvendigt at bestille støtiefoden som tilbehør.

ADVARSEL

Sørg for tilstrækkelig afkøling af motoren. Anbring motorens kabel i god afstand fra elektropumpen således, at det ikke suges ind. Kontrollér, at elektropumpen ikke synker ned i dyndet i forbindelse med pumpningen.
Version til delvist transportabel installation: Indstil flyderen således, at maks. antallet af starter pr. time ikke overskrider (→ afsnit 3.1.5).

Noen elektropumper er utstyrte med støttefot på pumpehuset. I andre tilfeller er det nødvendig å bestille støttefoten som tilbehør.

ADVARSEL

Sørg for en tilstrekkelig avkjøling av motoren. Legg motorkabelen langt unna elektropumpen slik at den ikke suges inn. Kontroller at elektropumpen ikke synker ned i gjørmene under pumpingen.

Utgave for delvis transportabel installasjon: Innstill flottøren slik at maks. antall oppstarer pr. time ikke overstiges (se avsnitt 3.1.5).

Niektóre elektropompy są wyposażone w nóżki oparcia wykonane w korpusie pompy. W innych przypadkach zwrócić się o dostarczenie właściwego komponentu.

UWAGA

Zapewnić odpowiednie chłodzenie silnika. Ułożyć kabel silnika z dala od elektropompy, aby nie został zassany. Sprawdzać czy podczas pompowania elektropompa nie zanurza się w błocie.

Wersja do montażu pół-stałego: wyregulować pływak w taki sposób, aby nie przekraczać maksymalnej liczby rozruchów godzinowych (→ podpunkt 3.1.5).

Některá elektročerpadla jsou osazena opěrnou patkou vytvořenou na těle čerpadla. V ostatních případech si příslušný komponent vyžádejte.

POZOR

Zajistěte dostatečné chlazení motoru. Umístěte kabel motoru dostatečně daleko od elektročerpadla, aby nedošlo k jeho nasátí. Zkontrolujte, jestli se během čerpání elektročerpadlo nepropadá do bahna.

Verze pro polopevnou montáž: Nastavte plovák tak, aby nemohlo dojít k překročení maximálního počtu spuštění za hodinu (→ část 3.1.5).

Niektoré elektrické čerpadlá sú vybavené opornou nohou vytvorenou na telese čerpadla. V ostatných prípadoch si príslušný komponent vyžadajte.

UPOZORNENIE

Zaistite dostatočné chladenie motora. Umiestnite kábel motora dostatočne ďaleko od elektrického čerpadla, aby nedošlo k jeho nasaniu. Skontrolujte, či elektrické čerpadlo sa počas odčerpávania neprepadá do bahna.

Verzia pre polopevnú montáž: Nastavte plavák tak, aby nemohlo dôjsť k prekročeniu maximálneho počtu zapnutí za hodinu (→ časť 3.1.5).

Néhány elektromos szivattyú a szivattyútesten kialakított tartólábbal rendelkezik. Ettől eltérő esetben kérje a vonatkozó tartozékot.

FIGYELEM

Biztosítson megfelelő hűlést a motornak. A motor vezetékeit az elektromos szivattyútól távol helyezze el, nehogy beszívásra kerüljön. Ellenőrizze, hogy a szivattyúzás alatt az elektromos szivattyú ne merüljön a sárba.

Változat a részlegesen rögzített telepítéshez: Úgy állítsa be az úszót, hogy ne lépje túl az óránkénti maximális indítások számát (→ 3.1.5 szakasz).

Nekatere električne črpalke so opremljene z nosilnim podstavkom na ohišju črpalke. V drugih primerih zahtevajte pripadajoči pribor.

POZOR

Zagotovite zadostno hlajenje motorja. Kabel motorja namestite stran od električne črpalke tako, da ga ne more vsesati. Preverite, da se med črpanjem električna črpalčka ne potopi v blato.

Različica za delno stalno montažo. Plovec nastavite tako, da se ne preseže največje število zagonov na uro (→ poglavje 3.1.5).

Unele electropompe sunt dotate cu picior de sprijin care face corp comun cu pompa. În celelalte cazuri solicitați accesoriul respectiv.

ATENȚIE

Asigurați o răcire corespunzătoare a motorului. Poziționați cablul motorului astfel încât să nu poată fi aspirat de pompă. Verificați ca pe durata pompării electropompa să nu se cufunde în noroi.

Varianta pentru instalare semifixă: reglați plutitorul astfel încât să nu se depășească numărul maxim de porniri pe oră (→ secțiunea 3.1.5).

При някои модели, опорният крак е част от тялото на помпата. В останалите случаи, приспособлението се поръчва.

ВНИМАНИЕ

Осигурете достатъчно охлаждане на мотора. Дръжте кабела на мотора далеч от помпата за да не бъде засмукан. Проверете дали по време на работа, помпата не потъва в калта.

Вариант на полу фиксирана инсталация: регулирайте поплавека, така че да не надвишава максималния брой работни цикли на час (→ виж т. 3.1.5).

Bazı elektrikli pompalar pompa gövdesinde bulunan destek ayağıyla donatılmıştır. Başka durumlarda ilgili aksesuarın teslimini talep edin.

DİKKAT!

Motorun yeterli soğumasını sağlayın. Motor kablosu elektrikli pompanın içine emilmemesi için pompadan uzak tutulmalıdır. Pompalama işlemi sırasında elektrikli pompanın çamura batmadığını kontrol edin.

Yarı sabit tesisat için tasarlanan versiyon. Flatör saatte maksimum pompa şalt sayısı aşılmayacak şekilde ayarlanmalıdır (bkz. → paragraf 3.1.5).

Корпуси деяких електронасосів обладнано опорною ніжною. В інших випадках необхідно замовляти спеціальне приладдя.

УВАГА!

Забезпечте належне охолодження двигуна. Розташуйте кабель двигуна подалі від електронасоса, щоб запобігти його засмоктанню. Перевірте, щоб під час перекачування електронасос не занурювався у бачно.

Модель для напівфіксованої установки: відрегулюйте поплавець так, щоб не перевищувати максимальну кількість запусків за годину (→ розділ 3.1.5).

بعض المضخات الكهربائية مزودة بحامل ارتكاز في جسم المضخة. في الحالات الأخرى، قم بطلب مكونات الكماليات المرادفة لذلك. قم بتوفير التبريد الكاف للمحرك. ضع كابل المحرك بعيداً عن المضخة الكهربائية بحيث ألا يتم شفطه. تأكد أنه خلال الضخ أن لا يتم غمر المضخة الكهربائية في الطين. لأنواع التركيب النصف ثابت: اضبط العوامات بحيث لا تتجاوز عدد ساعات التشغيل المسموح بها (الفقرة 5.1.3).

انتبه

10.9 Schemi collegamenti cavo di alimentazione - Power cable wiring diagrams - Schéma de connexion câble d'alimentation - Anschlusspläne Speisekabel - Esquemas de conexiones del cable de alimentación - Esquemas das ligações do cabo de alimentação - Aansluitschema's van de voedingskabel - Kopplingsscheman för elkabel - Sähkökaapelin liitäntäkaaviot - Схемы соединений кабеля питания - Σχέδια συνδέσεων καλωδίου τροφοδοσίας - Elskemaer for forsyningskabel - Koplingsskjemaer for nettkabel - Schematy połączeń kabla zasilającego - Schemata zapojeni napájecího kabelu - Schémý zapojenia napájacieho kábla - A tápvezeték csatlakozási ábrái - SHEME povezave napajalnega kabla - Schemele de conectare a cablului de alimentare - Схеми за свързване на захрнвация кабел - Besleme kablosunun bağlanti şemaları - Схеми з'єднання кабелю живлення - صور توصيلات كابل التغذية

10.9.1 Conessioni e sequenza fasi - Connections and phase sequence - Branchements et séquence des phases - Anschlüsse und Phasensequenz - Conexiones y secuencia de fases - Ligações e sequência das fases - Anslutningen en fasevolgorde - Anslutningar och sekvensfaser - Liittimet ja vaihejärjestys - Соединения и последовательность фаз - Συνδέσεις και συχρότητα φάσεων - Tilslutninger og fasesekvens - Tilkoplinger og fasesekvens - Połączenia i kolejność faz - Zapojení a sekvence fází - Zapojenia a sekvencia fáz - Csatlakozások és fázis sorrend - Povezava in zaporedje faz - Conexiuni și secvența fazelor - Свързки и последователност на фазите - Fazların bağlantisı ve sırası - З'єднання і послідовність фаз - وصلات وتسلسل المراحل

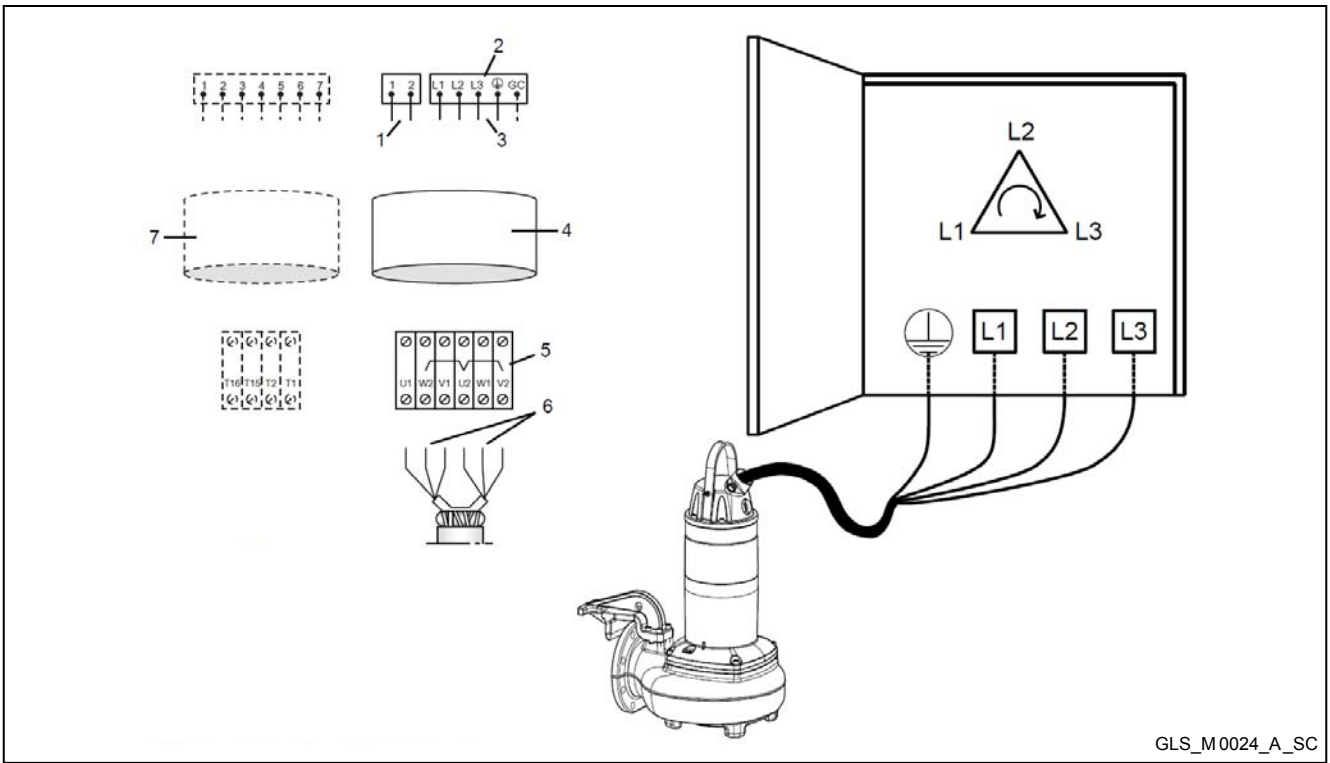

1	Conduttori sonda termica
2	Dispositivo di avviamento
3	Conduttori del cavo motore
4	Cavo motore
5	Morsettiera sulla pompa
6	Conduttori statore
7	Cavo sonda termica

1	Heat sensor leads
2	Starter
3	Motor cable leads
4	Motor cable
5	Terminal board on pump
6	Stator leads
7	Heat sensor cable

1	Conducteurs sonde thermique
2	Dispositif de démarrage
3	Conducteurs du câble moteur
4	Câble moteur
5	Bornier embarqué
6	Conducteurs stator
7	Câble sonde thermique

1	Leiter Temperaturfühler
2	Anlaufvorrichtung
3	Motor Kabelleiter
4	Motorkabel
5	Klemmenkasten an der Pumpe
6	Stator Leiter
7	Temperaturfühler Leiter

1	Conductores de la sonda térmica
2	Dispositivo de arranque
3	Conductores del cable motor
4	Cable del motor
5	Caja de bornes en la bomba
6	Conductores del estator
7	Cable de la sonda térmica

1	Geleiders thermische voeler
2	Startsysteem
3	Geleiders motorkabel
4	Motorkabel
5	Klemmenkast op pomp
6	Geleiders stator
7	Kabel thermische voeler

1	Lämpöanturin johtimet
2	Käynnistyslaite
3	Moottorin kaapelin johtimet
4	Moottorin sähkökaapeli
5	Pumpun liitinalusta
6	Staattorin johtimet
7	Lämpöanturin kaapeli

1	Αγωγοί θερμικού αισθητήρα
2	Διάταξη εκκίνησης
3	Αγωγοί του καλωδίου κινητήρα
4	Καλώδιο κινητήρα
5	Συστοιχία ακροδεκτών στην αντλία
6	Αγωγοί στάτορα
7	Καλώδιο θερμικού αισθητήρα

1	Ledere i varmesonde
2	Starter
3	Ledere i motorkabel
4	Motorkabel
5	Klemmebrett på pumpen
6	Ledere i stator
7	Varmesondens kabel

1	Vodiče teplotní sondy
2	Spouštěcí zařízení
3	Vodiče kabelu motoru
4	Kabel motoru
5	Svorkovnice na čerpadle
6	Vodiče statoru
7	Kabel teplotní sondy

1	Hőszonda vezetőék
2	Indító egység
3	A motorkábel vezetőékei
4	Motorkábel
5	Kapcsoló a szivattyún
6	Állórész vezetőékek
7	Hőszonda kábel

1	Conductoare senzor termic
2	Dispozitiv de pornire
3	Conductoare cablu motor
4	Cablu motor
5	Placă de borne pe pompă
6	Conductoare stator
7	Cablu senzor termic

1	Isi probunun iletkenleri
2	Yol verme tertibatı
3	Motor kablosunun iletkenleri
4	Motor kablosu
5	Pompadaki terminal kutusu
6	Stator iletkenleri
7	Isi probu kablosu

1	Condutores da sonda térmica
2	Dispositivo de arranque
3	Condutores do cabo motor
4	Cabo motor
5	Barra dos grampos na bomba
6	Condutores estator
7	Cabo sonda térmica

1	Ledare för värmegivare
2	Startanordning
3	Ledare motorkabel
4	Motorkabel
5	Kopplingsplint på pump
6	Statorledare
7	Värmegivarkabel

1	Проводники температурного зонда
2	Пусковое устройство
3	Проводники кабеля двигателя
4	Кабель двигателя
5	Клеммник на насосе
6	Проводники статора
7	Кабель температурного зонда

1	Ledere i termisk sonde
2	Starter
3	Ledere i motorens kabel
4	Motorens kabel
5	Klembræt på pumpe
6	Ledere i stator
7	Kabel i termisk sonde

1	Przewody sondy termicznej
2	Urządzenie uruchamiające
3	Przewody kabla silnika
4	Kabel silnika
5	Skrzynka zaciskowa na pompie
6	Przewody stojanu
7	Kabel sondy termicznej

1	Vodiče teplotnej sondy
2	Zariadenie na uvedenie do prevádzky
3	Vodiče kábla motora
4	Kábel motora
5	Svorkovnica na čerpadle
6	Vodiče statora
7	Kábel teplotnej sondy

1	Vodniki toplotnega tipala
2	Naprava za zagon
3	Vodniki kabla motorja
4	Kabel motorja
5	Sponke na črpalki
6	Vodniki statorja
7	Kabel toplotnega tipala

1	Проводници на термосондата
2	Пусково устройство
3	Проводници на моторния кабел
4	Кабел на мотора
5	Клемна кутия на помпата
6	Проводници на статора
7	Кабел на термосондата

1	Проводи термозонда
2	Пристрій запуску
3	Проводи кабелю двигуна
4	Кабель двигуна
5	Клемна коробка на насосі
6	Кабелі статора
7	Кабель термозонда

1	موصلات المجس الحراري
2	جهاز بدء التشغيل
3	موصلات كابل المحرك
4	كابل المحرك
5	علبة أقطاب على المضخة
6	موصلات الجزء الثابت
7	كابل المجس الحراري

10.9.2 Colore e marchi dei conduttori di alimentazione - Color and marking of power supply leads - Couleur et repérages des conducteurs d'alimentation - Farbe und Kennzeichnung der Versorgungsleiter - Color y marcas de los conductores de alimentación - Cor e marcas dos condutores de alimentação - Kleur en markering van de voedingsgeleiders - Färg och märkning av matningsledare - Sähköjohtimien värit ja merkinnät - Цвет и торговые марки проводников питания - Χρώμα και μάρκες των αγωγών τροφοδοσίας - Forsyningsledningens farve og symboler - Forsyningsledningens farge og symboler - Kolor i oznaczenia przewodów zasilających - Barva a značky napájecích vodičů - Farba a značky napájacích vodičov - A tápvezetékek színei és jelzései - Barve in oznake napajalnih vodnikov - Culoarea și marcajul conductoarelor de alimentare - Маркировка и цвет на проводниците - Besleme iletkenlerinin renk ve işaretleri - Kolip i marka проводів живлення - الألوان والعلامة التجارية لموصلات التغذية - الألووان والعلامة التجارية لموصلات التغذية

	Cavo 4 conduttori	Cavo 7 conduttori
L1	Marrone	Nero 1
L2	Nero	Nero 2
L3	Grigio	Nero 3
L1	-	Nero 4
L2	-	Nero 5
L3	-	Nero 6
	Giallo/Verde	Giallo/Verde

	Câble 4 conducteurs	Câble 7 conducteurs
L1	Marron	Noir 1
L2	Noir	Noir 2
L3	Gris	Noir 3
L1	-	Noir 4
L2	-	Noir 5
L3	-	Noir 6
	Jaune/Vert	Jaune/Vert

	Cable de 4 conductores	Cable de 7 conductores
L1	Marrón	Negro 1
L2	Negro	Negro 2
L3	Gris	Negro 3
L1	-	Negro 4
L2	-	Negro 5
L3	-	Negro 6
	Amarillo/Verde	Amarillo/Verde

	Kabel met 4 geleiders	Kabel met 7 geleiders
L1	Bruin	Zwart 1
L2	Zwart	Zwart 2
L3	Grijs	Zwart 3
L1	-	Zwart 4
L2	-	Zwart 5
L3	-	Zwart 6
	Geel/Groen	Geel/Groen

	4-johtiminen kaapeli	7-johtiminen kaapeli
L1	Ruskea	Musta 1
L2	Musta	Musta 2
L3	Harmaa	Musta 3
L1	-	Musta 4
L2	-	Musta 5
L3	-	Musta 6
	Keltavihreä	Keltavihreä

	4-lead cable	7-lead cable
L1	Brown	Black 1
L2	Black	Black 2
L3	Grey	Black 3
L1	-	Black 4
L2	-	Black 5
L3	-	Black 6
	Yellow/Green	Yellow/Green

	4-Leiter-Kabel	7-Leiter-Kabel
L1	Braun	Schwarz 1
L2	Schwarz	Schwarz 2
L3	Grau	Schwarz 3
L1	-	Schwarz 4
L2	-	Schwarz 5
L3	-	Schwarz 6
	Gelb/Grün	Gelb/Grün

	Cabo 4 condutores	Cabo 7 condutores
L1	Castanho	Preto 1
L2	Preto	Preto 2
L3	Cinzento	Preto 3
L1	-	Preto 4
L2	-	Preto 5
L3	-	Preto 6
	Amarelo/Verde	Amarelo/Verde

	Kabel 4 ledare	Kabel 7 ledare
L1	Brun	Svart 1
L2	Svart	Svart 2
L3	Grå	Svart 3
L1	-	Svart 4
L2	-	Svart 5
L3	-	Svart 6
	Gulgrön	Gulgrön

	Кабель с 4 проводниками	Кабель с 7 проводниками
L1	Коричневый	Черный 1
L2	Черный	Черный 2
L3	Серый	Черный 3
L1	-	Черный 4
L2	-	Черный 5
L3	-	Черный 6
	Желтый/Зеленый	Желтый/Зеленый

	Καλώδιο 4 αγωγών	Καλώδιο 7 αγωγών
L1	Καφέ	Μαύρο 1
L2	Μαύρο	Μαύρο 2
L3	Γκρι	Μαύρο 3
L1	-	Μαύρο 4
L2	-	Μαύρο 5
L3	-	Μαύρο 6
	Κίτρινο/Πράσινο	Κίτρινο/Πράσινο

	Kabel med 4 ledere	Kabel med 7 ledere
L1	Brun	Sort 1
L2	Sort	Sort 2
L3	Grå	Sort 3
L1	-	Sort 4
L2	-	Sort 5
L3	-	Sort 6
	Gulgrønn	Gulgrønn

	Kabel se 4 vodiči	Kabel se 7 vodiči
L1	Hnědý	Černý 1
L2	Černý	Černý 2
L3	Šedý	Černý 3
L1	-	Černý 4
L2	-	Černý 5
L3	-	Černý 6
	Žlutozelený	Žlutozelený

	4 vezetőkes kábel	7 vezetőkes kábel
L1	Barna	Fekete 1
L2	Fekete	Fekete 2
L3	Szürke	Fekete 3
L1	-	Fekete 4
L2	-	Fekete 5
L3	-	Fekete 6
	Sárga/Zöld	Sárga/Zöld

	Cablu 4 conductoare	Cablu 7 conductoare
L1	Maro	Negru 1
L2	Negru	Negru 2
L3	Gri	Negru 3
L1	-	Negru 4
L2	-	Negru 5
L3	-	Negru 6
	Galben/Verde	Galben /Verde

	4 iletkenli kablo	7 iletkenli kablo
L1	Kahverengi	Siyah 1
L2	Siyah	Siyah 2
L3	Gri	Siyah 3
L1	-	Siyah 4
L2	-	Siyah 5
L3	-	Siyah 6
	Sarı/Yeşil	Sarı/Yeşil

	كابل 4 موصل كهربائي	كابل 7 موصل كهربائي
L1	بنى	أسود 1
L2	أسود	أسود 2
L3	رمادي	أسود 3
L1	-	أسود 4
L2	-	أسود 5
L3	-	أسود 6
	أصفر / أخضر	أصفر / أخضر

	4-ledet kabel	7-ledet kabel
L1	Brun	Sort 1
L2	Sort	Sort 2
L3	Grå	Sort 3
L1	-	Sort 4
L2	-	Sort 5
L3	-	Sort 6
	Gul/grøn	Gul/grøn

	Kabel 4-przewodowy	Kabel 7-przewodowy
L1	Brazowy	Czarny 1
L2	Czarny	Czarny 2
L3	Szary	Czarny 3
L1	-	Czarny 4
L2	-	Czarny 5
L3	-	Czarny 6
	Żółto/zielony	Żółto/zielony

	Kábel so 4 vodičmi	Kábel so 7 vodičmi
L1	Hnědý	Čierny 1
L2	Čierny	Čierny 2
L3	Sivá	Čierny 3
L1	-	Čierny 4
L2	-	Čierny 5
L3	-	Čierny 6
	Žlto-zelený	Žlto-zelený

	4 žilni kabel	7 žilni kabel
L1	Rjava	Črna 1
L2	Črna	Črna 2
L3	Siva	Črna 3
L1	-	Črna 4
L2	-	Črna 5
L3	-	Črna 6
	Rumena/zelena	Rumena/zelena

	Кабел с 4 проводника	Кабел с 7 проводника
L1	Кафяв	Черен 1
L2	Черен	Черен 2
L3	Сив	Черен 3
L1	-	Черен 4
L2	-	Черен 5
L3	-	Черен 6
	Жълт/Зелен	Жълт/Зелен

	Кабель на 4 проводя	Кабель на 7 проводя
L1	Κοριχневий	Чорний 1
L2	Чорний	Чорний 2
L3	Сірий	Чорний 3
L1	-	Чорний 4
L2	-	Чорний 5
L3	-	Чорний 6
	Жовтий/Зелений	Жовтий/Зелений

10.9.3 Colore e marchi dei conduttori della sonda termica - Colour and markings of heat sensor leads - Couleur et repérages des conducteurs de la sonde thermique - Farbe und Kennzeichnung der Temperaturfühler Leiter - Color y marcas de los conductores de la sonda térmica - Cor e marcas dos condutores das sondas térmicas - Kleur en markering van de geleiders van de thermische voeler - Färg och märkning av värmegivarens ledare - Lämpöanturin johtimien värit ja merkinnät - Цвет и торговые марки проводников температурного зонда - Χρώμα και μάρκες των αγωγών του θερμικού αισθητήρα - Farver og symboler for ledere i termisk sonde - Farger og symboler for ledere i varmesonde - Kolor i oznaczenia przewodów sondy termicznej - Barva a značky vodičů teplotní sondy - Farba a značky vodičov teplotnej sondy - A hőszonda vezetékeinek színei és jelzései - Barve in oznake vodnikov toplotnega tipala - Culoarea și marcajul conductoarelor senzorului termic - Маркировка и цвет на проводниците на термосондата - Isı probu iletkenlerinin renk ve işaretleri - Колір і марка проводів термозонда - الألوان والعلامة التجارية لموصلات المجس الحراري

SUBCAB	
T1	Bianco T1
T2	Bianco T2

SUBCAB	
T1	White T1
T2	White T2

SUBCAB	
T1	Blanc T1
T2	Blanc T2

SUBCAB	
T1	Weiß T1
T2	Weiß T2

SUBCAB	
T1	Blanco T1
T2	Blanco T2

SUBCAB	
T1	Branco T1
T2	Branco T2

SUBCAB	
T1	Wit T1
T2	Wit T2

SUBCAB	
T1	White T1
T2	White T2

SUBCAB	
T1	Valkoinen T1
T2	Valkoinen T2

SUBCAB	
T1	Белый T1
T2	Белый T2

SUBCAB	
T1	Λευκό T1
T2	Λευκό T2

SUBCAB	
T1	Hvid T1
T2	Hvid T2

SUBCAB	
T1	Hvít T1
T2	Hvít T2

SUBCAB	
T1	Biały T1
T2	Biały T2

SUBCAB	
T1	Bílý T1
T2	Bílý T2

SUBCAB	
T1	Biely T1
T2	Biely T2

SUBCAB	
T1	Fehér T1
T2	Fehér T2

SUBCAB	
T1	Bela T1
T2	Bela T2

SUBCAB	
T1	Alb T1
T2	Alb T2

SUBCAB	
T1	Бял T1
T2	Бял T2

SUBCAB	
T1	Beyaz T1
T2	Beyaz T2

SUBCAB	
T1	Білий T1
T2	Білий T2

SUBCAB	
T1	أبيض T1
T2	أبيض T2

10.9.4 Colore e marchi dei conduttori dello statore - Colour and marking of stator leads - Couleur et repérages des conducteurs du stator - Farbe und Kennzeichnung der Stator Kabel - Color y marcas de los conductores del estator - Cor e marcas dos condutores do estator - Kleur en marking van de geleiders van de stator - Färg och märkning av statorledare - Staattorin johtimien värit ja merkinnät - Цвет и торговые марки проводников статора - Χρώμα και μάρκες των αγωγών του στάτορα - Farver og symboler for ledere i stator - Farge og symboler for ledere i stator - Kolor i oznaczenia przewodów stojanu - Barva a značky vodičů statoru - Farba a značky vodičov statora - Az állórész vezetőkeinek színe és jelzései - Barve in oznake vodnikov statorja - Culoarea și marcajul conductoarelor statorului - Маркировка и цвет на проводниците на статора - Stator iletkenlerinin renk ve işaretleri - Колір і марка проводів статора - الألوان والعلامة التجارية لموصلات الجزء الثابت

Conessioni Statore	Colore conduttore	
	3 ~	1 ~
U1	Rosso	Rosso
U2	Verde	Marrone
U5	Rosso	Giallo
U6	-	Verde
V1	Marrone	-
V2	Blu	-
V5	Marrone	-
W1	Giallo	-
W2	Nero	-
W5	Giallo	Giallo
Z1	-	Blu
Z2	-	Nero
Z5	-	Rosso

Stator Connection	Lead color	
	3 ~	1 ~
U1	Red	Red
U2	Green	Brown
U5	Red	Yellow
U6	-	Green
V1	Brown	-
V2	Blue	-
V5	Brown	-
W1	Yellow	-
W2	Black	-
W5	Yellow	Yellow
Z1	-	Blue
Z2	-	Black
Z5	-	Red

Branchements Stator	Couleur conducteur	
	3 ~	1 ~
U1	Rouge	Rouge
U2	Vert	Marron
U5	Rouge	Jaune
U6	-	Vert
V1	Marron	-
V2	Bleu	-
V5	Marron	-
W1	Jaune	-
W2	Noir	-
W5	Jaune	Jaune
Z1	-	Bleu
Z2	-	Noir
Z5	-	Rouge

Stator Anschlüsse	Farbe des Leiters	
	3 ~	1 ~
U1	Rot	Rot
U2	Grün	Braun
U5	Rot	Gelb
U6	-	Grün
V1	Braun	-
V2	Blau	-
V5	Braun	-
W1	Gelb	-
W2	Schwarz	-
W5	Gelb	Gelb
Z1	-	Blau
Z2	-	Schwarz
Z5	-	Rot

Conexiones Estator	Color del conductor	
	3 ~	1 ~
U1	Rojo	Rojo
U2	Verde	Marrón
U5	Rojo	Amarillo
U6	-	Verde
V1	Marrón	-
V2	Azul oscuro	-
V5	Marrón	-
W1	Amarillo	-
W2	Negro	-
W5	Amarillo	Amarillo
Z1	-	Azul oscuro
Z2	-	Negro
Z5	-	Rojo

Ligações Estator	Cor do condutor	
	3 ~	1 ~
U1	Vermelho	Vermelho
U2	Verde	Castanho
U5	Vermelho	Amarelo
U6	-	Verde
V1	Castanho	-
V2	Azul	-
V5	Castanho	-
W1	Amarelo	-
W2	Preto	-
W5	Amarelo	Amarelo
Z1	-	Azul
Z2	-	Preto
Z5	-	Vermelho

Aansluitingen Stator	Kleur geleider	
	3 ~	1 ~
U1	Rood	Rood
U2	Groen	Bruin
U5	Rood	Geel
U6	-	Groen
V1	Bruin	-
V2	Blauw	-

Statoranslutning	Ledarfärg	
	3 ~	1 ~
U1	Röd	Röd
U2	Grön	Brun
U5	Röd	Gul
U6	-	Grön
V1	Brun	-
V2	Blå	-

V5	Bruin	-
W1	Geel	-
W2	Zwart	-
W5	Geel	Geel
Z1	-	Blauw
Z2	-	Zwart
Z5	-	Rood

V5	Brun	-
W1	Gul	-
W2	Svart	-
W5	Gul	Gul
Z1	-	Blå
Z2	-	Svart
Z5	-	Röd

Staattorin liitännät	Johtimen väri	
	3 ~	1 ~
U1	Punainen	Punainen
U2	Vihreä	Ruskea
U5	Punainen	Keltainen
U6	-	Vihreä
V1	Ruskea	-
V2	Sininen	-
V5	Ruskea	-
W1	Keltainen	-
W2	Musta	-
W5	Keltainen	Keltainen
Z1	-	Sininen
Z2	-	Musta
Z5	-	Punainen

Соединения статора	Цвет проводника	
	3 ~	1 ~
U1	Красный	Красный
U2	Зеленый	Коричневый
U5	Красный	Желтый
U6	-	Зеленый
V1	Коричневый	-
V2	Синий	-
V5	Коричневый	-
W1	Желтый	-
W2	Черный	-
W5	Желтый	Желтый
Z1	-	Синий
Z2	-	Черный
Z5	-	Красный

Συνδέσεις Στάτορας	Χρώμα αγωγού	
	3 ~	1 ~
U1	Κόκκινο	Κόκκινο
U2	Πράσινο	Καφέ
U5	Κόκκινο	Κίτρινο
U6	-	Πράσινο
V1	Καφέ	-
V2	Μπλε	-
V5	Καφέ	-
W1	Κίτρινο	-
W2	Μαύρο	-
W5	Κίτρινο	Κίτρινο
Z1	-	Μπλε
Z2	-	Μαύρο
Z5	-	Κόκκινο

Statorens tilslutning	Lederens farve	
	3 ~	1 ~
U1	Rød	Rød
U2	Grøn	Brun
U5	Rød	Gul
U6	-	Grøn
V1	Brun	-
V2	Blå	-
V5	Brun	-
W1	Gul	-
W2	Sort	-
W5	Gul	Gul
Z1	-	Blå
Z2	-	Sort
Z5	-	Rød

Statorens tilkøplinger	Lederens farge	
	3 ~	1 ~
U1	Rød	Rød
U2	Grønn	Brun
U5	Rød	Gul
U6	-	Grønn
V1	Brun	-
V2	Blå	-
V5	Brun	-
W1	Gul	-
W2	Sort	-
W5	Gul	Gul
Z1	-	Blå
Z2	-	Sort
Z5	-	Rød

Połączenia Stojan	Kolor przewodu	
	3 ~	1 ~
U1	Czerwony	Czerwony
U2	Zielony	Brązowy
U5	Czerwony	Żółty
U6	-	Zielony
V1	Brązowy	-
V2	Niebieski	-
V5	Brązowy	-
W1	Żółty	-
W2	Czarny	-
W5	Żółty	Żółty
Z1	-	Niebieski
Z2	-	Czarny
Z5	-	Czerwony

Zapojení Stator	Barva vodiče	
	3 ~	1 ~
U1	Červený	Červený
U2	Zelený	Hnědý
U5	Červený	Žlutý
U6	-	Zelený
V1	Hnědý	-
V2	Modrý	-
V5	Hnědý	-
W1	Žlutý	-
W2	Černý	-

Zapojenia Stator	Farba vodiča	
	3 ~	1 ~
U1	Červený	Červený
U2	Zelený	Hnedý
U5	Červený	Žltý
U6	-	Zelený
V1	Hnedý	-
V2	Modrý	-
V5	Hnedý	-
W1	Žltý	-
W2	Čierny	-

W5	Žlutý	Žlutý
Z1	-	Modrý
Z2	-	Černý
Z5	-	Červený

W5	Žltý	Žltý
Z1	-	Modrý
Z2	-	Čierny
Z5	-	Červený

Állórész Csatlakozások	Vezeték szín 3 ~	1 ~
U1	Piros	Piros
U2	Zöld	Barna
U5	Piros	Sárga
U6	-	Zöld
V1	Barna	-
V2	Kék	-
V5	Barna	-
W1	Sárga	-
W2	Fekete	-
W5	Sárga	Sárga
Z1	-	Kék
Z2	-	Fekete
Z5	-	Piros

Povezave Stator	Barva vodnika 3 ~	1 ~
U1	Rdeča	Rdeča
U2	Zelena	Rjava
U5	Rdeča	Rumena
U6	-	Zelena
V1	Rjava	-
V2	Modra	-
V5	Rjava	-
W1	Rumena	-
W2	Črna	-
W5	Rumena	Rumena
Z1	-	Modra
Z2	-	Črna
Z5	-	Rdeča

Conectori Stator	Culoare conductor 3 ~	1 ~
U1	Roșu	Roșu
U2	Verde	Maro
U5	Roșu	Galben
U6	-	Verde
V1	Maro	-
V2	Albastru	-
V5	Maro	-
W1	Galben	-
W2	Negru	-
W5	Galben	Galben
Z1	-	Albastru
Z2	-	Negru
Z5	-	Roșu

Свързки статор	Цвят на проводника 3 ~	1 ~
U1	Червен	Червен
U2	Зелен	Кафяв
U5	Червен	Жълт
U6	-	Зелен
V1	Кафяв	-
V2	Син	-
V5	Кафяв	-
W1	Жълт	-
W2	Черен	-
W5	Жълт	Жълт
Z1	-	Син
Z2	-	Черен
Z5	-	Червен

Stator Bağlantıları	İletkenin rengi 3 ~	1 ~
U1	Kırmızı	Kırmızı
U2	Yeşil	Kahverengi
U5	Kırmızı	Sarı
U6	-	Yeşil
V1	Kahverengi	-
V2	Mavi	-
V5	Kahverengi	-
W1	Sarı	-
W2	Siyah	-
W5	Sarı	Sarı
Z1	-	Mavi
Z2	-	Siyah
Z5	-	Kırmızı

З'єднання статора	Колір проводу 3 ~	1 ~
U1	Червоний	Червоний
U2	Зелений	Коричневий
U5	Червоний	Жовтий
U6	-	Зелений
V1	Коричневий	-
V2	Синій	-
V5	Коричневий	-
W1	Жовтий	-
W2	Чорний	-
W5	Жовтий	Жовтий
Z1	-	Синій
Z2	-	Чорний
Z5	-	Червоний

التوصيلات الجزء الثابت	لون الموصل الكهربائي ~ 3	~ 1
U1	أحمر	أحمر
U2	أخضر	بنّي
U5	أحمر	أصفر
U6	-	أخضر
V1	بنّي	-
V2	أزرق	-
V5	بنّي	-
W1	أصفر	-
W2	أسود	-
W5	أصفر	أصفر
Z1	-	أزرق
Z2	-	أسود
Z5	-	أحمر

10.9.5 Schema connessione cavo 4 conduttori, monofase - Connection scheme 4-lead cable, single-phase - Schéma de branchement câble 4 conducteurs, monophasé - Anschlussplan 4-Leiter-Kabel, einphasig - Esquema de conexión del cable de 4 conductores, monofásico - Esquema da ligação cabo 4 condutores, monofásico - Aansluitschema kabel met 4 geleiders, monofase - Kopplingsschema kabel 4 ledare, enfas - Yksivaiheisen 4-johtimisen kaapelin liitántäkaavio - Схема соединения кабеля с 4 проводниками, однофазная - Σχέδιο σύνδεσης καλωδίου 4 αγωγών, μονοφασικά - Elskema vedrørende 4-ledet kabel (enkeltfaset) - Koplingsskjema for kabel med 4 ledere (enfaset) - Schemat połączenia kabel 4-przewodowy, jednofazowy - Schéma zapojení kabelu se 4 vodiči, jednofázová verze - Schéma zapojenia kábla so 4 vodičmi, jednofázová verzia - 4 vezetékes, egyfázisú kábel csatlakozási ábrája - Shema povezave 4 žilnega kabla, enofazno - Schema de conectare a cablului cu 4 conductoare (varianta monofazată) - Схема за свързване на кабел с 4 проводника, еднофазов - 4 iletkenli kablo bağlantı şeması, monofaze - Схема з'єднання кабелю на 4 проводи, монофазна - مخطط توصيل كابل 4 موصل كهربائي، أحادي الطور

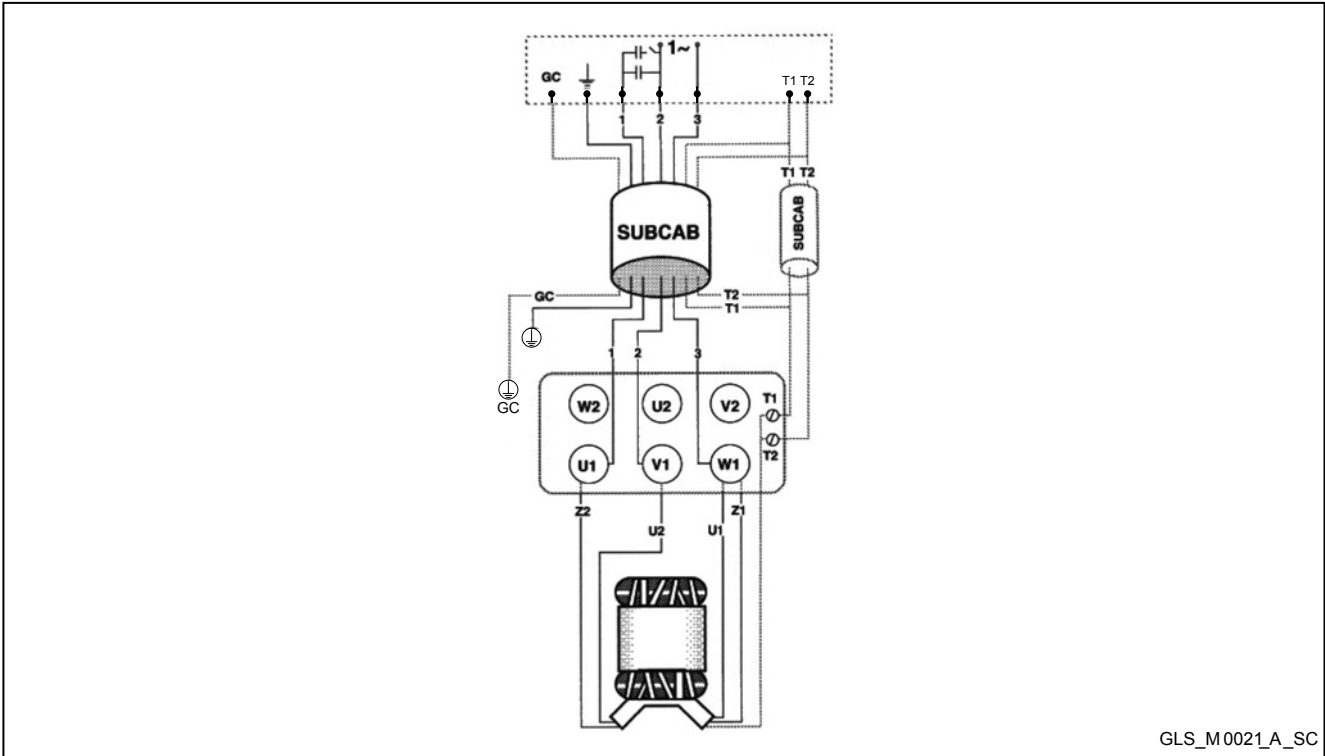

GLS_M0021_A_SC

10.9.6 Schema connessione stella cavo 4 conduttori, trifase - Star connection scheme 4-lead cable, three-phase - Schéma de montage en étoile câble 4 conducteurs, triphasé - Anschlussplan Sternschaltung 4-Leiter-Kabel, dreiphasig - Esquema de conexión estrella del cable de 4 conductores, trifásico - Esquema da ligação estrela cabo 4 condutores, trifásico - Ster aansluitschema kabel met 4 geleiders, driefase - Stjärnanslutningsschema kabel 4 ledare, trefas - Kolmivaiheisen 4-johtimisen kaapelin tähtiliitännäkaavio - Схема соединения звездой кабеля с 4 проводниками, трехфазная - Σχέδιο σύνδεσης αστερία καλωδίου 4 αγωγών, τριφασικά - Elskema vedrørende 4-ledet kabel (trefaset med stjerne starter) - Kopleingsskjema for kabel med 4 ledere (trefaset med stjerne starter) - Schemat połączenia gwiazdy kabel 4-przewodowy, trójfazowy - Schéma zapojení hvězdy kabelu se 4 vodiči, třífázová verze - Schéma zapojenia hviezda kábla so 4 vodičmi, trojfázová verzia - 4 vezetékes, háromfázisú kábel csillag csatlakozási ábrája - Shema zvezdne povezave 4 žilnega kabla, trifazno - Schema de conectare stea a cablului cu 4 conductoare (varianta trifazată) - Схема за свързване звезда, кабел с 4 проводника, трифазов - 4 iletkenli kablo yıldız bağlantı şeması, trifaze - Схема з'єднання зірки кабелю на 4 проводи, трьохфазна - مخطط التوصيل النجمة كابل 4 موصل كهربائي، ثلاثي الطور

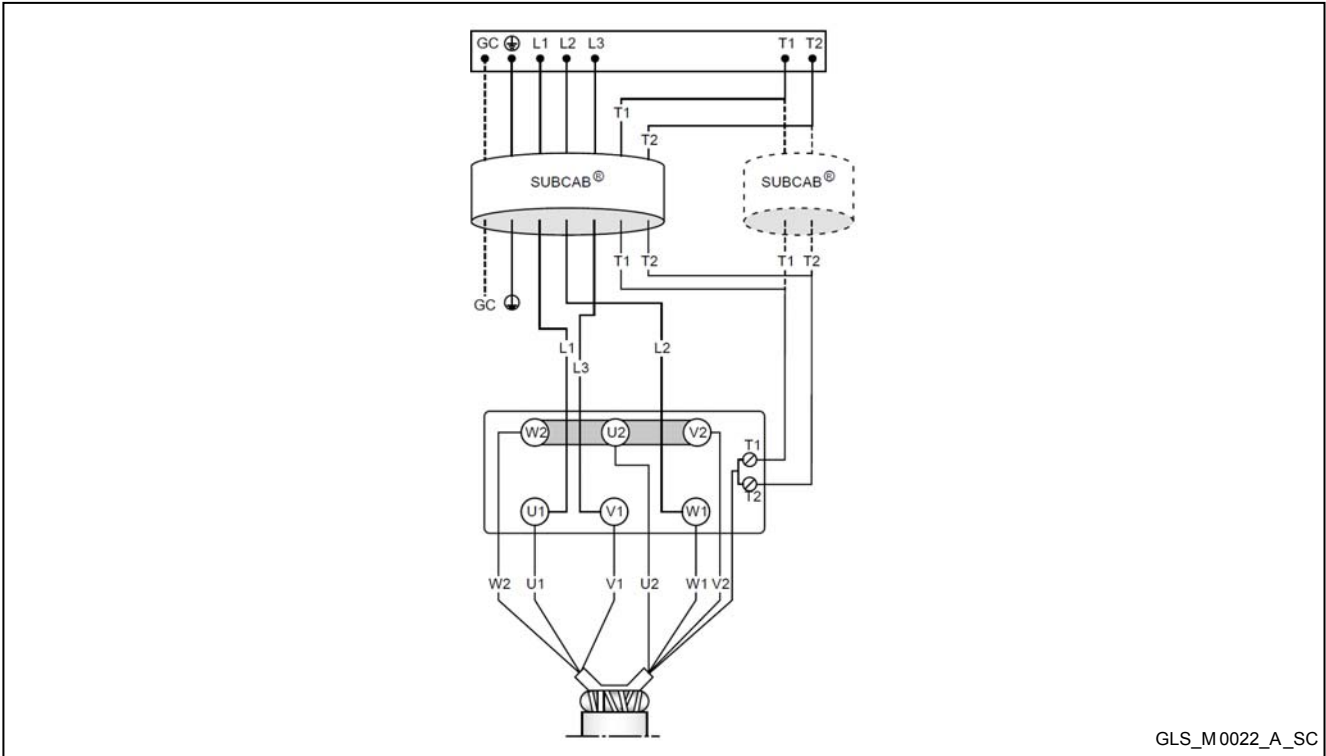

GLS_M0022_A_SC

10.9.7 Schema connessione stella/triangolo cavo 7 conduttori, trifase - Star/delta connection scheme 7-lead cable, three-phase - Schéma de montage en étoile/triangle câble 7 conducteurs, triphasé - Anschlussplan Stern-/Dreieckschaltung 7-Leiter-Kabel, dreiphasig - Esquema de conexión estrella/triángulo del cable de 7 conductores, trifásico - Esquema da ligação estrela/triângulo cabo 7 condutores, trifásico - Ster/driehoek aansluitschema kabel met 7 geleiders, driefase - Stjärn-triangelslutningsschema kabel 4 ledare, trefas - Kolmivaiheisen 7-johtimisen kaapelin tähti/kolmioliitintäkaavio - Схема соединения звезда/треугольник кабеля с 7 проводниками, трехфазная - Σχέδιο σύνδεσης αστερία /τριγώνου καλωδίου 7 αγωγών, τριφασικά - Elskema vedrørende 7-ledet kabel (trefaset med stjerne/trekant starter) - Koplingsskjema for kabel med 7 ledere (trefaset med stjerne/trekant starter) - Schemat połączenia gwiazdy/trójkąta kabel 7-przewodowy, trójfazowy - Schéma zapojení hvězda/trojúhelník kabelu se 7 vodiči, třífázová verze - Schéma zapojenia hviezda/trojuholník kábla so 7 vodičmi, trojfázová verzia - 7 vezetékes, háromfázisú kábel csillag/háromszög csatlakozási ábrája - Shema zvezdne/trikotne povezave 7 žilnega kabla, trifazno - Schema de conectare stea-triunghi a cablului cu 7 conductoare (varianta trifazată) - Схема за свързване звезда/триъгълник, кабел с 7 проводника, трифазов - 7 iletkenli kablo yıldız-üçgen bağlantı şeması, trifaze - Схема з'єднання зірки/трикутника для кабелю на 7 проводи, трьохфазна - مخطط التوصيل النجمة / المثلث - كابل 7 موصل كهربائي، ثلاثي الطور

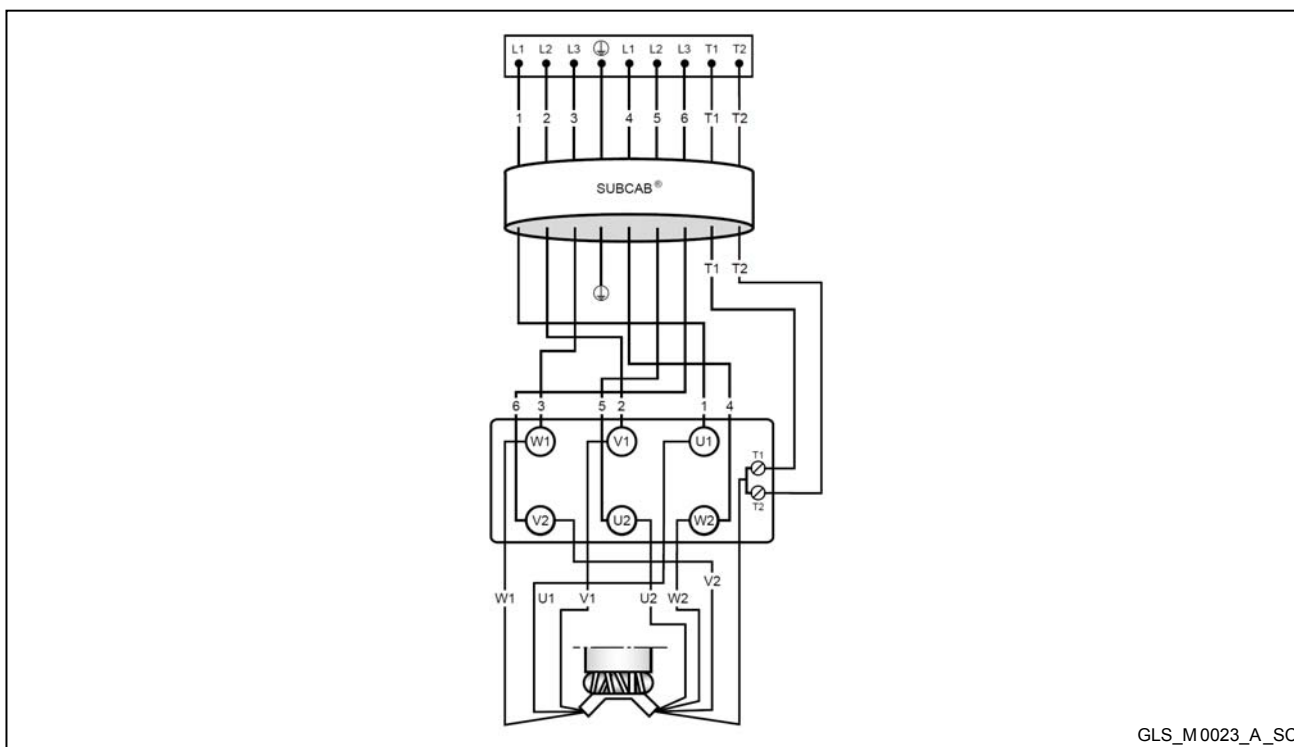

GLS_M0023_A_SC

10.10 Senso di rotazione corretto - Correct impeller direction - Sens de rotation correct - Korrekte Drehrichtung - Sentido de rotación correcto - Sentido de rotação correcto - Juiste draairichting - Korrekt rotationsriktning - Oikea pyörimissuunta - Правильное направление вращения - Ορθή φορά περιστροφής - Korrekt rotationsretning - Riktig rotasjonsretning - Prawidłowy kierunek obrotu - Správny směr otáčení - Správny smer otáčania - Helyes forgási irány - Pravilna smer vrtenja - Sensul de rotație corect - Правильна посока на ротация - Doğru dönüş yönü - اتجاه الدوران الصحيح

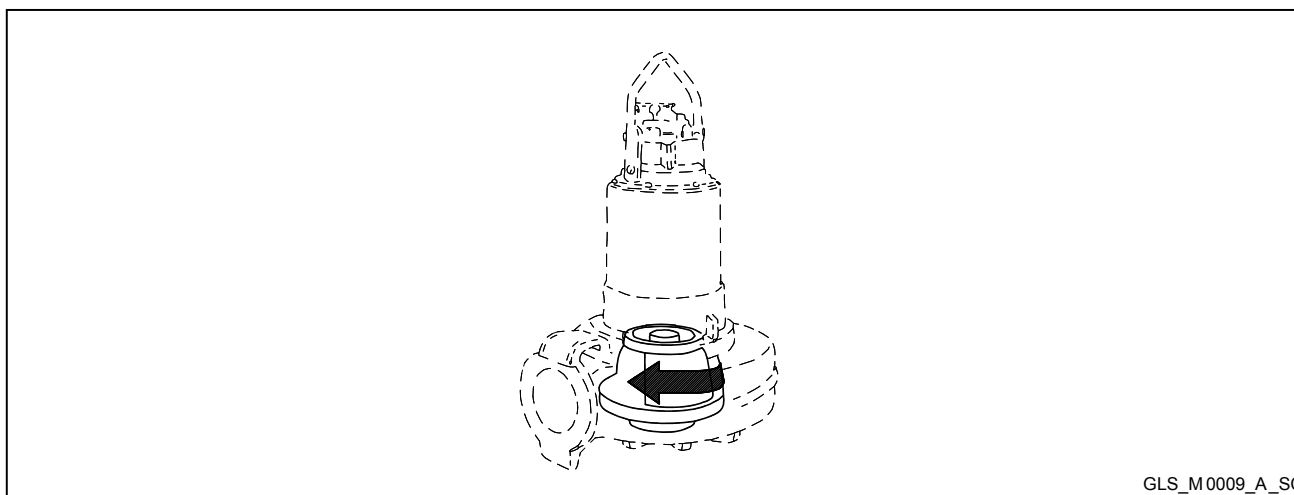

GLS_M0009_A_SC

10.11 Coppie di serraggio - Tightening torques - Couples de serrage - Anzugsmoment - Pares de apriete - Binários de aperto - Aanhaalkoppels - Åtdragningsmoment - Vääntömomentit - Крутящие моменты - Ροπές σύσφιξης - Tilspændingsmomenter - Strammemoment - Moment dokręcania - Uťahovací moment - Ut'ahovací moment - Rögzítési nyomaték - Momenti pritvitja - Cupluri de strângere - Двойки закрепващи болтове - Sıkma torkları - Моменти затягування - عزم دوران التثبيت

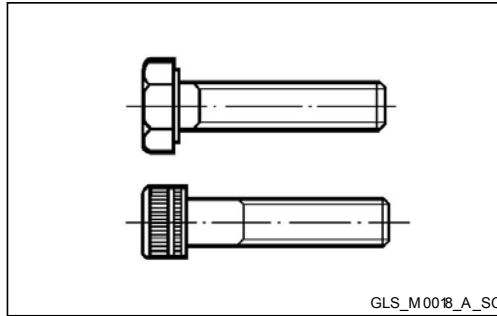

Acciaio inossidabile, A2 e A4 - Stainless steel, A2 and A4 - Acier inoxydable, A2 et A4 - Rostfreier Stahl, A2 und A4 - Acero inoxidable, A2 y A4 - Aço inoxidável, A2 e A4 - Roestvast staal A2 en A4 - Rostfritt stål, A2 och A4 - Ruostumaton teräs, A2 ja A4 - Нержавеющая сталь, A2 и A4 - Χάλυβας ανοξειδωτος, A2 και A4 - Rustfrit stål, A2 og A4 - Rustfritt stål, A2 og A4 - Stal nierdzewna, A2 i A4 - Nerezová ocel, A2 a A4 - Nehrdzavejúca ocel', A2 a A4 - Rozsdamentes acél, A2 és A4 - Nerjavno jeklo, A2 in A4 - Oţel inoxidabil, A2 şi A4 - Неръждаема стомана, A2 и A4 - Paslanmaz çelik, A2 ve A4 - Нержавіюча сталь, A2 і A4 - A2 و A4 الاستانلس ستيل

	Classe - Class - Classe - Klasse - Clase - Class- Klasse - Klass Luokka - Класс - Κατηγορία - Klasse - Klasse - Klasa - Třída - Trieda - Osztály - Razred - Clasă - Клас - Sınıf - Ступінь затягування - النوع	M4	M5	M6	M8	M10	M12	M16	M20	M24	M30
Coppia [Nm] Torque [Nm] Couple [Nm] Anzugsmoment [Nm] Par [Nm] Binário [Nm] Koppel [Nm] Åtdr.moment [Nm] Momentti (Nm) Крутящий момент [Нм] Ροπή [Nm] Tilspændingsmoment (Nm) Strammemoment (Nm) Moment dokręcania [Nm] Moment [Nm] Nyomaték [Nm] Moment [Nm] Cuplu [Nm] Двойка [Nm] Tork [Nm] Пара [Nm] عزم دوران التثبيت [نيوتن متر]	70 + 80 *	2.7	5.4	9.3	22	44	76	187	364	629	1240

* La viteria di classe 70 viene serrata come la classe 80 - Class 70 screws is torque tightened as class 80 - Les couples de serrage sont les mêmes pour la classe 70 et la classe 80 - Die Schrauben der Klasse 70 haben das gleiche Anzugsmoment wie die Schrauben der Klasse 80 - Los tornillos de clase 70 se aprietan como la clase 80 - Os parafusos da classe 70 são

apertados como os da classe 80 - De schroeven van klasse 70 worden aangehaald als klasse 80 - Skruvar i klass 70 dras åt på samma sätt som 80 - Luokan 70 ruuvit kiristetään samoin kuin luokan 80 ruuvit - Винты класса 70 закручиваются также, как класс 80 - Οι βίδες κατηγορίας 70 σφίγγονται όπως της κατηγορίας 80 - Skruer og beslag i klasse 70 skal fastspændes jf. klasse 80 - Skruer og mutrer i klasse 70 må strammes som klasse 80 - Łączniki gwintowe klasy 70 są dokręcane jako klasa 80 - Šrouby třídy 70 jsou utahovány jako třída 80 - Skrutky triedy 70 sú utahované ako trieda 80 - A 70-es osztályú csavarokat ugyanúgy kell rögzíteni, mint a 80-as osztályú csavarokat - Vijaki razreda 70 se pritegne kot razred 80 - Şuruburile de clasa 70 se strâng ca şi cele de clasa 80 - Винтовете от клас 70 се затягат по същия начин като клас 80 - Набір гвинтів і болтів - Sınıf 70 vidalar sınıf 80 vidalar gibi sıkılır - клас 70, затягування здійснюється як для класу 80 - المسامير والمسامير الملولب من الفئة 70 تستخدم في الإغلاق كالفئة 80 - كربوني، صلب سبيكة

Acciaio al carbonio, acciaio legato - Carbon steel and alloyed steel - Acier au carbone, acier allié - Kohlenstoffstahl und legierter Stahl - Acero al carbono, acero aleado - Aço carbono, aço ligado - Koolstofstaal en gelegeerd staal - Kolstål och legerat stål - Hiilitteräs, erikoisteräs - Углеродистая сталь, легированная сталь - Χάλυβας με άνθρακα, χάλυβας δεμένος - Kulstål, legeret stål - Kullstål, legert stål - Stal węglowa, stal stopowa - Uhlíková ocel, legovaná ocel - Uhlíková ocel', legovaná ocel' - Szénacél, ötvöztött acél - Ogljikovo jeklo, legirano jeklo - Oțel carbon, oțel aliat - Вуглеродна стомана, стоманена сплав - Karbon çeliği, alaşimli çelik - Вуглецева сталь, легована сталь - كربوني، صلب سبيكة											
	Classe - Class - Classe - Klasse - Clase - Class- Klasse - Klass - Luokka - Класс - Κατηγορία - Klasse - Klasse - Klasa - Třída - Trieda - Osztály - Razred - Clasă - Клас - Sınıf - Ступінь затягування - النوع	M4	M5	M6	M8	M10	M12	M16	M20	M24	M30
Coppia [Nm] Torque [Nm] Couple [Nm] Anzugsmoment [Nm] Par [Nm] Binário [Nm] Koppel [Nm] Åtdr.moment [Nm] Momentti (Nm) Крутящий момент [Нм] Ροπή [Nm] Tilspændingsmoment (Nm) Strammemoment (Nm) Moment dokręcania [Nm] Moment [Nm] Nyomaték [Nm] Moment [Nm] Cuplu [Nm] Двойка [Nm] Tork [Nm] Пара [Nm] عزم دوران التثبيت [نيوتن متر]	8.8	2.9	5.7	9.8	24	47	81	194	385	665	1310
	10.9	4.0	8.1	14	33	65	114	277	541	935	1840
	12.9	4.9	9.7	17	40	79	136	333	649	1120	2210

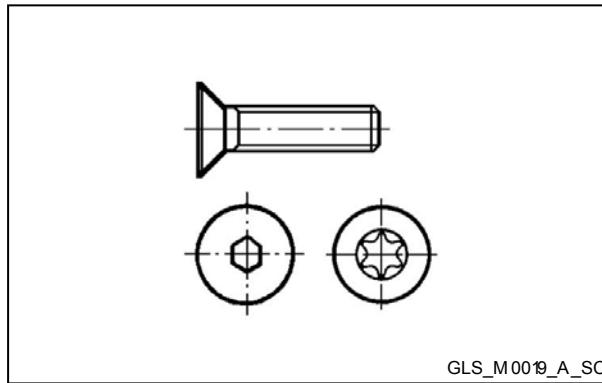

Acciaio inossidabile, A2 e A4 - Stainless steel, A2 and A4 - Acier inoxydable, A2 et A4 - Rostfreier Stahl, A2 und A4 - Acero inoxidable, A2 y A4 - Aço inoxidável, A2 e A4 - Roestvast staal, A2 en A4 - Rostfritt stål, A2 och A4 - Ruostumaton teräs, A2 ja A4 - Нержавеющая сталь, A2 и A4 - Χάλυβας ανοξείδωτος, A2 e A4 - Rustfrit stål, A2 og A4 - Rustfritt stål, A2 og A4 - Stal nierdzewna, A2 i A4 - Nerezová ocel, A2 a A4 - Nehrdzavejúca ocel, A2 a A4 - Rozsdamentes acél, A2 és A4 - Nerjavno jeklo, A2 in A4 - Oţel inoxidabil, A2 şi A4 - Неръждаема стомана, A2 и A4 - Paslanmaz çelik, A2 ve A4 - Нержавіюча сталь, A2 і A4 - A2 و A4 الاستانلس ستیل

	Classe - Class - Classe - Klasse - Clase - Class- Klasse - Klass - Luokka - Класс - Κατηγορία - Klasse - Klasse - Klasa - Třída - Trieda - Osztály - Razred - Clasă - Клас - Sınıfı - Ступінь затягування - النوع	M4	M5	M6	M8	M10	M12	M16	M20	M24
Coppia [Nm] Torque [Nm] Couple [Nm] Anzugsmoment [Nm] Par [Nm] Binário [Nm] Koppel [Nm] Åtdr.moment [Nm] Momentti (Nm) Крутящий момент [Нм] Ροπή [Nm] Tilspændingsmoment (Nm) Strammemoment (Nm) Moment dokrećania [Nm] Moment [Nm] Nyomaték [Nm] Moment [Nm] Сирлу [Nm] Двойка [Nm] Tork [Nm] Пара [Nm] عزم دوران التثبيت [نيوتن متر]	70 + 80 *	1.2	2.7	5.4	9.3	22	44	76	120	187

* La viteria di classe 70 viene serrata come la classe 80 - Class 70 screws is torque tightened as class 80 - Les couples de serrage sont les mêmes pour la classe 70 et la classe 80 - Die Schrauben der Klasse 70 haben das gleiche Anzugsmoment wie die Schrauben der Klasse 80 - Los tornillos de clase 70 se aprietan como la clase 80 - Os parafusos da classe 70 são apertados como os da classe 80 - De schroeven van klasse 70 worden aangehaald als klasse 80 - Skruvar i klasse 70 dras åt på samma sätt som 80 - Luokan 70 ruuvit kiristetään samoin kuin luokan 80 ruuvit - Винты класса 70 закручиваются также, как класс 80 - Οι βίδες κατηγορίας 70 σφίγγονται όπως της κατηγορίας 80 - Skruer og beslag i klasse 70 skal

fastspændes jf. klasse 80 - Skruer og mutrer i klasse 70 må strammes som klasse 80 - Łączniki gwintowe klasy 70 są dokręcane jako klasa 80 - Šrouby třídy 70 jsou utahovány jako třída 80 - Skrutky triedy 70 sú utáňované ako trieda 80 - A 70-es osztályú csavarokat ugyanúgy kell rögzíteni, mint a 80-as osztályú csavarokat - Vijaki razreda 70 se pritegne kot razred 80 - Şuruburile de clasa 70 se strâng ca şi cele de clasa 80 - Винтовете от клас 70 се затягат по същия начин като клас 80 - Набір гвинтів і болтів - Sınıf 70 vidalar sınıf 80 vidalar gibi sıkılır - клас 70, затягування здійснюється як для класу 80 - المسمار والمولب من الفئة 70 تستخدم في الإغلاق كالفئة 80

Acciaio al carbonio, acciaio legato - Carbon steel and alloyed steel - Acier au carbone, acier allié - Kohlenstoffstahl und legierter Stahl - Acero al carbono, acero aleado - Aço carbono, aço ligado - Koolstofstaal en gelegeerd staal - Kulstål och legerat stål - Hiiliteräs, erikoisteräs - Углеродистая сталь, легированная сталь - Χάλυβας με άνθρακα, χάλυβας δεμένος - Kulstål, legeret stål - Kullstål, legert stål - Stal węglowa, stal stopowa - Uhlíková ocel, legovaná ocel - Uhlíková ocel', legovaná ocel' - Szénacél, ötvöztött acél - Ogljikovo jeklo, legirano jeklo - Otel carbon, otel aliat - Вуглеродна стомана, стоманена сплав - Karbon çeliği, alaşimli çelik - Вуглецева сталь, легована сталь - صلب (سبيكة) كربوني، صلب (سبيكة)											
	Classe - Class - Classe - Klasse - Clase - Class- Klasse - Klass - Luokka - Класс - Категория - Klasse - Klasse - Klasa - Třída - Trieda - Osztály - Razred - Clasă - Клас - Sınıf - Ступінь затягування - النوع	M4	M5	M6	M8	M10	M12	M16	M20	M24	
Coppia [Nm] Torque [Nm] Couple [Nm] Anzugsmoment [Nm] Par [Nm] Binário [Nm] Koppel [Nm] Átdr.moment [Nm] Momentti (Nm) Крутящий момент [Нм] Ροπή [Nm] Tilspændingsmoment (Nm) Strammemoment (Nm) Moment dokręcania [Nm] Moment [Nm] Nyomaték [Nm] Moment [Nm] Cuplu [Nm] Двойка [Nm] Tork [Nm] Пара [Nm] عزم دوران التثبيت [نيوتن متر]	8.8	2.3	4.6	7.8	19	38	65	158	308	532	
	10.9	3.2	6.5	11	26	52	91	222	433	748	
	12.9	3.9	7.8	14	32	63	109	266	519	896	

10.12 Cambiare l'olio - Change the oil - Vidange de l'huile - Ölwechsel - Cambiar el aceite - Mudar o óleo - Olie perverser - Byt olja - Öljyn vaihto - Замена масла - Αλλάξετε το λάδι - Olieskift - Oljeskift - Wymienić olej - Výměna oleje - Výměna oleja - Olajcsere - Menjava olja - Înlocuirea uleiului - Смяна на маслото - Yağın değiştirilmesi - Замена мастила - تغيير الزيت

Versione 1 tappo - 1 plug version - version 1 bouchon - Version mit 1 Schraube - Versión de 1 tapón - Versão 1 tampão - Model met 1 stop - Version med 1 plugg - Yhden tulpan versio - Модель 1 пробка - Έκδοση 1 πώματος - Version med en prop - Utgave med 1 plugg - Wersja z 1 korkiem - Verze s 1 zátkou - Verzia s 1 zátkou - 1 sapkás változat - Različica z 1 čepom - Varianta cu 1 dop - Вариант с 1 тапа - 1 tapalı versiyon - Варіант з одною кришкою - نوع مزود بسدادتين

Versione 2 tappi - 2 plugs version - version 2 bouchons - Version mit 2 Schrauben - Versión de 2 tapones - Versão 2 tampões - Model met 2 stoppen - Version med 2 pluggar - Kahden tulpan versio - Модель 2 пробки - Έκδοση 2 πωμάτων - Version med to propper - Utgave med 2 pluggar - Wersja z 2 korkami - Verze se 2 zátkami - Verzia s 2 zátkami - 2 sapkás változat - Različica z 2 čepoma - Varianta cu 2 dopuri - Вариант с 2 тапи - 2 tapalı versiyon - Варіант з двома кришками - نوع مزود بسدادة واحدة

Posizione tappi - Plugs position - Position bouchons - Position der Verschlusschrauben - Posición de los tapones - Posição dos tampões - Positie van de stoppen - Pluggarnas position - Tulppien sijoittelu - Положение пробок - Θέση πωμάτων - Proppernes position - Pluggenes posisjon - Położenie korków - Poloha zátek - Poloha zátok - Sapkák elhelyezkedése - Položaj čepov - Poziția dopurilor - Положение на тапите - Tapa konumu - Положення кришок - وضع السدادات

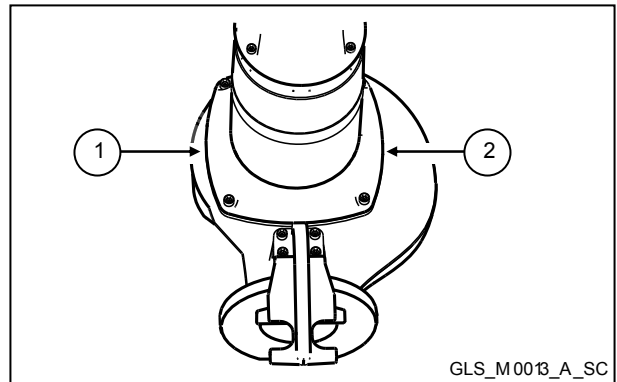

Svuotare l'olio - Draining the oil - Vidanger l'huile - Das Öl entleeren - Vaciar el aceite - Esvaziar o óleo - Olie aftappen - Tõmma ut oljan - Valuta õljy ulos - Слить масло - Αδειάστε το λάδι - Tøm olien - Tøm ut oljen - Odprowadzić olej - Vypuštění oleje - Vypustenie oleja - Üritse le az olajat - Izpraznite olje - Evacuarea uleiului - Изпразнете маслото - Yağı boşaltın - Випустіть мастило - تفريغ الزيت

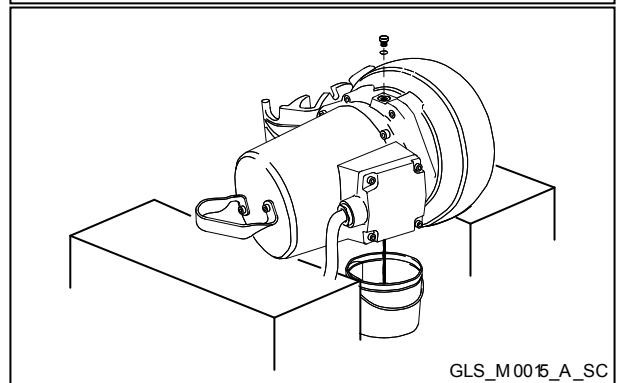
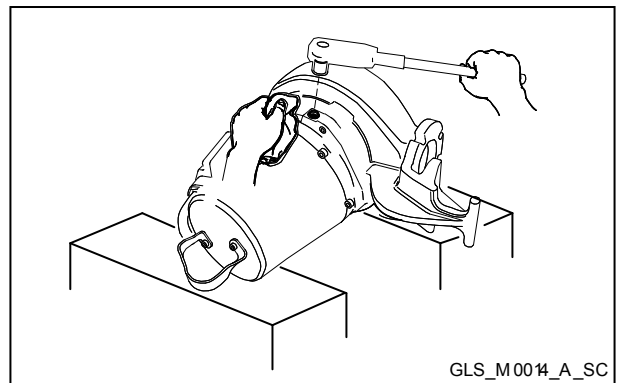
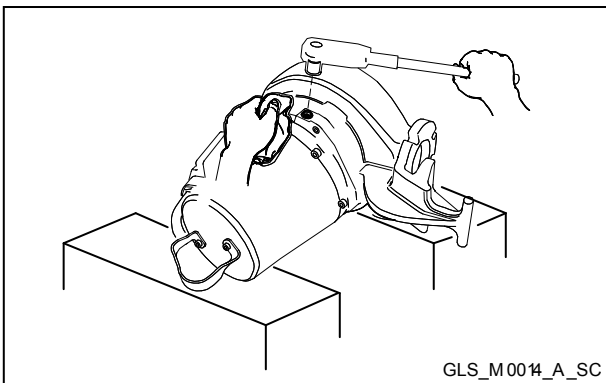

Riempire con olio - Fill with oil - Verser l'huile - Mit Öl befüllen - Llenar con aceite - Encher com óleo - Met olie vullen - Fylla på med olja - Täytä öljyllä - Заполнить маслом - Γεμίστε με λάδι - Põfyld olie - Põfyll olje - Napelnić olejem - Naplnění olejem - Doplnenie oleja - Töltse meg olajjal - Nalijte olje - Umplerea cu ulei - Напълнете маслото - Yağ ile doldurun - Залийте мастило - ملء الزيت

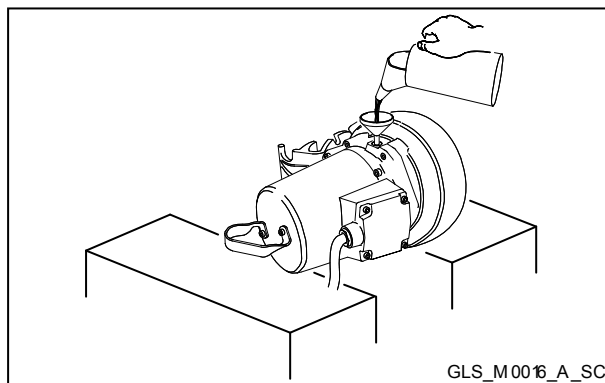

GLS_M0016_A_SC

10.13 Sezionate (versione base) - Cross section (basic version) - Coupes (version de base) - Getrennt (Basisversion) - Seccionadas (versión de base) - Secções (versão base) - Doorsneden (basismodel) - Planritning (basversionen) - Poikkileikkaukset (perusversio) - Сечение (базовая модель) - Διαμερισμένες (βασική έκδοση) - Tværsnit (standard version) - Tverrsnitt (standardutgave) - Sekcje (wersja podstawowa) - Pohled na čerpadla v řezu (základní verze) - Pohľad na čerpadlo v reze (základná verzia) - Keresztmetszet (alap változat) - Prerez (osnovna različica) - Secțiuni (varianta de bază) - Схема на напречно сечение - Parça şeması (temel versiyon) - Січення (базова модель) - الفحص بدقة (النوع المعياري)

GLV 50-12-251-S/P
 GLS/V 50-15-251-S/P
 GLS/V 50-16-253-S/P
 GLS/V 50-20-253-S/P
 GLS/V 50-24-253-S/P

GLS 65-15-251
 GLS 65-16-253
 GLS/V 65-20-253
 GLS/V 65-24-253

GLS/V 65-32-253
 GLS/V 65-42-253
 GLS/V 80-32-253
 GLS/V 80-42-253
 GLS/V 80-59-253
 GLS/V 80-74-253

GLS/V 100-24-452
 GLS/V 100-31-453
 GLS/V 100-45-453
 GLS/V 100-59-453

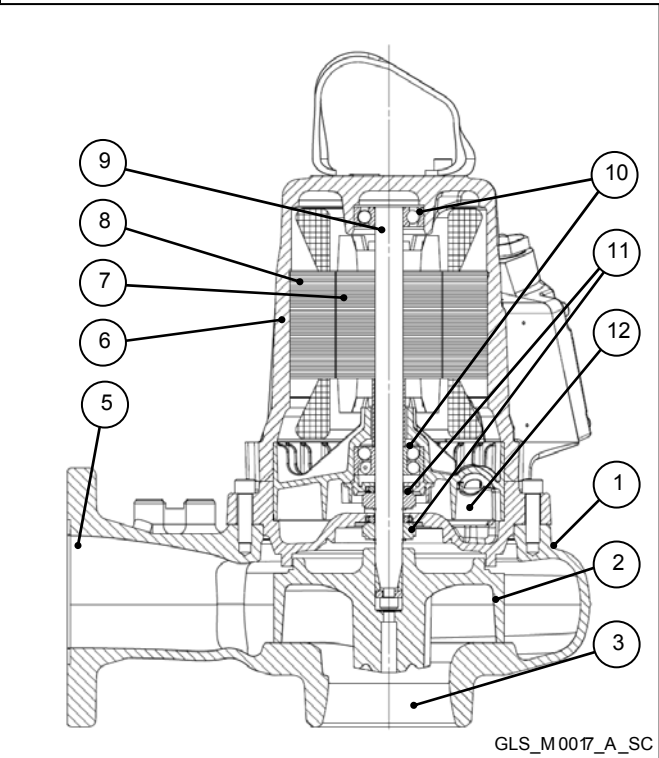
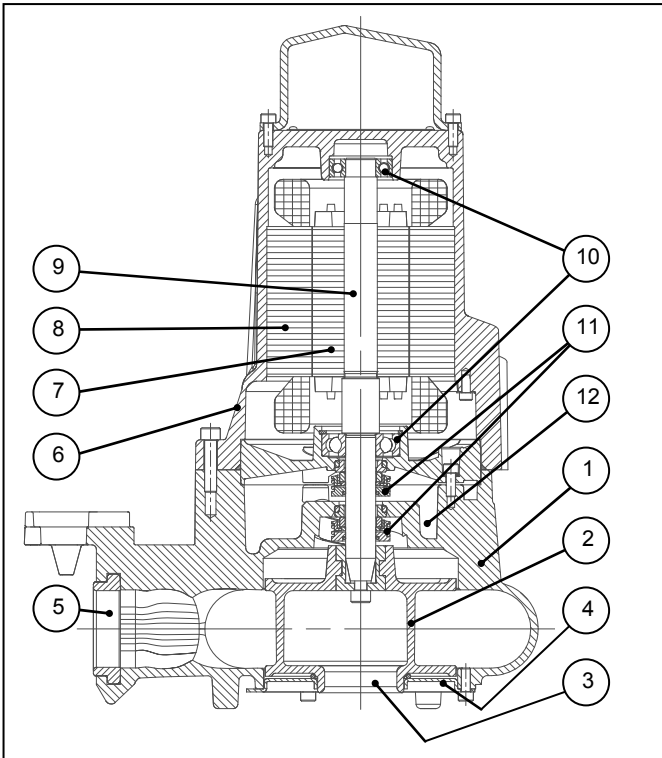

GLS_M0017_A_SC

1	Corpo pompa
2	Girante
3	Bocca d'aspirazione
4	Coperchio aspirazione
5	Bocca di mandata
6	Cassa motore
7	Rotore
8	Statore
9	Albero
10	Cuscinetti
11	Tenuta meccanica
12	Camera dell'olio

1	Pump casing
2	Impeller
3	Suction port
4	Suction cover
5	Delivery port
6	Motor casing
7	Rotor
8	Stator
9	Shaft
10	Bearings
11	Mechanical seal
12	Oil chamber

1	Corps de pompe
2	Roue
3	Orifice d'aspiration
4	Couvercle d'aspiration
5	Orifice de refoulement
6	Carcasse moteur
7	Rotor
8	Stator
9	Arbre
10	Roulements
11	Garniture mécanique
12	Chambre à huile

1	Pumpengehäuse
2	Laufrad
3	Ansaugöffnung
4	Deckel Ansaugung
5	Ausflussöffnung
6	Motorgehäuse
7	Rotor
8	Stator
9	Welle
10	Lager
11	Gleitringdichtung
12	Ölkammer

1	Caja bomba
2	Rodete
3	Boca de aspiración
4	Tapa de aspiración
5	Boca de impulsión
6	Caja motor
7	Rotor
8	Estator
9	Eje
10	Cojinetes
11	Sello mecánico
12	Cámara del aceite

1	Pomplichaam
2	Waaier
3	Aanzuigopening
4	Aanzuigkap
5	Persopening
6	Motorhuis
7	Rotor
8	Stator
9	As
10	Lagers
11	Mechanische asafdichting
12	Oliekamer

1	Pumpun runko
2	Juoksupyörä
3	Imuaukko
4	Imukansi
5	Poistoaukko
6	Moottorin kotelo
7	Roottori
8	Staattori
9	Akseli
10	Laakerit
11	Mekaaninen tiiviste
12	Öljykammio

1	Σώμα αντλίας
2	Περωτή
3	Στόμιο αναρρόφησης
4	Καπάκι αναρρόφησης
5	Στόμιο παροχής
6	Κιβώτιο κινητήρα
7	Ρότορας
8	Στάτορας
9	Άξονας
10	Κουζινέτα
11	Μηχανική στεγανοποίηση
12	Θάλαμος του λαδιού

1	Pumpehus
2	Pumpehjul
3	Sugestuss
4	Sugedeksel
5	Trykkstuss
6	Motorhus
7	Rotor
8	Stator
9	Aksel
10	Lager
11	Mekanisk tetning
12	Oljekammer

1	Tělo čerpadla
2	Oběžné kolo

1	Corpo da bomba
2	Impulsor
3	Boca de aspiração
4	Tampa de aspiração
5	Boca de compressão
6	Caixa motor
7	Rotor
8	Estator
9	Veio
10	Rolamentos
11	Vedante mecânico
12	Câmara do óleo

1	Pumphus
2	Pumphjul
3	Sugmunstycke
4	Sugkåpa
5	Tryckutlopp
6	Motorlåda
7	Rotor
8	Stator
9	Axel
10	Lager
11	Mekanisk tätning
12	Oljebad

1	Корпус насоса
2	Крыльчатка
3	Устье всасывания
4	Крышка всасывания
5	Устье подачи
6	Корпус двигателя
7	Ротор
8	Статор
9	Вал
10	Подшипники
11	Механическая прокладка
12	Камера масла

1	Pumpehus
2	Pumpehjul
3	Indsugningsstuds
4	Dæksel ved indsugning
5	Trykstuds
6	Motorhus
7	Rotor
8	Stator
9	Aksel
10	Lejer
11	Mekanisk pakning
12	Oliekammer

1	Korpus pompy
2	Wirnik
3	Otwór ssawny
4	Pokrywka ssawna
5	Otwór doprowadzający
6	Obudowa silnika
7	Rotor
8	Stojan
9	Wał
10	Łożyska
11	Uszczelnienie mechaniczne
12	Komora oleju

1	Telo čerpadla
2	Obežné koleso

3	Sací otvor
4	Sací kryt
5	Přívodní otvor
6	Skříň motoru
7	Rotor
8	Stator
9	Hřídel
10	Ložiska
11	Mechanická ucpávka
12	Olejová komora

1	Szivattyútest
2	Járókerék
3	Szivónylás
4	Szívás fedél
5	Odairányú nyílás
6	Motorszekrény
7	Forgórész
8	Állórész
9	Tengely
10	Csapágyak
11	Mechanikus tömítés
12	Olajkamra

1	Corp pompă
2	Rotor cu palete
3	Gură de aspirație
4	Capac aspirație
5	Gură de refulare
6	Carcasă motor
7	Rotor
8	Stator
9	Arbore
10	Lagăre
11	Etanșare mecanică
12	Cameră ulei

1	Pompa gövdesi
2	Fan
3	Emme ağızı
4	Emme borusu kapağı
5	Basma ağızı
6	Motor dairesi
7	Rotor
8	Stator
9	Mil
10	Rulmanlar
11	Mekanik salmastra
12	Yağ odası

1	جسم المضخة
2	الوحدة الدوارة
3	فتحة الشفط
4	غطاء الشفط
5	فتحة التدفق الخارج
6	علبة المحرك
7	الدوار
8	الجزء الثابت
9	عمود الدوران
10	كرليات التحميل (رولمان البلى)
11	سدادة ميكانيكية
12	غرفة الزيت

3	Nasávací otvor
4	Nasávací kryt
5	Prívodný otvor
6	Skriňa motora
7	Rotor
8	Stator
9	Hriadeľ
10	Ložiská
11	Mechanická upchávka
12	Olejová komora

1	Ohišje črpalke
2	Rotor
3	Sesalna odprtina
4	Pokrov sesalnega dela
5	Tlačna odprtina
6	Ohišje motorja
7	Rotor
8	Stator
9	Gred
10	Ležaji
11	Mehanska zapora
12	Oljna komora

1	Тяло на помпата
2	Витло
3	Аспираторен отвор
4	Аспираторен капак
5	Отходен отвор
6	Каса на мотора
7	Ротор
8	Статор
9	Вал
10	Уплътнения
11	Механична изолация
12	Камера за маслото

1	Корпус насоса
2	Крильчатка
3	Отвір всмоктування
4	Кришка всмоктування
5	Отвір подачі
6	Корпус двигуна
7	Ротор
8	Статор
9	Вал
10	Підшипники
11	Механічна прокладка
12	Камера мастила

AUSTRALIAN DISTRIBUTOR



CALL 1300 789 466

When Pump Knowledge Matters

www.kelairpumps.com.au

Headquarters

LOWARA S.r.l. UNIPERSONALE

Via Lombardi 14

36075 Montecchio Maggiore - Vicenza - Italy

Tel. (+39) 0444 707111 - Fax (+39) 0444 492166

e-mail: lowara.mkt@itt.com

web: www.lowara.com

Lowara reserves the right to make modifications without prior notice.

Engineered for life