



AUSTRALIAN DISTRIBUTOR



CALL 1300 789 466  
When Pump Knowledge Matters  
[www.kelairpumps.com.au](http://www.kelairpumps.com.au)

## Serial Data Transfer - RS485

---

# HYDROVAR®

## Modbus – Protocol

for HV 2.015 /2.022  
HV 4.022 / 4.030 /4.040  
HV 4.055 / 4.075 / 4.110

Software Version: V01.1 (or higher)

*Engineered for life*





**INDEX**

**1 A Few Facts about the Modbus Protocol .....4**

1.1 Communication.....4

1.2 Broadcasting .....4

1.3 Data Protection .....4

1.4 Transmission Mode .....5

1.5 Function Codes.....6

**2 Wiring and Connections.....8**

2.1 Between HYDROVAR and external User.....8

2.2 Multi-pump application with External User.....9

**3 HYDROVAR Settings .....10**

**4 Index list HYDROVAR Master Inverter – SW version V01.1 .....11**

**5 Description of Individual Parameters of the HYDROVAR.....19**

5.1 Note H1: Status Units (INDEX = 90 DEZ / 5A HEX).....19

5.2 Note H2: Status Device (INDEX = 303 DEZ / 12F HEX).....20

5.3 Note H3: Errors (INDEX = 302 DEZ / 12E HEX).....21



**6 Examples .....22**

6.1 Start of all connected Pumps (using Broadcast Function) .....22

6.2 Set Minimum Frequency on a Basic Inverter to 25Hz .....23

6.3 Request Actual Frequency .....25

**7 Notes:.....26**

	<p><b>Read and follow the operating instructions and safety instructions carefully before starting operations! All modifications must be done by qualified technicians!</b></p>	
-------------------------------------------------------------------------------------	---------------------------------------------------------------------------------------------------------------------------------------------------------------------------------	---------------------------------------------------------------------------------------



## 1 A Few Facts about the Modbus Protocol



**NOTE: The Modbus Protocol is an international standardized Bus Protocol!**  
The general information within this IOM is just a brief overview, for detailed information please use the Modbus Protocol reference guide, or any other source of information (e.g. available on web)

This protocol defines a message structure that controllers will recognize and use, regardless of the type of networks over which they communicate. It describes the process a controller uses to request access to another device, how it will respond to requests from the other devices, and how errors will be detected and reported. It establishes a common format for the layout and contents of message fields.

During communications on a Modbus network, the protocol determines how each controller will know its device address, recognize a message addressed to it, determine the kind of action to be taken, and extract any data or other information contained in the message.

### 1.1 Communication

The HYDROVAR uses the RS485 serial interface that defines connect pinouts, cabling, signal levels, transmission baud rates and parity checking.

Controllers communicate using a master-slave technique, in which only the master can start a transfer or polling. The other devices (Slaves) respond by supplying the requested data to the master, or by taking the action requested in the query.

The Master can address individual slaves, or can initiate a broadcast message to all slaves.

### 1.2 Broadcasting

Using the BROADCAST function it is possible to write to (WRITE-only) all converters (SLAVE) from the MASTER simultaneously. This means that when changing the setting from Fmax to 60 Hz it is not necessary to address all converters (SLAVE) individually using the appropriate address (set SIO address on the converter). Instead the BROADCAST function (WRITE only) can be used. Therefore you have to write the appropriate data to SIO address 0.

### 1.3 Data Protection

Standard Modbus serial networks use two kinds of error checking:

- Parity checking (even or odd) can be optionally applied to each character.
- Frame checking (LRC or CRC) is applied to the entire message.

Both the character check and message frame check are generated in the master device and applied to the message contents before transmission. The slave device checks each character and the entire message frame during receipt.

**Detailed information you will find in the Modbus Protocol Reference Guide!**

---



## 1.4 Transmission Mode

When using the Modbus Protocol you have to choose between two transmission Modes: ASCII or RTU  
The different modes determine how information will be packed into the message fields and decoded.

As user you have to select the desired mode, along with the serial port communication parameters (baud rate, parity mode...).

**! The mode and serial parameters must be the same for all devices on the Modbus network!**

**The following modes can be selected and are supported by the HYDROVAR:**

RTU N81	1 start bit, 8 data bits, 1 stop bit, No parity
RTU N82	1 start bit, 8 data bits, 2 stop bits, No parity
RTU E81	1 start bit, 8 data bits, 1 stop bit, Even parity
RTU O81	1 start bit, 8 data bits, 1 stop bit, Odd parity
ASCII N72	1 start bit, 7 data bits, 2 stop bits, No parity
ASCII E71	1 start bit, 7 data bits, 1 stop bit, Even parity
ASCII O71	1 start bit, 7 data bits, 1 stop bit, Odd parity



## 1.5 Function Codes

### 03 Read Holding Registers – READ COMMAND

Read the binary contents of holding registers in the slave! Broadcast is not supported!

**Note:** The Modbus Registers are addressed starting at zero!  
E.g. Address 33 has to be addressed as 32

#### Example: Read the Actual Value

##### QUERY

	HEX	
Slave Address	01	Could be set on the HYDROVAR via Parameter ADDRESS [1205]
Function	03	Read Holding Register
Starting Address High	00	
Starting Address Low	32	Modbus Index 33 (HEX) – Actual value has to be addressed
No. of Points High	00	To read more than one holding register is not supported by the
No. of Points Low	01	HYDROVAR.
Error Check CRC-High	25	
Error Check CRC-Low	C5	Generated CRC-Checksum

##### RESPONSE

	HEX	
Slave Address:	01	
Function	03	
Byte Count	02	
Data High	02	
Data Low	08	=> 208 HEX = 520 DEZ => Actual Value = 5.20 bar
Error Check CRC-High	76	
Error Check CRC-Low	B8	Generated CRC-Checksum



## 06 Preset Single Register – WRITE COMMAND

Preset a value into a single holding register.

When broadcast function is used, the function presets the same register reference in all connected slaves.

**Note:** The Modbus Registers are addressed starting at zero!  
E.g. Address E9 has to be addressed as E8

### Example: Set the Required Value 1 to 3.50 bar

#### QUERY

	HEX	
Slave Address	01	Could be set on the HYDROVAR via Parameter ADDRESS [1205]
Function	06	Preset Single Register
Register Address High	00	
Register Address Low	E8	Modbus Index E9 (HEX) – Req. Value 1 has to be addressed
Preset Data High	01	
Preset Data Low	5E	=> 15E HEX = 350 DEZ => sets the Required Value 1 to 3.50 bar
Error Check CRC-High	89	
Error Check CRC-Low	96	Generated CRC-Checksum

#### RESPONSE

	HEX	
Slave Address:	01	
Function	06	
Register Address High	00	
Register Address Low	E8	
Preset Data High	01	
Preset Data Low	5E	=> Required Value 1 is set to 3.50 bar
Error Check CRC-High	89	
Error Check CRC-Low	96	Generated CRC-Checksum



## 2 Wiring and Connections

### 2.1 Between HYDROVAR and external User



**NOTE:**  
For detailed information regarding installation, wiring and configuration of the HYDROVAR, please read and follow the operation instruction of the HYDROVAR itself!



All installations and maintenance have to be performed by properly trained and qualified personal with proper tools!!

- Remove the screws holding the top cover and lift off the top cover.
- The RS485 terminals which could be used for the communication with an external-control-device via standardized Modbus-protocol are placed on the Control Card at the HYDROVAR Master Inverter. (see picture below)

e.g. shown on a HV 4.040

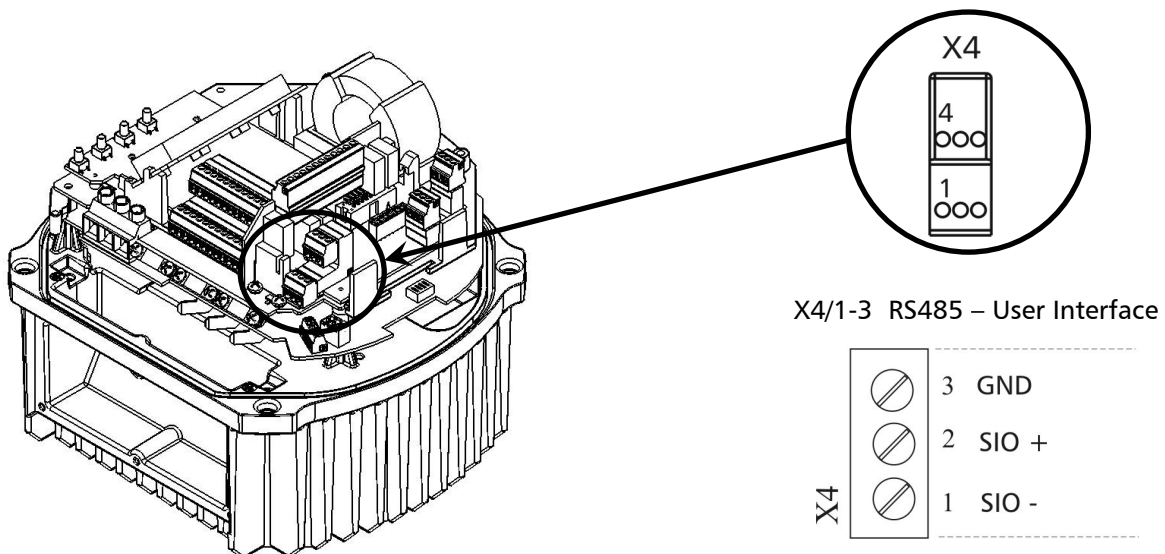

#### Connection examples:

Wiring between HYDROVAR and any external device:  
e.g. wiring to a PC

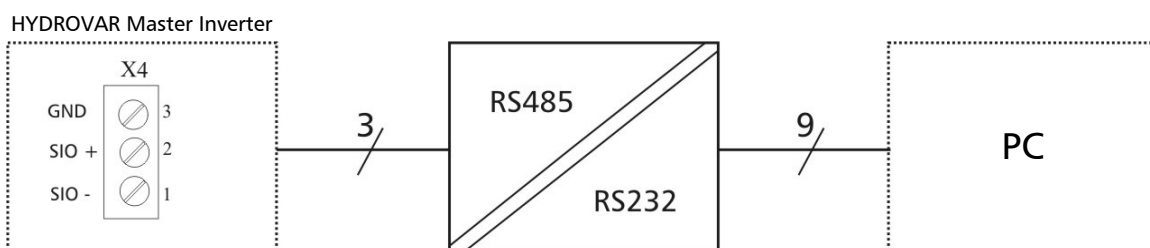



e.g. wiring to a PLC (Programmable Logic Controller)

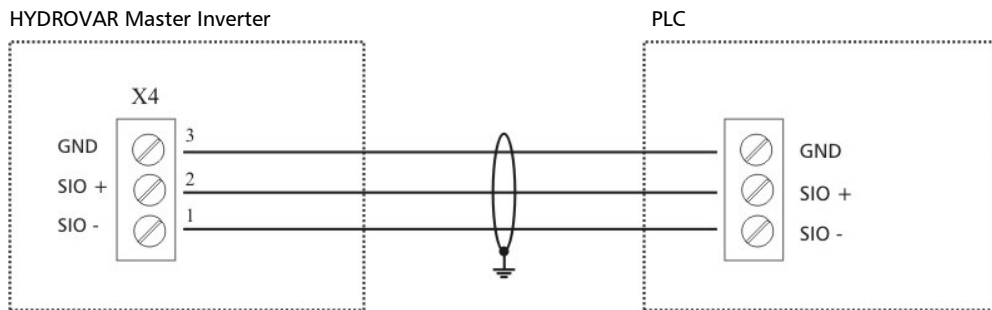

## 2.2 Multi-pump application with External User

When using a Multi- pump application you have to wire the user-interface **and** the internal interface between all used Master Inverters in the Group!

e.g. 2 Master and 2 Basic Inverters

### Connection of the internal interface:

You have to connect the internal interface on all used units in the group, even the Master and the Basic Inverters.

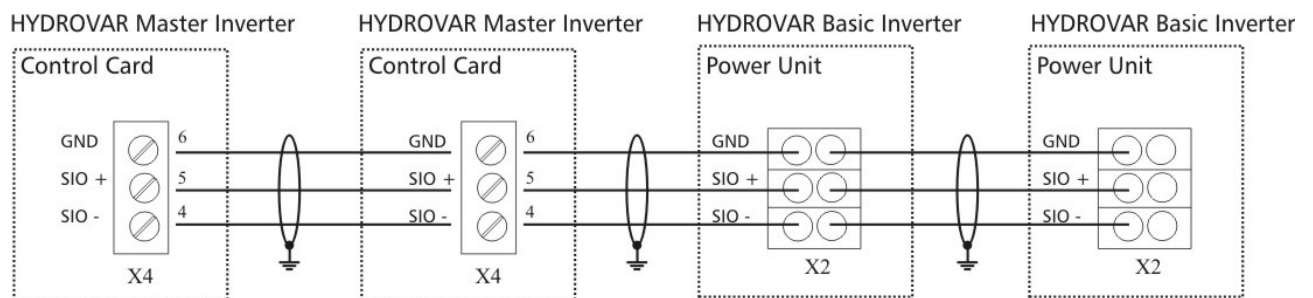

### Connection of the user interface:

The connection of the User Interface has to be done between each Master Inverter. The connection from the pump group to any external device can be made on each inverter!

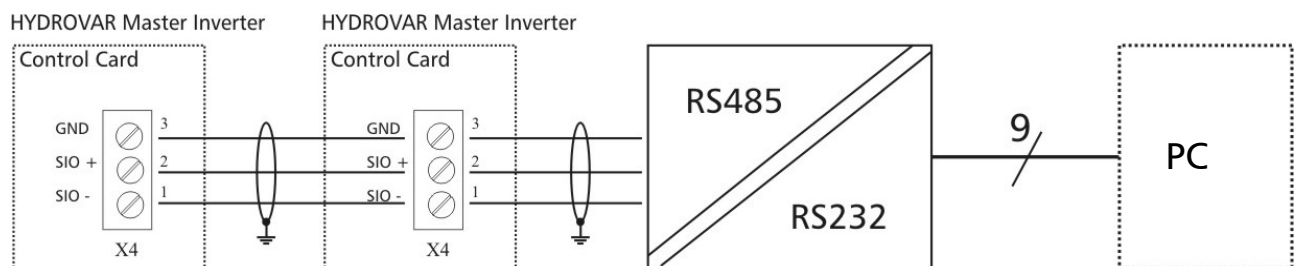



### 3 HYDROVAR Settings

The following 3 parameters which define the user interface on the HYDROVAR have to be set on each Master Inverter to guarantee correct Modbus communication.

<b>1205</b>	<b>1205 ADDRESS</b> 1	Set desired Address for the User Interface
-------------	--------------------------	--------------------------------------------

Possible settings: 1 - 247

Valid Modbus Address for the User Interface could be set between 1 and 247. Each Master Inverter must be allocated its own address!

<b>1210</b>	<b>1210 BAUDRATE</b> 9600	Baudrate for User Interface
-------------	------------------------------	-----------------------------

Possible settings: 1200, 2400, 4800, 9600, 14400, 19200, 38400

<b>1215</b>	<b>1215 FORMAT</b> RTU N81	Format for User Interface
-------------	-------------------------------	---------------------------

Possible settings: RTU N81, RTU N82, RTU E81, RTU O81, ASCII N72, ASCII E71, ASCII 071

The serial port communication parameters Baud rate and Format could be chosen with the above parameters and must be the same for all devices on the Modbus network.



## 4 Index list HYDROVAR Master Inverter – SW version V01.1

Modbus INDEX HEX	Modbus INDEX DEC.	Function	Menu - Index	DESCRIPTION	RANGE (DECIMAL)
32	50	06		Start / Stop of the Inverter	0 = STOP    1 = ON
33	51	03		Actual Value	0-10000
35	52	03		Actual frequency	0 – 70.0 Hz    0 – 700 (in 1/10 Hz steps)
38	56	03	03	Eff. Required Value	0-10000
39	57	03,06	04	Start Value	0-99%; OFF    0-100    -> 100=OFF
3A	58	03,06	05	Language	0 = English 1 = German    3 = French    5 = Portuguese 2 = Italian    4 = Dutch    6 = Spain
3B	59	03		Read Date - Day	01-31
3C	60	03		Read Date - Month	01-12
3D	61	03		Read Date - Year	2000-2099    00-99
3E	62	06		Set Date - Day	01-31
3F	63	06		Set Date - Month	01-12
40	64	06		Set Date - Year	2000-2099    00-99
41	65	03		Read Time - Hours	00-23
42	66	03		Read Time - Minutes	00-59
43	67	03		Read Time – Seconds	00-59
44	68	06		Set Time – Hours	00-23
45	69	06		Set Time – Minutes	00-59
46	70	06		Set Time – Seconds	00-59
47	71	03,06	08	Auto-Start	0 = OFF    1 = ON
48	72	03		Operation Time – Hours_High	00000-99999
49	73	03		Operation Time – Hours_Low	00000-99999
4A	74	03		Operation Time - Minutes	0-59



Modbus INDEX HEX	Modbus INDEX DEC.	Function	Menu - Index	DESCRIPTION	RANGE	
5A	90	03	21	Status Units		See NOTE H1 (PAGE 19)
6A	106	03,06	22	Select Device	1-8	1-8
5D	93	03,06		Enable Device – Motor relay 1		0 = disabled 1 = enabled
5E	94	03,06		Enable Device – Motor relay 2		0 = disabled 1 = enabled
5F	95	03,06		Enable Device – Motor relay 3		0 = disabled 1 = enabled
60	96	03,06		Enable Device – Motor relay 4		0 = disabled 1 = enabled
61	97	03,06		Enable Device – Motor relay 5		0 = disabled 1 = enabled
62	98	03,06		Enable Device – Device 1		0 = disabled 1 = enabled
63	99	03,06		Enable Device – Device 2		0 = disabled 1 = enabled
64	100	03,06		Enable Device – Device 3		0 = disabled 1 = enabled
65	101	03,06		Enable Device – Device 4		0 = disabled 1 = enabled
66	102	03,06		Enable Device – Device 5		0 = disabled 1 = enabled
67	103	03,06		Enable Device – Device 6		0 = disabled 1 = enabled
68	104	03,06		Enable Device – Device 7		0 = disabled 1 = enabled
69	105	03,06		Enable Device – Device 8		0 = disabled 1 = enabled



**ITT**

**HYDROVAR®**

Modbus INDEX HEX	Modbus INDEX DEC.	Function	Menu - Index	DESCRIPTION	RANGE
82	130	03		Production Date – Day	1-31
83	131	03		Production Date – Month	1-12
84	132	03		Production Date – Year	0-99
85	133	03,06	42	Select Inverter	1-8
86	134	03		Temperature Inverter – Degrees	10-100°C
87	135	03		Temperature Inverter – Percent	0- 100%
88	136	03	44	Current Inverter	0-100%
89	137	03	45	Voltage Inverter	0-750V
8C	140	03,06	0105	Mode	0 = Controller 1 = Cascade Relay 2 = Cascade Serial 3 = Actuator
8D	141	03	0110	Set Password	0-9999
8E	142	03,06	0115	Lock Function	0= OFF    1= ON
8F	143	03,06	0120	Display Contrast	10-100%
90	144	03,06	0125	Display Brightness	10-100%

*Engineered for life*



# ITT

# HYDROVAR®

Modbus INDEX HEX	Modbus INDEX DEC.	Function	Menu - Index	DESCRIPTION	RANGE	
96	150	03,06	0205	Max. Units		1-8
97	151	03,06	0210	Inverter		0 = ALL; 1 - 8
98	152	03,06	0215	Ramp 1	1 – 250 sec	1-250
99	153	03,06	0220	Ramp 2	1 – 250 sec	1-250
9A	154	03,06	0225	Ramp 3	1 – 250 sec	1-250
9B	155	03,06	0230	Ramp 4	1 – 250 sec	1-250
9C	156	03,06	0235	Ramp Fmin A	1.0 – 25.0 sec	10 – 250
9D	157	03,06	0240	Ramp Fmin D	1.0 – 25.0 sec	10 – 250
9E	158	03,06	0245	Max. Frequency	30 – 70.0 Hz	300 – 700
9F	159	03,06	0250	Min. Frequency	0 – 30.0 Hz.	0 – 300
A0	160	03,06	0255	Config. Fmin		0: f->0    1: f->fmin
A1	161	03,06	0260	Fmin Time	0-100 sec	0-100
A2	162	03,06	0265	Boost	0 – 25%	0 – 25
A3	163	03,06	0270	Knee Frequency	30.0 – 70.0 Hz	300 – 700
A4	164	03,06	0275	Power Reduction		0 = OFF    2 = 75% 1 = 85%    3 = 50%
A5	165	03,06	0280	Sel. Switching Frequency		0 = Auto 1 = 4kHz    2 = 8kHz
AB	171	03,06	0310	Window	0 – 100%	0 – 100
AC	172	03,06	0315	Hysteresis	0 – 100%	0 – 100
AD	173	03,06	0320	Regulation Mode		0 = normal    1 = invers
AE	174	03,06	0325	Frequency Lift	0-70.0 Hz	0-700
AF	175	03,06	0330	Lift Amount	0.0-200.0 %	0-2000

*Engineered for life*



# ITT

# HYDROVAR®

Modbus INDEX HEX	Modbus INDEX DEC.	Function	Menu - Index	DESCRIPTION	RANGE			
B4	180	03,06	0405	Dimension Unit	0 = bar 1 = psi 2 = m <sup>3</sup> /h 3 = g/min 4 = m/H <sub>2</sub> O	5 = ft 6 = °C 7 = °F 8 = l/sec 9 = l/min	10 = m/sec 11 = ... 12 = %	
B5	181	03,06	0410	Config. Sensor		0 = Sensor 1 1 = Sensor 2 2 = Auto	3 = Switch Dig1 4 = Switch Dig2 5 = Switch Dig3 6 = Switch Dig4	7 = Auto Lower 8 = Auto Higher 9 = Sens.1 – Sens.2
B6	182	03,06	0415	Sensor Type		0 = analog U 0-10V 1 = analog I 0-20mA 2 = analog I 4-20mA		
B7	183	03,06	0420	Sensor Range		0-10000		
B8	184	03,06	0425	Sensor Curve		0=Linear    1=Qadratic		
B9	185	03,06	0430	Sensor 1 Cal. 0	-10% .. +10%	-10..10		
BA	186	03,06	0435	Sensor 1 Cal. X	-10% .. +10%	-10..10		
BB	187	03,06	0440	Sensor 2 Cal. 0	-10% .. +10%	-10..10		
BC	188	03,06	0445	Sensor 2 Cal. X	-10% .. +10%	-10..10		

*Engineered for life*



# ITT

# HYDROVAR®

Modbus INDEX HEX	Modbus INDEX DEC.	Function	Menu - Index	DESCRIPTION	RANGE	
BE	190	03,06	0505	Actual Value Increase	0-Sensor Range	0 - 10000
BF	191	03,06	0510	Actual Value Decrease	0-Sensor Range	0 - 10000
C0	192	03,06	0515	Enable Frequency	0.0-70.0 Hz	0-700
C1	193	03,06	0520	Enable Delay	0-100 sec	0-100
C2	194	03,06	0525	Switch Delay	0-100 sec	0-100
C3	195	03,06	0530	Disable Frequency	0.0- 70.0Hz	0-700
C4	196	03,06	0535	Disable Delay	0-100 sec	0-100
C5	197	03,06	0540	Drop Frequency	0.0- 70.0Hz	0-700
C6	198	03,06	0545	Overvalue	OFF-Sens. Range	0-1000
C7	199	03,06	0550	Overvalue Delay	0.0- 10.0sec	0-100
C8	200	03,06	0555	Switch Interval	0-250 h	0-250
C9	201	03,06	0560	Synchron Limit	0.0-max. Freq.	0-700
CA	202	03,06	0565	Synchron Window	0.0-10.0%	0-100
CB	203	03,06	0570	Master Priority		0 = OFF 1 = ON
D2	210	03,06	0605	Minimum Threshold Limit	0-Sensor Range	0 - 10000
D3	211	03,06	0610	Delay Time	0-100 sec	0-100
D4	212	03,06	0615	Error Reset		0 = OFF 1 = ON
DC	220	03,06	0705	Analog out 1		0 = Actual Value      1 = Output Frequency
DD	221	03,06	0710	Analog out 2		0 = Actual Value      1 = Output Frequency
DE	222	03,06	0715	Config. Relay 1		0 = Power      2 = Errors      4 = Standby 1 = Running    3 = Warnings    5 = Errorresets
DF	223	03,06	0720	Config. Relay 2		0 = Power      2 = Errors      4 = Standby 1 = Running    3 = Warnings    5 = Errorresets

*Engineered for life*



Modbus INDEX HEX	Modbus INDEX DEC.	Function	Menu - Index	DESCRIPTION	RANGE
E6	230	03,06	0805	Config. Required Value 1	0 = digital 1 = analog U 0-10V 2 = analog I 0-20mA 3 = analog I 4-20mA
E7	231	03,06	0810	Config. Required Value 2	0 = OFF 1 = digital 2 = analog U 0-10V 3 = analog I 0-20mA 4 = analog I 4-20mA
E8	232	03,06	0815	Switch Required Value	0 = Setpoint 1 1 = Setpoint 2 2 = Switch Dig1 3 = Switch Dig2 4 = Switch Dig3 5 = Switch Dig4
E9	233	03,06	0820	Required Value 1	0-Sensor Range 0 - 10000
EA	234	03,06	0825	Required Value 2	0-Sensor Range 0 - 10000
EB	235	03,06	0830	Actuator Frequency 1	Min Frequency - Max. Frequency
EC	236	03,06	0835	Actuator Frequency 2	Min Frequency - Max. Frequency
104	260	06	1125	Clear Errors	0 = Clear Errors of all HV 1 = Clear Errors of HV#1 2 = Clear Errors of HV#2 3 = Clear Errors of HV#3 4 = Clear Errors of HV#4 5 = Clear Errors of HV#5 6 = Clear Errors of HV#6 7 = Clear Errors of HV#7 8 = Clear Errors of HV#8
105	261	06	1130	Clear Motorhours	0 = Reset Motor hours of all HV 1 = Reset Motor of HV#1 2 = Reset Motor of HV#2 3 = Reset Motor of HV#3 4 = Reset Motor of HV#4 5 = Reset Motor of HV#5 6 = Reset Motor of HV#6 7 = Reset Motor of HV#7 8 = Reset Motor of HV#8
			1135	Clear Operation Time	Look at Index 300 DEC. PROGNO!



Modbus INDEX HEX	Modbus INDEX DEC.	Function	Menu - Index	DESCRIPTION	RANGE
10E	270	03,06	1205	Address	1-247
10F	271	03,06	1210	Baudrate	1 = 1200      4 = 9600      7 = 38400 2 = 2400      5 = 14400 3 = 4800      6 = 19200
110	272	03,06	1215	Format	0 = RTU N81      3 = RTU O81      6 = ASCII O71 1 = RTU N82      4 = ASCII N72 2 = RTU E81      5 = ASCII E71
111	273	03,06	1220	Pump Address	1-8
12C	300	03,06		PROGNO (CMD Macro)	1 = Performs a Restart of the Interp. Communication 2 = Switch of the Slave and Master origin pump 5 = Software Reboot 10 = Loads Defaultset 1 11 = Loads Defaultset 2 250 = Clear the Operation Time 251 = Reset the Errors form Stand alone Basic
12D	301	03		Software	11 = Software Version V01.1
12E	302	03		Errors	See NOTE H3 (PAGE 21)
12F	303	03		Status Device	See NOTE H2 (PAGE 20)



## 5 Description of Individual Parameters of the HYDROVAR

### 5.1 Note H1: Status Units (INDEX = 90 DEZ / 5A HEX)

Using this index you will get a quick overview beyond the status of the connected units. The Indication depends also on the selected Mode.

**This information is just available for the function 03 Read Holding Registers!**  
(It isn't possible to write information to this index!)

- In **Cascade Serial** mode the status of all (max. 8) connected units is shown (whereas 1=activated / 0=deactivated)
- In **Cascade Relay** mode (Master is fitted with additional relay card) the status of the 5 Relay-switching contacts is shown.

Cascade Serial			
BIT0	Unit 8	1: Unit is running	0: Unit is stopped
BIT1	Unit 7	1: Unit is running	0: Unit is stopped
BIT2	Unit 6	1: Unit is running	0: Unit is stopped
BIT3	Unit 5	1: Unit is running	0: Unit is stopped
BIT4	Unit 4	1: Unit is running	0: Unit is stopped
BIT5	Unit 3	1: Unit is running	0: Unit is stopped
BIT6	Unit 2	1: Unit is running	0: Unit is stopped
BIT7	Unit 1	1: Unit is running	0: Unit is stopped

Cascade Relay			
BIT0	Relay Contact 5	1: Relay Contact closed	0: Relay Contact opened
BIT1	Relay Contact 4	1: Relay Contact closed	0: Relay Contact opened
BIT2	Relay Contact 3	1: Relay Contact closed	0: Relay Contact opened
BIT3	Relay Contact 2	1: Relay Contact closed	0: Relay Contact opened
BIT4	Relay Contact 1	1: Relay Contact closed	0: Relay Contact opened
BIT5	-	Not used!	
BIT6	-	Not used!	
BIT7	-	Not used!	

As response you will receive the current Status as Binary Decoded value.  
e.g.: Cascade Relay Mode – Unit 1 and 3 are running

**RESPONSE:**

Preset Data High	HEX		
	00		
Preset Data Low	A0	=> BIN = 00010100	=> Unit 1 and 3 are running



## 5.2 Note H2: Status Device (INDEX = 303 DEZ / 12F HEX)

### Status of "THIS" Control Card

Show the individual Status of the addressed Control card.

**This information is just available for the Function 03 Read Holding Registers!**  
(It isn't possible to write information to this index!)

DAT-L	
BIT1	Reserved (for internal use)
BIT2	1: External ON/OFF (Release Terminal) = ON 0: External ON/OFF (Release Terminal) = OFF
BIT3	1: Key-Enable from Menu = ON 0: Key-Enable from Menu = OFF
BIT4	1: Control Card is in ERROR
BIT5	1: Control Card is in Warning
BIT6	Reserved (for internal use)
BIT7	Reserved (for internal use)
BIT8	Reserved (for internal use)

As response you will receive the current Status as Binary Decoded value.  
e.g.: HYDROVAR is stopped because the external release (X3/7-8) is open.

### RESPONSE:

	HEX		
Preset Data High	00		
Preset Data Low	04	=> BIN = 00000100	=> External Release = OFF



5.3 Note H3: Errors (INDEX = 302 DEZ / 12E HEX)

All errors which could occur on the HYDROVAR could be indicated via the below binary decoded Index!

**This information is just available for the Function 03 Read Holding Registers!**  
(It isn't possible to write information to this index!)

DAT-L		
BIT0	OVERCURRENT	ERROR 11
BIT1	OVERLOAD	ERROR 12
BIT2	OVERVOLTAGE	ERROR 13
BIT3	PHASELOSS	ERROR 16
BIT4	INVERTER OVERHEAT	ERROR 14
BIT5	THERMO MOT/EXT	ERROR 15
BIT6	LACK OF WATER	ERROR 21
BIT7	MINIMUM THRESHOLD	ERROR 22

DAT-H		
BIT8	ACT. VAL. SENSOR 1	ERROR 23
BIT9	ACT. VAL. SENSOR 2	ERROR 24
BIT10	SETPOINT 1 I<4mA	ERROR 25
BIT11	SETPOINT 2 I<4mA	ERROR 26
BIT12	Reserved	
BIT13	Reserved	
BIT14	Reserved	
BIT15	INTERNAL ERRORS	

As response you will receive the current Failure message as Binary Decoded value.  
e.g.: HYDROVAR has stopped because of a LACK OF WATER error.

**RESPONSE:**

	HEX	
Preset Data High	00	
Preset Data Low	40	=> BIN (DAT-L) = 0100 0000 => LACK OF WATER Error

For detailed Information regarding the Failure messages and how to reset, please look at the HYDROVAR operating instruction!





## Set Minimum Frequency on a Basic Inverter to 25Hz

Typical application: e.g. 1 Master Inverter (ADR. 1) and up to 7 basic Inverters (ADR. 2-8)

The Basic Inverter with Address 3 has to be addressed. (Address Master Inverter = 1)  
Therefore you have to chose with Parameter INVERTER (INDEX = 151 DEZ / 97 HEX) the Inverter with Address 3.

The following line is also shown in the Index List:

Modbus INDEX HEX	Modbus INDEX DEC.	Function	DESCRIPTION	RANGE
97	151	03,06	Inverter	0 = ALL; 1 - 8

The relevant protocols look like this:

### QUERY

	HEX	
Slave Adress	01	Addressing the Master Inverter
Function	06	Present Single Register (Write Function)
Register Address High	00	
Register Address Low	96	Modbus Index 97 (HEX) – Selection of the Inverter (1)
Preset Data High	00	
Preset Data Low	03	
Error Check CRC-High	29	
Error Check CRC-Low	E7	

**Note (1):** The Modbus Registers are addressed starting at zero!  
E.g. Address 97 has to be addressed as 96

### RESPONSE

	HEX	
Slave Adress:	01	
Function	06	
Register Address High	00	
Register Address Low	96	=> Set Parameter INVERTER [0210]
Preset Data High	00	
Preset Data Low	03	=> You have chosen to set the following parameters on Unit 3
Error Check CRC-High	29	
Error Check CRC-Low	E7	



As second step you have to set Parameter Min. Frequency (INDEX = 159 DEZ / 9F HEX) to 25Hz.

The following line is also shown in the Index List:

Modbus INDEX HEX	Modbus INDEX DEC.	Function	DESCRIPTION	RANGE
9F	159	03,06	Min. Frequency	0 - 300

The relevant protocols look like this:

#### QUERY

	HEX	
Slave Address	01	Addressing the Master Inverter
Function	06	Present Single Register (Write Function)
Register Address High	00	
Register Address Low	9E	Modbus Index 9F (HEX) – Min. Frequency (1)
Preset Data High	00	
Preset Data Low	FA	=> FA HEX = 250 DEZ => Sets Min. Freq. to 25.0Hz
Error Check CRC-High	68	
Error Check CRC-Low	67	

#### RESPONSE

	HEX	
Slave Address:	01	
Function	06	
Register Address High	00	
Register Address Low	9E	=> Set Parameter MIN. FREQ. [0250]
Preset Data High	00	
Preset Data Low	FA	=> You set Min. Freq. to 25.0Hz on the Basic Inverter (Addr. 3)
Error Check CRC-High	68	
Error Check CRC-Low	67	



## 6.2 Request Actual Frequency

Typical application: e.g. Single Pump Application (Master Inverter - ADR. 1)

The following line is also shown in the Index List:

Modbus INDEX HEX	Modbus INDEX DEC.	Function	DESCRIPTION	RANGE
35	52	03	Actual Frequency	0 - 700

### QUERY

	HEX	
Slave Address	01	Addressing the Master Inverter
Function	03	Read Holding Register (READ Function)
Starting Address High	00	
Starting Address Low	32	Modbus Index 33 (HEX) – Actual Frequency (1)
No. of Points High	00	To read more than one holding register is not supported by the
No. of Points Low	01	HYDROVAR.
Error Check CRC-High	74	
Error Check CRC-Low	05	

**Note (1):** The Modbus Registers are addressed starting at zero!  
E.g. Address 33 has to be addressed as 32

### RESPONSE

	HEX	
Slave Address:	01	
Function	03	
Byte Count	02	
Data High	01	
Data Low	F4	=> 1F4 HEX = 500 DEZ => Actual Freq. of the Inverter = 50.0 Hz
Error Check CRC-High	B8	
Error Check CRC-Low	53	



**ITT**

**HYDROVAR®**

---

**7 Notes:**



# ITT

# HYDROVAR®

<b>Hauptsitz-Headquarter</b>	
LOWARA S.r.l. - 36075 Montecchio Maggiore - Vicenza - Italy Tel. +39 0444 707111 - Telefax +39 0444 492166 e-mail: lowara.mkt@itt.com - <a href="http://www.lowara.com">http://www.lowara.com</a>	
<b>"RESIDENTIAL AND COMMERCIAL WATER GROUP – EMEA" SALES NETWORK</b>	
MILANO 20090 Cusago – Viale Europa, 30 Tel. 02 90394188 – Fax: 0444 707176 e-mail: lowara.milano@itt.com	LOWARA IRELAND Ltd. 59 Broomhill Drive - Tallaght Industrial Estate Tallaght – DUBLIN 24 – EIRE Tel. +353 (1) 4520266 - Fax: +353 (1) 4520725 e-mail: lowara.ireland@itt.com – <a href="http://www.lowara.ie">http://www.lowara.ie</a>
BOLOGNA 40132 – Via Panigale, 74C Tel. (+39) 051.6415666 – Fax: (+39) 0444 707178 e-mail: lowara.bologna@itt.com	LOWARA FRANCE S.A.S. BP 57311 – 37073 TOURS CEDEX 2 – F Tel. +33 02 47 88 17 17 – Fax: +33 02 47 88 17 00 e-mail: lowarafr.info@itt.com – <a href="http://www.lowara.fr">http://www.lowara.fr</a>
VICENZA 36061 Bassano del Grappa – Via Pigafetta, 6 Tel. 0424.566776 (R.A. 3 Linee) – Fax: 0424.566773 e-mail: lowara.bassano@itt.com	LOWARA FRANCE S.A.S. Agence Sud Z.I. La Sipière - BP 23 13730 Saint Victoret - F Tel. +33 04 42 10 02 30 – Fax: +33 04 42 10 43 75 <a href="http://www.lowara.fr">http://www.lowara.fr</a>
CAGLIARI 09100 – Via Dolcetta, 3 Tel. 070.287762 – 292192 – Fax: 0444 707179 e-mail: lowara.cagliari@itt.com	LOWARA NEDERLAND B.V. Zandweistraat 22 – 4181 CG Waardenburg – NL Tel. +31 (0)418 65 50 60 – Fax: +31 (0)418 65 50 61 e-mail: lowaranl.info@itt.com – <a href="http://www.lowara.nl">http://www.lowara.nl</a>
CATANIA 95027 S. Gregorio – Via XX Settembre, 75 Tel. 095.7123226 – 7123987 – Fax: 095.498902 e-mail: lowara.catania@itt.com	LOWARA PORTUGAL Lda Praçeta da Castanheira, 38–4475-019 Barca – P Tel. +351 22 9478550 – Fax: +351 22 9478570 e-mail: lowarapt.info@itt.com – <a href="http://www.lowara.pt">http://www.lowara.pt</a>
PADOVA 35020 Albignasego–Via A. Volta, 56–Zona Mandriola Tel. 049.8801110 – Fax: 049.8801408 e-mail: lowara.bassano@itt.com	LOWARA PORTUGAL Lda Quinta da Fonte – Edificio D.Pedro I 2770-071 Paço de Arcos Telef.: 21-0001628 Fax: 21-0001675
ROMA 00173 – Via Frascineto, 8 Tel. 06.7235890 (2 linee) – Fax: 0444 707180 e-mail: lowara.roma@itt.com	LOWARA UK Ltd. Main Office- GB Millwey Rise Industrial Estate–Axminster, Devon EX 13 5HU Tel. +44 (01297) 630200 – Fax: +44 (01297) 630270 e-mail: lowarauk.south@itt.com – <a href="http://www.lowara.co.uk">http://www.lowara.co.uk</a>
<b>LOWARA DEUTSCHLAND GmbH</b> Biebigheimer Straße 12 - 63762 GroBostheim (OT Wenigumstadt) -D Tel.+49 (0) 6026 943.0 – Fax:+49 (0) 6026 943-210 e-mail: lowarade.info@itt.com – <a href="http://www.lowara.de">http://www.lowara.de</a>	
<b>BÜRO KALTENKIRCHEN</b> Langwisch 39 - D-24568 Kaltenkirchen Telefon: (0 41 91) 85 06 14 Telefax: (0 41 91) 85 06 15 Mobil: (01 71)483 38 24	<b>BÜRO BERLIN</b> Waldschulalle 5 - D-10115 Berlin Telefon: (030) 28 87 99 00 Telefax: (030) 28 87 99 01 Mobil: (0171) 272 88 16
<b>BÜRO GREVEN</b> Wentruper Mark 48A - D-48268 Greven Telefon: (0 25 71) 99 28 54 Telefax: (0 25 71) 99 28 55 Mobil: (01 75) 205 78 04	<b>BÜRO BERLIN</b> Fischerstrasse 21 - D-14612 Falkensee Telefon: (033 22) 42 96 72 Telefax: (033 22) 42 96 73 Mobil: (0171) 4 90 66 89
<b>BÜRO ERLANGEN</b> Sebaldusstrasse 2 - D-91058 Erlangen Telefon: (09131) 687 31 90 Telefax: (09131) 687 31 91 Mobil: (0171) 4 83 38 22	<b>BÜRO LOHMAR</b> In den Pannenwiesen 2 - D-53797 Lohmar Telefon: (02246) 91 27 95 Telefax: (02246) 91 27 97 Mobil: (0171)319 73 39
<b>BÜRO PLAUEN</b> Robert-Koch-Str. 5 - D-08547 Plauen/JöBnitz Telefon: (03741) 520461 Telefax: (03741) 520466 Mobil: (0171)483 38 23	<b>BÜRO BESELICH</b> Fontanestr. 13 - 65614 Beselich Telefon: (06484) 89 02 83 Telefax: (06484) 89 02 83 Mobil: (0171) 4 83 38 25
<b>BÜRO STUTTGART</b> Wießenfelser Ring 61 D-70806 Kornwestheim Telefon: (07154) 80 07 71 Mobil: (0162) 216 40 01 Telefax: (07154) 80 10 19	

*Engineered for life*



# ITT

# HYDROVAR®

AUSTRALIAN DISTRIBUTOR



**KelairPumps**

CALL 1300 789 466

*When Pump Knowledge Matters*

[www.kelairpumps.com.au](http://www.kelairpumps.com.au)

<b>Pumpenfabrik ERNST Vogel GmbH</b>		
A-2000 Stockerau		
Ernst Vogel-Strasse 2		
Telefon: 02266/604		
Telefax: 02266/65 311		
Internet: <a href="http://www.vogel-pumpen.com">www.vogel-pumpen.com</a>		
<a href="http://www.hydrovar.com">www.hydrovar.com</a>		<b>Facilities in Europa:</b>
<b>A-4600 Wels</b>	<b>A-8054 Graz Seiersberg</b>	<b>Lowara Vogel Polska sp.zo.o.</b>
Haidestrasse 41	Kärtnerstrasse 518	PL-40652 Katowice, ul. Worcella 16
Telefon: 07242/66 8 51,52,53,54	Telefon: 0316/28 6120	Telefon: 0048/32/202 8904
Telefax: 07242/66 8 51/12	Telefax: 0316/28 70 42	Telefax: 0048/32/202 5452
<b>A-6175 Kematen</b>	<b>A-9020 Klagenfurt</b>	
Bahnhofstrasse 31	Schachterlweg 58	
Telefon: 05232/20 0 01	Telefon: 0463/31 93 20	
Telefax: 05232/20 0 03	Telefax: 0463/31 93 17	

*Engineered for life*