

Installation, Operation & Maintenance Manual

Models: E02, E05, E12, E25, E75, E125

AUSTRALIAN DISTRIBUTOR



CALL 1300 789 466
When Pump Knowledge Matters
www.kelairpumps.com.au

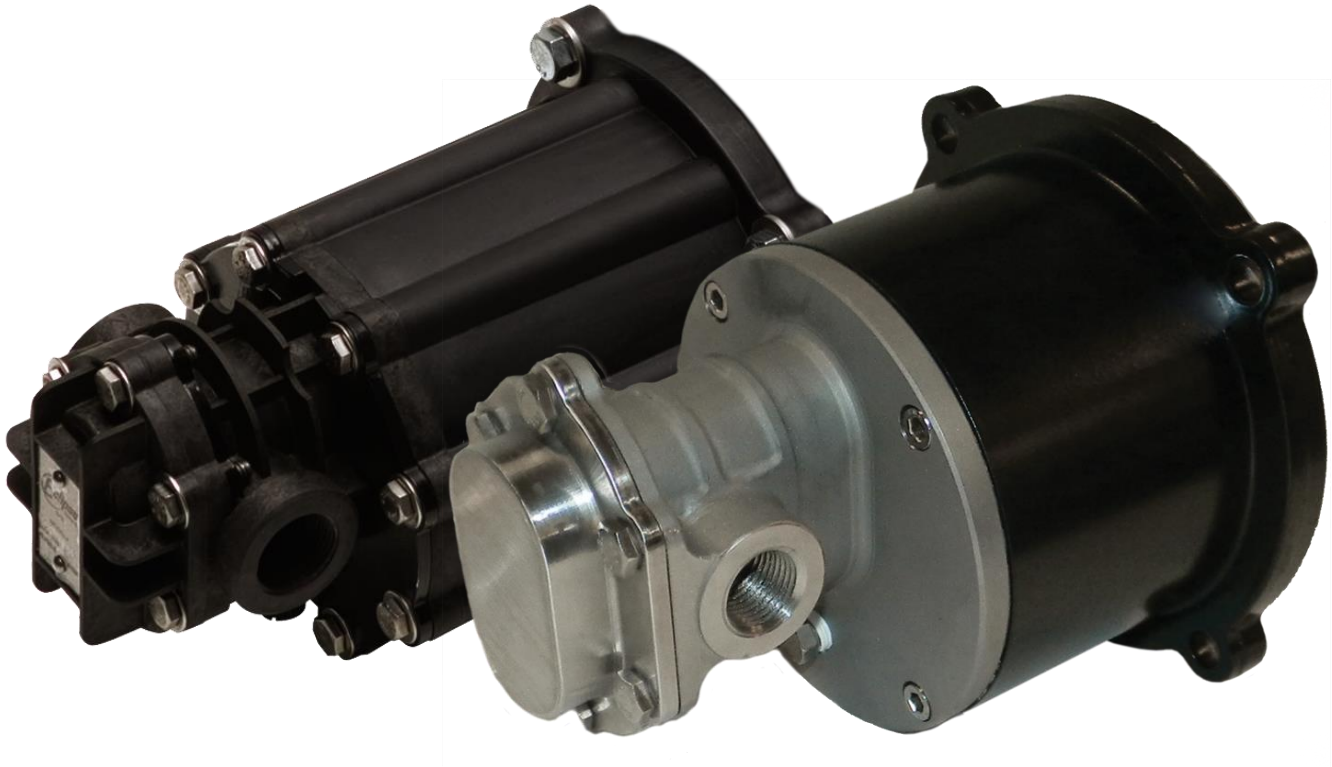

Bulletin: IOM-ECL-3500-Rev.H

ECLIPSE[®]
**EXTERNAL GEAR
METERING PUMP**

Pulsafeeder® Factory Service Policy

Should you experience a problem with your Eclipse pump, first consult the troubleshooting guide in this installation, operation and maintenance manual. If the problem is not covered or cannot be solved, please contact your local Pulsafeeder Distributor or our Technical Services Department for further assistance.

Trained technicians are available to diagnose your problem and arrange a solution. Solutions may include purchase of replacement parts or returning the unit to the factory for inspection and repair. All returns require a Return Authorization number to be issued by Pulsafeeder. Parts purchased to correct a warranty issue may be credited after an examination of original parts by Pulsafeeder. Warranty parts returned as defective, which test good, will be sent back freight collect. No credit will be issued on any replacement electronic parts.

Any modifications or out-of-warranty repairs will be subject to bench fees and costs associated with replacement parts.

Pulsafeeder's Factory Service Policy is maintained online. Please source this document at this URL: <http://www.pulsa.com/pulsa-docs/Pulsafeeder-EPO-Limited-Warranty-Statement.pdf>

All Pulsafeeder Eclipse® manufactured products are guaranteed against defects in materials and workmanship under normal use for 12 months from the date of shipment from the factory. Any modifications or out-of-warranty repairs will be subject to bench fees and costs associated with replacement parts.

Trademarks

Eclipse® is a registered trademark of Pulsafeeder, Inc.

Pulsafeeder® is a registered trademark of Pulsafeeder, Inc.

Viton® is a registered trademark of DuPont Performance Elastomers.

Copyright ©2005/2006 Pulsafeeder Inc. All rights reserved.

Information in this document is subject to change without notice. No part of this publication may be reproduced, stored in a retrieval system or transmitted in any form or any means electronic or mechanical, including photocopying and recording for any purpose other than the purchaser's personal use without the written permission of Pulsafeeder Inc.

Conventions:

The following Conventions are used in this document.



A WARNING DEFINES A CONDITION THAT COULD CAUSE DAMAGE TO BOTH THE EQUIPMENT AND THE PERSONNEL OPERATING IT. PAY CLOSE ATTENTION TO ANY WARNING.



Notes are general information meant to make operating the equipment easier.

Revision History:

- | | |
|----------|---|
| Rev A | <u>Release Date August 2005</u> , first revision |
| Rev B | <u>Release Date December 2005</u>
Updates and corrections to various text throughout
New <i>figure 47</i> showing motor adaptor
Update Specifications and add information on page 44
Update BOM, all models
Add motor rotation vs. flow direction diagram (<i>figure 2b</i>)
Add O-ring reference chart (<i>Section 18</i>) |
| Rev C/C2 | <u>Release Date December 2006</u>
Added new information for model E10
Updated flow curves for all models
Minor updates to Specification pages, remove KalRez O-ring options |
| Rev D | <u>Release December 2006</u>
Model E10 now upgraded to E12, new flow curves, update text |
| Rev E | <u>Release May 2009</u>
Model E125 added, new flow curves, update text |
| Rev F | <u>Release June 2012</u>
Eclipse Hypo Series added, updated text and pictures
Updated KOPkits to new part number format |
| Rev G | <u>Release September 2014</u>
Updated parts listing and removed the Tefzel housings |
| Rev H | <u>Release March 2015</u>
Updated branding, release Eclipse Metallic, updated flow curves |

TABLE OF CONTENTS

1.	INTRODUCTION.....	1
1.1	General Description	1
1.2	Safety Considerations	2
1.3	Liability Exclusions.....	2
1.4	Recycling and End of Product Life.....	2
2.	EQUIPMENT INSPECTION AND STORAGE	3
3.	INSTALLATION.....	4
3.1	General Installation	4
3.1.1	Recommended Accessories.....	5
3.2	Pump Orientation and Motor Direction	5
4.	EQUIPMENT SETUP AND OPERATION.....	6
5.	MAINTENANCE OVERVIEW	7
5.1	Recommended Spares - KOPkits	7
5.1.1	KOPkit Identification	8
5.2	Maintenance precautions for magnet-driven equipment:.....	8
6.	DISASSEMBLY/ASSEMBLY, ECLIPSE 02.....	9
6.1	Disassembly	9
6.2	Assembly.....	13
7.	DISASSEMBLY/ASSEMBLY, ECLIPSE 05/12 AND ECLIPSE 25 METALLIC.....	18
7.1	Disassembly	18
7.2	Assembly.....	22
8.	DISASSEMBLY/ASSEMBLY, ECLIPSE 25/75/125 NON-METALLIC	27
8.1	Disassembly	27
8.2	Assembly.....	31
9.	INSPECTION AND WEAR LIMITS	37
9.1	Service and Replacement Limits	38
10.	TROUBLESHOOTING	39
11.	SPECIFICATIONS	40
11.1	General Specifications – Non-Metallic	44
11.2	Torque Specifications.....	45
12.	PUMP MODEL IDENTIFICATION	46
12.1	KOPkit Part Number Identification	47
13.	PARTS DIAGRAM AND LIST, ECLIPSE 02 NON-METALLIC	48
13.1	PARTS DIAGRAM AND LIST, ECLIPSE 02 METALLIC.....	52
14.	PARTS DIAGRAM AND LIST, ECLIPSE 05 NON-METALLIC	55
14.1	PARTS DIAGRAM AND LIST, ECLIPSE 05 METALLIC.....	59
15.	PARTS DIAGRAM AND LIST, ECLIPSE 12 NON-METALLIC	62
15.1	PARTS DIAGRAM AND LIST, ECLIPSE 12 METALLIC.....	66
16.	PARTS DIAGRAM AND LIST, ECLIPSE 25 NON-METALLIC	69
16.1	PARTS DIAGRAM AND LIST, ECLIPSE 25 METALLIC.....	73
17.	PARTS DIAGRAM AND LIST, ECLIPSE 75 NON-METALLIC	76
18.	PARTS DIAGRAM AND LIST, ECLIPSE 125 NON-METALLIC	81
19.	DIMENSIONAL DRAWINGS	85
19.1	Eclipse 02 Non-Metallic	85
19.2	Eclipse 02 Metallic.....	86
19.3	Eclipse 05 Non-Metallic	87
19.4	Eclipse 05 Metallic.....	88
19.5	Eclipse 12 Non-Metallic	89
19.6	Eclipse 12 Metallic.....	90
19.7	Eclipse 25 Non-Metallic	91
19.8	Eclipse 25 Metallic.....	92
19.9	Eclipse 75/125 Non-Metallic	93
20.	PERFORMANCE CURVES.....	94
21.	ATEX DIRECTIVE.....	100

1. Introduction

1.1 General Description

Pulsafeeder's Eclipse Series pumps safely handle hazardous, highly corrosive, explosive or toxic chemicals. Eclipse Hypo Series pumps are designed specifically for installation into Sodium Hypochlorite applications. The Eclipse Series pumps provide safe, leak-free service because the magnetic coupling eliminates the need for traditional sealing methods, such as mechanical seals or packing.

Eclipse Series gear pumps mount to standard NEMA 56C, 143/145TC and 182/184TC motors and IEC 63, 80, 100 and 112 B3/B14 metric flanged (C-face) motors. This enables the pumps to be close coupled, which provides greater assembled strength, complete isolated enclosure of all moving parts, and compact design. This also eliminates the need for special base plate mounting, shaft couplings and guards, complicated drives, and pump bearing lubrication and maintenance, while minimizing plant real estate for optimum pump installation.

All Eclipse Series pumps transmit rotational torque from the motor shaft to the pump shaft by means of a magnetic drive coupling. A drive magnet assembly attached to an electric motor shaft rotates around a closed end containment shell or "containment can" which seals against the pump center housing with a static o-ring. Inside the can an encapsulated driven magnet assembly is mounted on the end of the pump shaft. As the drive magnet assembly rotates, lines of magnetic flux or force cause the driven magnet assembly to rotate which causes the pump shaft to rotate.

All magnetic drive couplings are designed for satisfactory operation of the pump. The magnetic couplings have an integral safety feature that allows them to "decouple" if the coupling torque limit is exceeded. This situation might occur if foreign material were to jam the pump gears or if unusually high torque was developed on pump start-up. Eclipse Series pumps use permanent rare earth Neodymium Iron magnets that can run decoupled without losing their magnetic strength provided magnet temperatures do not exceed 450°F (232°C).



If the pump is allowed to run for an extended period of time decoupled, high temperatures could be generated through opposing magnetic forces that ultimately would cause the loss of magnetic strength.

Eclipse Series pumps feature continuous operation over wide temperature and pressure variations, constant volume pulsation free flow, the ability to handle wide viscosity variations, and ease of inspection and maintenance. Specific limitations are covered in this manual and summarized in **Section 11 Specifications**.

To achieve successful operation and maximum life from your pump, make sure that the pump selection and materials are compatible with the service and operating conditions of your application.

Pumping fluids containing abrasives should be avoided, as accelerated pump wear will result. Eclipse Series gear pumps are designed to handle clear fluids at varying viscosities. Reference the performance curves in **Section 20** for specific values.

1.2 Safety Considerations

The Eclipse series pumps yield both mechanical and hydraulic capabilities. In consideration of safety, the user should be mindful of the following considerations in regards to personal, nearby personnel, and environmental safety. Please consider the following prior to the installation and operation of an Eclipse pump.

1. Read and understand all related instructions and documentation before attempting to install or maintain this equipment.
2. Observe all special instructions, notes, and cautions.
3. Act with care and exercise good common sense and judgment during all installation, adjustment, and maintenance procedures.
4. Ensure that all safety and work procedures and standards that are applicable to your company and facility are followed during the installation, maintenance, and operation of this equipment.
5. As a positive displacement pump, an Eclipse Series pump will continue to build pressure if the fluid pathway is closed or blocked and can result in excessive and unsafe casing pressure or pump failure.



ECLIPSE SERIES PUMPS CONTAIN POWERFUL MAGNETS; PLEASE USE EXTREME CAUTION IN AREAS WHERE MAGNETS ARE IDENTIFIED. THESE MAGNETS CAN BE HARMFUL TO PACEMAKERS, CELL PHONES, CREDIT CARDS & LAPTOPS. THE RECOMMENDED DISTANCE TO MINIMIZE IMPACT IS AT LEAST 3'. STAY AT LEAST 20 FEET AWAY IF YOU HAVE A PACEMAKER.



NEVER PLACE FINGERS OR HANDS INTO ANY PART OF THE PUMP WHILE THE PUMP IS RUNNING.

1.3 Liability Exclusions

Pulsafeeder, Inc. is unable to monitor the observance of the instructions given in this manual, nor verify the actual working conditions and installation of the equipment, the correct operation and maintenance of the equipment and accessories. An incorrect installation, or misuse of the equipment, may cause serious damage and may pose a danger to persons or property. Any anomalies must be reported to the maintenance supervisor. The user is not authorized to tamper with the machine for any reason.



ATTEMPTS TO DISASSEMBLE, MODIFY OR TAMPER IN GENERAL BY UNAUTHORIZED PERSONNEL WILL VOID THE GUARANTEE AND WILL RELEASE PULSAFEEDER, INC. FROM ANY LIABILITY FOR DAMAGE CAUSED TO PERSONS OR PROPERTY RESULTING FROM SUCH ACTIONS.

Pulsafeeder, Inc. is considered released from any liability in the following cases:

- Improper installation
- Improper use of the equipment by non-professional or inadequately trained operators
- Use not in compliance with regulations in the Country of use
- Lack of maintenance or improperly performed
- Use of non-original spare parts or incorrect parts for the model in question
- Total or partial failure to observe the instructions
- Exceptional environmental events

1.4 Handling and Lifting

Boxes, crates, pallets or cartons may be unloaded using fork lift vehicles or slings dependent on their size and construction. A crane must be used for all pumps in excess of 25 kg (55 lb). Fully trained personnel must carry out lifting, in accordance with local regulations. Slings, ropes and other lifting gear should be positioned where they cannot slip and where a balanced lift is obtained.

1.5 Recycling and End of Product Life

At the end of the service life of an Eclipse pump or its parts, the materials and parts should be recycled or disposed of using an environmentally acceptable method and following all local requirements. If the product contains substances that are harmful to the environment, these should be removed and disposed of in accordance with current regulations. This also includes the liquids and/or gases that may be used in the "seal system" or other utilities.

Make sure that hazardous substances are disposed of safely and that the correct personal protective equipment is used. The safety specifications must be in accordance with the current regulations at all times.

2. Equipment Inspection and Storage



Check all equipment for completeness and accuracy against the order and for any evidence of shipping damage. Shortages or damage should be reported immediately to the freight carrier and to your Pulsafeeder representative or distributor.

Storage of an Eclipse pump for up to 12 months is considered short term. The recommended storage procedures are:

- Leave pump in original shipping carton.
- Store indoors in a dry ambient atmosphere. Avoid temperature variations.
- Leave all shipping plugs in place.
- Contact the motor manufacturer for specific motor storage information.

These instructions should be read carefully by the personnel responsible for installation, operation and maintenance of the equipment and kept in a convenient place for ready reference. It is recommended that a copy of the order documents be kept with this manual as well as a written record of the pump model and serial number, which is on the nametag attached to the pump.

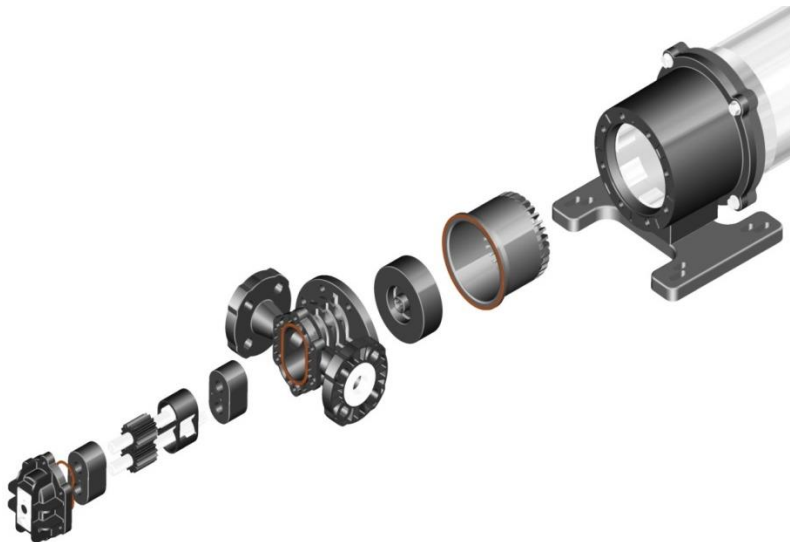

Figure 1 – Parts view of an E75/125

3. Installation



Pump installation site should provide easy access for routine maintenance and protect the pump from environmental elements and from leaks or drips from nearby process equipment.

3.1 General Installation

See Figure 2a for typical installation diagram.

- Keep suction piping system short and straight to minimize friction loss to the pump. Make sure that the pump will not run dry. Flooded suction or gravity fed fluid to pump inlet is preferred.
- Arrange all suction piping and fittings to prevent formation of air pockets. Make sure all joints are airtight.
- Flush and blow out all suction lines prior to mating to pump. Use nipples and unions on both the suction and discharge sides of the pump for ease of maintenance.
- Do not force, bend, or spring either suction or discharge piping when mating up to the pump. Use supports or hangers at intervals as required in an effort to compensate for piping strain due to vector forces and bending forces. When necessary, install thermal expansion joints or accessories so minimal piping strain is placed upon the pump.
- If flexible suction lines are used, be sure their selection and installation will prevent wall collapse which will result in a starved suction condition.
- When taking suction from a tank or vessel, avoid entry of sludge or solids into suction line by placing suction line inlet above maximum expected level of solids.
- Discharge lines should be fitted with a properly sized pressure relief valve to protect both pump and discharge system. The pressure relief valve outlet should be piped back to the supply tank.

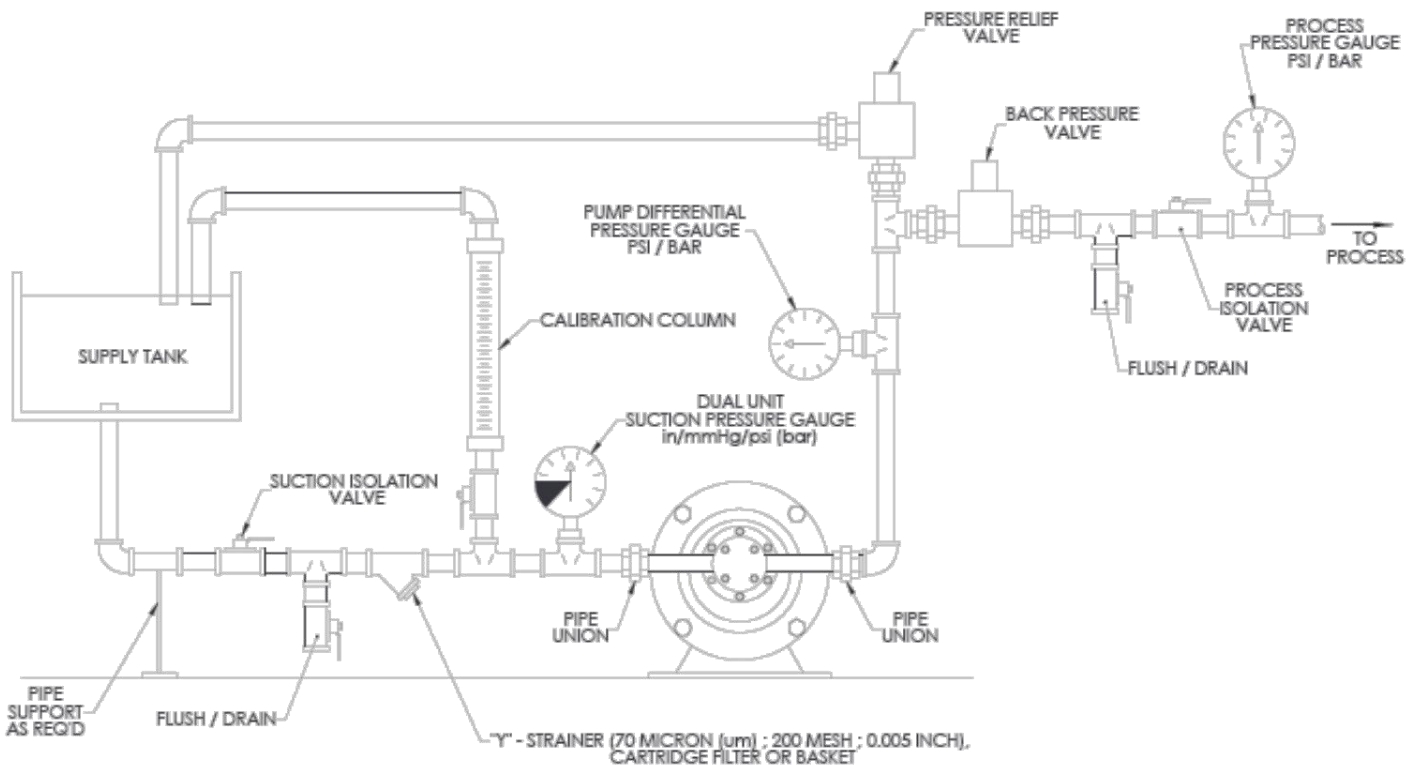

TYPICAL PUMP INSTALLATION

Figure 2a – General Installation

3.1.1 Recommended Accessories

- 70 micron Y strainer
 - Dual unit gage (Hg / psi)
 - Differential pressure gage
 - Pressure relief valve (field adjustable)
 - Back pressure valve (field adjustable)
- If start-up screens are used be sure they do not clog and starve suction. Start-up screens should be removed prior to placing system into regular operation.
 - Installation of vacuum and pressure gauges in the suction and discharge piping is recommended to properly monitor system operation.
 - When a by-pass system is used to control flow from the pump, the bypassed fluid should be piped back to the supply source to prevent heat build-up due to recirculation cavitation. If it is absolutely necessary to pipe by-pass back to the pump suction line, the point of entry should be at least ten times the diameter of the suction pipe away from the suction inlet. Provision for cooling should be made in the event of excessive heat buildup through fluid recirculation.
 - Use only full-bore ball valves or gate valves in the suction piping. If suction strainers are used, select a size to minimize pressure drop and can be easily cleaned and maintained.
 - The pump is designed to self-prime if fluid is supplied at the pump inlet. If foot valves are used, flapper type valves are recommended and should be sized to minimize friction loss.
 - Back pressure valves provide a known, continuous, pressure to the pump. This improves flow stability, measurement, and regulation.



Failure to install and properly set a pressure relief valve (according to manufacturer's specifications) can lead to pump failure and unsafe operating conditions.

3.2 Pump Orientation and Motor Direction

- Bolt the pump motor down firmly to mounting surface. Provide for air movement and circulation over electric motor to enhance proper cooling.
- Direction of flow is dependent on direction of motor rotation. Reversing the motor direction, and therefore the drive shaft rotation direction, reverses flow. This will also change which port is the suction and which is the discharge, see Figure 2b. Since the Eclipse Series pumps can be installed both horizontally (standard) and vertically, it is very important to identify the suction pipe connection which will determine the required motor rotation.
- Wire the motor in accordance with local, national, and motor manufacturer requirements.
- When installed horizontally, make sure the pump housing drain is on the bottom of the pump. If the pump is installed with the drain facing upwards, the rotation of the motor will be incorrect and either needs to be reversed or the pump orientation corrected. Reference the pump drawings in **Section 19** for drain location. If the pump is mounted vertically, the drain plug will be on the left or right side of the pump.

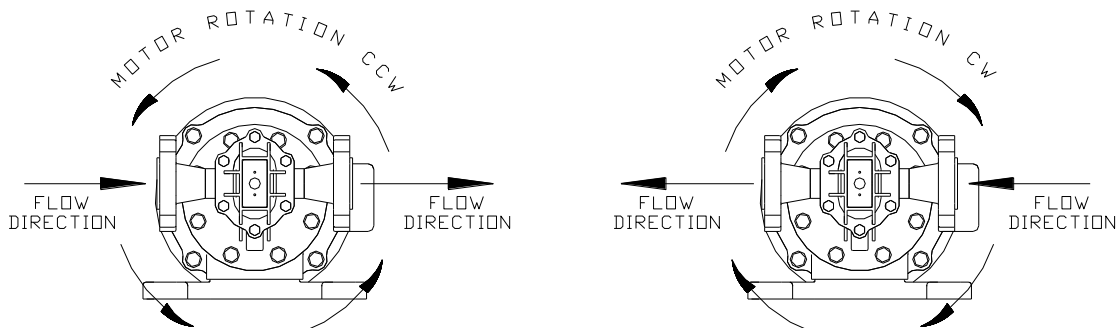

Figure 2b – Flow vs. Motor Rotation

4. Equipment Setup and Operation

- ✓ **Check Hardware Torque** - Hardware and fasteners can loosen during transportation and installation. All pump hardware should be torqued according to the table in **Section 11.2** before operation. Pump hardware should also be checked on a regular basis, especially if the pump is subject to temperature variations or cycling that might cause it to loosen during operation.



All internal rotating components are wetted, lubricated, and cooled by the process fluid. All pumps should be fully wetted and primed prior to regular operation. It is not recommended that any magnetically driven pump be run dry. This condition can cause significant temperature increases resulting in premature damage to the gears and liner from lack of lubrication and/or vaporization of liquid in the pump.

- ✓ **Confirm Flow Direction** - As noted in **Section 3 Installation**, Eclipse Series pumps are bi-directional; the direction of flow is determined by the direction of motor rotation. Refer to Figure 2b.
- ✓ **Adjust PRV** - As a safety precaution, a pressure relief valve by-pass system is highly recommended (see **Section 3.1.1**). Ideally, the pressure relief valve is set for a low pressure at start-up to allow the pump to flood with liquid and evacuate air quickly. It can then be re-adjusted to a setting appropriate to the application.
- ✓ **Open Valves** - Prior to operation, make sure all suction piping is air tight and clean of debris. Start pump with discharge and suction valves open and check for proper operation. Excessive noise or vibration is an indication of harmful cavitation, which may be due to insufficient NPSH (Net Positive Suction Head).



Do not operate the pump against a closed or blocked discharge. Operation against closed or blocked discharge can also result in excessive and unsafe casing pressure. This can also cause the magnetic drive to decouple. This can result in damage to the casing parts and/or containment can. If decoupling occurs, stop the motor and restart after the obstruction has been cleared.



ALL MAGNETIC DRIVE COUPLINGS HAVE A SPECIFIC MAXIMUM TORQUE LIMIT. IF THIS TORQUE IS EXCEEDED THE DRIVE WILL DECOUPLE. OPERATION IN THE DECOUPLED MODE SHOULD BE AVOIDED AS HIGH TEMPERATURES COULD BE GENERATED.

- ✓ **Performance** – Review the performance curves in **Section 20** to reference the expected flow, pressure, and power characteristics for each Eclipse Series pump. Verify that these predicted working conditions correspond to the application. For information and safety precautions specific to a motor speed controller or any other accessories, please refer to the appropriate IOM.

5. Maintenance Overview

Accurate records from the early stages of pump operation will indicate the type and levels of required maintenance. Therefore, regular inspections and detailed maintenance records of past performance can be invaluable for determining future preventative maintenance intervals. For motor maintenance instructions consult the motor manufacturer.

Where pumped fluids may solidify, crystallize, or precipitate, provisions should be made to thoroughly flush pump and piping prior to periods of shutdown. Pay particular attention to proper flushing and draining of the magnetic coupling area because this area may not completely self-drain.



BEFORE PERFORMING ANY MAINTENANCE REQUIRING PUMP DISASSEMBLY, BE SURE TO FLUSH AND DRAIN PUMP THOROUGHLY WITH A NEUTRALIZING FLUID. WEAR PROTECTIVE CLOTHING AND HANDLE EQUIPMENT WITH PROPER CARE.

DISCONNECT THE POWER SOURCE TO THE MOTOR BEFORE PERFORMING ANY MAINTENANCE.

Whenever gear pumps exhibit reduced flow rates, inability to maintain pressures, noisy or otherwise abnormal operation, first refer **Section 10 Troubleshooting**. If the problem cannot be resolved the pump must be inspected for wear or damage. Eclipse Series gear pumps can be easily opened for cleaning and inspection without disturbing piping connections by removing the pump front housing cover. Quite often, original hydraulic performance can be restored by simply changing the KOPkit, as described in **Section 5.1**.



In the event of an unexpected pump stoppage, first ensure the environment is safe to approach the pump and system, following all local procedures and precautions.

Next, refer to **Section 10 Troubleshooting** to determine potential causes and remedies for the stoppage. Follow appropriate power disconnect and Lockout/Tagout procedures.

5.1 Recommended Spares - KOPkits

All Eclipse gear pumps are designed for easy access to the regularly serviced internal components. These components are part of the Keep on Pumping kit, or KOPkit. The KOPkit provides an easy means to keep the right parts for your Eclipse Series pump close at hand.

The basic Eclipse Series KOPkit consists of the following parts, which are recommended as typical spare parts.

- Drive Gear and Shaft Assembly 1 each
- Idler Gear and Shaft Assembly 1 each
- Housing Liner 1 each
- Bearings 2 each
- O-Rings 1 or 2 each

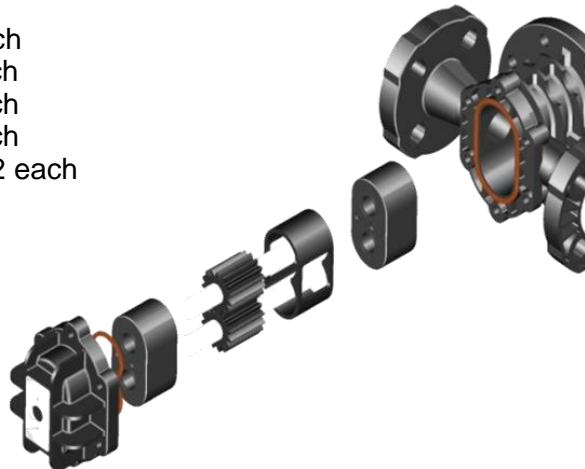

Figure 3 – KOPkit Components

5.1.1 KOPkit Identification

The model number stamped on the pump nameplate identifies the pump type and other details. Refer to the model number chart in **Section 12** if you are unsure of exactly what type of pump you have, or when ordering parts or KOPkits.

Always refer to the full model and serial number in any correspondence with your Pulsafeeder representative. Drawings and consolidated bill of materials for each size pump are included in this manual. Recommended spare parts are identified on the consolidated bill of materials.

The KOPkit for an Eclipse pump can be installed without removing the pump from service. The pump can be disassembled while still connected to the process lines. Take precautions to ensure the pump is safe to work on.

Refer to **Section 9 Inspection and Wear Limits** for internal pump component description of wear and dimensional limits.

5.2 Maintenance precautions for magnet-driven equipment:

- Non-magnetic tools and non-magnetic work surfaces are recommended to perform any disassembly or maintenance of the pump.
- Do not wear a wristwatch in the vicinity of the drive or driven magnets, wristwatches may be damaged by the transmission of magnetic flux.
- The strong magnetic field will damage credit cards, security badges, or other magnetic data strips. Keep them a safe distance from the magnets.



TAKE PRECAUTIONS IN HANDLING PUMP MAGNETS IF YOU HAVE PROSTHETIC DEVICES, METAL OR MEDICAL INSERTS, OR PACEMAKER INSTALLED IN YOUR BODY. CONSULT YOUR PHYSICIAN FOR GUIDANCE IN HANDLING MAGNETS.

- Completely flush and drain pump prior to pump disassembly.
- The exposed magnets on the drive magnet assembly are very fragile and will chip easily. Use extreme care in handling them.
- Take care to avoid magnetic particles or objects from attaching themselves to the drive magnets. It is difficult to remove small particles, and larger objects could be attracted with enough force to break the magnets.



Magnets (both drive and driven) can attract small particles of debris during handling. Always visually inspect the magnetic parts of the pump for cleanliness during re-assembly. Wipe carefully to remove debris, particles, or other small parts without damaging the surface of the magnets.



BE CAREFUL DURING DISASSEMBLY AND REASSEMBLY OF THE DRIVE AND DRIVEN MAGNET ASSEMBLIES. THE MAGNETIC ATTRACTION FORCES ARE HIGH, AND WHEN THE MAGNETS COME CLOSE TOGETHER THERE IS A STRONG TENDENCY TO SNAP TOGETHER SUDDENLY, POTENTIALLY CAUSING INJURY TO FINGERS OR FLESH.



DO NOT MACHINE THE MAGNETS OR MAGNET CARRIERS IN THE DRIVE OR DRIVEN MAGNET ASSEMBLIES. THE MAGNETIC DUST THAT WOULD BE PRODUCED IS HIGHLY FLAMMABLE.



The following sections of the IOM review disassembly and assembly of the Eclipse pump on the service bench. If you are working on your Eclipse pump in the field, the same procedures are used except that your pump will be horizontally mounted, whereas the illustrations in the IOM sections show the pumps in a vertical position.

6. Disassembly/Assembly, Eclipse 02



BEFORE PERFORMING ANY MAINTENANCE REQUIRING PUMP DISASSEMBLY, BE SURE TO RELIEVE PRESSURE FROM THE PIPING SYSTEM, ISOLATE THE PUMP FULLY USING THE APPROPRIATE SHUTOFF/BLOCKING DEVICES, AND, WHERE HAZARDOUS PROCESS MATERIALS ARE INVOLVED, RENDER THE PUMP SAFE TO PERSONNEL AND THE ENVIRONMENT BY CLEANING AND CHEMICALLY NEUTRALIZING AS APPROPRIATE. WEAR PROTECTIVE CLOTHING AND EQUIPMENT AS REQUIRED.

6.1 Disassembly

- Close all suction and discharge valves.
 - Disconnect power source to motor. Follow local Lockout/Tagout procedures.
 - Flush and drain pump
 - Remove piping (optional for KOPkit).
 - The can area will not fully drain and will contain some process fluid.
 - Refer to the Parts Diagram and List in **Section 13**.
1. Remove the motor mounting hardware and slide the entire pump straight off the motor (optional for KOPkit).

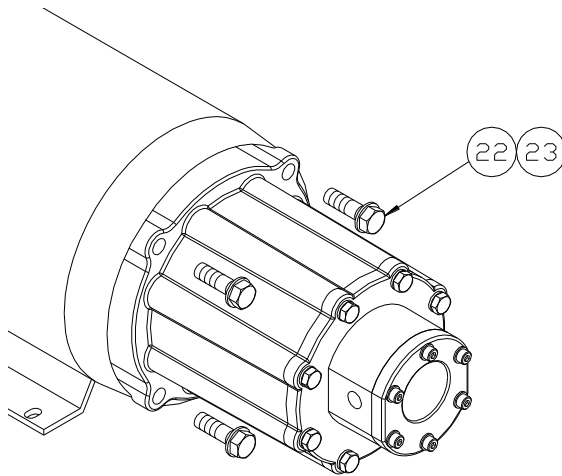

Figure 4 – Non-metallic

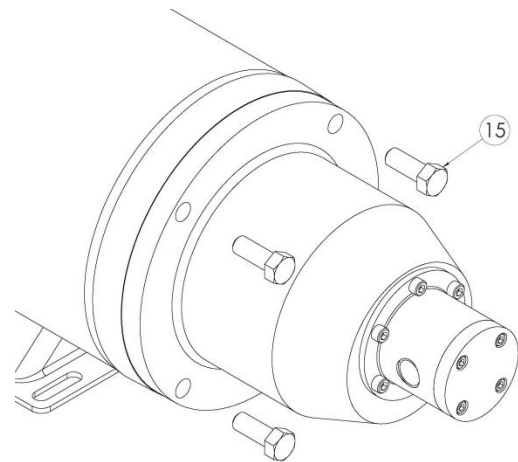

Figure 4 – Metallic

2. Place pump assembly (motor spool down) on the work surface.

3. Remove the front cover hardware and remove front cover as shown.

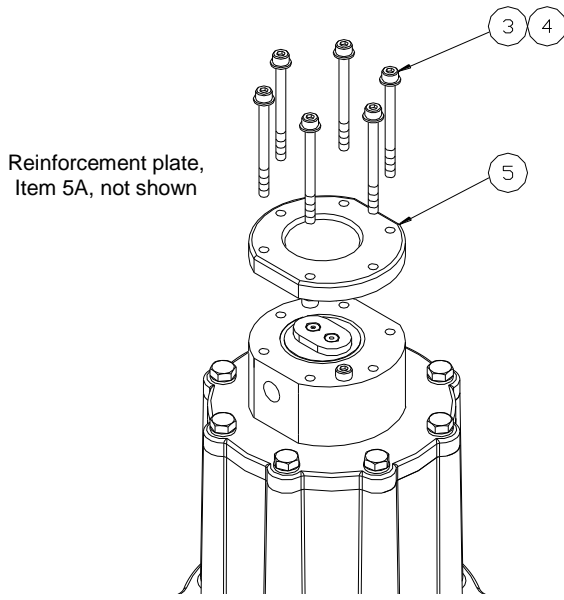

Figure 5 – Non-metallic

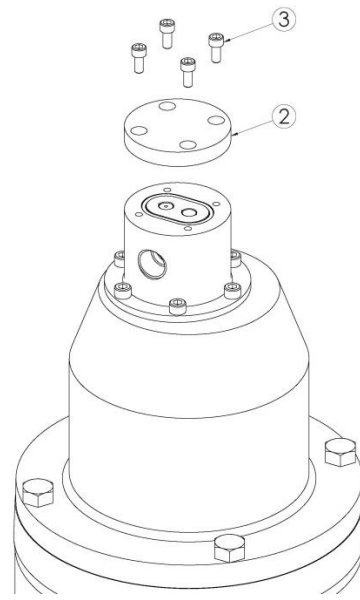

Figure 5 – Metallic

4. Remove bearings, gear/shaft assemblies, and housing liner as shown. These parts, along with the o-rings make up a standard Eclipse Series KOPkit. Check parts for wear and replace with a KOPkit as required.

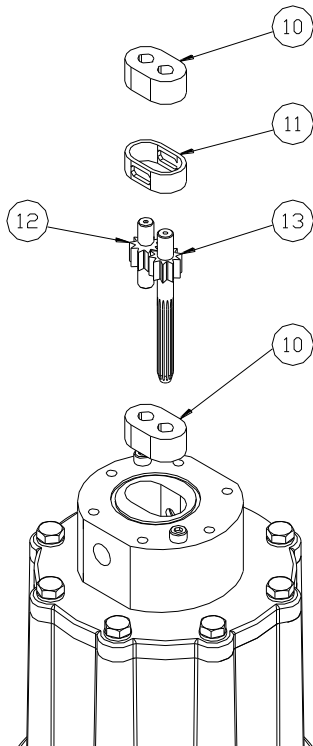

Figure 6 – Non-metallic

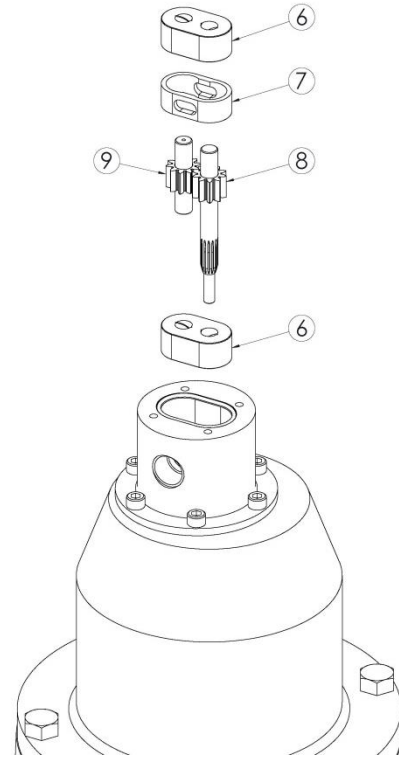

Figure 6 – Metallic

5. Remove the hardware to detach the center housing.
6. Remove all o-rings from the center housing and front cover. Non-metallic pumps have a total of three o-rings. Metallic pumps have two o-rings.

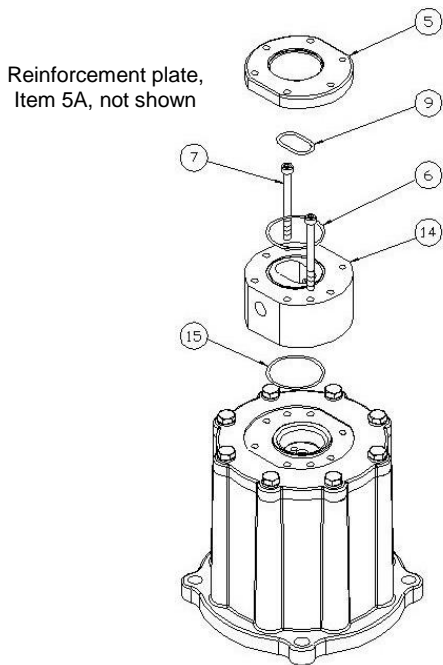

Figure 7 – Non-metallic

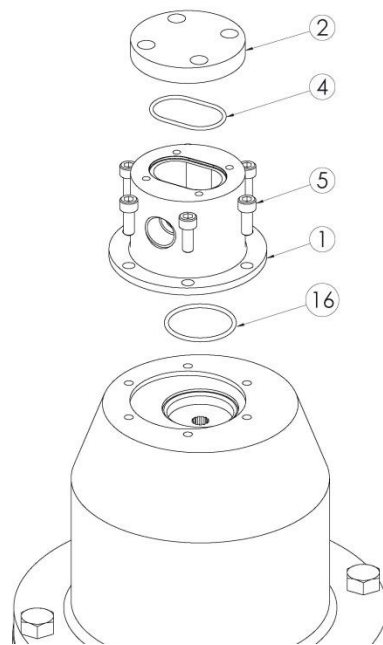

Figure 7 – Metallic

7. Remove the mounting hardware holding the adapter plate to the motor spool and detach the adapter plate. Metallic pumps do not have an adaptor plate, mounting bolts may be removed to detach from motor (if not already removed).
8. Remove driven magnet assembly and containment can from adapter plate or spool as shown.

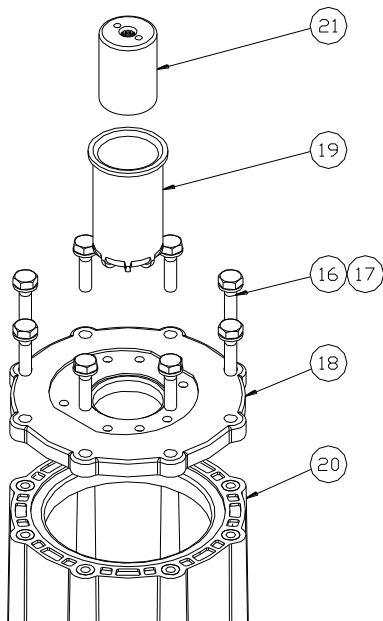

Figure 8 – Non-metallic

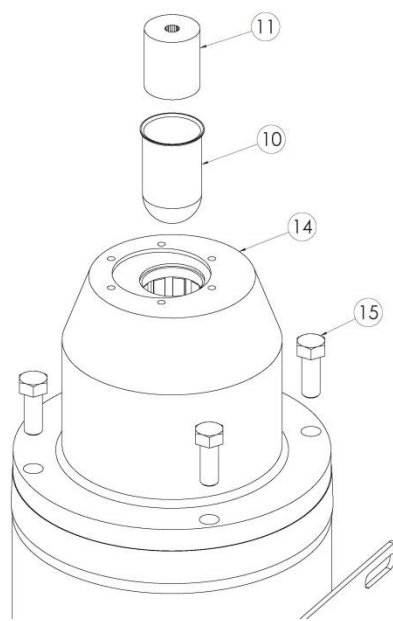

Figure 8 – Metallic



BE CAREFUL DURING DISASSEMBLY AND REASSEMBLY OF THE DRIVE AND DRIVEN MAGNET ASSEMBLIES. THE MAGNETIC ATTRACTION FORCES ARE HIGH, AND WHEN THE MAGNETS COME CLOSE TOGETHER THERE IS A STRONG TENDENCY TO SNAP TOGETHER SUDDENLY, POTENTIALLY CAUSING INJURY TO FINGERS OR FLESH.

9. Remove drive magnet assembly from the motor by loosening the setscrew in the magnet hub and slide off the motor shaft. Retain the key from the motor shaft.
10. If required for non-metallic pumps, the magnet hub (item 25) can be separated from the drive magnet (item 24) by removing the four screws (item 27).

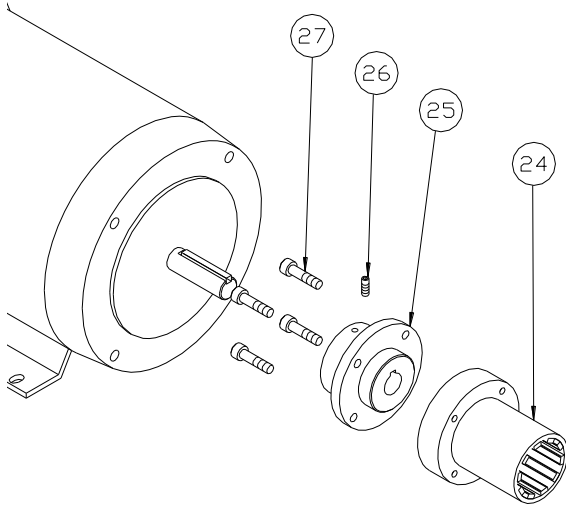

Figure 9 – Non-metallic

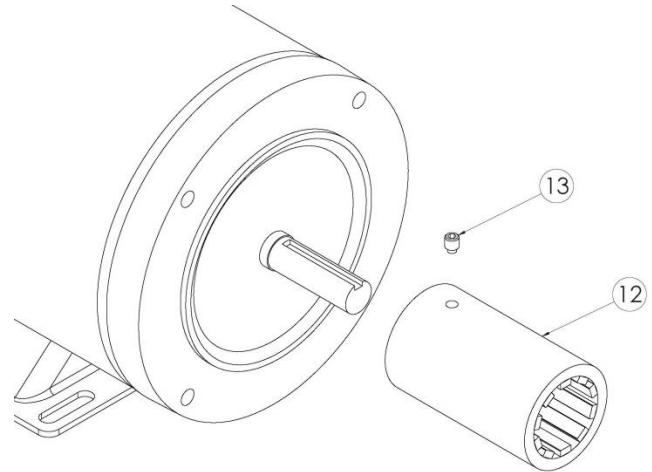

Figure 9 – Metallic

6.2 Assembly

1. Place motor spool flat on work surface. For non-metallic pumps, align “molded-in” flats on the spool adapter plate with any two of the motor mounting bolt holes on the motor spool as shown.
2. Set in place and install mounting bolts and washers. Tighten these bolts to the torque specified in **Section 11.2**. Always tighten fasteners in a progressive “crisscross” pattern.
3. Install the containment can into the spool or adapter plate until it is properly seated into the assembly.
4. Install the driven magnet assembly into the containment can. The driven magnet is symmetrical and can be inserted with either end facing out (orientation does not matter).

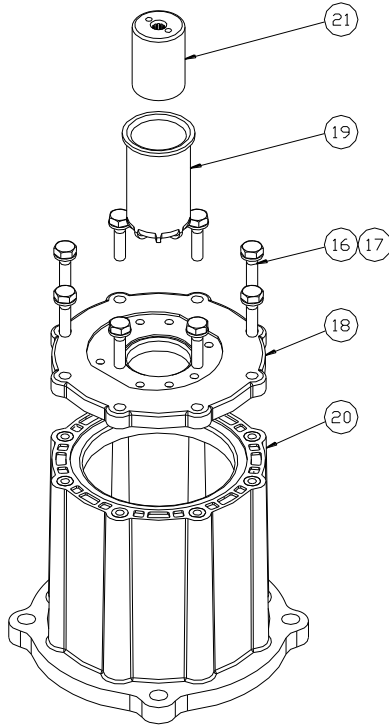

Figure 10 – Non-metallic

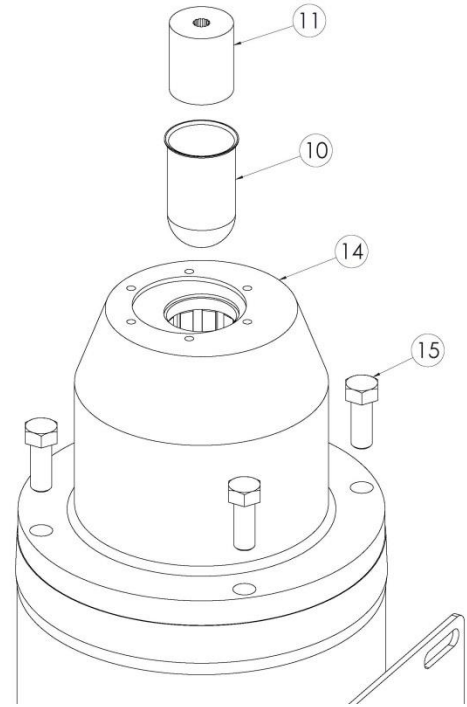

Figure 10 – Metallic

5. Inspect all o-rings to be sure there is no damage such as pinching prior to assembly.
6. Install o-rings into grooves on both sides of the center housing. Some o-ring lubricant may help keep the o-rings in place during assembly. Be sure both o-rings are fully seated into housing grooves.

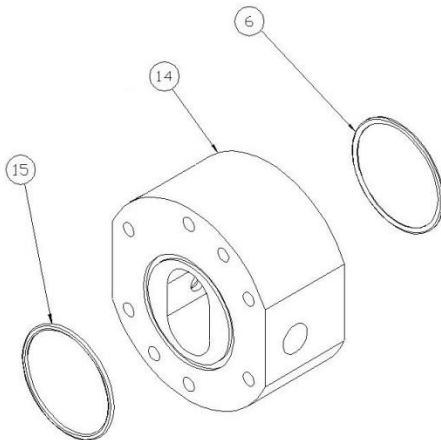

Figure 11 – Non-metallic

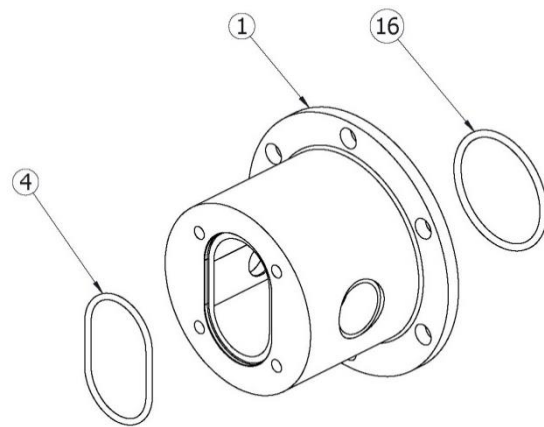

Figure 11 – Metallic

7. Place the center housing with o-rings installed onto the spool or adapter plate (open bore facing out), aligning the flat sides on the center housing to the flat sides on the spool adapter plate as shown on the non-metallic option. If the non-metallic center housing does not sit flat, rotate 180° until it seats into place.
8. Secure the center housing using two bolts in holes as shown on the non-metallic option. Tighten these bolts to the torque specified in **Section 11.2**. Always tighten fasteners in a progressive “crisscross” pattern.

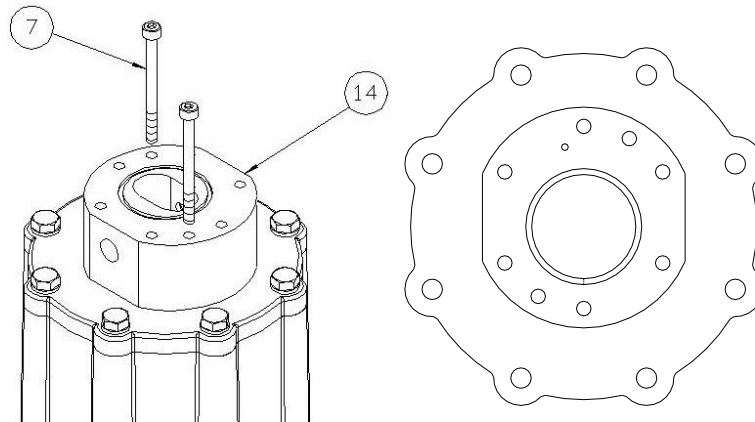

Figure 12 – Non-metallic

9. Insert a bearing into the center housing and slide to the bottom of the housing. Bearings are symmetrical and orientation does not matter.
10. Install the housing liner and slide until it seats against the first bearing. Install the idler gear into the top hole in bearing until the gear seats against the first bearing.
11. Install the drive gear, splined-end first, into the assembly until it bottoms out against the bearing. The shaft may have to be rotated slightly to properly fit the splined-end into the drive magnet and gear to the idler gear assembly.
12. Insert the second bearing into the housing bore until it rests against the housing liner. Bearings are symmetrical and orientation does not matter.

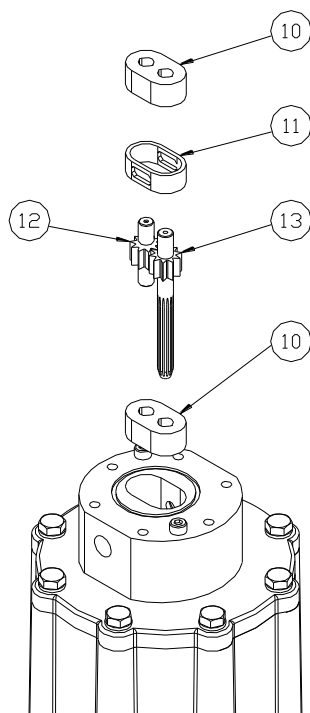

Figure 13 – Non-metallic

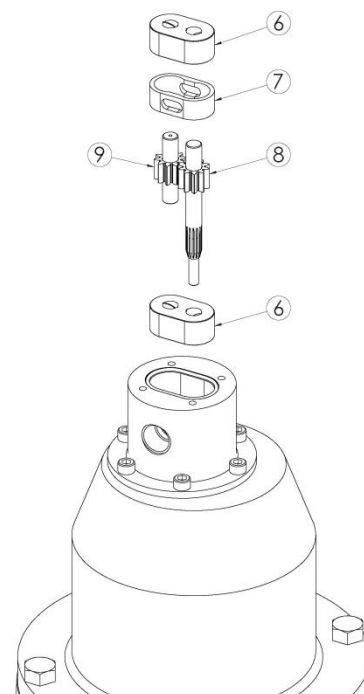

Figure 13 – Metallic

13. For non-metallic pumps, install the spacer o-ring into front cover as shown. Some o-ring lubricant may help keep the o-rings in place during assembly.

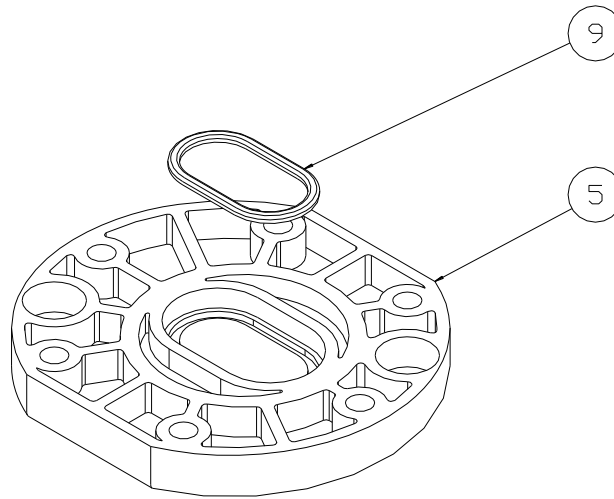

Figure 14 – Non-metallic

14. Install front cover with spacer o-ring. Tighten the bolts to the torque specified in **Section 11.2**. Always tighten fasteners in a progressive “crisscross” pattern.

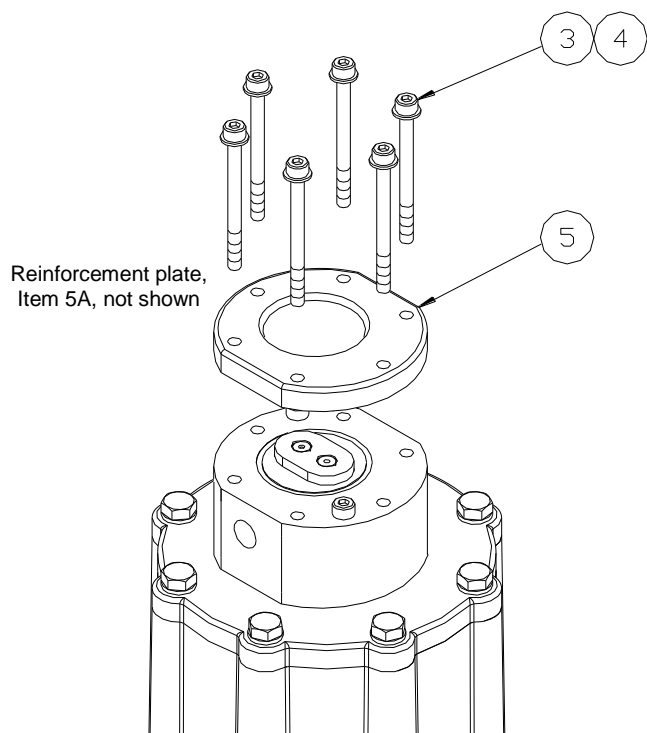

Figure 15 – Non-metallic

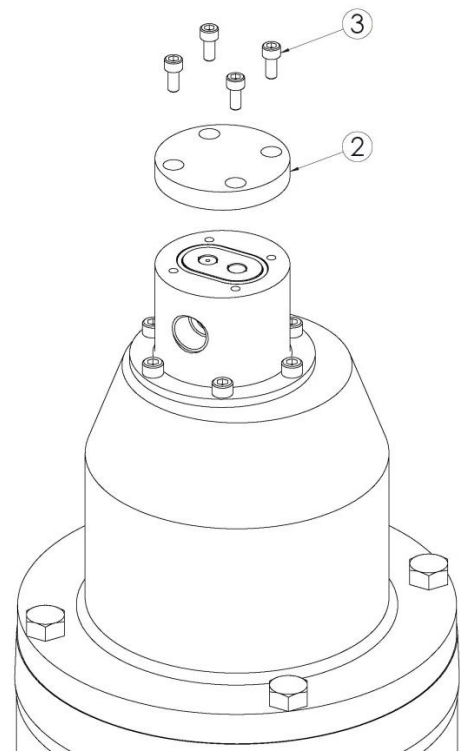

Figure 15 – Non-metallic

15. For non-metallic pumps with IEC frame motors, if the pump was removed from the motor, install the motor adaptor plate (item 31) onto the motor face using the four bolts and washers (items 29 and 30). Always tighten fasteners in a progressive “crisscross” pattern.

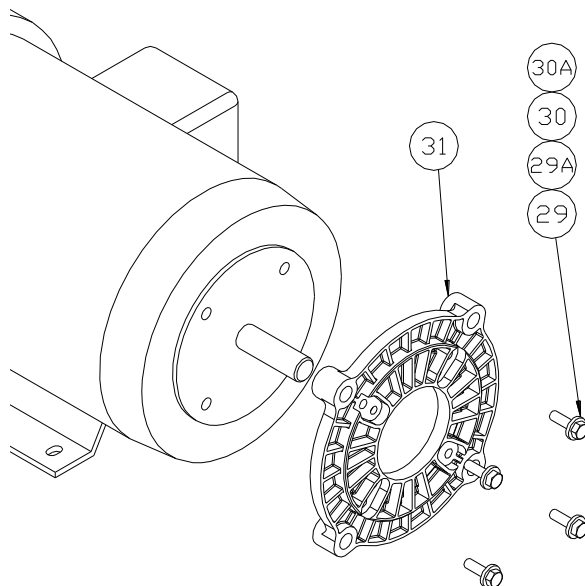

Figure 16 – Non-metallic

16. Secure the magnet hub (item 25) to the drive magnet (item 24) using the four screws (item 27) if disassembled on a non-metallic pump. Always tighten fasteners in a progressive “crisscross” pattern.

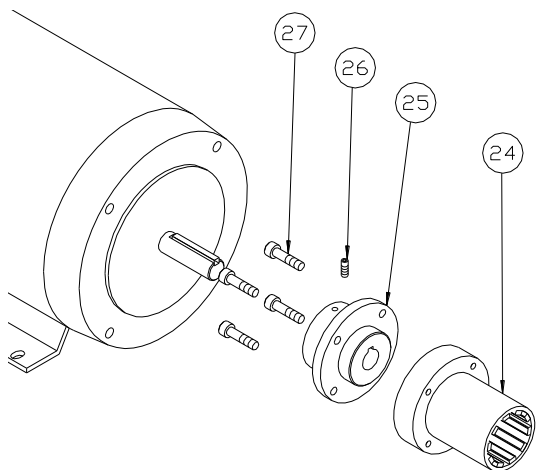

Figure 17 – Non-metallic

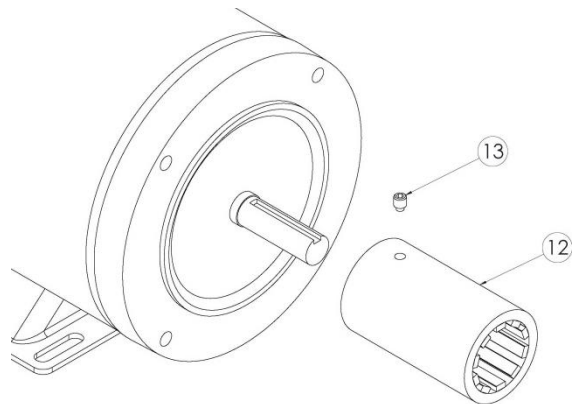

Figure 17 – Non-metallic



BE CAREFUL DURING DISASSEMBLY AND REASSEMBLY OF THE DRIVE AND DRIVEN MAGNET ASSEMBLIES. THE MAGNETIC ATTRACTION FORCES ARE HIGH, AND WHEN THE MAGNETS COME CLOSE TOGETHER THERE IS A STRONG TENDENCY TO SNAP TOGETHER SUDDENLY, POTENTIALLY CAUSING INJURY TO FINGERS OR FLESH.

17. Align the keyway and slide the drive magnet onto the motor shaft until the end of the motor shaft is flush with face of the drive magnet motor or hub as shown in Figure 18. Secure with the setscrew. Application of a no-seize compound on the shaft and key will make future maintenance easier.

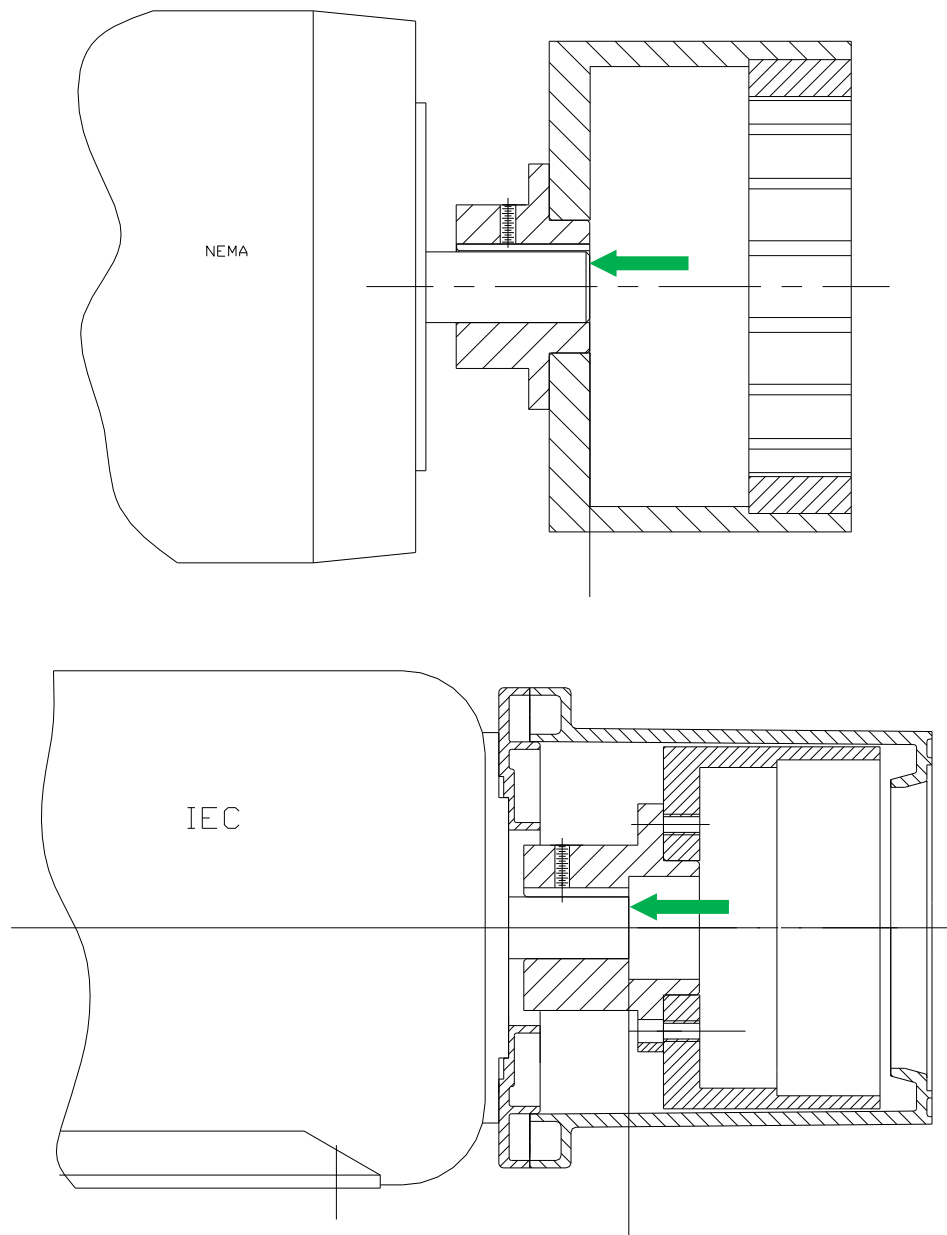

Figure 18

18. Complete assembly by replacing the assembled pump onto the motor, using care not to allow fingers to get pinched when the magnets attract. Secure the pump to the motor with the mounting hardware. Always tighten fasteners in a progressive “crisscross” pattern.

7. Disassembly/Assembly, Eclipse 05/12 and Eclipse 25 Metallic



BEFORE PERFORMING ANY MAINTENANCE REQUIRING PUMP DISASSEMBLY, BE SURE TO RELIEVE PRESSURE FROM THE PIPING SYSTEM, ISOLATE THE PUMP FULLY USING THE APPROPRIATE SHUTOFF/BLOCKING DEVICES, AND, WHERE HAZARDOUS PROCESS MATERIALS ARE INVOLVED, RENDER THE PUMP SAFE TO PERSONNEL AND THE ENVIRONMENT BY CLEANING AND CHEMICALLY NEUTRALIZING AS APPROPRIATE. WEAR PROTECTIVE CLOTHING AND EQUIPMENT AS REQUIRED.

7.1 Disassembly

- Close all suction and discharge valves.
 - Disconnect power source to motor. Follow local Lockout/Tagout procedures.
 - Flush and drain pump
 - Remove piping (optional for KOPkit).
 - The can area will not fully drain and will contain some process fluid.
 - Refer to the Parts Diagram and List in **Section 14, 15, and 16**.
1. Remove the motor mounting hardware and slide the entire pump straight off the motor (optional for KOPkit).

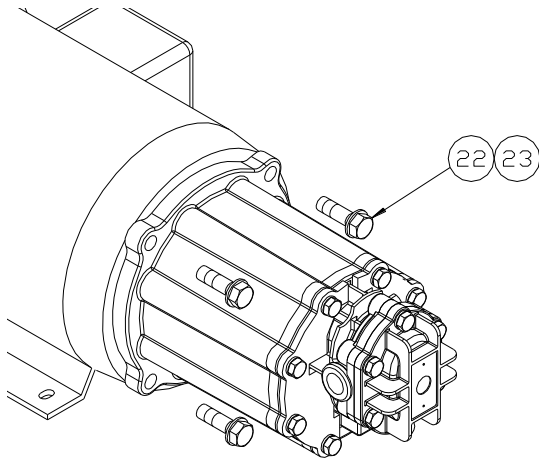

Figure 19 – Non-metallic E05/E12

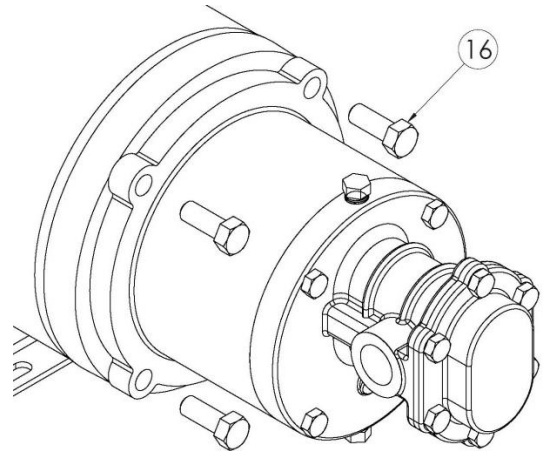

Figure 19 – Metallic E05/E12

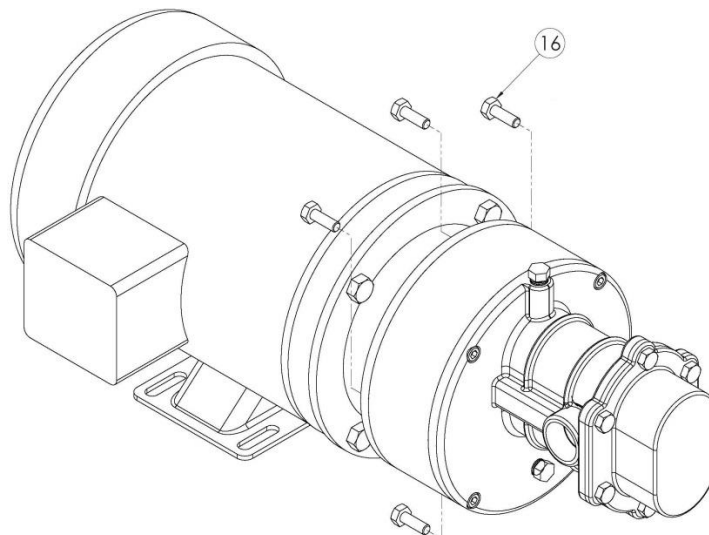

Figure 19 – Metallic E25

2. Place pump assembly (motor spool down) on the work surface.
3. Remove all the front cover hardware and remove front cover as shown.

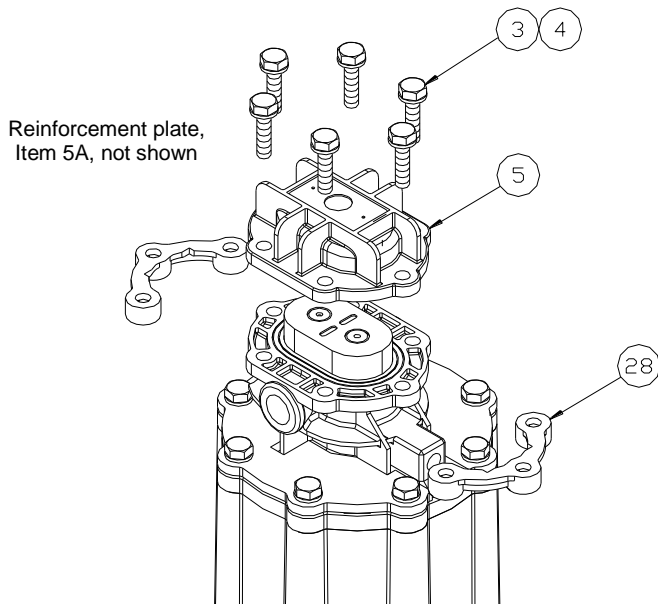

Figure 20 – Non-metallic

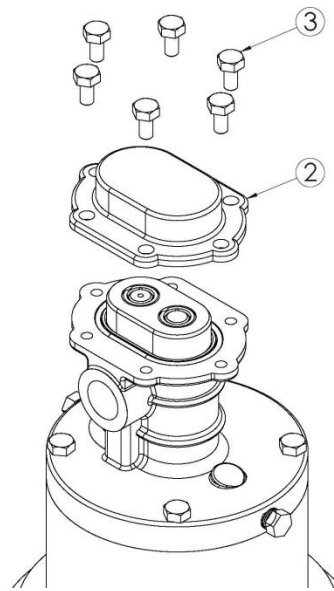

Figure 20 – Metallic

4. Remove bearings, gear/shaft assemblies, and housing liner as shown. These parts, along with the four o-rings make up a standard Eclipse Series KOPkit. Check parts for wear and replace with a KOPkit as required.

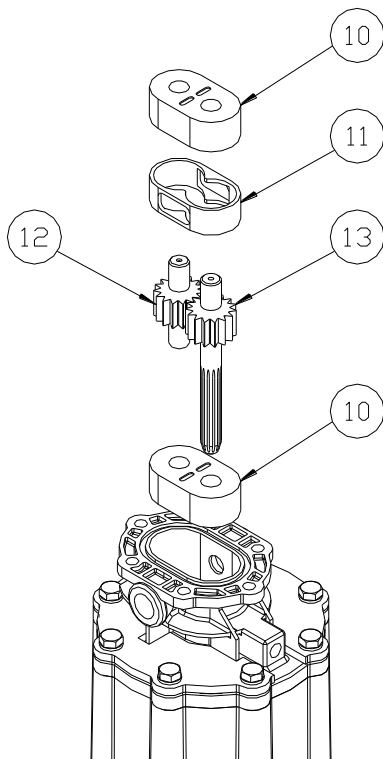

Figure 21 – Non-metallic

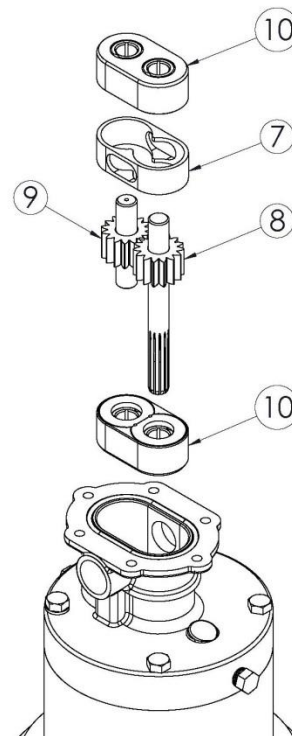

Figure 21 – Metallic

- Remove the hardware holding the center housing to the motor spool. Remove the center housing and retaining plates for non-metallic pumps.
- Remove all o-rings from the center housing and front cover. There are two o-rings in the center housing and one in the front cover as shown.

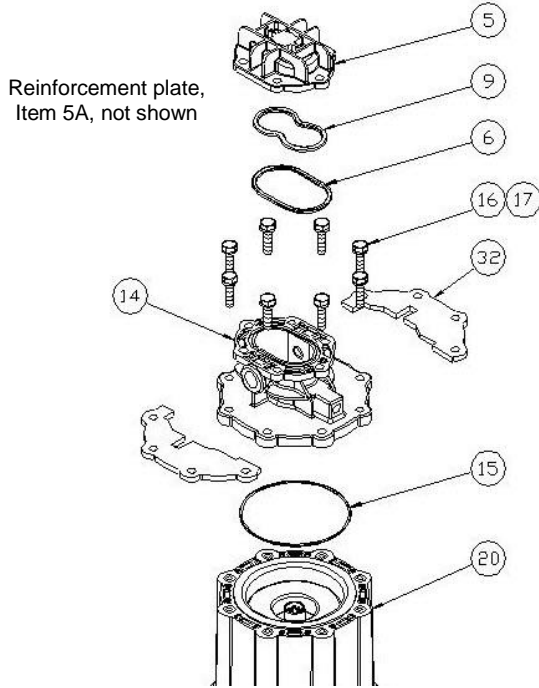

Figure 22 – Non-metallic

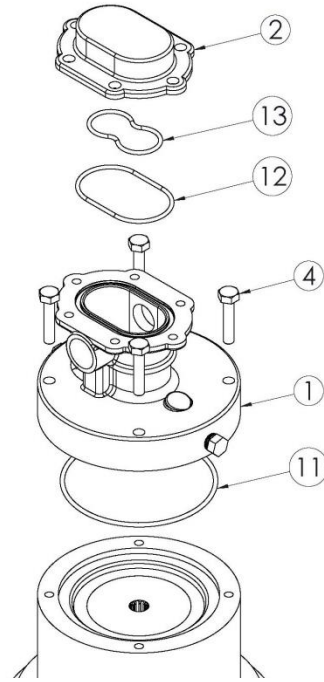

Figure 22 – Metallic

- Remove driven magnet assembly and containment can from the motor spool.

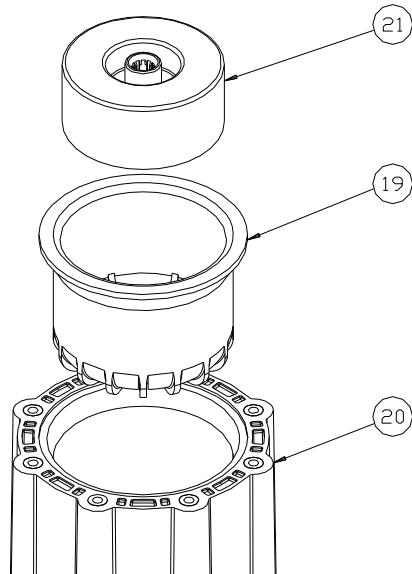

Figure 23 – Non-metallic

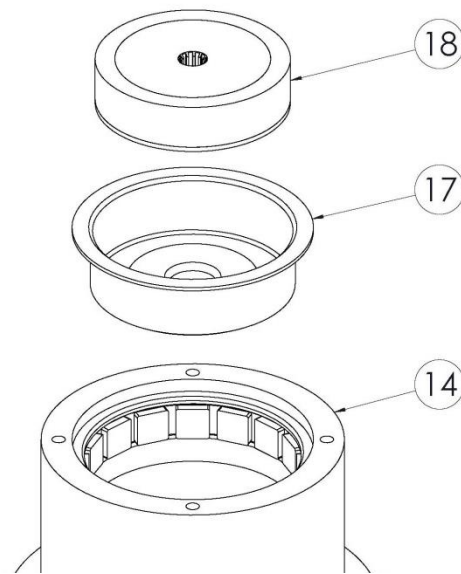

Figure 23 – Metallic



BE CAREFUL DURING DISASSEMBLY AND REASSEMBLY OF THE DRIVE AND DRIVEN MAGNET ASSEMBLIES. THE MAGNETIC ATTRACTION FORCES ARE HIGH, AND WHEN THE MAGNETS COME CLOSE TOGETHER THERE IS A STRONG TENDENCY TO SNAP TOGETHER SUDDENLY, POTENTIALLY CAUSING INJURY TO FINGERS OR FLESH.



BE CAREFUL DURING DISASSEMBLY AND REASSEMBLY OF THE DRIVE AND DRIVEN MAGNET ASSEMBLIES. THE MAGNETIC ATTRACTION FORCES ARE HIGH, AND WHEN THE MAGNETS COME CLOSE TOGETHER THERE IS A STRONG TENDENCY TO SNAP TOGETHER SUDDENLY, POTENTIALLY CAUSING INJURY TO FINGERS OR FLESH.

8. Remove drive magnet assembly from the motor by loosening the setscrew in the magnet hub and slide off the motor shaft. Retain the key from the motor shaft.
9. For E25 metallic pumps, the motor adaptor (item 14) must be removed first. Loosen the set screw in drive magnet assembly through the motor spool (item 29)
10. If required on non-metallic pumps, the magnet hub (item 25) can be separated from the drive magnet (item 24) by removing the four screws (item 27).

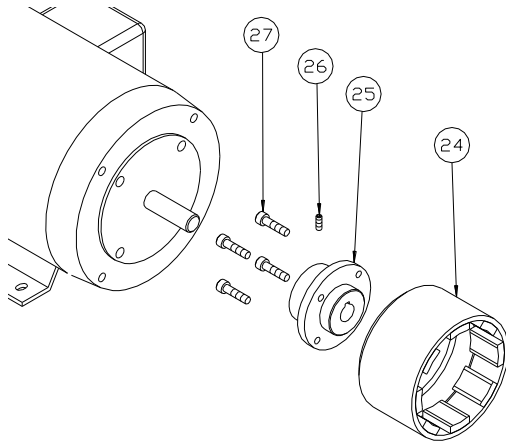

Figure 24 – Non-metallic E05/E12

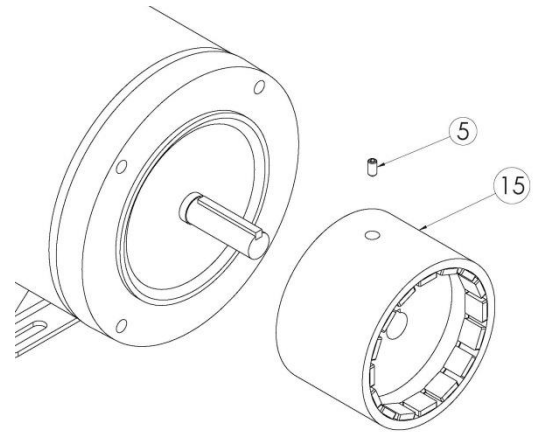

Figure 24 – Metallic E05/E12

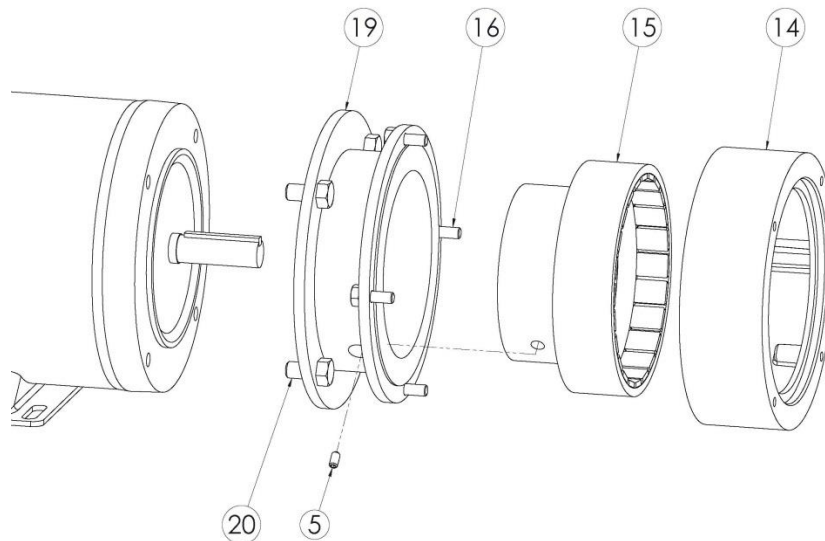

Figure 24 – Metallic E25

7.2 Assembly

1. Place motor spool or adaptor flat on work surface.
2. Insert the containment can and driven magnet into the motor spool as shown. Non-metallic pump driven magnets are symmetrical and orientation does not matter. Metallic pump driven magnets must be installed with the short hub side facing the drive magnet.

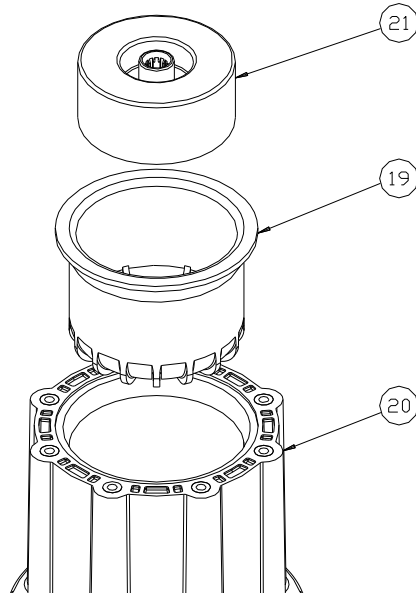

Figure 25 – Non-metallic

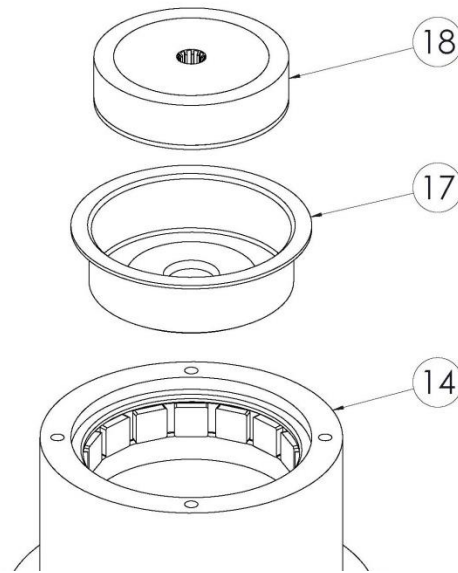

Figure 25 – Metallic

3. Inspect all o-rings to be sure there is no damage such as pinching prior to assembly.
4. Install o-rings into each side of the center housing as shown. Some o-ring lubricant may help keep the o-rings in place during assembly. Be sure both o-rings are fully seated into housing grooves.

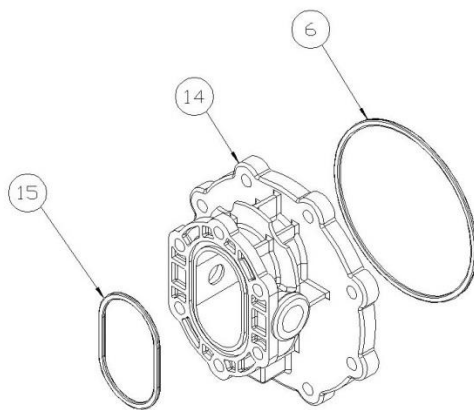

Figure 26 – Non-metallic

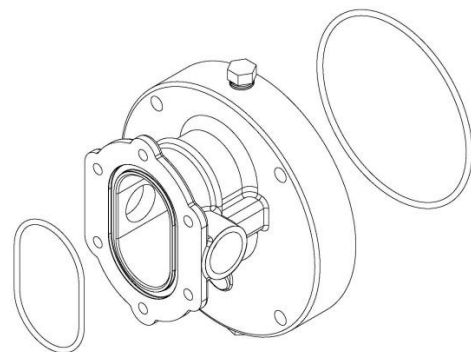

Figure 26 – Metallic

- Place the center housing, with o-rings, onto the motor spool or adaptor, aligning the port connections between any set of motor spool bolt holes as shown. Add the retaining plates for non-metallic pumps. Secure with the center housing hardware. Tighten these bolts to the torque specified in **Section 11.2**. Always tighten fasteners in a progressive “crisscross” pattern.

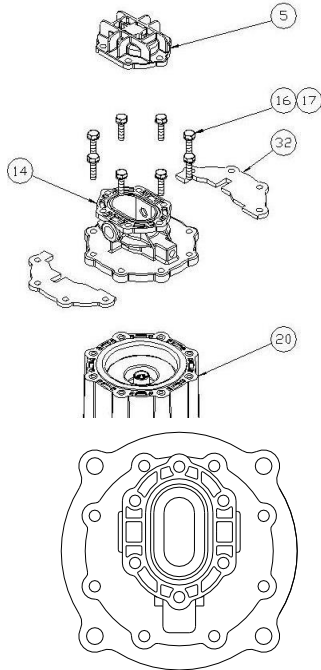

Figure 27 – Non-metallic

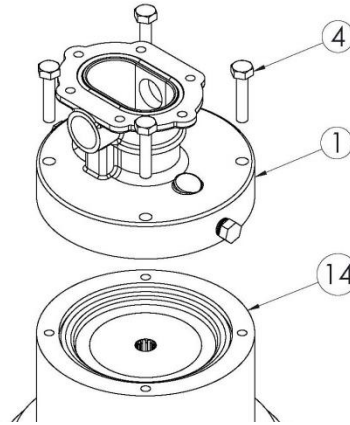

Figure 27 – Metallic

- Insert a bearing into center housing and slide to bottom of bore. Non-metallic pump bearings and some metallic bearings are symmetrical and orientation does not matter. Depending on the configuration, metallic pump bearing assemblies require the wear plates to face the gears. Install the housing liner and slide until it seats against the first bearing. Install idler gear into the top hole in bearing until the gear seats against the first bearing or wear plate.
- Install the drive gear, splined-end first, into the assembly until it bottoms out against the bearing or wear plate. The shaft may have to be rotated slightly to properly fit the splined-end into the drive magnet and mesh gear teeth with the idler gear.
- Insert the second bearing into the housing bore until it rests against the housing liner.

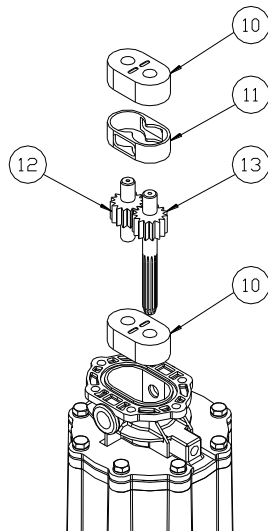

Figure 28 – Non-metallic

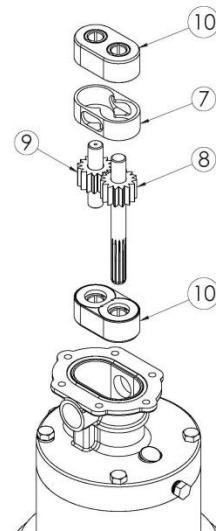

Figure 28 – Metallic

- Install the spacer o-ring into the front cover as shown. Some o-ring lubricant may help keep the o-rings in place during assembly.

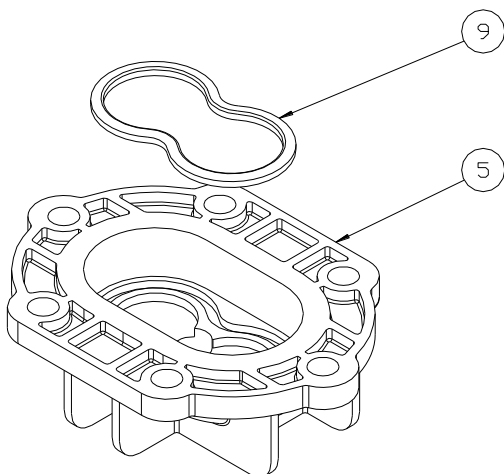

Figure 29 – Non-metallic

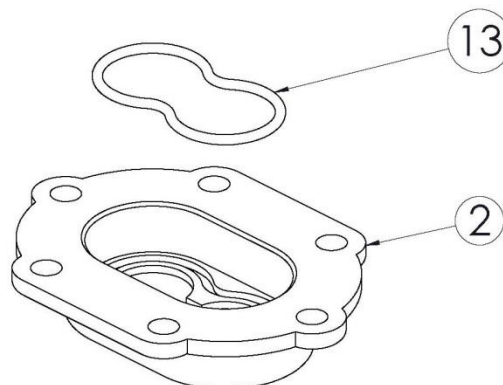

Figure 29 – Metallic

- Place the front cover with o-ring onto the assembled pump. Secure with the front cover hardware. For non-metallic pumps, the flat side of the nut plates (item 28) mates against the back of the center housing flange. Tighten these bolts to the torque specified in **Section 11.2**. Always tighten fasteners in a progressive “crisscross” pattern.

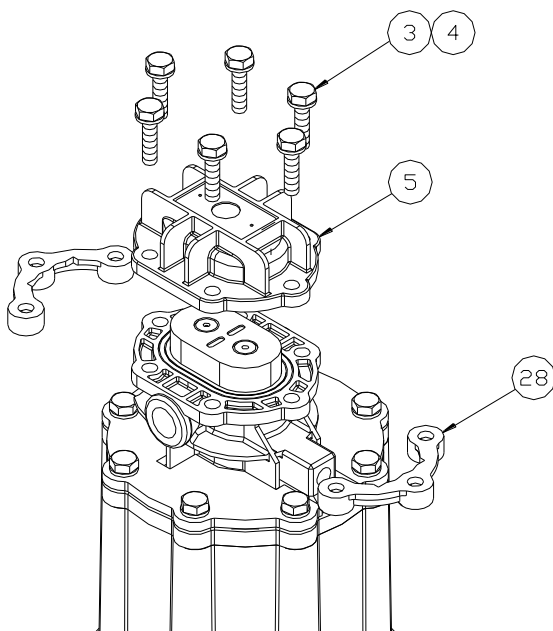

Figure 30 – Non-metallic

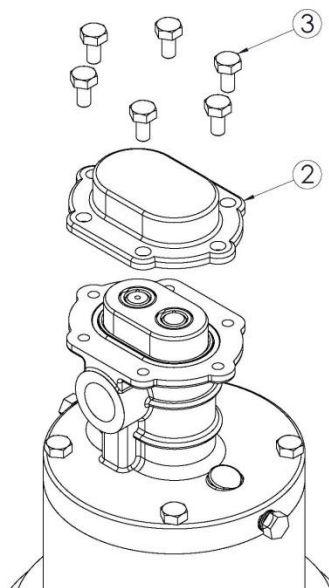

Figure 30 – Metallic

- For non-metallic pumps with IEC frame motors, if the pump was removed from the motor, install the motor adaptor plate (item 31) onto the motor face using the four bolts and washers (items 29 and 30). Always tighten fasteners in a progressive “crisscross” pattern.

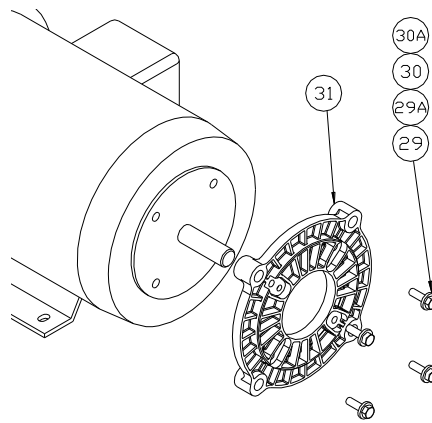

Figure 31 – Non-metallic

12. Secure the magnet hub (item 25) to the drive magnet (item 24) using the four screws (item 27) if disassembled on a non-metallic pump. Always tighten fasteners in a progressive “crisscross” pattern.

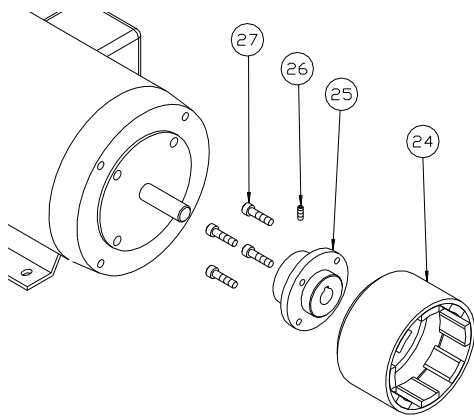

Figure 32 – Non-metallic

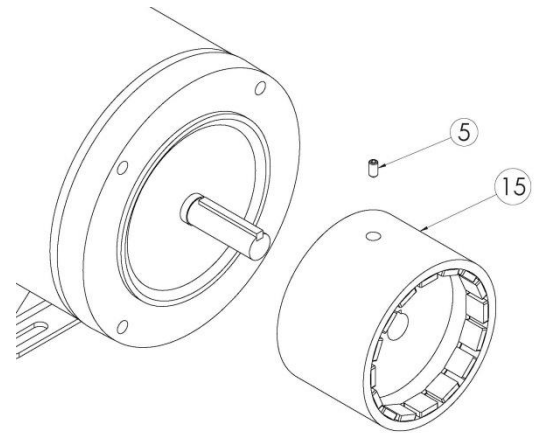

Figure 32 – Metallic

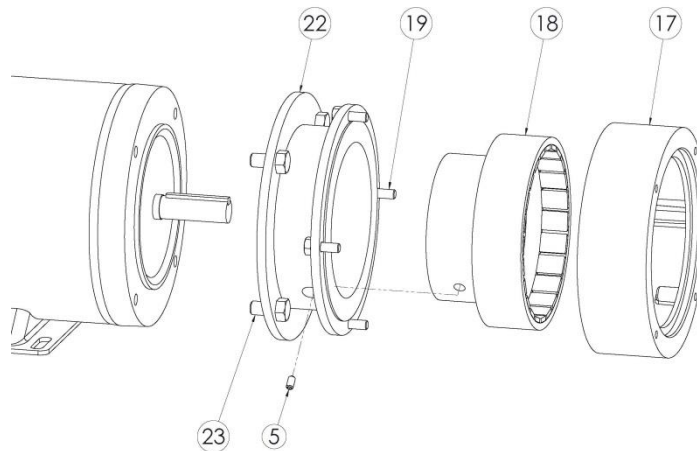

Figure 32 – Metallic E25



BE CAREFUL DURING DISASSEMBLY AND REASSEMBLY OF THE DRIVE AND DRIVEN MAGNET ASSEMBLIES. THE MAGNETIC ATTRACTION FORCES ARE HIGH, AND WHEN THE MAGNETS COME CLOSE TOGETHER THERE IS A STRONG TENDENCY TO SNAP TOGETHER SUDDENLY, POTENTIALLY CAUSING INJURY TO FINGERS OR FLESH.

13. Align the keyway, and slide the drive magnet onto the motor shaft until the end of the motor shaft aligns with faces of the drive magnet motor hub as shown below. Secure with the setscrew

(item 26). Application of a no-seize compound on the shaft and key will make future maintenance easier.

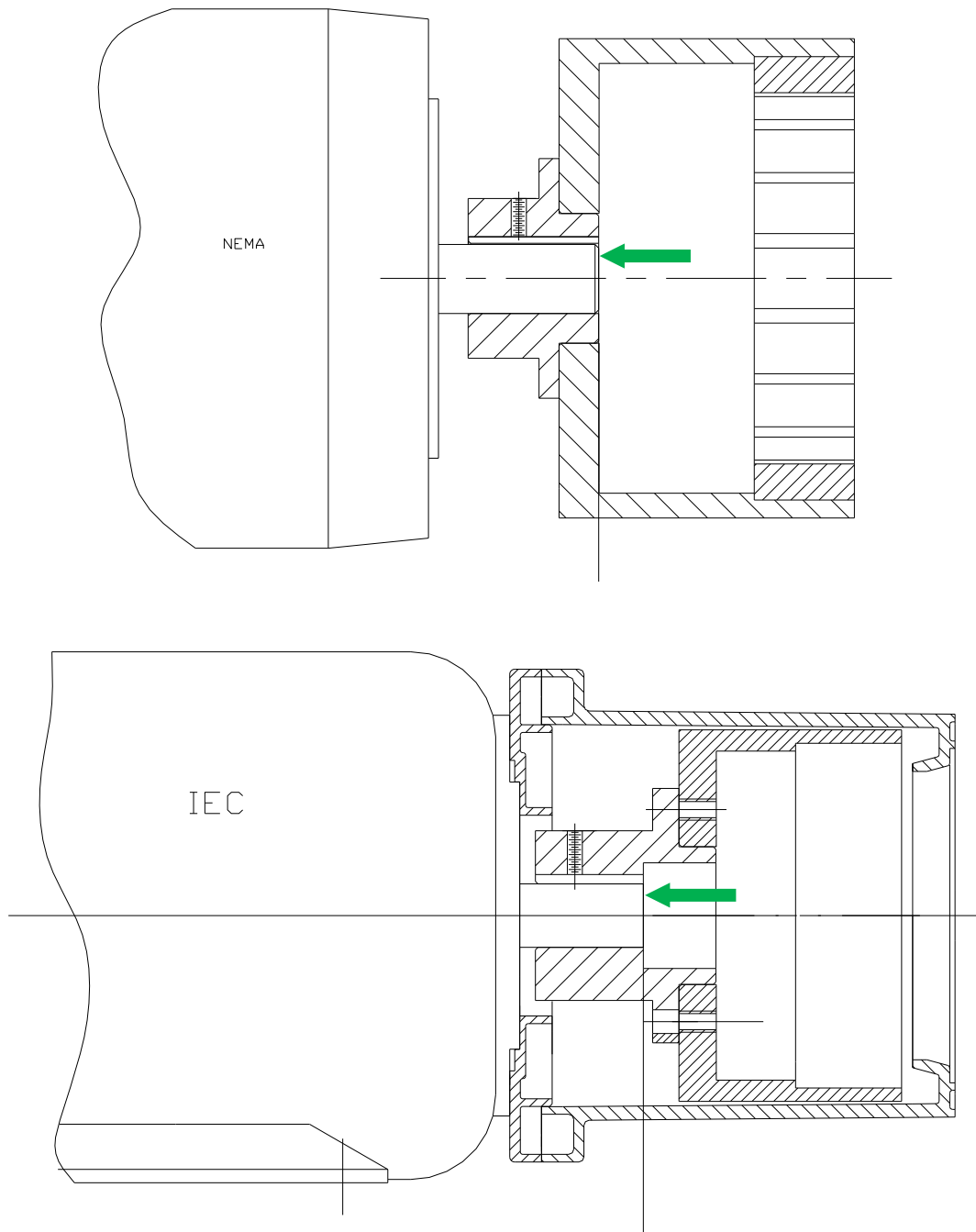

Figure 33

14. Complete assembly by replacing the assembled pump onto the motor, using care not to allow fingers to get pinched when the magnets attract. Secure the pump to the motor with the four bolts and washers. Always tighten fasteners in a progressive “crisscross” pattern.

8. Disassembly/Assembly, Eclipse 25/75/125 Non-Metallic



BEFORE PERFORMING ANY MAINTENANCE REQUIRING PUMP DISASSEMBLY, BE SURE TO RELIEVE PRESSURE FROM THE PIPING SYSTEM, ISOLATE THE PUMP FULLY USING THE APPROPRIATE SHUTOFF/BLOCKING DEVICES, AND, WHERE HAZARDOUS PROCESS MATERIALS ARE INVOLVED, RENDER THE PUMP SAFE TO PERSONNEL AND THE ENVIRONMENT BY CLEANING AND CHEMICALLY NEUTRALIZING AS APPROPRIATE. WEAR PROTECTIVE CLOTHING AND EQUIPMENT AS REQUIRED.

8.1 Disassembly

- Close all suction and discharge valves.
 - Disconnect power source to motor. Follow local Lockout/Tagout procedures.
 - Flush and drain pump
 - Remove piping (optional for KOPkit).
 - The can area will not fully drain and will contain some process fluid
 - Refer to the Parts Diagram and List in Section 16, Section 17, and Section 18.
1. Remove the four motor bolts and washers (items 22, 23) and slide the entire pump straight off the motor (optional for KOPkit).

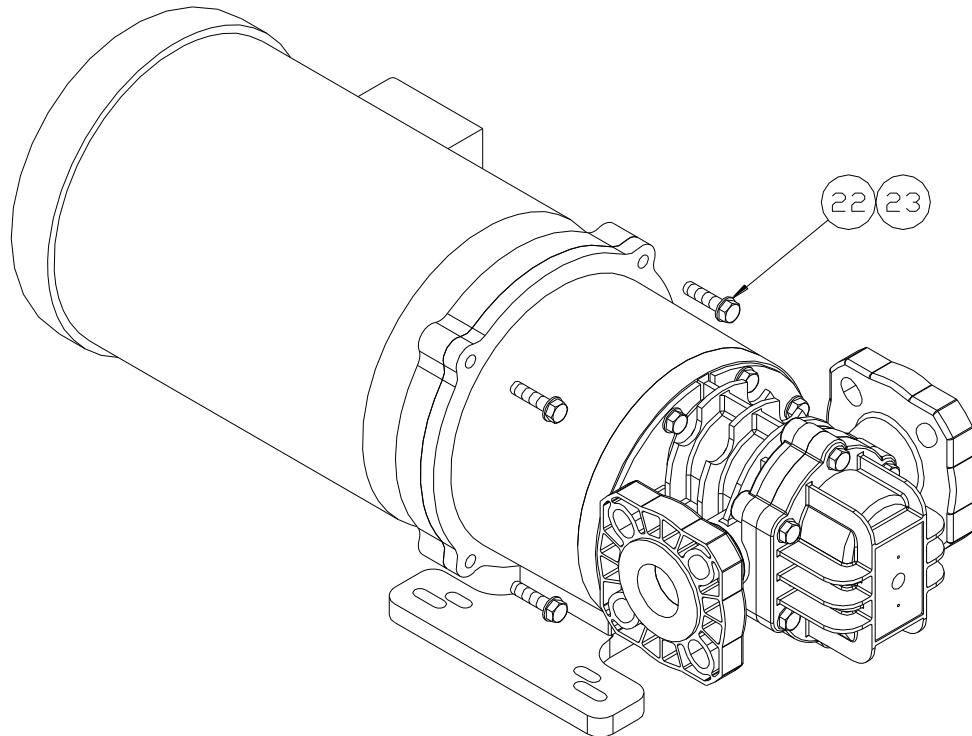

Figure 34

2. Place pump assembly (motor spool down) on the work surface.
3. Remove the six bolts and washers (items 3, 4), remove front cover (item 5) and nut plates (item 28) as shown.

- If required, the mounting base (item 32) can be detached by removing the four bolts and washers (items 33, 34) as shown.

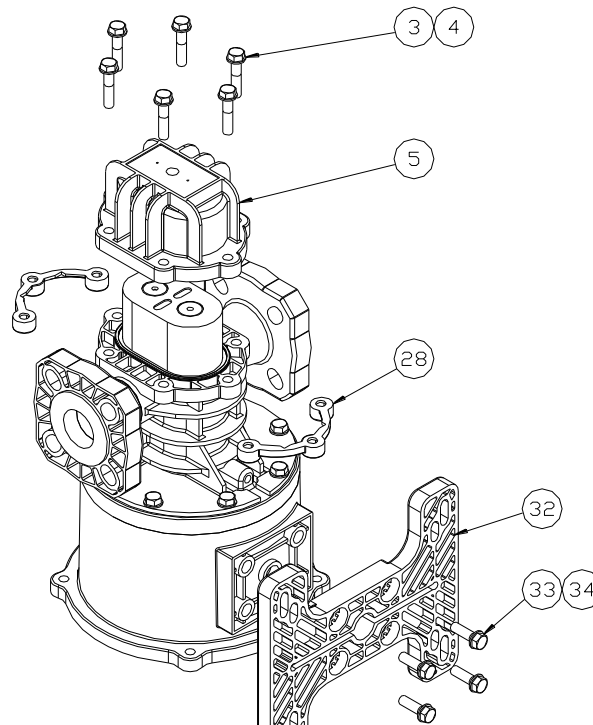

Figure 35

- Remove bearings (item 10), gear/shaft assemblies (items 12, 13) and housing liner (item 11) as shown. These parts, along with the four o-rings make up a standard Eclipse Series KOPkit. Check parts for wear and replace with a KOPkit as required.

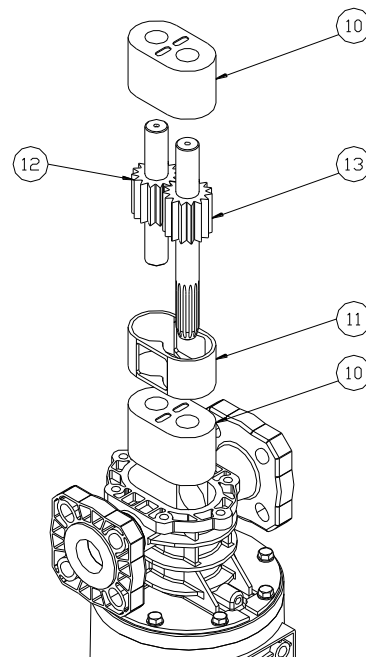

Figure 36

- Remove the eight mounting bolts and washers (items 16, 17) holding the center housing (item 14) to the motor spool (item 20). Detach the center housing and retaining plates (item 35).

7. Remove all o-rings from the center housing and front cover. There is one o-ring in the center housing (item 15) and two in the front cover (items 6, 9) as shown.

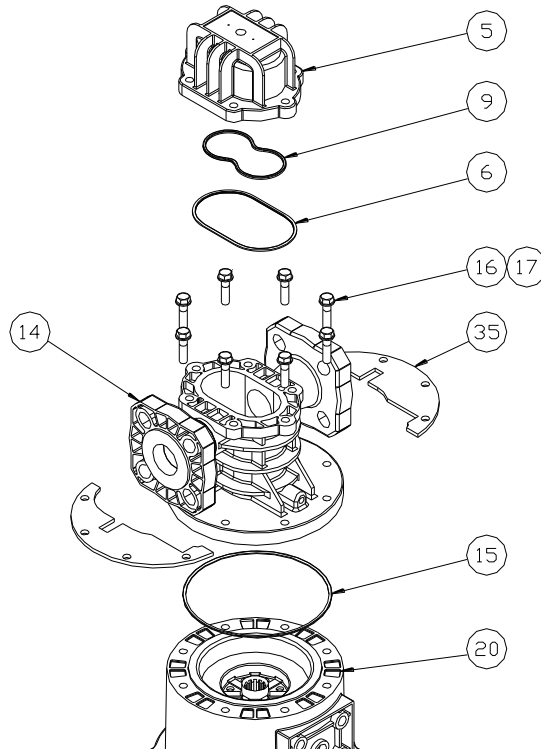

Figure 37

8. Remove driven magnet assembly (item 21) and containment can (item 19) from the motor spool (item 20) as shown.

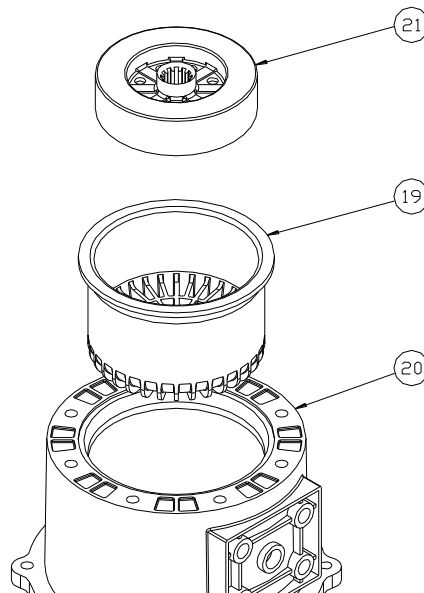

Figure 38

9. Remove drive magnet assembly from the motor by loosening the setscrew (item 26) in the magnet hub (item 25) and slide off the motor shaft. Retain the key from the motor shaft.

10. If required, the magnet hub (item 25) can be separated from the drive magnet (item 24) by removing the four screws (item 27) and detaching.



BE CAREFUL DURING DISASSEMBLY AND REASSEMBLY OF THE DRIVE AND DRIVEN MAGNET ASSEMBLIES. THE MAGNETIC ATTRACTION FORCES ARE HIGH, AND WHEN THE MAGNETS COME CLOSE TOGETHER THERE IS A STRONG TENDENCY TO SNAP TOGETHER SUDDENLY, POTENTIALLY CAUSING INJURY TO FINGERS OR FLESH.

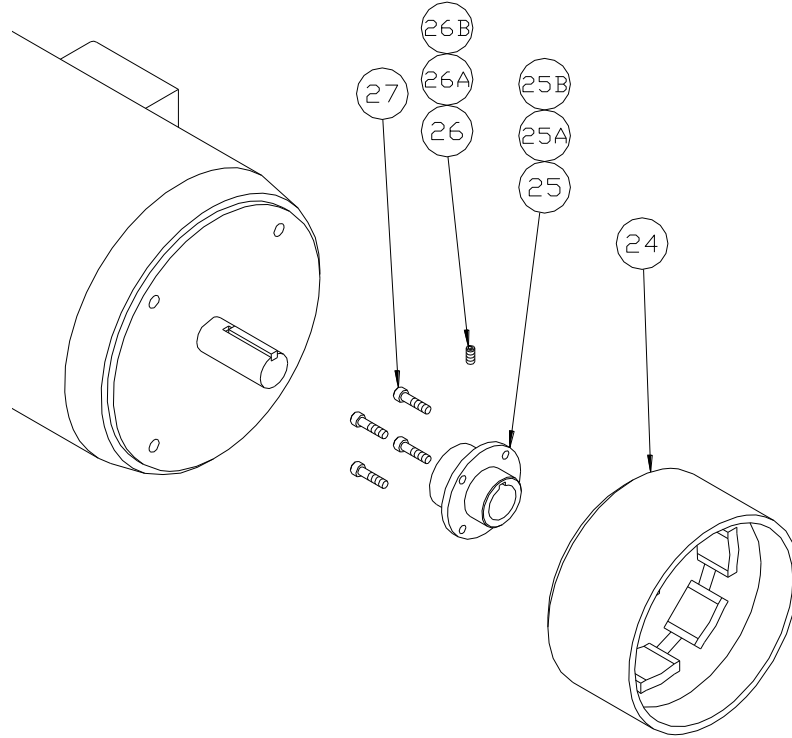

Figure 39

8.2 Assembly

1. Place motor spool flat on work surface.
2. Insert containment can (item 19) and driven magnet (item 21) into motor spool (item 20) as shown. The driven magnet is symmetrical and orientation does not matter.

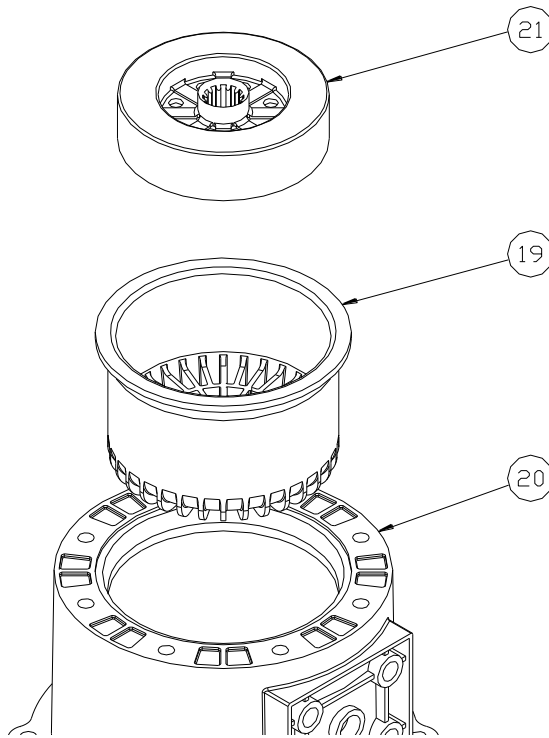

Figure 40

3. Inspect all o-rings to be sure there is no damage such as pinching prior to assembly.

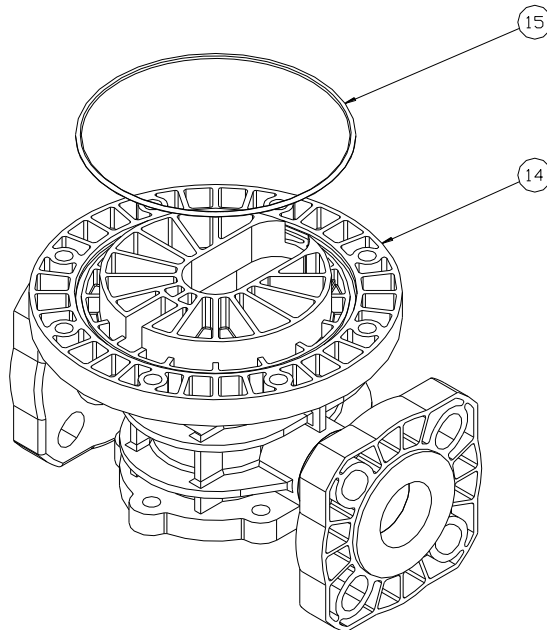

Figure 41

4. Install o-ring (item 15) into the back side of the center housing (item 14) as shown. Some o-ring lubricant may help keep the o-rings in place during assembly. Be sure the o-ring is fully seated into housing groove.

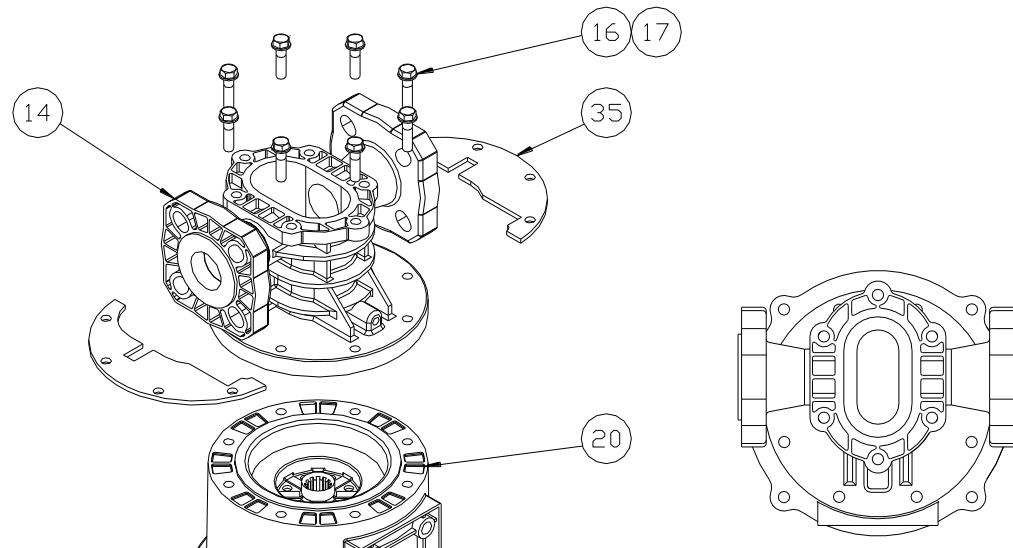

Figure 42

5. Place the center housing (item 14) onto the motor spool, aligning the port connections with the pump baseplate as shown. Place the two retaining plates (item 35) onto the center housing and secure with eight bolts and washers (items 16, 17). Tighten bolts to the torque specified in **Section 11.2**. Always tighten fasteners in a progressive “crisscross” pattern.
6. Insert a bearing (item 10) into center housing (item 14) and slide to bottom of bore. Bearings are symmetrical and orientation does not matter. Install the housing liner (item 11) and slide until it seats against the first bearing. Install idler gear (item 12) into the top hole in the bearing until the gear seats against the first bearing.
7. Install the drive gear (item 13), splined-end first, into the assembly until it bottoms out against the bearing. The shaft may have to be rotated slightly to properly fit the splined-end into the drive magnet and mesh gear teeth with the idler gear.

8. Insert the second bearing into the housing bore until it rests against the housing liner. Bearings are symmetrical and orientation does not matter.

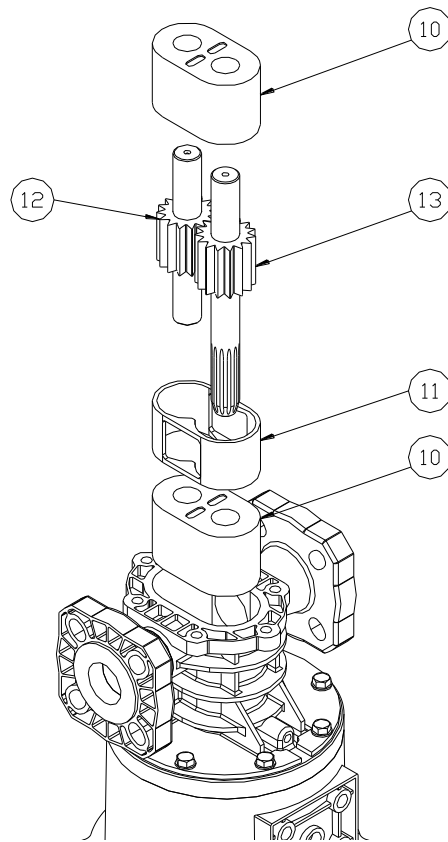

Figure 43

9. Install the two o-rings (items 6, 9) into the front cover (item 5) as shown. Some o-ring lubricant may help keep the o-rings in place during assembly.

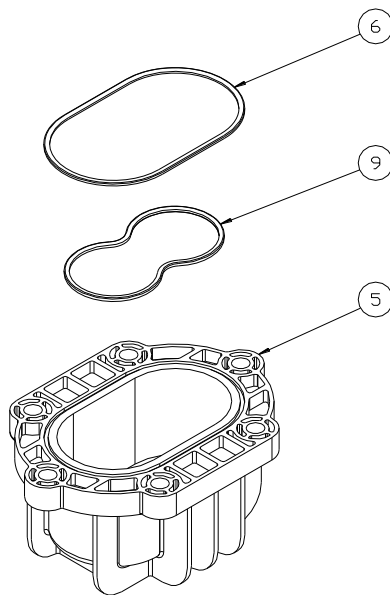

Figure 44

10. Place the front cover (item 5) with o-ring onto the assembled pump. Secure the front cover using the six bolts and washers (items 3, 4) and two nut plates (item 28) as shown. The flat side of the nut plates mates against the back of the center housing flange. Tighten bolts to the torque specified in **Section 11.2**. Always tighten fasteners in a progressive “crisscross” pattern.

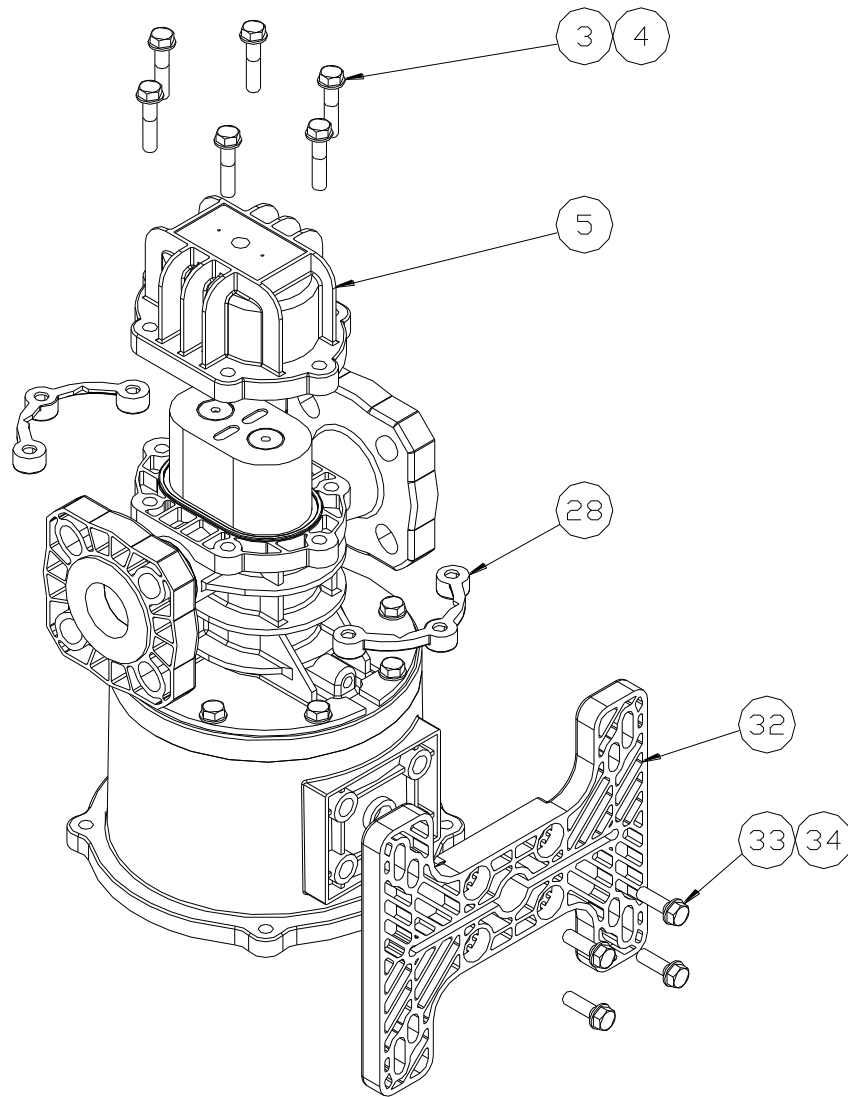

Figure 44

11. Secure the mounting base (item 32) to the motor spool (item 20) using the four bolts and washers (items 33, 34) as shown. Always tighten fasteners in a progressive “crisscross” pattern.

12. If it was removed, install the motor adaptor plate (item 18) onto the motor face using the four bolts and washers (items 29 and 30). Always tighten fasteners in a progressive “crisscross” pattern.

NOTE: E125 May use (2) Adaptor Plates, ref #18.

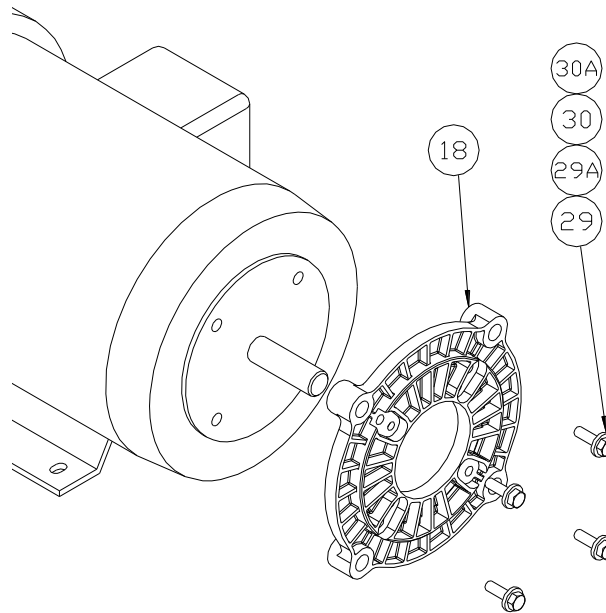

Figure 45

13. Secure the magnet hub (item 25) to the drive magnet (item 24) using the four screws (item 27). Always tighten fasteners in a progressive “crisscross” pattern.

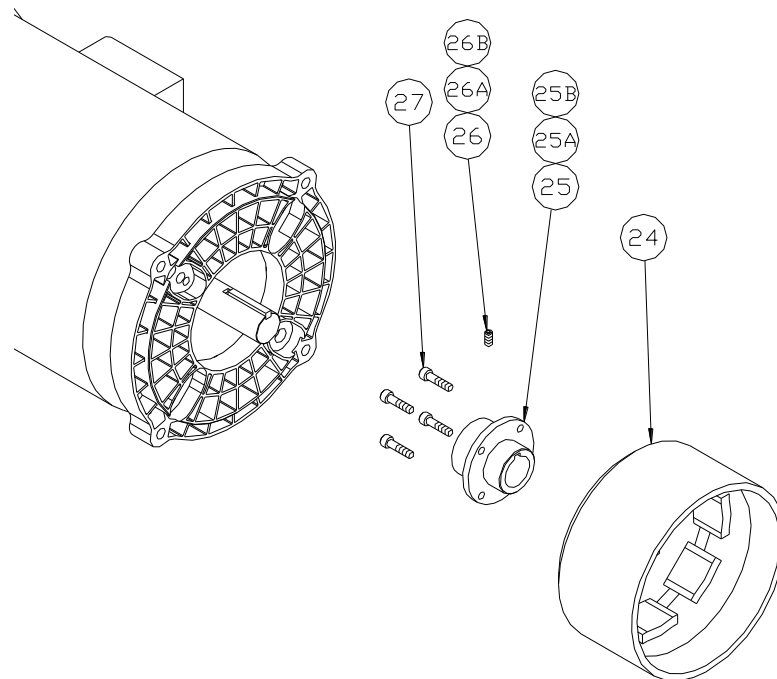

Figure 46



BE CAREFUL DURING DISASSEMBLY AND REASSEMBLY OF THE DRIVE AND DRIVEN MAGNET ASSEMBLIES. THE MAGNETIC ATTRACTION FORCES ARE HIGH, AND WHEN THE MAGNETS COME CLOSE TOGETHER THERE IS A STRONG TENDENCY TO SNAP TOGETHER SUDDENLY, POTENTIALLY CAUSING INJURY TO FINGERS OR FLESH.

14. Align the keyway, and slide the drive magnet onto the motor shaft until the end of the motor shaft aligns with faces of the drive magnet motor hub as shown below. Secure with the setscrew (item 26). Application of a no-seize compound on the shaft and key will make future maintenance easier.

15. Complete assembly by replacing the assembled pump onto the motor, using care not to allow fingers to get pinched when the magnets attract. Secure the pump to the motor with the four bolts and washers (items 22, 23). Always tighten fasteners in a progressive “crisscross” pattern.

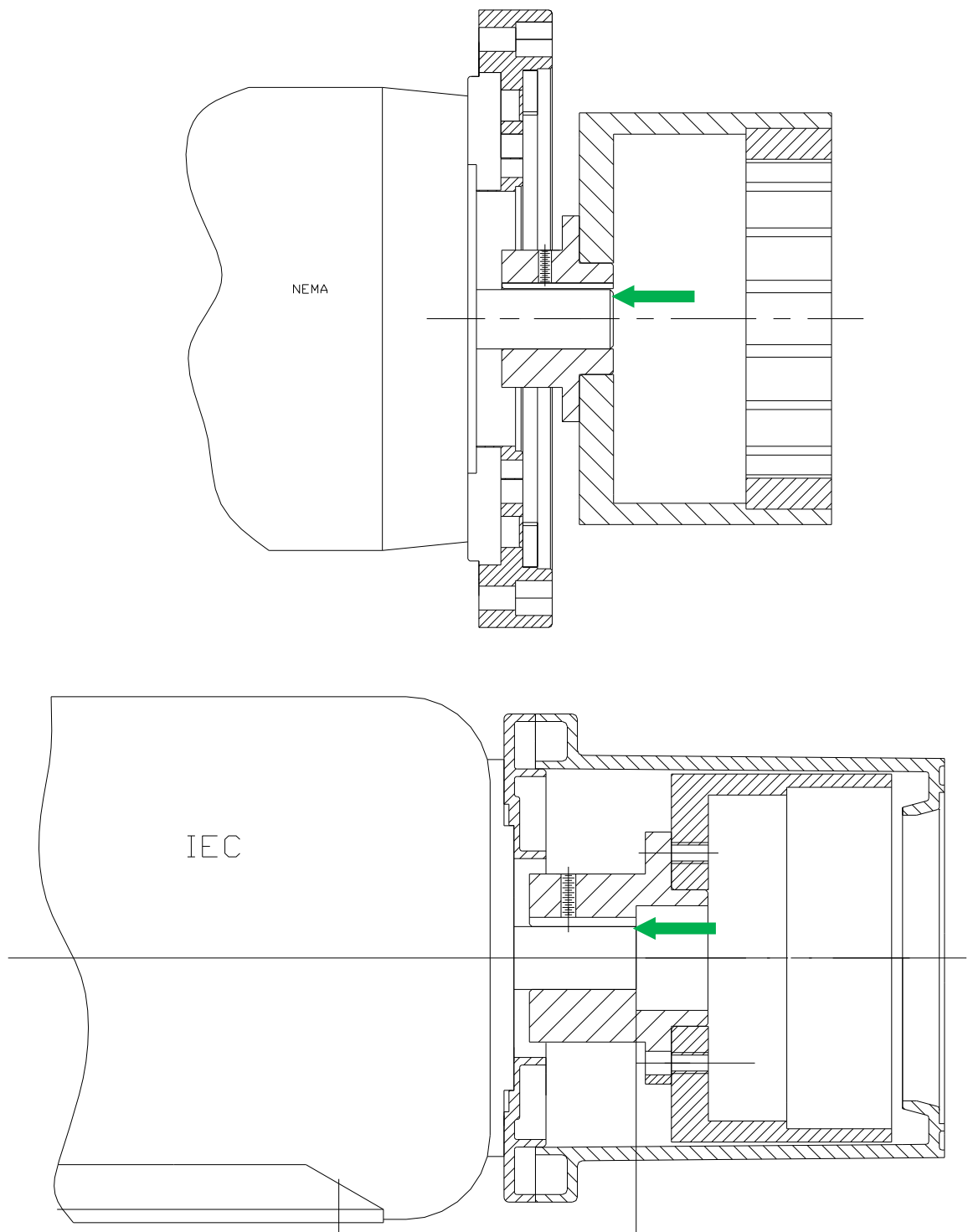

Figure 47

9. Inspection and Wear Limits

Inspect internal pump components as follows. See **Chart 9.1 for Service and Replacement Limits**.

Bearings

Inspect both bearing bores and end surfaces for wear and scoring. If wear or scoring is present on the end surface of the bearing, the bearing can be flipped to expose the undamaged face to the gear side. Bearings should be replaced when both ends show wear and/or scoring or when the bores have reached the replacement limit.

Shafts

Both the idler and the drive shaft should be inspected carefully for scoring, wear, and any signs of cracking or chips in the shaft surface. No cracks or chips are allowed. Shafts should be replaced if they show signs of cracks or chips anywhere on the surface, if they are deeply scored, or if they have reached their replacement limit.

Gears

Gears can be measured for dimensional change to their length and outside diameter. Gear teeth should also be visually inspected for wear and damage. Gear teeth can be damaged due to solids moving through the pump, which will affect only some teeth, or excessive pressure, which will distort the outside tips of all teeth. Gears that have reached their replacement limits or show signs of physical damage or distortion should be replaced. Backlash can be checked by temporarily inserting the two gear/shaft assemblies into known good bearings and observing gear tooth mesh and backlash.

Housing Liner

The housing liner should be visually inspected for scoring, wear, and steps on the inner diameter of the two gear bores. See chart for specific limits.



NOTE

The viscosity of the pumped product will affect the service limits of your Eclipse pump. Fluids with higher viscosities will usually be more tolerant of wear and allow longer maintenance intervals. Fluids with low viscosities will usually require more frequent maintenance, as they are less tolerant of clearances between the pump's internal surfaces. Regular inspection and detailed maintenance records will determine the optimal maintenance interval for each application.

9.1 Service and Replacement Limits

Part	Pump Model	New Spec Dimension	Serviceable Limit	Replacement Limit
Bearings	E02	ID 0.293" Length 0.499"	0.0025 bore wear end wear – flip over	0.005 bore wear both ends worn
	E05/E12	ID 0.439"	0.003 bore wear end wear – flip over	0.006 bore wear both ends worn
	E25	ID 0.627"	0.004 bore wear end wear – flip over	0.008 bore wear both ends worn
	E75/E125	ID 1.002"	0.005 bore wear end wear – flip over	0.010 bore wear both ends worn
Shafts	E02	OD 0.2916"	0.001 smooth wear	0.001 deep or rough scoring
	E05/E12	OD 0.437"		
	E25	OD 0.625"		
	E75/E125	OD 1.000"		
NOTE: Cracks or chips in shaft surface are not allowed				
Gears	E02	Length 0.4055" OD 0.600"	0.0005 wear – length 0.003 wear – OD 0.010 Backlash	0.001 wear – length 0.006 wear – OD 0.020 Backlash
	E05	Length 0.624" OD 1.063"	0.001 wear – length 0.004 wear – OD 0.015 Backlash	0.002 wear – length 0.008 wear – OD 0.030 Backlash
	E12	Length 1.249" OD 1.063"	Same as E05/EH05 above	Same as E05/EH05 above
	E25	Length 1.499" OD 1.417"	0.002 wear – length 0.005 wear – OD 0.020 Backlash	0.004 wear – length 0.010 wear – OD 0.040 Backlash
	E75	Length 1.998" OD 2.125"	0.003 wear – length 0.006 wear – OD 0.025 Backlash	0.006 wear – length 0.012 wear – OD 0.050 Backlash
	E125	Length 2.998" OD 2.125"		
Housing Liner	E02	n/a	0.002 wear or step	0.004 wear or step
	E05/E12	n/a	0.003 wear or step	0.006 wear or step
	E25	n/a	0.004 wear or step	0.008 wear or step
	E75/E125	n/a	0.005 wear or step	0.10 ar or step

10. Troubleshooting

Symptom	Probable Cause	Remedy
No Liquid Delivered	Pump not primed.	Prime pump. Ensure suction piping and any strainers are clean and clear of any obstructions.
	Motor incorrectly wired.	Check wiring diagram.
	Air leak in suction.	Locate and repair leak.
	Rotation direction incorrect.	Reverse motor wiring.
	Suction and/or discharge valves closed.	Open valves.
	Suction lift too high.	Do not exceed published limits.
	Magnetic coupling decoupled.	Stop motor, eliminate blockage or jamming and restart. If no blockage exists verify that operating conditions do not exceed capabilities of the pump.
	Drive magnet interference.	Adjust the drive magnet location on the motor shaft to not interfere with the casing/spool.
Low Liquid Delivery	Discharge head higher than calculated.	Reduce discharge restrictions e.g.: Open throttle valve or back-pressure valve.
	Air leak in suction.	Locate and repair leak.
	Rotational speed incorrect.	Check speed and wiring. Adjust as required.
	Suction pipe restrictions	Ensure suction valve is fully open and strainer is clean.
	Pressure relief valve open	Reset PRV to proper setting based on system pressure.
	Pump components worn.	Inspect and repair as required, see KOPkit details.
Low Discharge Pressure	Rotational speed incorrect.	Check speed and adjust as required.
	Air leak in suction.	Repair leak.
	Air or gas in liquid.	Eliminate air or gas that can be caused by obstructions in suction piping, leak in suction pipe, or cavitation and/or boiling of pumped fluid.
	Pump components worn	Inspect and repair as required, see KOPkit details.
Pump Gradually Loses Prime	Air pocket in suction line.	Eliminate pocket.
	Air entering suction line.	Keep suction inlet submerged at all times.
Pump Noisy	Pump worn or damaged.	Inspect and repair as required, see KOPkit details.
	Air or gas in liquid.	Eliminate air or gas. Check system piping for locations that may trap air or gas.
	Fasteners not properly torqued.	Inspect parts for damage. Re-install to proper torque in progressive “criss-cross” pattern.
	Drive magnet interference.	Adjust the drive magnet location on the motor shaft to not interfere with the casing/spool.

Pump Runs Hot	Excessive loading on the pump.	Reevaluate pump application. Check system monitoring devices are set properly.
	Driven magnet installed backwards.	Replace driven magnet and install in correct orientation.
Motor Runs Hot or Overloads	It is normal for motors to feel hot even when not overloaded.	Check the actual temperature of the motor housing with suitable instrumentation. Verify the figures with the motor manufacturer.
	Motor wired incorrectly.	Check wiring diagram.
	Voltage or frequency low.	Correct condition.
	Motor not sized correctly.	Higher pressures may require more power than the motor is capable. Consult performance curves.
	Heavy or viscous liquid being pumped.	Pumping fluids heavier or more viscous than water requires a properly sized, higher powered motors.
	Binding internal pump parts.	Inspect and correct condition.

11. Specifications

11.1 Eclipse 02 General Specifications	Non-Metallic	Metallic
Port Size and Type	¼ inch FNPT or BSPT	
Direction of Rotation	Bi-directional	
Maximum Differential Pressure	150 psig (10 bar, 1034 kPa)	
Maximum Allowable Working Pressure	200 psig (13.8 bar, 1379 kPa)	
Maximum Speed	1750 rpm	
Maximum Capacity at 0 psig	0.4 US gpm (1.5 lpm)	
Maximum Viscosity	1,000 cps	
Maximum Process Fluid Temperature	150 F (66 C) at maximum differential pressure	
Minimum Process Fluid Temperature	-40 F (-40 C)	
Fluid pH Range	0-14	
Gear Type	Compact Spur Gear Design	
Bearing Type	Sleeve Bearing Integral Wear Plate	Metallic Cartridge with Serviceable Bearing and Wear Plate
Magnetic Torque Rating	22 in-lbs. (2.5 N-m)	Consult Factory
Motor Frame Sizes - NEMA	56C and 143/145TC	56C
Motor Frame Sizes - IEC	63, 71, 80 B3/B14 Face	63 and 71 B3/B14 Face
Pump Housing Materials of Construction	Carbon Filled Modified PTFE	316L SS or Alloy C
Gear Materials of Construction	Modified PTFE	
Shaft Materials of Construction	Alumina Ceramic	316L SS or Alloy C
Can Materials of Construction	Kynar	316L SS or Alloy C
Magnet Materials of Construction	Neodymium Iron	
O-ring Seal Materials	Viton A, EPDM, or Kalrez	PTFE and Kalrez
Approximate Weight	3.6 lbs. (1.6 kg) less motor	Consult Factory

11.2 Eclipse 05 General Specifications	Non-Metallic	Metallic
Port Size and Type	3/8 inch FNPT or BSPT	½ inch FNPT or BSPT
Direction of Rotation	Bi-directional	
Maximum Differential Pressure	150 psig (10 bar, 1034 kPa)	
Maximum Allowable Working Pressure	200 psi (13.8 bar, 1379 kPa)	
Maximum Speed	1750 rpm	
Maximum Capacity at 0 psig	1.7 US gpm (6.3 lpm)	
Maximum Viscosity	10,000 cps	
Maximum Process Fluid Temperature	150 F (66 C) at maximum differential pressure	
Minimum Process Fluid Temperature	-40 F (-40 C)	
Fluid pH Range	0-14	
Gear Type	Compact Spur Gear Design	
Bearing Type	Sleeve Bearing Integral Wear Plate	Metallic Cartridge with Serviceable Bearing and Wear Plate
Magnetic Torque Rating	228 in-lbs. (25.7 N-m)	Consult Factory
Motor Frame Sizes - NEMA	56C, 143/145TC, 182C/184C	56C and 143/145TC
Motor Frame Sizes - IEC	63 and 80 B3/B14 Face	71 and 80 B3/B14 Face
Pump Housing Materials of Construction	Kynar	316L SS or Alloy C
Gear Materials of Construction	Modified PTFE	
Shaft Materials of Construction	Alumina Ceramic	316L SS or Alloy C
Can Materials of Construction	Kynar	316L SS or Alloy C
Magnet Materials of Construction	Neodymium Iron	
O-ring Seal Materials	Viton A, EPDM, or Kalrez	PTFE and Kalrez
Approximate Weight	8.9 lbs. (4.0 kg) less motor	Consult Factory

11.3 Eclipse 12 General Specifications	Non-Metallic	Metallic
Port Size and Type	¾ inch FNPT or BSPT	½ inch FNPT or BSPT
Direction of Rotation	Bi-directional	
Maximum Differential Pressure Carbon Bearing	100 psig (6.8 bar, 690 kPa)	
Maximum Differential Pressure SiC Bearing	150 psig (10 bar, 1034 kPa)	N/A
Maximum Allowable Working Pressure Carbon Brg and SiC Brg	200 psi (13.8 bar, 1379 kPa)	
Maximum Speed	1750 rpm	
Maximum Capacity at 0 psig	3.4 US gpm (12.9 lpm)	
Maximum Viscosity	10,000 cps	
Maximum Process Fluid Temperature	150 F (66 C) at maximum differential pressure	
Minimum Process Fluid Temperature	-40 F (-40 C)	
Fluid pH Range	0-14	
Gear Type	Compact Spur Gear Design	
Bearing Type	Sleeve Bearing Integral Wear Plate	Metallic Cartridge with Serviceable Bearing and Wear Plate
Magnetic Torque Rating	228 in-lbs. (25.7 N-m)	Consult Factory
Motor Frame Sizes - NEMA	56C, 143/145TC, 182C/184C	56C and 143/145TC
Motor Frame Sizes - IEC	63, 71, 80 B3/B14 Face	71 and 80 B3/B14 Face
Pump Housing Materials of Construction	Kynar	316L SS or Alloy C
Gear Materials of Construction	Modified PTFE	
Shaft Materials of Construction	Alumina Ceramic	316L SS or Alloy C
Can Materials of Construction	Kynar	316L SS or Alloy C
Magnet Materials of Construction	Neodymium Iron	
O-ring Seal Materials	Viton A, EPDM, or Kalrez	PTFE and Kalrez
Approximate Weight	10.0 lbs. (4.5 kg) less motor	Consult Factory

11.4 Eclipse 25 General Specifications	Non-Metallic	Metallic
Port Size and Type	1 inch ANSI 150# / DIN 20/25 Flanged	¾ inch NPT or BSPT
Direction of Rotation	Bi-directional	
Maximum Differential Pressure	150 psig (10 bar, 1034 kPa)	
Maximum Allowable Working Pressure	200 psi (13.8 bar, 1379 kPa)	
Maximum Speed	1750 rpm	
Maximum Capacity at 0 psig	7.4 US gpm (28.0 lpm)	
Maximum Viscosity	10,000 cps	
Maximum Process Fluid Temperature	150 F (66 C) at maximum differential pressure	
Minimum Process Fluid Temperature	-40 F (-40 C)	
Fluid pH Range	0-14	
Gear Type	Compact Spur Gear Design	
Bearing Type	Sleeve Bearing Integral Wear Plate	Metallic Cartridge with Serviceable Bearing and Wear Plate
Magnetic Torque Rating	474 in-lbs. (53.5 N-m)	Consult Factory
Motor Frame Sizes - NEMA	56C, 143/145TC, 182C/184C	56C and 143/145TC
Motor Frame Sizes - IEC	100/112 B3/B14 Face	80 and 90 B3/B14 Face
Pump Housing Materials of Construction	Kynar	316L SS or Alloy C
Gear Materials of Construction	Modified PTFE	
Shaft Materials of Construction	Alumina Ceramic	316L SS or Alloy C
Can Materials of Construction	Kynar	316L SS or Alloy C
Inner Magnet Materials of Construction	Neodymium Iron	
O-ring Seal Materials	Viton A, EPDM, or Kalrez	PTFE and Kalrez
Approximate Weight	26.0 lbs. (11.8 kg) less motor	Consult Factory

11.5 Eclipse 75 General Specifications	
Port Size and Type	1.5 inch ANSI 150# / DIN 32/40 Flanged
Direction of Rotation	Bi-directional
Theoretical Displacement	1.423 US gal / 100 rev. (53.9 cc / rev.)
Maximum Differential Pressure	150 psig (10 bar, 1034 kPa)
Maximum Allowable Working Pressure	200 psi (13.8 bar, 1379 kPa)
Maximum Speed	1750 rpm
Maximum Capacity at 0 psig	22 US gpm (83.3 lpm)
Maximum Viscosity	10,000 cps
Maximum Process Fluid Temperature	150 F (66 C) at maximum 125 psi differential pressure
Minimum Process Fluid Temperature	-40 F (-40 C)
Fluid pH Range	0-14
Gear Type	Compact Spur Gear Design
Bearing Type	Sleeve Bearing Integral Wear Plate
Magnetic Torque Rating	668 in-lbs. (75.4 N-m)
Motor Frame Sizes - NEMA	143/145TC and 182/184TC
Motor Frame Sizes - IEC	100/112 B14 Face
Pump Housing Materials of Construction	Kynar
Gear Materials of Construction	Modified PTFE
Can Materials of Construction	Kynar
Inner Magnet Materials of Construction	Neodymium Iron
O-ring Seal Materials	Viton A, EPDM, or Kalrez
Approximate Weight	43.7 lbs. (19.8 kg) less motor

11.6 Eclipse 125 General Specifications	
Port Size and Type	1.5 inch ANSI 150# / DIN 32/40 Flanged
Direction of Rotation	Bi-directional
Theoretical Displacement	2.135 US gal / 100 rev. (80.82 cc / rev.)
Maximum Differential Pressure Carbon Bearing	80 psig (5.5 bar, 552 kPa)
Maximum Differential Pressure SiC Bearing	100 psig (6.8 bar, 689 kPa)
Maximum Allowable Working Pressure Carbon Brg and SiC Brg	200 psi (13.8 bar, 1379 kPa)
Maximum Speed	1750 rpm
Maximum Capacity at 0 psig	33 US gpm (125 lpm)
Maximum Viscosity	10,000cps
Maximum Process Fluid Temperature	150 F (66 C) at maximum differential pressure
Minimum Process Fluid Temperature	-40 F (-40 C)
Fluid pH Range	0-14
Gear Type	Compact Spur Gear Design
Bearing Type	Sleeve Bearing Integral Wear Plate
Magnetic Torque Rating	668 in-lbs. (75.4 N-m)
Motor Frame Sizes - NEMA	143/145TC, 182/184TC, 213/215TC, 254/256TC
Motor Frame Sizes - IEC	100/112 B14 Face, 132 B14 Face
Pump Housing Materials of Construction	Kynar
Gear Materials of Construction	Modified PTFE
Can Materials of Construction	Kynar
Magnet Materials of Construction	Neodymium Iron
O-ring Seal Materials	Viton A, EPDM, or Kalrez
Approximate Weight	Approx. 44.7 lbs. (20.3 kg)

11.1 General Specifications – Non-Metallic

Maximum Sound Levels	
Pump Size	Sound Level (dB)
Eclipse 02	80
Eclipse 05	81
Eclipse 12	82
Eclipse 25	83
Eclipse 75	85
Eclipse 125	95

Maximum Flange Loads		
Pump Size	Flange Loads lb (N)	Flange Loads Ft-lb (N-m)
Eclipse 02	25 (111)	10 (13.5)
Eclipse 05	25 (111)	20 (27)
Eclipse 12	25 (111)	25 (33)
Eclipse 25	30 (133)	20 (27)
Eclipse 75, & 125	50 (222)	25 (34)

Maximum Suction Lift (Dry or Wetted Pump)	
Pump Size	Feet (m)
Eclipse 02	3 (0.9)
Eclipse 05	3 (0.9)
Eclipse 12	3 (0.9)
Eclipse 25	5 (1.5)
Eclipse 75, & 125	5 (1.5)

NPSH Required
NPSHr = 2 ft (0.6m) at 1750rpm – All Sizes

Vacuum Systems – Flooded Suction
Maximum vacuum of 28 in-Hg (14 psi- gauge) or 0.1mm Hg (Absolute)

Solids Handling Capability
Size: 70 Microns / 0.003 inches / 0.07 mm
Maximum Concentrations: 10%
200 Mesh strainer recommended

Consult factory for metallic pump general specifications.

11.2 Torque Specifications

Pump Size	Bolt Position		Bolt Size	Recommended Torque	
				in-lbs	N-m
<i>Eclipse 02</i>	Non-Metallic	Front Cover -to- Housing	10 - 32	15	1.7
	Metallic	Front Cover -to- Housing	8 – 32	20	2.3
	Non-Metallic	Housing Adaptor -to- Spool	1/4 - 20	48	4.5
	Metallic	Housing -to- Spool	3/8 - 16	40	4.5
	Spool -to- Motor Adaptor or Motor		3/8 - 16	72	8.1
	Motor Adaptor -to- Motor				
	56C		3/8 - 16	72	8.1
	63 B14		M5 - 0.80	24	2.7
	80 B14		M6 - 1.00	48	5.4
<i>Eclipse 05 and 12</i>	Non-Metallic	Front Cover -to- Housing	1/4 - 20	60	6.8
	Metallic	Front Cover -to- Housing	1/4 - 28	60	6.8
	Non-Metallic	Housing -to- Spool	1/4 - 20	60	6.8
	Metallic	Housing -to- Spool	1/4 - 28	60	6.8
	Spool -to- Motor Adaptor or Motor		3/8 - 16	72	8.1
	Motor Adaptor -to- Motor				
	56C		3/8 - 16	72	8.1
	143TC - 182C		3/8 - 16	72	8.1
	63 B14		M5 - 0.80	24	2.7
80 B14		M6 - 1.00	48	5.4	
<i>Eclipse 25</i>	Non-Metallic	Front Cover -to- Housing	1/4 - 20	72	8.1
	Metallic	Front Cover -to- Housing	1/4 - 28	60	6.8
	Non-Metallic	Housing -to- Spool	3/8 - 16	120	13.6
	Metallic	Housing -to- Spool	1/4 - 28	60	6.8
	Non-Metallic	Spool -to- Motor Adaptor	3/8 - 16	120	13.6
	Metallic	Spool -to- Motor Adaptor	1/4 - 28	60	6.8
	Base Mount -to- Spool		3/8 - 16	120	13.6
	Flange Bolts (min. to seal)		Varies	120	13.6
	Motor Adaptor -to- Motor				
	56C		3/8 - 16	72	8.1
	143TC - 182C		3/8 - 16	120	13.6
	100 - 112 B14		M8 - 1.25	120	13.6
<i>Eclipse 75 and 125</i>	Front Cover		3/8 - 16	120	13.6
	Housing -to- Spool		3/8 - 16	120	13.6
	Spool -to- Motor Adaptor		3/8 - 16	120	13.6
	Base Mount -to- Spool		3/8 - 16	120	13.6
	Flange Bolts (min. to seal)		Varies	120	13.6
	Motor Adaptor -to- Motor				
	143TC - 182C		3/8 - 16	120	13.6
	1182TC - 184TC		1/2 - 13	120	13.6
	2213TC - 215TC		1/2 - 13	120	13.6
	2254TC - 256TC		1/2 - 13	120	13.6
	1100 - 112 B14		M8 - 1.25	120	13.6
1132 B34		M8 - 1.25	120	13.6	

12. Pump Model Identification

Position	Code	Specifies	Options	Available Pump Size
1	E	Model	E – Eclipse	All
2 and 3	02, 05, 12, 25, 75, 125	Pump Size	02 – Max. Capacity .4 gpm (1.5 lpm) 05 – Max. Capacity 1.7 gpm (6.3 lpm) 12 – Max. Capacity 3.4 gpm (12.9 lpm) 25 – Max. Capacity 7.4 gpm (28.0 lpm) 75 – Max Capacity 22 gpm (83.3 lpm) 125 – Max Capacity 33 gpm (125 lpm)	See Options
4	K, M, N, A, G, C, J	Base Material	K – PVDF, FNPT M – PVDF, BSPT N – PVDF, FLANGED A – 316LSS, FNPT G – 316LSS, BSPT, ISO 7-1 C – ALLOY C, FNPT J – ALLOY C, BSPT, ISO 7-1	02, 05, 12 02, 05, 12 25, 75, 125 02, 05, 12, 25 02, 05, 12, 25 02, 05, 12, 25 02, 05, 12, 25
5	L, B	Bearings	L – Carbon-92 B – Silicon Carbide	All All
6	V, E, K, U	O-rings	V – Viton A E – EPDM K – Kalrez Grade 4079 U – PTFE	All All All All
7	F, O, R, W, H, J, K, L, P, Y	Motor Mounting	F – NEMA 56C O – NEMA 143/5TC-182/4C R – NEMA 182-184TC W – NEMA 213TC – 215TC H – IEC 63 B3/B14 J – IEC 71 B3/B14 K – IEC 80 B3/B14 L – IEC 90 B3/B14 P – IEC 100/112 B3/B14 Y – No Motor Mounting Kit	02, 05, 12, 25, 75 All 75, 125 75, 125 02, 05, 12 02, 05, 12 02, 05, 12, 25, 75 25, 75 25, 75, 125 All*
8	-		Dash	All
9	X, A, N, B,	Options	X – Complete Pump (No Options) A – Bearing Flush Port N – Pump Wet End Only B – Combination of “A” and “N” X-ATEX – Pump with ATEX Directive A-ATEX – Pump with ATEX Directive N-ATEX – Pump with ATEX Directive B-ATEX – Pump with ATEX Directive	All 05, 12, 25, 75, 125 All* 05, 12, 25, 75, 125 All 05, 12, 25, 75, 125 All 05, 12, 25, 75, 125

* Non-metallic pumps only:

Complete pump model number with position 7 code “Y” includes the drive magnet, non-metallic pumps only.

Option code “N” is only available in conjunction with position 7 code “Y.”

Consult factory for motor mounting details, option combinations not covered in the above chart, and export restrictions.
Consult factory regarding Eclipse Hypo pump model string configurations, example: EH12KBVO-X

12.1 KOPkit Part Number Identification

Position	Code	Specifies	Options
1	E	Model	E – Eclipse
2 and 3	02, 05, 12, 25, 75, 125	Pump Size	02 – Max. Capacity .4GPM (1.5LPM) 05 – Max. Capacity 1.3GPM (4.9LPM) 12 – Max. Capacity 3.2GPM (12.1LPM) 25 – Max. Capacity 6.5GPM (24.6LPM) 75 – Max Capacity 20GPM (75LPM) 125 – Max Capacity 33GPM (125LPM)
4	X, A, G, C, J	Base Material	X – Not Specified for Non-Metallic pumps A – 316LSS, FNPT G – 316LSS, BSPT, ISO 7-1 C – ALLOY C, FNPT J – ALLOY C, BSPT, ISO 7-1
5	L, B	Bearings	L – Carbon-92 B – Silicon Carbide
6	V, E, K, U	O-rings	V – Viton A E – EPDM K – Kalrez Grade 4079 U – PTFE
Suffix	-LTE, -STD -PRO	Kit Selection	-LTE – Liner, Gears, Cover O-ring -STD – Liner, Gears, Bearings, O-rings -PRO – Liner, Gears, Bearings, O-rings, Hardware

13. Parts Diagram and List, Eclipse 02 Non-metallic

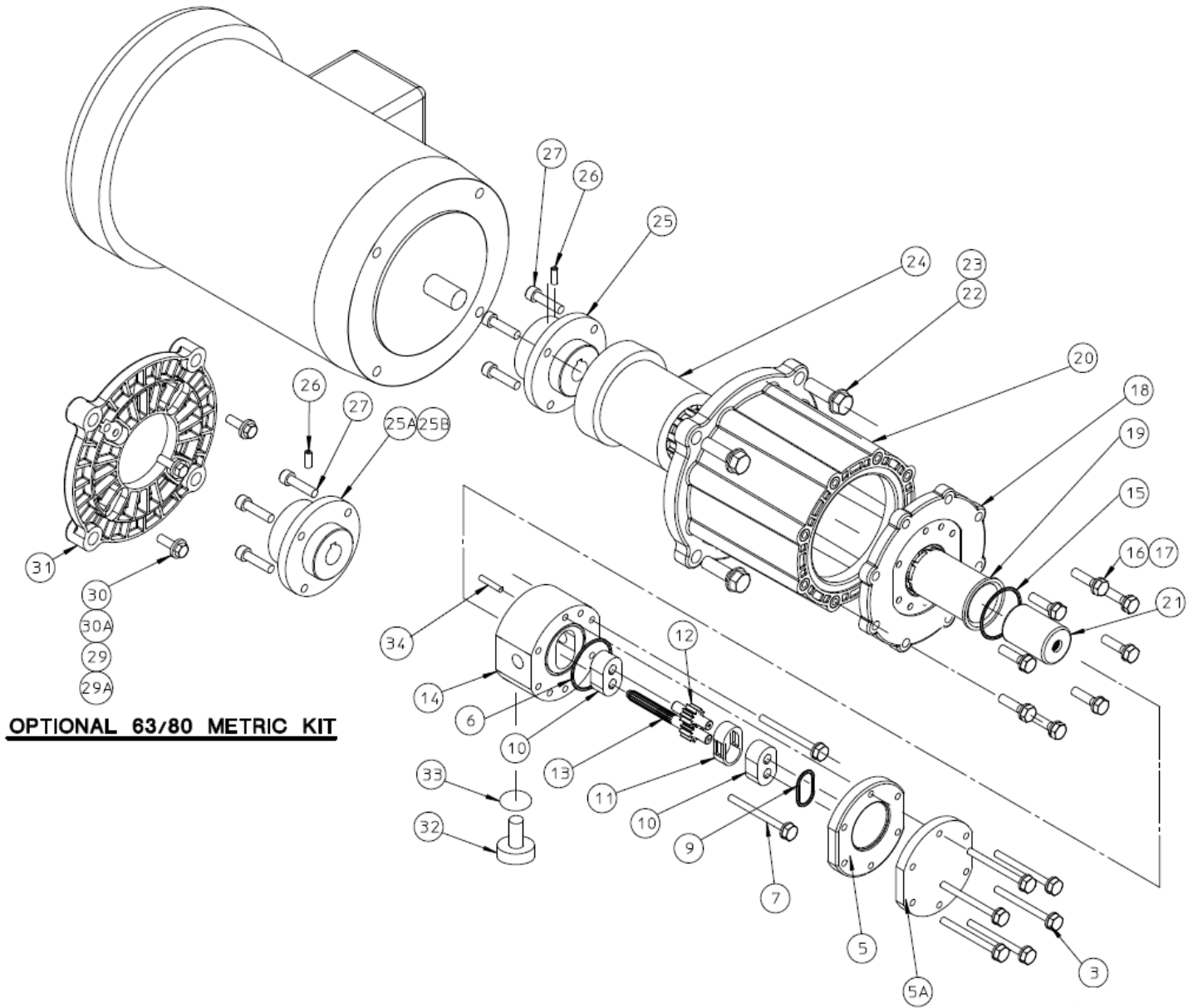

Eclipse Pump Series Size 02 Non-Metallic

Consolidated Bill of Material

Position 1,2,3,4 - Base Pump Material/Ports

(* Denotes recommended spares)

Position 4 Base Pump Material and Port Connection

PVDF
(K) or (M)

E02	Description	Item	Part Number:	Material	Qty
Common Parts	Screw	3	W770612-188	Stainless Steel	6
	Screw	7	W770611-188	Stainless Steel	2
	Name Plate	1	NG550003-304	Stainless Steel	1
	Can, Containment	19	NG210004-PVD	Carbon-filled PVDF	1
	Driven Magnet Assembly	21	NG200030-TEF	Neo / ETFE	1
	Drive Magnet	24	NG200034-STL	Neo / Steel	1
	Plate, Cover Reinforcement	5A	NG120011-188	Stainless Steel	1
	Adapter, Spool	20	NG110010-PET	Polyester	1
	Adapter, Can	18	NG110012-PET	Polyester	1
	Bolt	16	W770403-188	Stainless Steel	8
	Washer	17	NG990018-188	Stainless Steel	8
	Plug, Drain	32	NG990014-FTE	ETFE	1
	Roll Pin	34	W771206-002	Steel	1
	Cover, Front	5	NG020001-CTF	Carbon-filled PTFE	1
K	Housing, Center FNPT	14	NG040019-CTF	Carbon-filled PTFE	1
M	Housing, Center FBSPT		NG040020-CTF	Carbon-filled PTFE	

Position 5 - Bearing Materials

	Description	Item	Part Number:	Material	Qty
Common Parts	Liner, Housing *	11	NG220002-FTE	ETFE	1
	Gear Assembly, Drive *	13	NG010014-FTE	ETFE / ALA	1
	Gear Assembly, Idler *	12	NG010013-FTE	ETFE / ALA	1
L	Bearing *	10	NG080001-CBN	Carbon-92	2
B	Bearing *		NG080001-SIC	Silicon Carbide	

Position 6 - O-ring Material Selection

	Description	Item	Part Number:	Material	Qty
V	O-ring Containment Can *	15	W078452-VTN	Viton A	1
	O-ring Cover *	6	W078452-VTN	Viton A	1
	O-ring Compression *	9	NP440020-VTN	Viton A	1
	O-ring Drain Plug *	33	W059100-VTN	Viton A	1
	O-ring Containment Can *	15	W078452-N0R	EPDM	1
	O-ring Cover *	6	W078452-N0R	EPDM	1
	O-ring Compression *	9	NG440020-N0R	EPDM	1
	O-ring Drain Plug *	33	W059100-N0R	EPDM	1
	O-ring Containment Can *	15	NG440029-KLZ	Kalrez	1
	O-ring Cover *	6	NG440029-KLZ	Kalrez	1
	O-ring Compression *	9	NG440020-KLZ	Kalrez	1
	O-ring Drain Plug *	33	NG440012-KLZ	Kalrez	1

Position 7 - NEMA C-Face and IEC B34 Metric Frame Magnetic Coupling Arrangement

56C NEMA frame components		Item	Part Number:	Material	Qty
F	Coupling Hub	25	NG940002-STL	Steel	1
	Set Screw	26	W771004-031	Steel	1
	Bolt	22	W770425-188	Stainless Steel	4
	Washer	23	NG990019-188	Stainless Steel	4
	Screw	27	W770021-188	Stainless Steel	4
Motor Mount Kit #		E02XXXF			

63 IEC B34 frame components		Item	Part Number:	Material	Qty
H	Coupling Hub	25A	NG940004-STL	Steel	1
	Set Screw	26A	NP991004-017	Steel	1
	Adapter, Motor	31	NG110005-PET	Polyester	1
	Bolt	29	NP990418-188	Stainless Steel	4
	Washer	30	NP991016-188	Stainless Steel	4
	Bolt	22	W770426-188	Stainless Steel	4
	Washer	23	NG990019-188	Stainless Steel	4
	Screw	27	W770021-188	Stainless Steel	4
Motor Mount Kit #		E02XXXH			

71 IEC B34 frame components		Item	Part Number:	Material	Qty
J	Coupling Hub	25A	NG940011-STL	Steel	1
	Set Screw	26A	NG990027-188	Steel	1
	Adapter, Motor	31	NG110019-ALU	Aluminum	1
	Bolt	29	W770546-188	Stainless Steel	4
	Bolt	22	W770425-188	Stainless Steel	4
	Washer	23	NG990019-188	Stainless Steel	4
	Screw	27	W770021-188	Stainless Steel	4
Motor Mount Kit #		E02XXXJ			

80 IEC B34 frame components		Item	Part Number:	Material	Qty
K	Coupling Hub	25B	NG940005-STL	Steel	1
	Set Screw	26B	NP991004-001	Steel	1
	Adapter, Motor	31	NG110005-PET	Polyester	1
	Bolt	29A	W770546-188	Stainless Steel	4
	Washer	30A	NP991017-188	Stainless Steel	4
	Bolt	22	W770426-188	Stainless Steel	4
	Washer	23	NG990019-188	Stainless Steel	4
	Screw	27	W770021-188	Stainless Steel	4
Motor Mount Kit #		E02XXXK			

Consult factory for Position 9 Options

KOPkit Suffix Selection Bill of Materials

	Description	Item	Qty
-LTE	Liner, Housing	11	1
	Gear Assembly, Drive	13	1
	Gear Assembly, Liner	12	1
	O-ring Cover	6	1

	Description	Item	Qty
-STD	Bearing	10	2
	Liner, Housing	11	1
	Gear Assembly, Drive	13	1
	Gear Assembly, Liner	12	1
	O-ring Cover	6	1
	O-ring Compression	9	2

	Description	Item	Qty
-PRO	Bearing	10	2
	Liner, Housing	11	1
	Gear Assembly, Drive	13	1
	Gear Assembly, Liner	12	1
	O-ring Cover	6	1
	O-ring Compression	9	2
	Bolt	16	6

13.1 Parts Diagram and List, Eclipse 02 Metallic

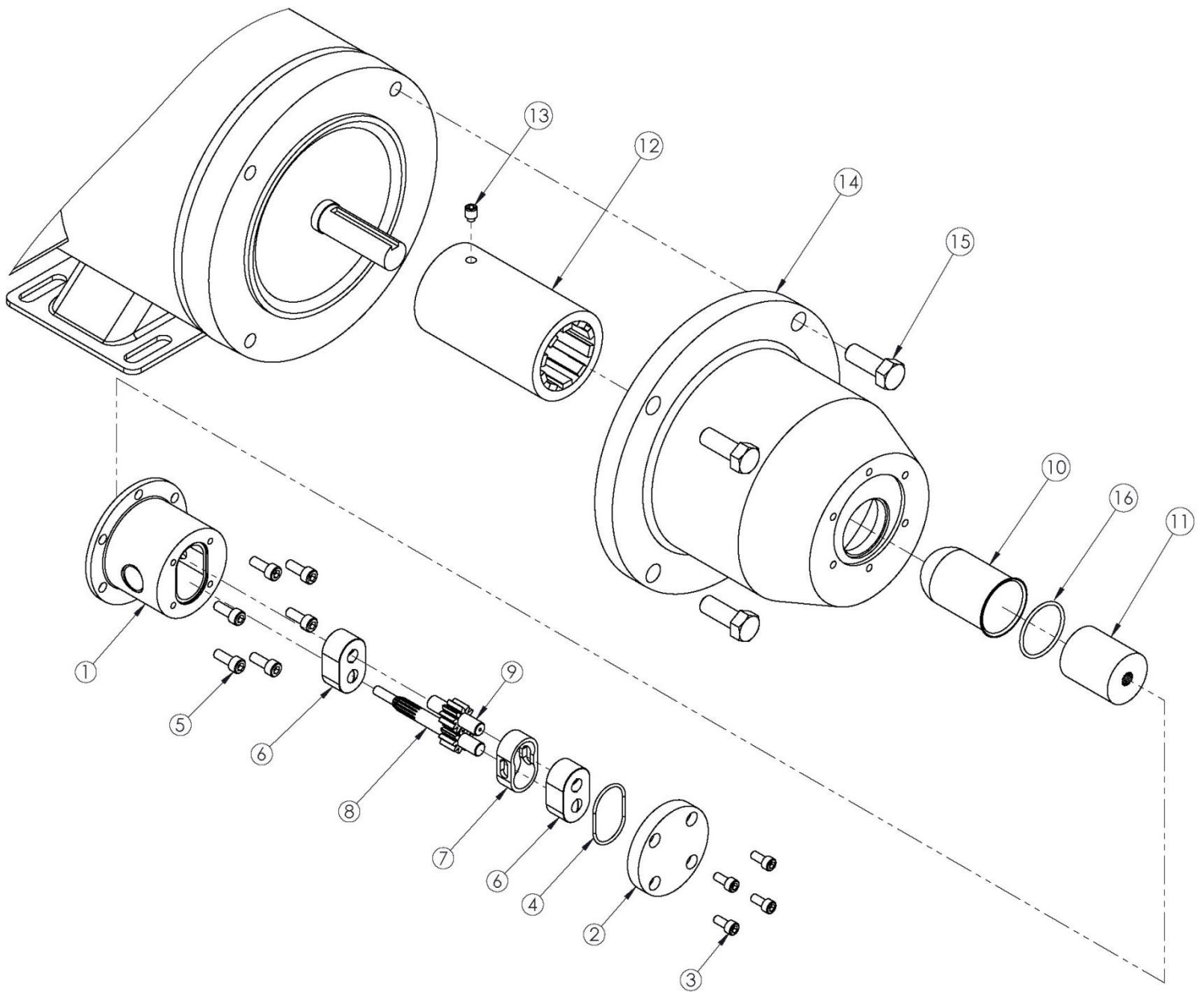

Eclipse Pump Series Size 02 Metallic

Consolidated Bill of Material

Position 1,2,3,4 - Base Pump Material/Ports

(* Denotes recommended spares)

			Position 4 Base Pump Material and Port Connection				
			316L SS (A or G)		Alloy C (C or J)		
E02	Description	Item	Part Number	Material	Part Number	Material	Qty
Common Parts	Screw	3	NP990555-188	Stainless Steel	NP990555-188	Stainless Steel	4
	Driven Magnet Assembly	11	NG200002-RYT	Stainless Steel	NG200002-RYT	Stainless Steel	1
	Cover	2	NG050001-316	Stainless Steel	NG050001-HC0	Alloy C	1
	Can, Containment	10	NG210001-316	Stainless Steel	NG210001-HC0	Alloy C	1
	Nameplate	N/S	NG550003-304	Stainless Steel	NG550003-304	Stainless Steel	1
	Drive Screw	N/S	W771000-188	Stainless Steel	W771000-188	Stainless Steel	2
A, C	Housing, Center FNPT	1	NG040050-316	Stainless Steel	NG040050-HC0	Alloy C	1
G, J	Housing, Center BSPT		NG040054-316	Stainless Steel	NG040054-HC0	Alloy C	1

Position 5 - Bearing Materials

			316L SS (A or G)		Alloy C (C or J)		
	Description	Item	Part Number	Material	Part Number	Material	Qty
Common Parts	Liner, Housing *	7	NG220002-FTE	ETFE	NG220002-FTE	ETFE	1
	Gear Assembly, Drive *	8	NG010001-316	Stainless Steel	NG010001-HC0	Alloy C	1
	Gear Assembly, Idler *	9	NG010013-FTE	Ryton / 316 SS	NG010013-FTE	Ryton / Alloy C	1
L	Bearing *	6	NG080001-CBN	Carbon 92	NG080001-CBN	Carbon 92	2
B	Bearing *	6	NG080001-SIC	Silcon Carbide	NG080001-SIC	Silicon Carbide	2

Position 6 - O-ring Material Selection

	Description	Item	Part Number	Material	Qty
U	O-ring Containment Can	16	W078419-TFE	PTFE	1
	O-ring Cover	4	W078419-TFE	PTFE	1

Position 7 - NEMA C-Face and IEC B3/14 Metric Frame Magnetic Coupling Arrangement

56C NEMA frame components

	Description	Item	Part Number	Material	Qty
F	Motor Adaptor 56C	14	NG110001-000	Aluminum	1
	Drive Magnet Assembly	12	NG200010-000	Stainless Steel	1
	Bolt	15	W770425-188	Stainless Steel	4
	Screw	5	W770010-188	Stainless Steel	6
	Set Screw	13	W771004-116	Stainless Steel	1
Motor Mount Kit#	E02XXUF				

63 IEC B3/14 frame components

	Description	Item	Part Number	Material	Qty
H	Motor Adaptor 63 IEC	14	NG110003-000	Aluminum	1
	Drive Magnet Assembly	12	NG200014-000	Stainless Steel	1
	Bolt	15	NP990479-STL	Steel	4
	Screw	5	W770010-188	Stainless Steel	6
	Set Screw	13	NP991004-001	Steel	6
Motor Mount Kit#	E02XXUH				

71 IEC B3/14 frame components

	Description	Item	Part Number	Material	Qty
J	Motor Adaptor 71 IEC	14	NG110004-000	Aluminum	1
	Drive Magnet Assembly	12	NG200015-000	Stainless Steel	1
	Bolt	15	NP990482-188	Stainless Steel	4
	Screw	5	W770010-188	Stainless Steel	6
	Set Screw	13	NP991004-001	Steel	6
	Motor Mount Kit#	E02XXUJ			

Consult factory for Position 9 Options

KOPkit Suffix Selection Bill of Materials

	Description	Item	Qty
-LTE	Liner, Housing	7	1
	Gear Assembly, Drive	8	1
	Gear Assembly, Idler	9	1
	Oring Cover	16	1

	Description	Item	Qty
-STD	Liner, Housing	7	1
	Gear Assembly, Drive	8	1
	Gear Assembly, Idler	9	1
	Bearing	6	2
	Oring Cover	16	1

Eclipse Pump Series Size 05 Non-Metallic

Consolidated Bill of Material

Position 1,2,3,4 - Base Pump Material/Ports

(* Denotes recommended spares)

Position 4 Base Pump Material and Port Connection	
PVDF (K) or (M)	

E05	Description	Item	Part Number	Material	Qty
Common Parts	Bolt	3	W770404-188	Stainless Steel	6
	Washer	4	NG990018-188	Stainless Steel	6
	Plate, Nut	28	NG990009-188	Stainless Steel	2
	Cover, Front	5	NG020002-PVD	Carbon-filled PVDF	1
	Bolt	16	W770403-188	Stainless Steel	8
	Washer	17	NG990018-188	Stainless Steel	8
	Name Plate	1	NG550003-304	Stainless Steel	1
	Drive Screw	2	W771000-188	Stainless Steel	2
	Can, Containment	19	NG210005-PVD	Carbon-filled PVDF	1
	Driven Magnet Assembly	21	NG200031-TEF	Neo / ETFE	1
	Drive Magnet	24	NG200035-STL	Neo / Steel	1
	Plate, Cover Reinforcement	5A	NG120012-188	Stainless Steel	1
	Adapter, Spool	20	NG110010-PET	Polyester	1
	Plug, Drain	34	NG990014-FTE	ETFE	1
	Plate, Reinforcement	32	NG120006-188	Stainless Steel	2
K	Housing, Center FNPT	14	NG040021-PVD	Carbon-filled PVDF	1
M	Housing, Center BSPT		NG040022-PVD	Carbon-filled PVDF	

Position 5 - Bearing Materials

	Description	Item	Part Number	Material	Qty
Common Parts	Liner, Housing *	11	NG220003-FTE	ETFE	1
	Gear Assembly, Drive *	13	NG010016-FTE	ETFE / ALA	1
	Gear Assembly, Idler *	12	NG010015-FTE	ETFE / ALA	1
L	Bearing *	10	NG080002-CBN	Carbon-92	2
B	Bearing *		NG080002-SIC	Silicon Carbide	

Position 6 - O-ring Material Selection

	Description	Item	Part Number	Material	Qty
V	O-ring Containment Can *	15	NG440154-VTA	Viton A	1
	O-ring Cover *	6	NG440137-VTA	Viton A	1
	O-ring Drain Plug *	33	W059100-VTN	Viton A	1
	O-ring Compression *	9	NG440129-VTA	Viton A	1
E	O-ring Containment Can *	15	NG440154-N0R	EPDM	1
	O-ring Cover *	6	NG440137-N0R	EPDM	1
	O-ring Drain Plug *	33	W059100-N0R	EPDM	1
	O-ring Compression *	9	NG440129-N0R	EPDM	1
K	O-ring Containment Can *	15	NG440154-KLZ	Kalrez	1
	O-ring Cover *	6	NG440137-KLZ	Kalrez	1
	O-ring Drain Plug *	33	NG440012-KLZ	Kalrez	1
	O-ring Compression *	9	NG440129-KLZ	Kalrez	1

Position 7 - NEMA C-Face and IEC B34 Metric Frame Magnetic Coupling Arrangement

56C NEMA frame components		Item	Part Number	Material	Qty
F	Coupling Hub	25	NG940002-STL	Steel	1
	Set Screw	26	W771004-031	Steel	1
	Bolt	22	W770425-188	Stainless Steel	4
	Washer	23	NG990019-188	Stainless Steel	4
	Screw	27	W770021-188	Stainless Steel	4
Motor Mount Kit #		E05XXXF			

143TC - 182C NEMA frame components		Item	Part Number	Material	Qty
O	Coupling Hub	25	NG940003-STL	Steel	1
	Set Screw	26	W771004-031	Steel	1
	Bolt	22	W770425-188	Stainless Steel	4
	Washer	23	NG990019-188	Stainless Steel	4
	Screw	27	W770021-188	Stainless Steel	4
Motor Mount Kit #		E05XXXO			

63 IEC B34 frame components		Item	Part Number	Material	Qty
H	Coupling Hub	25A	NG940004-STL	Steel	1
	Set Screw	26A	NP991004-017	Steel	1
	Adapter, Motor	31	NG110005-PET	Polyester	1
	Bolt	29	NP990418-188	Stainless Steel	4
	Washer	30	NP991016-188	Stainless Steel	4
	Bolt	22	W770426-188	Stainless Steel	4
	Washer	23	NG990019-188	Stainless Steel	4
	Screw	27	W770021-188	Stainless Steel	4
Motor Mount Kit #		E05XXXH			

71 IEC B34 frame components		Item	Part Number	Material	Qty
J	Coupling Hub	25A	NG940011-STL	Steel	1
	Set Screw	26A	NG990027-188	Steel	1
	Adapter, Motor	31	NG110019-ALU	Aluminum	1
	Bolt	29	W770546-188	Stainless Steel	4
	Bolt	22	W770425-188	Stainless Steel	4
	Washer	23	NG990019-188	Stainless Steel	4
	Screw	27	W770021-188	Stainless Steel	4
Motor Mount Kit #		E05XXXJ			

80 IEC B34 frame components		Item	Part Number	Material	Qty
K	Coupling Hub	25B	NG940005-STL	Steel	1
	Set Screw	26B	NP991004-001	Steel	1
	Adapter, Motor	31	NG110005-PET	Polyester	1
	Bolt	29A	W770546-188	Stainless Steel	4
	Washer	30A	NP991017-188	Stainless Steel	4
	Bolt	22	W770426-188	Stainless Steel	4
	Washer	23	NG990019-188	Stainless Steel	4
	Screw	27	W770021-188	Stainless Steel	4
Motor Mount Kit #		E05XXXK			

Consult factory for Position 9 Options

KOPkit Suffix Selection Bill of Materials

-LTE	Description	Item	Qty
	Liner, Housing	11	1
	Gear Assembly, Drive	13	1
	Gear Assembly, Liner	12	1
	O-ring Cover	6	1

-STD	Description	Item	Qty
	Bearing	10	2
	Liner, Housing	11	1
	Gear Assembly, Drive	13	1
	Gear Assembly, Liner	12	1
	O-ring Cover	6	1
	O-ring Compression	9	2

-PRO	Description	Item	Qty
	Bearing	10	2
	Liner, Housing	11	1
	Gear Assembly, Drive	13	1
	Gear Assembly, Liner	12	1
	O-ring Cover	6	1
	O-ring Compression	9	2
	Bolt	3	6
	Washer	4	6
	Plate, Nut	28	2

14.1 Parts Diagram and List, Eclipse 05 Metallic

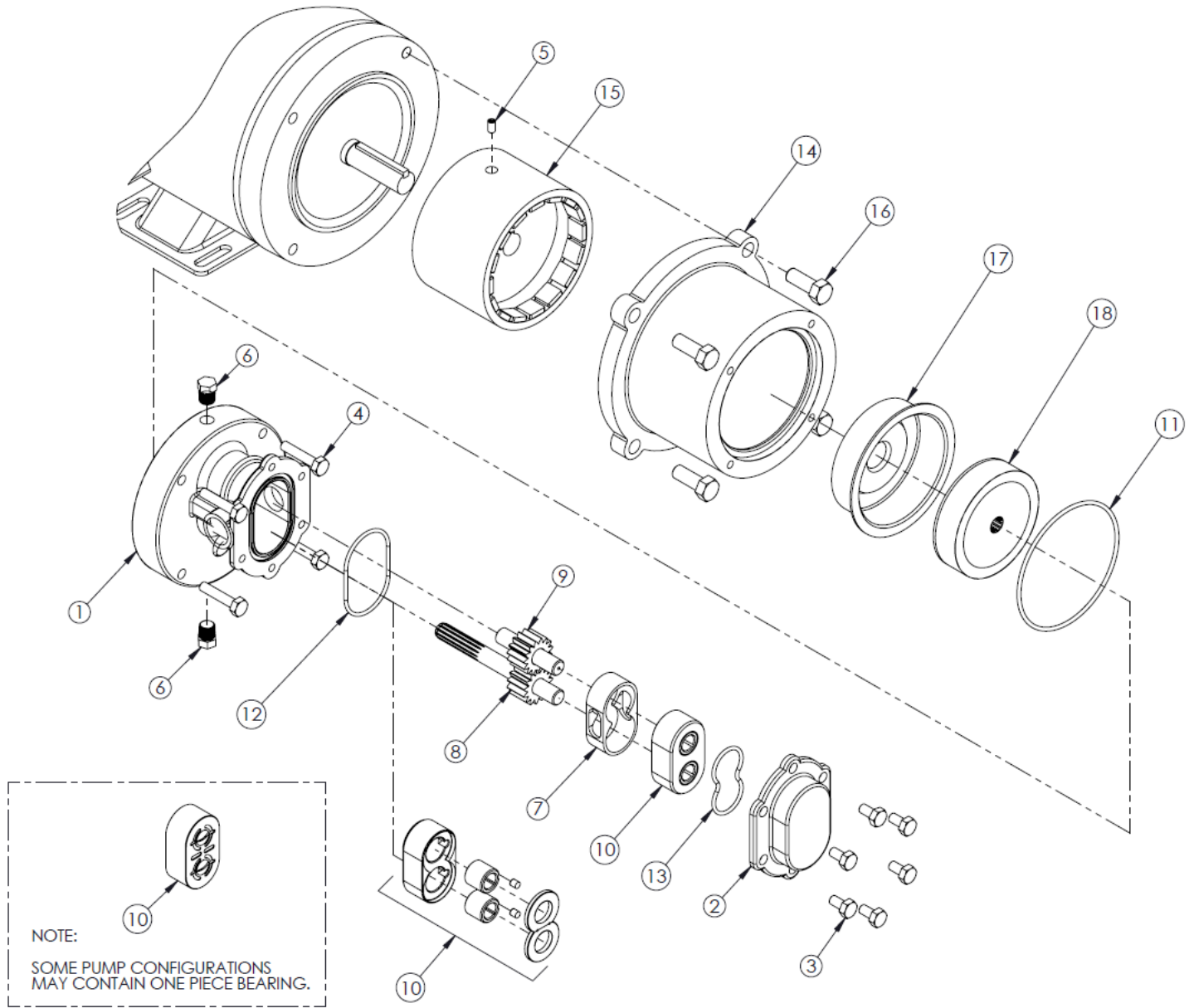

Eclipse Pump Series Size 05 Metallic

Consolidated Bill of Material

Position 1,2,3,4 - Base Pump Material/Ports

(* Denotes recommended spares)

			Position 4 Base Pump Material and Port Connection				
			316L SS (A or G)		Alloy C (C or J)		
E05	Description	Item	Part Number	Material	Part Number	Material	Qty
Common Parts	Bolt	3	NP990556-188	Stainless Steel	NP990556-188	Stainless Steel	6
	Screw	4	NP990557-188	Stainless Steel	NP990557-188	Stainless Steel	4
	Set Screw	5	W771004-019	Stainless Steel	W771004-019	Stainless Steel	1
	Nameplate	N/S	NG550003-304	Stainless Steel	NG550003-304	Stainless Steel	1
	Drive Screw	N/S	W771000-188	Stainless Steel	W771000-188	Stainless Steel	2
	Plug, Drain	6	W772565-316	Stainless Steel	W772565-HC0	Alloy C	2
	Driven Magnet Assembly	18	NG200065-316	Stainless Steel	NG200067-HC0	Alloy C	1
	Can, Containment	17	79672	Stainless Steel	79631	Alloy C	1
	Cover, Front	2	NG020018-316	Stainless Steel	NG020018-HC0	Alloy C	1
A, C	Housing, Center FNPT	1	NG040049-316	NG040049-316	NG040049-HC0	Alloy C	1
G, J	Housing, Center BSPT		NG040049-316	Stainless Steel	NG040049-HC0	Alloy C	1

Position 5 - Bearing Materials

			316L SS (A or G)		Alloy C (C or J)		
Common Parts	Description	Item	Part Number	Material	Part Number	Material	Qty
	Liner, Housing *	7	NG220003-FTE	ETFE	NG220003-FTE	ETFE	1
L	Gear Assembly, Drive *	8	NG010032-FTE	ETFE / 316L SS	NG010038-FTE	ETFE / Alloy C	1
	Gear Assembly, Idler *	9	NG010031-FTE	ETFE / 316L SS	NG010037-FTE	ETFE / Alloy C	1
	Bearing, Housing *	10	NG080012-316	Stainless Steel	NG080012-HC0	Stainless Steel	2
	Pin, Bearing Lock *		41801	PTFE	41801	PTFE	4
	Wear Plate *		NG220009-CBN	Carbon 92	NG220009-CBN	Carbon 92	4
	Bearing *		NG080011-000	Carbon 92	NG080011-000	Carbon 92	4
B	Gear Assembly, Drive *	8	NG010039-FTE	ETFE / ALA	NG010039-FTE	ETFE / ALA	1
	Gear Assembly, Idler *	9	NG010015-FTE	ETFE / ALA	NG010015-FTE	ETFE / ALA	1
	Bearing *	10	NG080002-SIC	Silicon Carbide	NG080002-SIC	Silicon Carbide	2

Position 6 - O-ring Material Selection

	Description	Item	Part Number	Material	Qty
U	O-ring Containment Can	11	W209787-TFE	PTFE	1
	O-ring Cover	12	NP440137-TFE	PTFE	1
	O-ring Compression	13	NG440129-KLZ	Kalrez	1

Position 7 - NEMA C-Face and IEC B3/14 Metric Frame Magnetic Coupling Arrangement

56C NEMA frame componets

	Description	Item	Part Number	Material	Qty
F	Casing	14	79610	Aluminum	1
	Drive Magnet Assembly	15	79684	Stainless Steel	1
	Bolt	16	W770425-STL	Steel	4
Motor Mount Kit #	E05XXUF				

143-145TC NEMA frame components

O	Description	Item	Part Number	Material	Qty
	Casing	14	79610	Aluminum	1
	Drive Magnet Assembly	15	79685	Stainless Steel	1
	Bolt	16	W770425-STL	Steel	4
Motor Mount Kit #	E05XXUO				

71 IEC B3/14 frame components

J	Description	Item	Part Number	Material	Qty
	Casing 71 IEC	14	79681	Aluminum	1
	Drive Magnet Assembly	15	79686	Stainless Steel	1
	Motor Adaptor 71 IEC	N/S	79679	Steel	1
	Bolt	N/S	16722	Steel	4
	Bolt	16	NP990415-STL	Steel	4
Motor Mount Kit #	E05XXUJ				

80 IEC B3/14 frame components

K	Description	Item	Part Number	Material	Qty
	Casing 80 IEC	14	79681	Aluminum	1
	Drive Magnet Assembly	15	79687	Stainless Steel	1
	Motor Adaptor 80 IEC	N/S	79680	Steel	1
	Bolt	N/S	16722	Steel	4
	Bolt	16	NP990415-STL	Steel	4
Motor Mount Kit #	E05XXUK				

Consult factory for Position 9 Options

KOPkit Suffix Selection Bill of Materials

-LTE	Description	Item	Qty
	Liner, Housing	7	1
	Gear Assembly, Drive	8	1
	Gear Assembly, Idler	9	1
	O-ring Cover	12	1

-STD	Description	Item	Qty
	Liner, Housing	7	1
	Gear Assembly, Drive	8	1
	Gear Assembly, Idler	9	1
	Bearing, Housing	10	1
	Pin, Bearing Lock		2
	Wear Plate		2
	Bearing		2
	O-ring Cover	12	1
	O-ring Compression	13	1

15. Parts Diagram and List, Eclipse 12 Non-Metallic

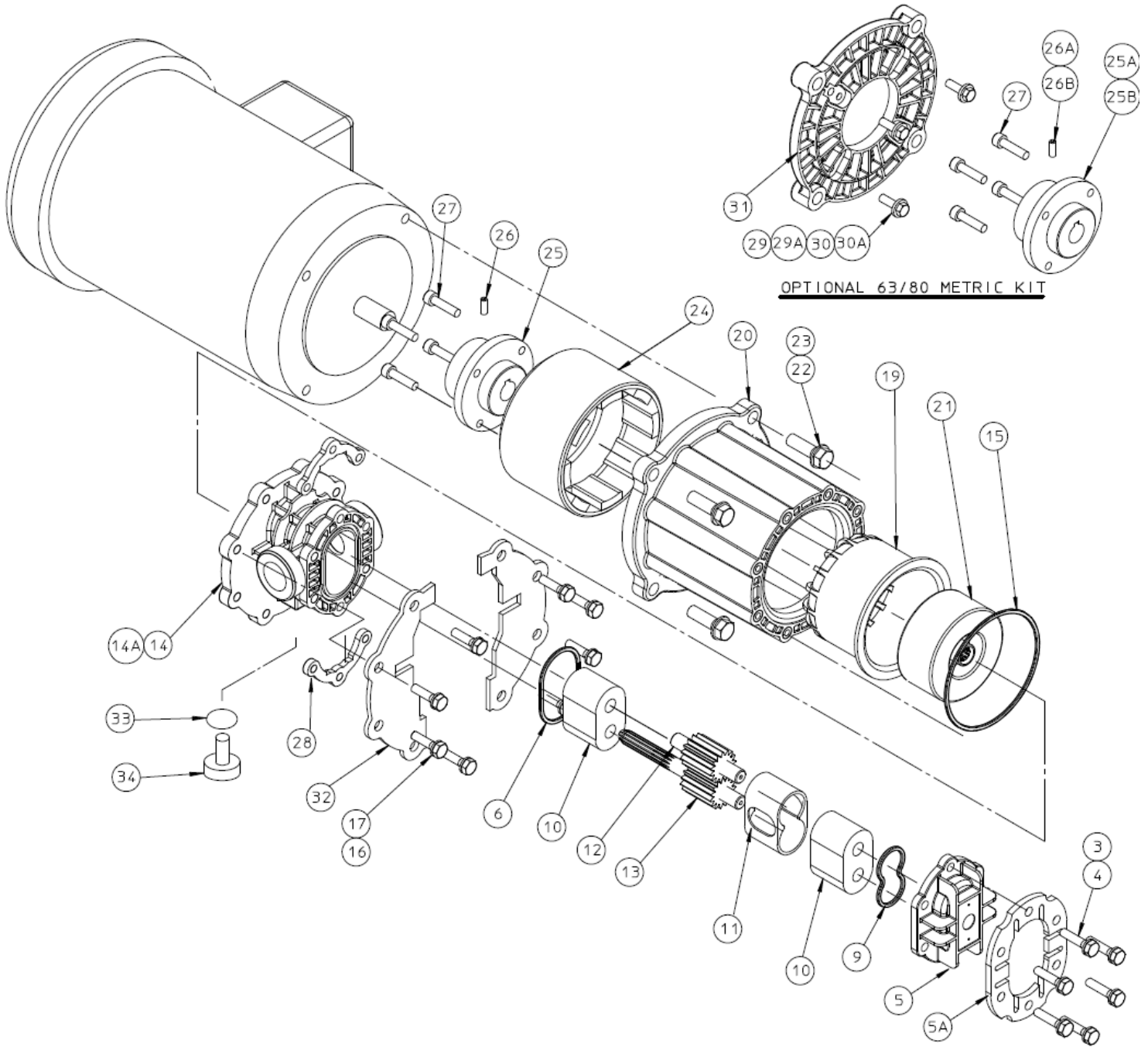

Eclipse Pump Series Size 12 Non-Metallic

Consolidated Bill of Material

Position 1,2,3,4, - Base Pump Material/Ports

(* Denotes recommended spares)

Position 4 Base Pump Material and Port Connection

PVDF
(K) or (M)

E12	Description	Item	Part Number:	Material	Qty
Common Parts	Bolt	3	W770404-188	Stainless Steel	6
	Washer	4	NG990018-188	Stainless Steel	6
	Plate, Nut	28	NG990009-188	Stainless Steel	2
	Bolt	16	W770403-188	Stainless Steel	8
	Washer	17	NG990018-188	Stainless Steel	8
	Name Plate	1	NG550003-304	Stainless Steel	1
	Drive Screw	2	W771000-188	Stainless Steel	2
	Can, Containment	19	NG210005-PVD	Carbon-filled PVDF	1
	Driven Magnet Assembly	21	NG200031-TEF	Neo / ETFE	1
	Drive Magnet	24	NG200035-STL	Neo / Steel	1
	Plate, Cover Reinforcement	5A	NG120012-188	Stainless Steel	1
	Adapter, Spool	20	NG110010-PET	Polyester	1
	Plug, Drain	34	NG990014-FTE	ETFE	1
	Cover, Front	5	NG020002-PVD	Carbon-filled PVDF	1
	Plate, Reinforcement	32	NG120006-188	Stainless Steel	2
K	Housing, Center FNPT	14	NG040028-PVD	Carbon-filled PVDF	1
M	Housing, Center BSPT		NG040028-PVD	Carbon-filled PVDF	

Position 6 - Bearing Materials

	Description	Item	Part Number:	Material	Qty
Common Parts	Liner, Housing *	11	NG220006-FTE	ETFE	1
	Gear Assembly, Drive *	13	NG010022-FTE	ETFE / ALA	1
	Gear Assembly, Idler *	12	NG010021-FTE	ETFE / ALA	1
L	Bearing *	10	NG08002-CBN	Carbon-92	2
B	Bearing *		NG080002-SIC	Silicon Carbide	

Position 7 - O-ring Material Selection

	Description	Item	Part Number:	Material	Qty
V	O-ring Containment Can *	15	NG440154-VTA	Viton A	1
	O-ring Cover *	6	NG440137-VTA	Viton A	1
	O-ring Drain Plug *	33	NG440012-VTA	Viton A	1
	O-ring Compression *	9	NG440129-VTA	Viton A	1
E	O-ring Containment Can *	15	NG440154-N0R	EPDM	1
	O-ring Cover *	6	NG440137-N0R	EPDM	1
	O-ring Drain Plug *	33	W059100-N0R	EPDM	1
	O-ring Compression *	9	NG440129-N0R	EPDM	1
K	O-ring Containment Can *	15	NG440154-KLZ	Kalrez	1
	O-ring Cover *	6	NG440137-KLZ	Kalrez	1
	O-ring Drain Plug *	33	NG440012-KLZ	Kalrez	1
	O-ring Compression *	9	NG440129-KLZ	Kalrez	1

Position 8 - NEMA C-Face and IEC B34 Metric Frame Magnetic Coupling Arrangement

56C NEMA frame components		Item	Part Number:	Material	Qty
F	Coupling Hub	25	NG940002-STL	Steel	1
	Set Screw	26	W771004-031	Steel	1
	Bolt	22	W770425-188	Stainless Steel	4
	Washer	23	NG990019-188	Stainless Steel	4
	Screw	27	W770021-188	Stainless Steel	4
Motor Mount Kit #		E12XXXF			

143TC - 182C NEMA frame components		Item	Part Number:	Material	Qty
O	Coupling Hub	25	NG940003-STL	Steel	1
	Set Screw	26	W771004-031	Steel	1
	Bolt	22	W770425-188	Stainless Steel	4
	Washer	23	NG990019-188	Stainless Steel	4
	Screw	27	W770021-188	Stainless Steel	4
Motor Mount Kit #		E12XXXO			

63 IEC B34 frame components		Item	Part Number:	Material	Qty
H	Coupling Hub	25A	NG940004-STL	Steel	1
	Set Screw	26A	NP991004-017	Steel	1
	Adapter, Motor	31	NG110005-PET	Polyester	1
	Bolt	29	NP990418-188	Stainless Steel	4
	Washer	30	NP991016-188	Stainless Steel	4
	Bolt	22	W770426-188	Stainless Steel	4
	Washer	23	NG990019-188	Stainless Steel	4
	Screw	27	W770021-188	Stainless Steel	4
Motor Mount Kit #		E12XXXH			

71 IEC B34 frame components		Item	Part Number:	Material	Qty
J	Coupling Hub	25A	NG940011-STL	Steel	1
	Set Screw	26A	NG990027-188	Steel	1
	Adapter, Motor	31	NG110019-ALU	Aluminum	1
	Bolt	29	W770546-188	Stainless Steel	4
	Bolt	22	W770426-188	Stainless Steel	4
	Washer	23	NG990019-188	Stainless Steel	4
	Screw	27	W770021-188	Stainless Steel	4
Motor Mount Kit #		E12XXXJ			

80 IEC B34 frame components		Item	Part Number:	Material	Qty
K	Coupling Hub	25B	NG940005-STL	Steel	1
	Set Screw	26B	NP991004-001	Steel	1
	Adapter, Motor	31	NG110005-PET	Polyester	1
	Bolt	29A	W770546-188	Stainless Steel	4
	Washer	30A	NP991017-188	Stainless Steel	4
	Bolt	22	W770426-188	Stainless Steel	4
	Washer	23	NG990019-188	Stainless Steel	4
	Screw	27	W770021-188	Stainless Steel	4
Motor Mount Kit #		E12XXXK			

Consult factory for Position 9 Options

KOPkit Suffix Selection Bill of Materials

-LTE	Description	Item	Qty
	Liner, Housing	11	1
	Gear Assembly, Drive	13	1
	Gear Assembly, Liner	12	1
	O-ring Cover	6	1

-STD	Description	Item	Qty
	Bearing	10	2
	Liner, Housing	11	1
	Gear Assembly, Drive	13	1
	Gear Assembly, Liner	12	1
	O-ring Cover	6	1
	O-ring Compression	9	2

-PRO	Description	Item	Qty
	Bearing	10	2
	Liner, Housing	11	1
	Gear Assembly, Drive	13	1
	Gear Assembly, Liner	12	1
	O-ring Cover	6	1
	O-ring Compression	9	2
	Bolt	3	6
	Washer	4	6
	Plate, Nut	28	2

15.1 Parts Diagram and List, Eclipse 12 Metallic

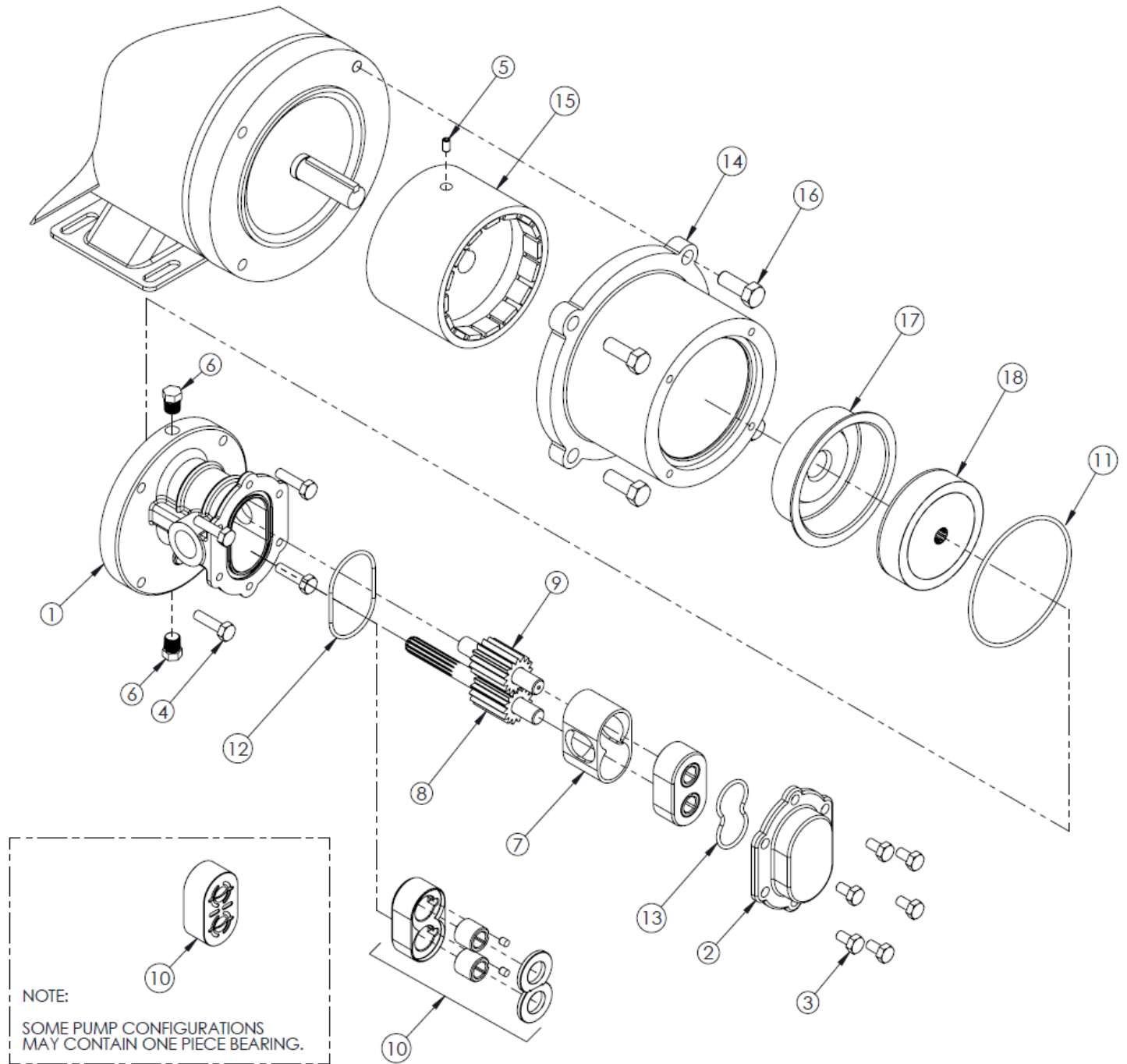

Eclipse Pump Series Size 12 Metallic

Consolidated Bill of Material

Position 1,2,3,4 - Base Pump Material/Ports

(* Denotes recommended spares)

E12	Description	Item	Position 4 Base Pump Material and Port Connection				Qty
			316L SS (A or G)		Alloy C (C orJ)		
			Part Number	Material	Part Number	Material	
Common Parts	Bolt	3	NP990556-188	Stainless Steel	NP990556-188	Stainless Steel	6
	Screw	4	NP990558-188	Stainless Steel	NP990558-188	Stainless Steel	4
	Set Screw	5	W771004-019	Stainless Steel	W771004-019	Stainless Steel	1
	Nameplate	N/S	NG550003-304	Stainless Steel	NG550003-304	Stainless Steel	1
	Drive Screw	N/S	W771000-188	Stainless Steel	W771000-188	Stainless Steel	2
	Plug, Drain	6	W772565-316	Stainless Steel	W772565-HC0	Stainless Steel	2
	Driven Magnet Assembly	18	NG200065-316	Stainless Steel	NG200067-HC0	Stainless Steel	1
	Can, Containment	17	79672	Stainless Steel	79631	Alloy C	1
	Cover, Front	17	NG020018-316	Stainless Steel	NG020018-HC0	Alloy C	1
A, C	Housing, Center FNPT	1	NG040048-316	Stainless Steel	NG040048-HC0	Alloy C	1
G, J	Housing, Center BSPT		NG040048-316	Stainless Steel	NG040048-HC0	Alloy C	1

Position 5 - Bearing Materials

Common Parts	Description	Item	316L SS (A or G)		Alloy C (C orJ)		Qty
			Part Number	Material	Part Number	Material	
	Liner, Housing *	7	NG220006-FTE	ETFE	NG220006-FTE	ETFE	1
L	Gear Assembly, Drive *	8	NG010029-FTE	ETFE / 316L SS	NG010036-FTE	ETFE / Alloy C	1
	Gear Assembly, Idler *	9	NG010030-FTE	ETFE / 316L SS	NG010035-FTE	ETFE / Alloy C	1
	Bearing, Housing	10	NG080012-316	Stainless Steel	NG080012-HC0	Alloy C	2
	Pin, Bearing Lock		41801	PTFE	41801	PTFE	4
	Wear Plate *		NG220009-CBN	Carbon 92	NG220009-CBN	Carbon 92	4
	Bearing *		NG080011-000	Carbon 92	NG080011-000	Carbon 92	4
B	Gear Assembly, Drive *	8	NG010040-FTE	ETFE / ALA	NG010040-FTE	ETFE / ALA	1
	Gear Assembly, Idler *	9	NG010021-FTE	ETFE / ALA	NG010021-FTE	ETFE / ALA	1
	Bearing *	10	NG080002-SIC	Silicon Carbide	NG080002-SIC	Silicon Carbide	2

Position 6 - O-ring Material Selection

U	Description	Item	Part Number	Material	Qty
	O-ring Containment Can	11	W209787-TFE	PTFE	1
	O-ring Cover	12	NP440137-TFE	PTFE	1
	O-ring Compression	13	NG440129-KLZ	Kalrez	1

Position 7 - NEMA C-Face and IEC B3/14 Metric Frame Magnetic Coupling Arrangement

56C NEMA frame components

F	Description	Item	Part Number	Material	Qty
	Casing	14	79610	Aluminum	1
	Drive Magnet Assembly	15	79684	Stainless Steel	1
	Bolt	16	W770425-STL	Steel	4
Motor Mount Kit #	E12XXUF				

143-145TC NEMA frame components

	Description	Item	Part Number	Material	Qty
O	Casing	14	79610	Aluminum	1
	Drive Magnet Assembly	15	79685	Stainless Steel	1
	Bolt	16	W770425-STL	Steel	4
Motor Mount Kit #	E12XXUO				

71 IEC B34 frame components

	Description	Item	Part Number	Material	Qty
J	Casing 71 IEC	14	79681	Aluminum	1
	Drive Magnet Assembly	15	79686	Stainless Steel	1
	Motor Adaptor 71 IEC	N/S	79679	Steel	1
	Bolt	N/S	16722	Steel	4
	Bolt	16	NP990415-STL	Steel	4
Motor Mount Kit #	E12XXUJ				

80 IEC B34 frame components

	Description	Item	Part Number	Material	Qty
K	Casing 80 IEC	14	79681	Aluminum	1
	Drive Magnet Assembly	15	79687	Stainless Steel	1
	Motor Adaptor 80 IEC	N/S	79680	Steel	1
	Bolt	N/S	16722	Steel	4
	Bolt	16	NP990415-STL	Steel	4
Motor Mount Kit #	E12XXUK				

Consult factory for Position 9 Options

KOPkit Suffix Selection Bill of Materials

	Description	Item	Qty
-LTE	Liner, Housing	7	1
	Gear Assembly, Drive	8	1
	Gear Assembly, Idler	9	1
	O-ring Cover	12	1

	Description	Item	Qty
-STD	Liner, Housing	7	1
	Gear Assembly, Drive	8	1
	Gear Assembly, Idler	9	1
	Bearing, Housing	10	1
	Pin, Bearing Lock		2
	Wear Plate		2
	Bearing		2
	O-ring Cover	12	1
	O-ring Compression	13	1

16. Parts Diagram and List, Eclipse 25 Non-Metallic

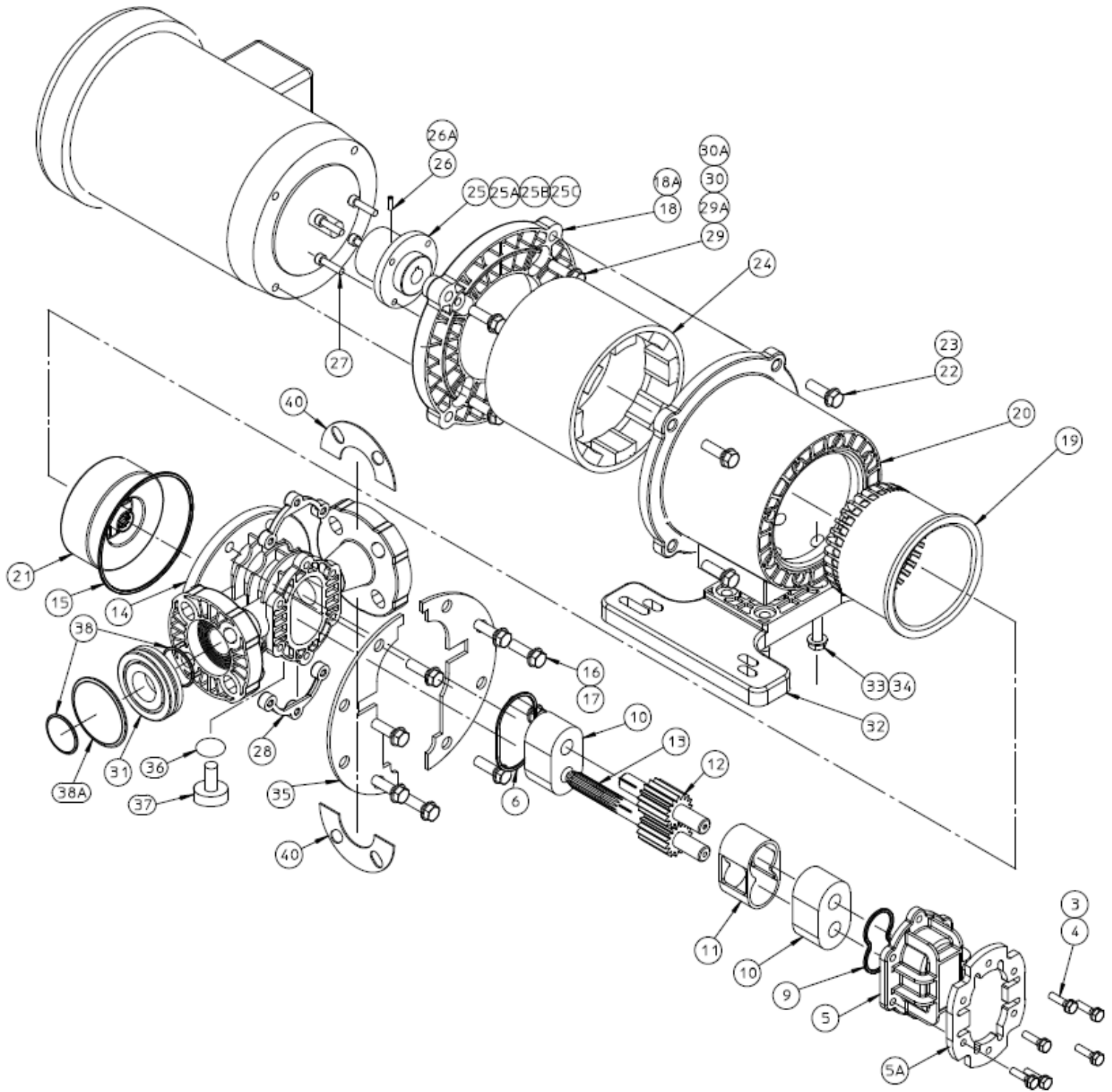

Eclipse Pump Series Size 25 Non-Metallic

Consolidated Bill of Material

Position 1,2,3,4 - Base Pump Material/Port (* Denotes recommended spares)			Position 4 Base Pump Material and Port Connection		
			PVDF Flanged (N)		
E25	Description	Item	Part Number:	Material	Qty
Common Parts	Bolt	3	W770405-188	Stainless Steel	6
	Washer	4	NG990018-188	Stainless Steel	6
	Plate, Nut	28	NG990010-188	Stainless Steel	2
	Plate, Reinforcement	35	NG120007-188	Stainless Steel	2
	Bolt	16	W770426-188	Stainless Steel	8
	Washer	17	NG990019-188	Stainless Steel	8
	Name Plate	1	NG550003-304	Stainless Steel	1
	Drive Screw	2	W771000-188	Stainless Steel	2
	Can, Containment	19	NG210006-PVD	Carbon filled PVDF	1
	Driven Magnet Assembly	21	NG200032-TEF	Neo / ETFE	1
	Drive Magnet	24	NG200036-STL	Neo / Steel	1
	Adapter, Spool	20	NG110009-ALU	Aluminum	1
	Base	32	NG970001-PET	Polyester	1
	Bolt	33	W770425-188	Stainless Steel	4
	Washer	34	NG990019-188	Stainless Steel	4
	Drain Plug	37	NG990014-FTE	ETFE	1
	Plate, Cover Reinforcement	5A	NG120013-188	Stainless Steel	1
	Plate, Flange Reinforcement	40	NG120010-188	Stainless Steel	4
	N	Housing, Center Flanged	14	NG040023-PVD	Carbon filled PVDF
Cover, Front		5	NG020003-PVD	Carbon filled PVDF	1

Position 6 - Bearing Materials

	Description	Item	Part Number:	Material	Qty
Common Parts	Liner, Housing *	11	NG220004-FTE	ETFE	1
	Gear Assembly, Drive *	13	NG010018-FTE	ETFE / ALA	1
	Gear Assembly, Idler *	12	NG010017-FTE	ETFE / ALA	1
L	Bearing *	10	NG080003-CBN	Carbob-92	2
B	Bearing *		NG080003-SIC	Silicon Carbide	

Position 7 - O-ring Material Selection

	Description	Item	Part Number:	Material	Qty
V	O-ring Containment Can *	15	NG440158-VTA	Viton A	1
	O-ring Cover *	6	NG440147-VTA	Viton A	1
	O-ring Drain Plug *	36	NG440012-VTA	Viton A	1
	O-ring Compression *	9	NG440138-VTA	Viton A	1
	Kit, Flange Gasket	31	NG450001-VTN	TFE / Viton A	2
E	O-ring Containment Can *	15	NG440158-N0R	EPDM	1
	O-ring Cover *	6	NG440147-N0R	EPDM	1
	O-ring Drain Plug *	36	W059100-N0R	EPDM	1
	O-ring Compression *	9	NG440138-N0R	EPDM	1
	Kit, Flange Gasket	31	NG450001-N0R	TFE / EPDM	2
K	O-ring Containment Can	15	NG440158-KLZ	Kalrez	1
	O-ring Containment Can *	6	NG440147-KLZ	Kalrez	1
	O-ring Cover *	36	NG440012-KLZ	Kalrez	1
	O-ring Drain Plug *	9	NG440138-KLZ	Kalrez	1
	Kit, Flange Gasket	31	NG450001-KLZ	TFE / Kalrez	2

Position 8 - NEMA C-Face and IEC B34 Metric Frame Magnetic Coupling Arrangement

56C NEMA frame components		Item	Part Number:	Material	Qty
F	Coupling Hub	25	NG940002-STL	Steel	1
	Adaptor, Motor	18	NG110006-PET	Polyester	1
	Set Screw	26	W771004-031	Steel	1
	Bolt	29	W770425-188	Stainless Steel	4
	Washer	30	NG990019-188	Stainless Steel	4
	Bolt	22	W770426-188	Stainless Steel	4
	Washer	23	NG990019-188	Stainless Steel	4
	Screw	27	W770021-188	Stainless Steel	4
Motor Mount Kit #	E25XXXF				

143TC - 182C NEMA frame components		Item	Part Number:	Material	Qty
O	Coupling Hub	25	NG940003-STL	Steel	1
	Adaptor, Motor	18	NG110006-PET	Polyester	1
	Set Screw	26	W771004-031	Steel	1
	Bolt	29	W770425-188	Stainless Steel	4
	Washer	30	NG990019-188	Stainless Steel	4
	Bolt	22	W770426-188	Stainless Steel	4
	Washer	23	NG990019-188	Stainless Steel	4
	Screw	27	W770021-188	Stainless Steel	4
Motor Mount Kit #	E25XXXO				

100/112 IEC B34 frame components		Item	Part Number:	Material	Qty
P	Coupling Hub	25A	NG940006-STL	Steel	1
	Adaptor, Motor	18	NG110006-PET	Polyester	1
	Set Screw	26A	NP991004-018	Steel	1
	Bolt	29A	W770534-188	Stainless Steel	4
	Washer	30A	NP991018-188	Stainless Steel	4
	Bolt	22	W770426-188	Stainless Steel	4
	Washer	23	NG990019-188	Stainless Steel	4
	Screw	27	W770021-188	Stainless Steel	4
Motor Mount Kit #	E25XXXP				

80 IEC B34 frame components		Item	Part Number:	Material	Qty
K	Coupling Hub 80	25A	NG940005-STL	Steel	1
	Adaptor, Motor	26A	NG110020-ALU	Aluminum	1
	Set Screw	26A	NP991004-001	Steel	1
	Bolt	29A	NP999121-188	Stainless Steel	4
	Washer	30A	NP991017-188	Stainless Steel	4
	Bolt	22	W770426-188	Stainless Steel	4
	Washer	23	NG990019-188	Stainless Steel	4
	Screw	27	W770021-188	Stainless Steel	4
Motor Mount Kit #	E25XXXK				

90 IEC B34 frame components		Item	Part Number:	Material	Qty
L	Coupling Hub 90	25A	NG940013-STL	Steel	1
	Adaptor	26A	NG110020-ALU	Aluminum	1
	Set Screw	26A	NP991004-018	Steel	1
	Bolt	29A	NP999004-188	Stainless Steel	4
	Washer	30A	NP991018-188	Stainless Steel	4
	Bolt	22	W770426-188	Stainless Steel	4
	Washer	23	NG990019-188	Stainless Steel	4
	Screw	27	W770021-188	Stainless Steel	4
Motor Mount Kit #	E25XXXL				

Consult factory for Position 9 Options

KOPkit Suffix Selection Bill of Materials

-LTE	Description	Item	Qty
	Liner, Housing	11	1
	Gear Assembly, Drive	13	1
	Gear Assembly, Liner	12	1
	O-ring Cover	6	1

-STD	Description	Item	Qty
	Bearing	10	2
	Liner, Housing	11	1
	Gear Assembly, Drive	13	1
	Gear Assembly, Liner	12	1
	O-ring Cover	6	1
O-ring Compression	9	2	

-PRO	Description	Item	Qty
	Bearing	10	2
	Liner, Housing	11	1
	Gear Assembly, Drive	13	1
	Gear Assembly, Liner	12	1
	O-ring Cover	6	1
	O-ring Compression	9	2
	Bolt	3	6
	Washer	4	6
	Plate, Nut	28	2

16.1 Parts Diagram and List, Eclipse 25 Metallic

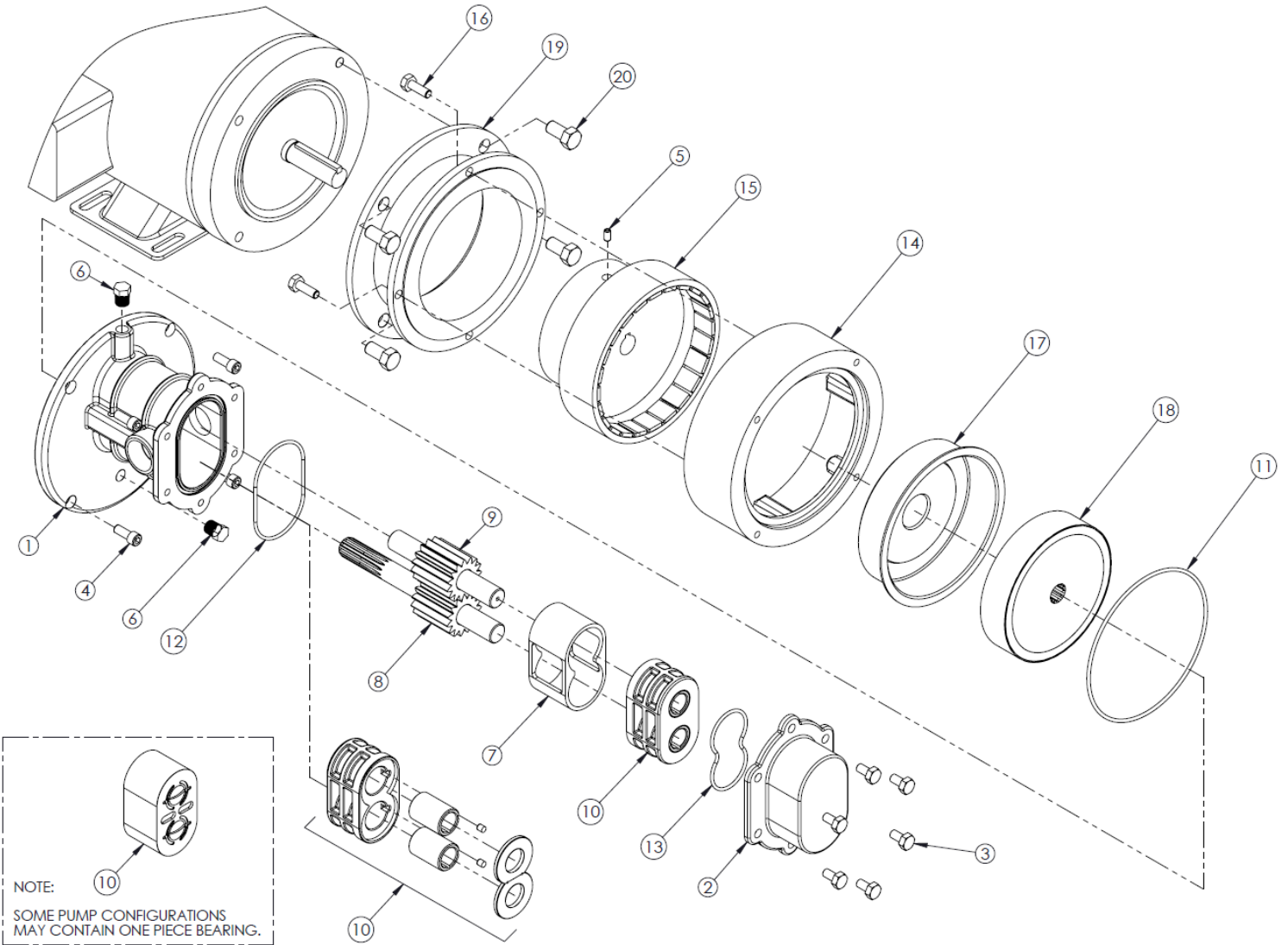

Eclipse Pump Series Size 25 Metallic

Consolidated Bill of Material

Position 1,2,3,4 - Base Pump Material/Ports

(* Denotes recommended spares)

			Position 4 Base Pump Material and Port Connection				Qty
			316L SS (A or G)		Alloy C (C orJ)		
E25	Description	Item	Part Number	Material	Part Number	Material	Qty
Common Parts	Bolt	3	NP990556-188	Stainless Steel	NP990556-188	Stainless Steel	6
	Screw	4	W770198-188	Stainless Steel	W770198-188	Stainless Steel	4
	Set Screw	5	W771004-019	Stainless Steel	W771004-019	Stainless Steel	1
	Nameplate	N/S	NG550003-304	Stainless Steel	NG550003-304	Stainless Steel	1
	Drive Screw	N/S	W771000-188	Stainless Steel	W771000-188	Stainless Steel	2
	Plug, Drain	6	W772565-316	Stainless Steel	W772565-HC0	Stainless Steel	2
	Driven Magnet Assembly	18	NG200063-316	Stainless Steel	NG200066-HC0	Alloy C	1
	Can, Containment	17	49672	Stainless Steel	49605	Alloy C	1
	Cover, Front	2	NG020017-316	Stainless Steel	NG020017-HC0	Alloy C	1
A, C	Housing, Center FNPT	1	NG040047-316	Stainless Steel	NG040047-HC0	Alloy C	1
G, J	Housing, Center BSPT	1	NG040053-316	Stainless Steel	NG040053-HC0	Alloy C	

Position 5 - Bearing Materials

			316L SS (A or G)		Alloy C (C orJ)		Qty
Common Parts	Description	Item	Part Number	Material	Part Number	Material	
	Liner, Housing *	7	NG220004-FTE	ETFE	NG220004-FTE	ETFE	1
L	Gear Assembly, Drive *	8	NG010028-FTE	ETFE / 316L SS	NG010034-FTE	ETFE / Alloy C	1
	Gear Assembly, Idler *	9	NG010027-FTE	ETFE / 316L SS	NG010033-FTE	ETFE / Alloy C	1
	Bearing, Housing *	10	NG080008-316	Stainless Steel	NG080008-HC0	Stainless Steel	2
	Pin, Bearing Lock *		41801	PTFE	41801	PTFE	4
	Wear Plate*		NG220008-CBN	Carbon 92	NG220008-CBN	Carbon 92	4
	Bearing *		NG080010-000	Carbon 92	NG080010-000	Carbon 92	4
B	Gear Assembly, Drive *	8	NG010041-FTE	ETFE / ALA	NG010041-FTE	ETFE / ALA	1
	Gear Assembly, Idler *	9	NG010017-FTE	ETFE / ALA	NG010017-FTE	ETFE / ALA	1
	Bearing *	10	NG080003-SIC	Silicon Carbide	NG080003-SIC	Silicon Carbide	2

Position 6 - O-ring Material Selection

	Description	Item	Part Number	Material	Qty
U	O-ring Containment Can	11	W209729-TFE	PTFE	1
	O-ring Cover	12	NP440147-TFE	PTFE	1
	O-ring Compression	13	NG440138-KLZ	Kalrez	1

Position 7 - NEMA C-Face and IEC B3/14 Metric Frame Magnetic Coupling Arrangement 56C NEMA frame components

	Description	Item	Part Number	Material	Qty
F	Casing	14	49610	Aluminum	1
	Spool 56C/143-5TC	19	49627	Aluminum	1
	Drive Magnet Assembly	15	49731	Stainless Steel	1
	Bolt	16	16722	Steel	4
	Bolt	20	W770424-STL	Steel	4
Motor Mount Kit #	E25XXUF				

143-145TC NEMA frame components

	Description	Item	Part Number	Material	Qty
O	Casing	14	49610	Aluminum	1
	Spool 56C/143-5TC	19	49627	Aluminum	1
	Drive Magnet Assembly	15	49732	Stainless Steel	1
	Bolt	16	16722	Steel	1
	Bolt	20	W770424-STL	Steel	4
	Motor Mount Kit #	E25XXUO			

80 IEC B34 frame components

	Description	Item	Part Number	Material	Qty
K	Casing	14	49610	Aluminum	1
	Spool	19	49727	Aluminum	1
	Drive Magnet Assembly	15	49733	Stainless Steel	1
	Bolt, Casing	16	16722	Steel	4
	Bolt, Motor	20	NP990415-STL	Steel	4
	Motor Mount Kit #	E25XXUK			

90 IEC B34 frame components

	Description	Item	Part Number	Material	Qty
L	Casing	14	49610	Aluminum	1
	Spool	19	49728	Aluminum	1
	Drive Magnet Assembly	15	49734	Stainless Steel	1
	Bolt, Casing	16	16722	Steel	4
	Bolt, Motor	20	NP990478-STL	Steel	4
	Motor Mount Kit #	E25XXUL			

Consult factory for Position 9 Options

KOPkit Suffix Selection Bill of Materials

	Description	Item	Qty
-LTE	Liner, Housing	7	1
	Gear Assembly, Drive	8	1
	Gear Assembly, Idler	9	1
	O-ring Cover	12	1

	Description	Item	Qty
-STD	Liner, Housing	7	1
	Gear Assembly, Drive	8	1
	Gear Assembly, Idler	9	1
	Bearing, Housing	10	1
	Pin, Bearing Lock		2
	Wear Plate		2
	Bearing		2
	O-ring Cover	12	1
	O-ring Compression	13	1

17. Parts Diagram and List, Eclipse 75 Non-Metallic

*SECOND ADAPTOR
USED WITH LARGER
NEMA FRAME SIZES

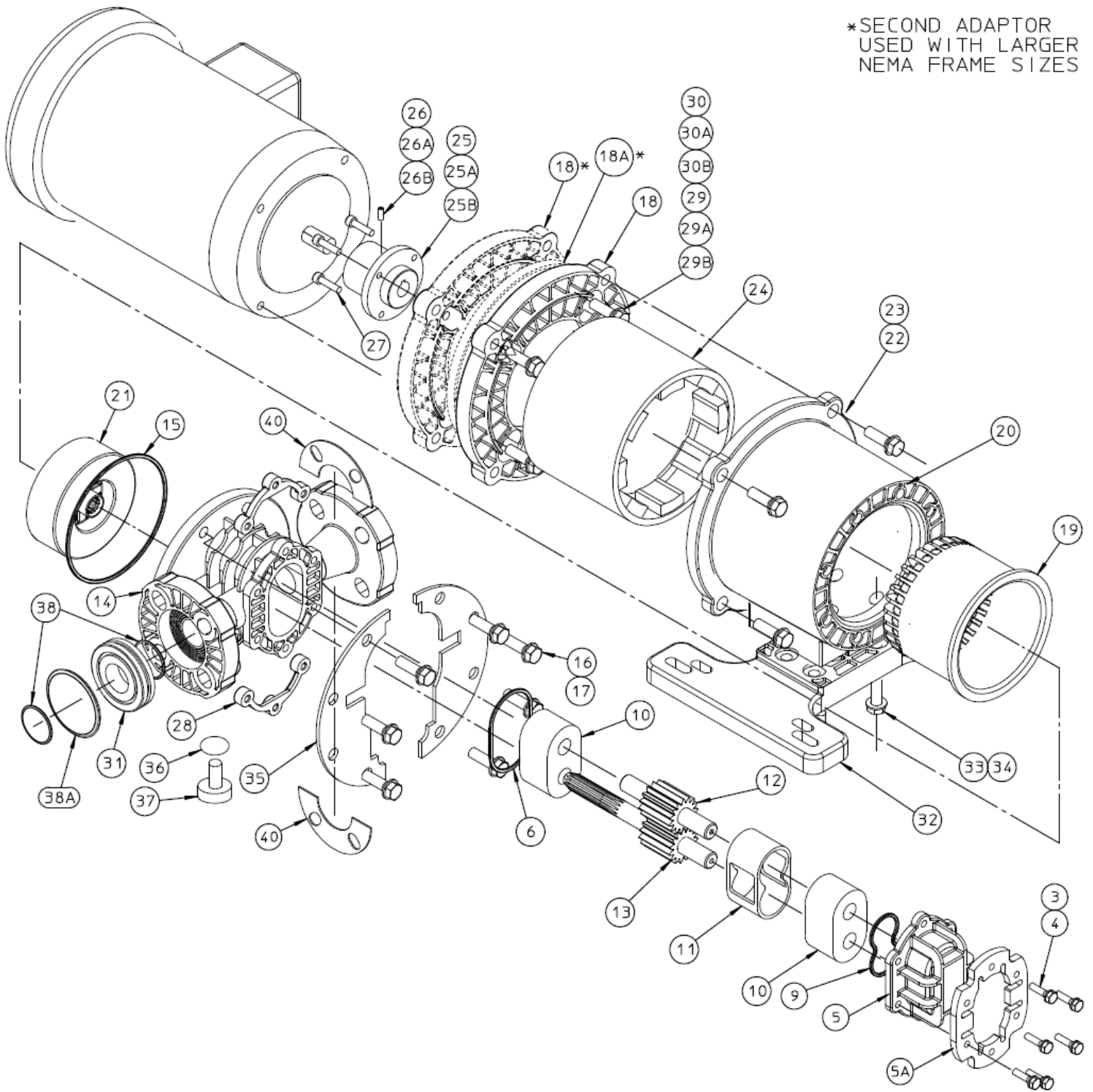

Eclipse Pump Series Size 75 Non-Metallic

Consolidated Bill of Material

			Position 4 Base Pump Material and Port Connection		
Position 1,2,3,4 - Base Pump Material/Ports (* Denotes recommended spares)			PVDF Flanged (N)		
E75	Description	Item	Part Number:	Material	Qty
Common Parts	Bolt	3	W770429-188	Stainless Steel	6
	Washer	4	NG990019-188	Stainless Steel	6
	Plate, Nut	28	NG990011-188	Stainless Steel	2
	Plate, Reinforcement	35	NG120008-188	Stainless Steel	2
	Plate, Cover Reinforcement	5A	NG120014-188	Stainless Steel	1
	Plate, Flange Reinforcement	40	NG120015-188	Stainless Steel	4
	Bolt	16	W770429-188	Stainless Steel	8
	Washer	17	NG990019-188	Stainless Steel	8
	Gasket, Flange	31	NG130002-VTN	Viton	2
	Name Plate	1	NG550004-304	Stainless Steel	1
	Drive Screw	2	W771000-188	Stainless Steel	2
	Can, Containment	19	NG210007-PVD	Carbon filled PVDF	1
	Driven Magnet Assembly	21	NG200033-TEF	Neo / ETFE	1
	Drive Magnet	24	NG200037-STL	Neo / Steel	1
	Adapter, Spool	20	NG110011-ALU	Aluminum	1
	Base	32	NG970001-PET	Polyester	1
	Bolt	33	W770425-188	Stainless Steel	4
	Washer	34	NG990019-188	Stainless Steel	4
Drain Plug	37	NG990014-FTE	ETFE	1	
N	Housing, Center Flanged	14	NG040024-PVD	Carbon filled PVDF	1
	Cover, Front	5	NG020004-PVD	Carbon filled PVDF	1

Position 5 - Bearing Materials

	Description	Item	Part Number:	Material	Qty
Common Parts	Liner, Housing *	11	NG220005-FTE	ETFE	1
	Gear Assembly, Drive *	13	NG010020-FTE	ETFE / ALA	1
	Gear Assembly, Idler *	12	NG010019-FTE	ETFE / ALA	1
B	Bearing *	10	NG080004-SIC	Silicon Carbide	2

Position 6 - O-ring Material Selection

	Description	Item	Part Number:	Material	Qty
V	O-ring Containment Can *	15	NG440163-VTA	Viton A	1
	O-ring Cover *	6	NG440155-VTA	Viton A	1
	O-ring Drain Plug *	36	NG440012-VTA	Viton A	1
	O-ring Compression *	9	NG440152-VTA	Viton A	1

Position 7 - NEMA C-Face and IEC B14/B34 Metric Frame Magnetic Coupling Arrangement

80 IEC B14/B34 frame components		Item	Part Number:	Material	Qty
K	Coupling Hub 80	25A	NG940005-STL	Steel	1
	Adaptor, Motor	26A	NG110024-ALU	Aluminum	1
	Set Screw	26A	NP991004-001	Steel	1
	Bolt	29A	NP999121-188	Stainless Steel	4
	Washer	30A	NP991017-188	Stainless Steel	4
	Bolt	22	W770427-188	Stainless Steel	4
	Washer	23	NG990019-188	Stainless Steel	4
	Screw	27	W770021-188	Stainless Steel	4
Motor Mount Kit #	E75XXXK				

90 IEC B14/B34 frame components		Item	Part Number:	Material	Qty
L	Coupling Hub 90	25A	NG940013-STL	Steel	1
	Adaptor, Motor	26A	NG110024-ALU	Aluminum	1
	Set Screw	26A	NP991004-018	Steel	1
	Bolt	29A	NP999004-188	Stainless Steel	4
	Washer	30A	NP991018-188	Stainless Steel	4
	Bolt	22	W770427-188	Stainless Steel	4
	Washer	23	NG990019-188	Stainless Steel	4
	Screw	27	W770021-188	Stainless Steel	4
Motor Mount Kit #	E75XXXL				

143TC - 182C NEMA frame components		Item	Part Number:	Material	Qty
O	Coupling Hub	25A	NG940003-STL	Steel	1
	Set Screw	26A	W771004-031	Steel	1
	Bolt	29A	W770425-188	Stainless Steel	4
	Washer	30A	NG990019-188	Stainless Steel	4
	Bolt	22	W770428-188	Stainless Steel	4
	Washer	23	NG990019-188	Stainless Steel	4
	Adapter, Motor	18	NG110008-PET	Polyester	1
	Screw	27	W770021-188	Stainless Steel	4
Motor Mount Kit #	E75XXXO				

182TC - 184TC NEMA frame components		Item	Part Number:	Material	Qty
R	Coupling Hub	25	NG940007-STL	Steel	1
	Set Screw	26	W771004-046	Steel	1
	Bolt	29	W770438-188	Stainless Steel	4
	Washer	30	W771035-188	Stainless Steel	4
	Bolt	22	W770428-188	Stainless Steel	4
	Washer	23	NG990019-188	Stainless Steel	4
	Adapter, Motor	18	NG110008-PET	Polyester	1
	Screw	27	W770021-188	Stainless Steel	4
Motor Mount Kit #	E75XXXR				

213TC - 215TC NEMA frame components		Item	Part Number:	Material	Qty
W	Coupling Hub	25B	NG940015-000	Steel	1
	Set Screw	26B	W771004-041	Steel	1
	Adapter, Motor	18	NG110008-PET	Polyester	2
	Mate, Motor Adaptor	18A	NG110023-STL	Steel	1
	Bolt (motor)	29	W770438-188	Stainless Steel	4
	Washer (motor)	30	W771035-188	Stainless Steel	4
	Bolt – spool	22	W770062-188	Stainless Steel	4
	Washer – spool	23	NG990019-188	Stainless Steel	4
	Screw	27	W770021-188	Stainless Steel	4
Motor Mount Kit #	E75XXXW				

254TC - 256TC NEMA frame components		Item	Part Number:	Material	Qty
Z	Coupling Hub	25B	NG940012-STL	Steel	1
	Set Screw	26B	W771004-041	Steel	1
	Adapter, Motor	18	NG110008-PET	Polyester	2
	Mate, Motor Adaptor	18A	NG110023-STL	Steel	1
	Bolt	29B	W770438-188	Stainless Steel	4
	Washer	30B	W771035-188	Stainless Steel	4
	Bolt – spool	22	W770062-188	Stainless Steel	4
	Washer – spool	23	NG990019-188	Stainless Steel	4
	Screw	27	W770021-188	Stainless Steel	4
Motor Mount Kit #	E75XXXZ				

100/112 IEC B14/B34 frame components		Item	Part Number:	Material	Qty
P	Coupling Hub	25B	NG940006-STL	Steel	1
	Set Screw	26B	NP991004-018	Steel	1
	Bolt	29B	W770534-188	Stainless Steel	4
	Washer	30B	NP991018-188	Stainless Steel	4
	Bolt	22	W770428-188	Stainless Steel	4
	Washer	23	NG990019-188	Stainless Steel	4
	Adapter, Motor	18	NG110008-PET	Polyester	1
	Screw	27	W770021-188	Stainless Steel	4
Motor Mount Kit #	E75XXXP				

132 IEC B14/B34 frame components		Item	Part Number:	Material	Qty
V	Coupling Hub	25B	NG940014-STL	Steel	1
	Set Screw	26B	NP992570-188	Steel	1
	Bolt	29B	W770547-STL	Stainless Steel	4
	Washer	30B	NP991018-188	Stainless Steel	4
	Bolt – spool	22	W770428-188	Stainless Steel	4
	Adaptor, 132 Motor	18	NG110022-ALU	Aluminum	1
	Washer – spool	23	NG990019-188	Stainless Steel	4
	Screw	27	W770021-188	Stainless Steel	4
Motor Mount Kit #	E75XXXV				

Consult factory for Position 9 Options

KOPkit Suffix Selection Bill of Materials

	Description	Item	Qty
-LTE	Liner, Housing	11	1
	Gear Assembly, Drive	13	1
	Gear Assembly, Liner	12	1
	O-ring Cover	6	1

	Description	Item	Qty
-STD	Bearing	10	2
	Liner, Housing	11	1
	Gear Assembly, Drive	13	1
	Gear Assembly, Liner	12	1
	O-ring Cover	6	1
	O-ring Compression	9	2

	Description	Item	Qty
-PRO	Bearing	10	2
	Liner, Housing	11	1
	Gear Assembly, Drive	13	1
	Gear Assembly, Liner	12	1
	O-ring Cover	6	1
	O-ring Compression	9	2
	Bolt	3	6
	Washer	4	6
	Plate, Nut	28	2
	Plate, Cover Reinforcement	5A	1

18. Parts Diagram and List, Eclipse 125 Non-Metallic

*SECOND ADAPTOR
USED WITH LARGER
NEMA FRAME SIZES

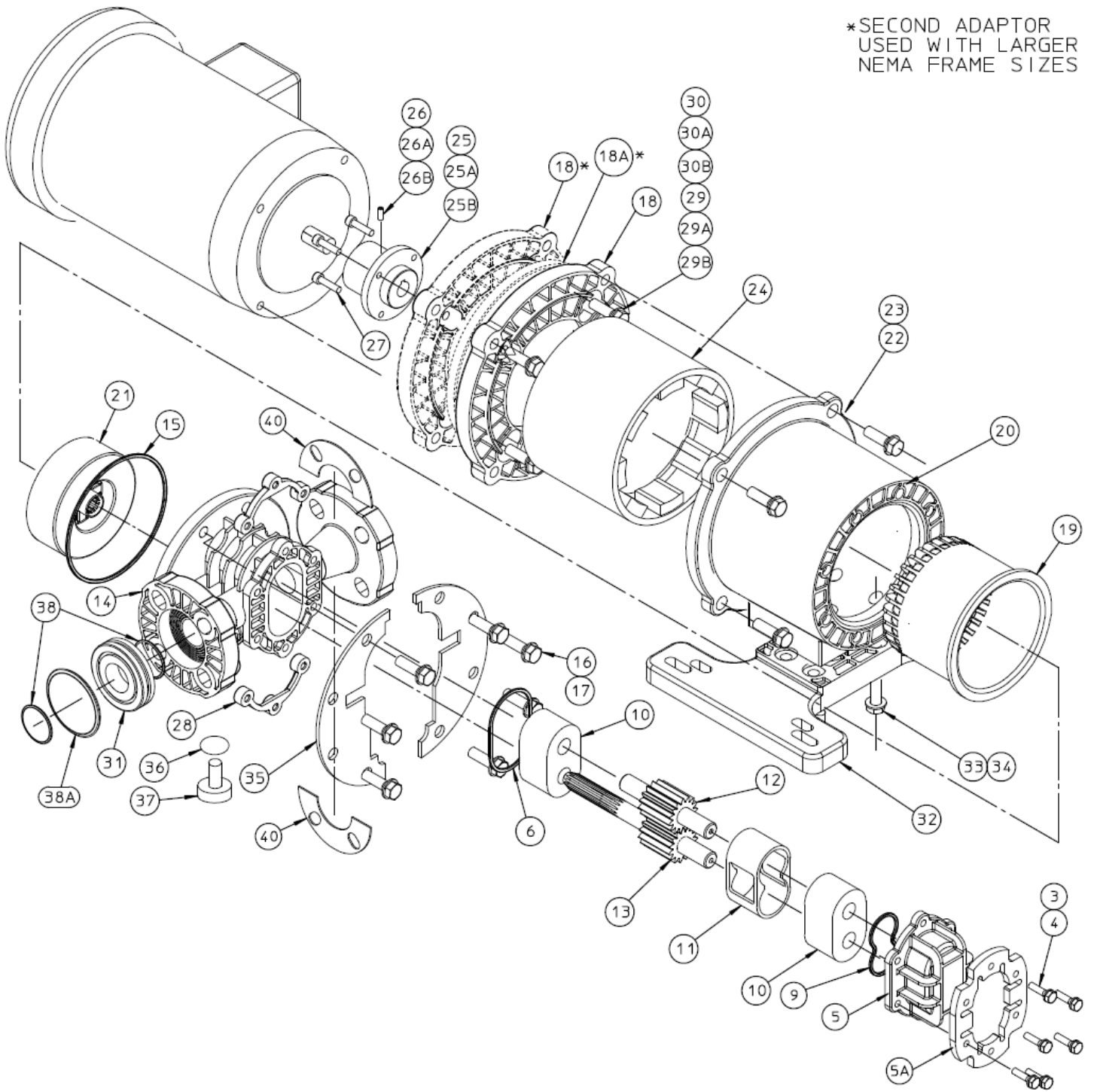

Eclipse Pump Series Size 125 Non-Metallic

Consolidated Bill of Material

			Position 5 Base Pump Material and Port Connection		
Position 1,2,3,4,5 - Base Pump Material/Ports (* Denotes recommended spares)			PVDF Flanged (N)		
E125	Description	Item	Part Number:	Material	Qty
Common Parts	Bolt	3	W770429-188	Stainless Steel	6
	Washer	4	NG990019-188	Stainless Steel	6
	Plate, Nut	28	NG990011-188	Stainless Steel	2
	Plate, Reinforcement	35	NG120008-000	Stainless Steel	2
	Plate, Cover Reinforcement	5A	NG120014-188	Stainless Steel	1
	Plate, Flange Reinforcement	40	NG120015-188	Stainless Steel	4
	Bolt	16	W770429-188	Stainless Steel	8
	Washer	17	NG990019-188	Stainless Steel	8
	Gasket, Flange	31	NG130002-VTN	Viton A	2
	Name Plate	1	NG550004-304	Stainless Steel	1
	Drive Screw	2	W771000-188	Stainless Steel	2
	Can Containment	19	NG210007-PVD	Carbon filled PVDF	1
	Driven Magnet Assembly	21	NG200033-TEF	Neo / ETFE	1
	Drive Magnet	24	NG200037-STL	Neo / Steel	1
	Adapter, Spool	20	NG110011-ALU	Aluminum	1
	Bolt	33	W770425-188	Stainless Steel	4
	Washer	34	NG990019-188	Stainless Steel	4
	Base	32	NG970001-PET	Polyester	1
	Drain Plug	37	NG990014-FTE	ETFE	1
N	Housing, Center Flanged	14	NG040024-PVD	Carbon filled PVDF	1
	Cover, Front	5	NG020004-PVD	Carbon filled PVDF	1

Position 6 - Bearing Materials

	Description	Item	Part Number:	Material	Qty
Common Parts	Liner, Housing *	11	NG220007-FTE	ETFE	1
	Gear Assembly, Drive *	13	NG010025-FTE	ETFE / ALA	1
	Gear Assembly, Idler *	12	NG010024-FTE	ETFE / ALA	1
B	Bearing *	10	NG080007-SIC	Silicon Carbide	2

Position 7 - O-ring Material Selection

	Description	Item	Part Number:	Material	Qty
V	O-ring Containment Can *	15	NG440163-VTA	Viton A	1
	O-ring Cover *	6	NG440155-VTA	Viton A	1
	O-ring Drain Plug *	36	NG440012-VTA	Viton A	1
	O-ring Compression *	9	NG440152-VTA	Viton A	1

Position 8 - NEMA C-Face and IEC B14 Metric Frame Magnetic Coupling Arrangement

143TC - 182C NEMA frame components		Item	Part Number:	Material	Qty
O	Coupling Hub	25A	NG940003-STL	Steel	1
	Set Screw	26A	W771004-031	Steel	1
	Bolt	29A	W770425-188	Stainless Steel	4
	Washer	30A	NG990019-188	Stainless Steel	4
	Bolt	22	W770428-188	Stainless Steel	4
	Washer	23	NG990019-188	Stainless Steel	4
	Adapter, Motor	18	NG110008-PET	Polyester	1
	Screw	27	W770021-188	Stainless Steel	4
Motor Mount Kit #	E125XXXO				

182TC - 184TC NEMA frame components		Item	Part Number:	Material	Qty
R	Coupling Hub	25	NG940007-STL	Steel	1
	Set Screw	26	W771004-046	Steel	1
	Bolt (motor)	29	W770438-188	Stainless Steel	4
	Washer (motor)	30	W771035-188	Stainless Steel	4
	Bolt (spool)	22	W770428-188	Stainless Steel	4
	Adapter, Motor	18	NG110008-PET	Polyester	1
	Washer (base)	23	NG990019-188	Stainless Steel	4
	Screw	27	W770021-188	Stainless Steel	4
Motor Mount Kit #	E125XXXR				

213TC - 215TC NEMA frame components		Item	Part Number:	Material	Qty
W	Coupling Hub	25B	NG940015-000	Steel	1
	Set Screw	26B	W771004-041	Steel	1
	Adapter, Motor	18	NG110008-PET	Polyester	2
	Mate, Motor Adaptor	18A	NG110023-STL	Steel	1
	Bolt (motor)	29	W770438-188	Stainless Steel	4
	Washer (motor)	30	W771035-188	Stainless Steel	4
	Bolt – spool	22	W770062-188	Stainless Steel	4
	Washer - spool	23	NG990019-188	Stainless Steel	4
	Screw	27	W770021-188	Stainless Steel	4
Motor Mount Kit #	E125XXXW				

254TC - 256TC NEMA frame components		Item	Part Number:	Material	Qty
Z	Coupling Hub	25B	NG940012-STL	Steel	1
	Set Screw	26B	W771004-041	Steel	1
	Adapter, Motor	18	NG110008-PET	Polyester	2
	Mate, Motor Adaptor	18A	NG110023-STL	Steel	1
	Bolt	29B	W770438-188	Stainless Steel	4
	Washer	30B	W771035-188	Stainless Steel	4
	Bolt – spool	22	W770062-188	Stainless Steel	4
	Washer - spool	23	NG990019-188	Stainless Steel	4
	Screw	27	W770021-188	Stainless Steel	4
Motor Mount Kit #	E125XXXZ				

100/112 IEC B14 frame components		Item	Part Number:	Material	Qty
P	Coupling Hub	25B	NG940006-STL	Steel	1
	Set Screw	26B	NP991004-018	Steel	1
	Bolt – motor	29B	W770534-188	Stainless Steel	4
	Washer - motor	30B	NP991018-188	Stainless Steel	4
	Bolt – spool	22	W770438-188	Stainless Steel	4
	Adapter, Motor	18	NG110008-PET	Polyester	1
	Washer - base	23	NG990019-188	Stainless Steel	4
	Screw	27	W770021-188	Stainless Steel	4
Motor Mount Kit #	E125XXXP				

132 IEC B14 frame components		Item	Part Number:	Material	Qty
V	Coupling Hub	25B	NG940014-STL	Steel	1
	Set Screw	26B	NP992570-188	Steel	1
	Bolt	29B	W770547-STL	Stainless Steel	4
	Washer	30B	NP991018-188	Stainless Steel	4
	Bolt – spool	22	W770428-188	Stainless Steel	4
	Adaptor, 132 Motor	18	NG110022-ALU	Aluminum	1
	Washer - spool	23	NG990019-188	Stainless Steel	4
	Screw	27	W770021-188	Stainless Steel	4
Motor Mount Kit #	E125XXXV				

Consult factory for Position 9 Options

KOPkit Suffix Selection Bill of Materials

	Description	Item	Qty
-LTE	Liner, Housing	11	1
	Gear Assembly, Drive	13	1
	Gear Assembly, Liner	12	1
	O-ring Cover	6	1

	Description	Item	Qty
-STD	Bearing	10	2
	Liner, Housing	11	1
	Gear Assembly, Drive	13	1
	Gear Assembly, Liner	12	1
	O-ring Cover	6	1
	O-ring Compression	9	2

	Description	Item	Qty
-PRO	Bearing	10	2
	Liner, Housing	11	1
	Gear Assembly, Drive	13	1
	Gear Assembly, Liner	12	1
	O-ring Cover	6	1
	O-ring Compression	9	2
	Bolt	3	6
	Washer	4	6
	Plate, Nut	28	2
	Plate, Cover Reinforcement	5A	1

19. Dimensional Drawings

19.1 Eclipse O2 Non-Metallic

MOTOR FRAME	U DIA. SHAFT	W KEY WIDTH	H KEY HEIGHT
56C	.626 15.9	.188 4.7	.71 18.0
140TC	.876 22.2	.188 4.7	.96 24.5
180C	.434 11.0	.159 4.0	.51 12.9
71	.553 14.0	.196 5.0	.64 16.0
80	.750 19.1	.297 6.0	.865 22.0

- NOTES:
1. SUCTION AND DISCHARGE PORTS DEPENDENT UPON PUMP SHAFT ROTATION.
 2. STANDARD MOTOR ADAPTOR FITS NEMA 56C, 143TC, 182C AND 184C FRAME MOTORS.
 3. METRIC MOTOR ADAPTOR OPTION FITS 63, 71 AND 80 FRAME MOTORS.
 4. MUST USE FOOT MOUNTED, C-FACE MOTOR OF SPECIFIED FRAME SIZES.

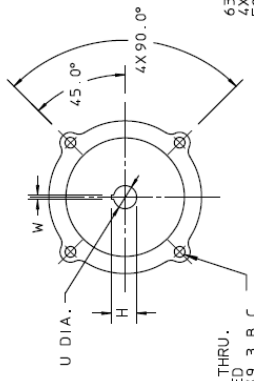
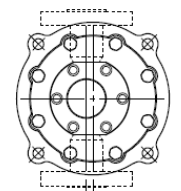
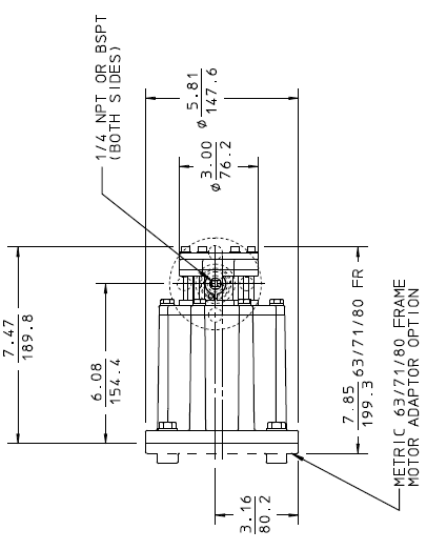
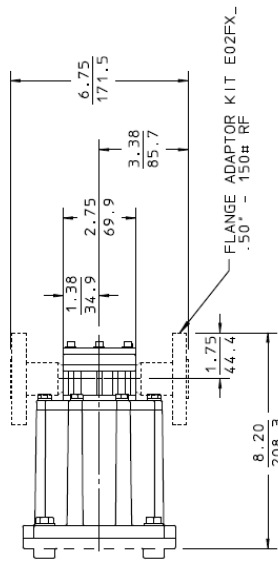

63
4X ϕ .41/10.4 THRU.
EQUALLY SPACED
ON A ϕ 5.88/149.3 B.C.

**56C-184C FR NEMA
MOTOR MOUNTING**

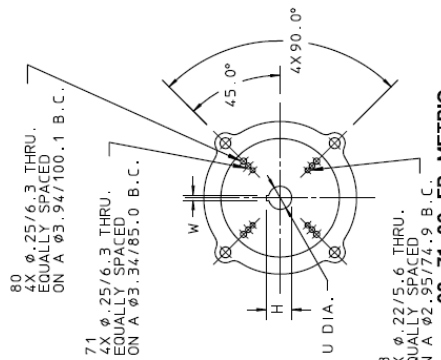

80
4X ϕ .25/6.3 THRU.
EQUALLY SPACED
ON A ϕ 3.94/100.1 B.C.

71
4X ϕ .25/6.3 THRU.
EQUALLY SPACED
ON A ϕ 3.34/85.0 B.C.

63
4X ϕ .22/5.6 THRU.
EQUALLY SPACED
ON A ϕ 2.95/74.9 B.C.

**63-71-80 FR METRIC
MOTOR MOUNTING**

ALL DIMENSIONS ARE IN INCHES/MM		SCALE: 1-4	Item = No.	E02 / EHO2
Customer			Model	SEE CHART
Project No.			Motor Pwr/Fr	
Part No./SO No.			Unit Weight	kg
SECTION/PAGE ECLIPSE 2 / 101		PULSAFEEDER A Unit of DEK Corporation		
EFFECTIVE	11/05/14	Name	Date	SD-2875-000
SUPERSEDES	04/16/13	KLM	11/05/14	
Revision Description		JRY	05/12/04	
		JRY	05/12/04	

19.2 Eclipse 02 Metallic

MOTOR FRAME	U DIA. SHAFT
56C	.626 / 15.9

NOTES:

1. SUCTION AND DISCHARGE PORTS DEPENDENT UPON PUMP SHAFT ROTATION.
2. STANDARD MOTOR ADAPTOR FITS NEMA 56C FRAME MOTORS.
3. MUST USE FOOT MOUNTED C-FACE MOTOR OF SPECIFIED FRAME SIZE. SEE CHART.

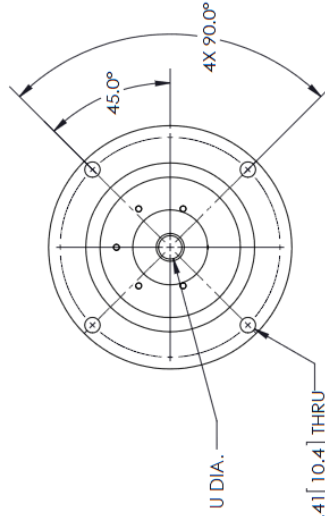
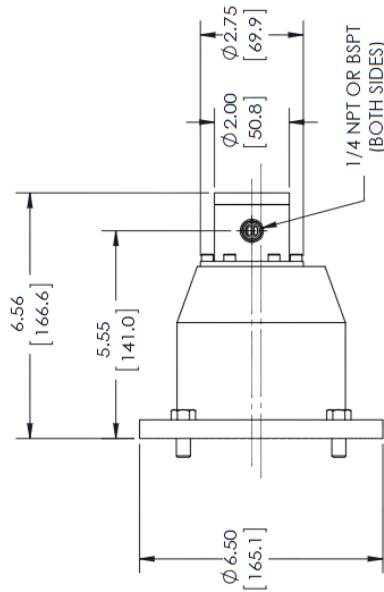
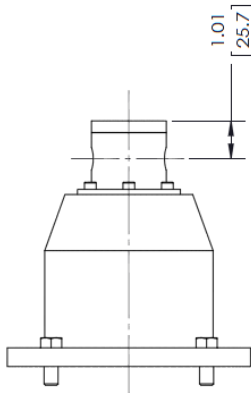

4X ϕ .41 [10.4] THRU EQUALLY SPACED ON A ϕ 5.88 [149.2] B.C.
56C FR NEMA MOTOR MOUNTING

ALL DIMENSIONS ARE IN INCHES/MM		SCALE: 1:3	Item - No.	E02-3101-SS
Customer			Model	SEE CHART
Project No.			Motor Pwr/Fr	lb
Po No./SO No.			Unit Weight	kg
Rev	Revision Description	Name	Date	Drawing No.
		EAK	01/27/15	
		KLM	01/29/15	
PULSAFEEDER A UNIT OF IDEX CORPORATION				SD-3108

19.3 Eclipse 05 Non-Metallic

NOTES:

- SUCTION AND DISCHARGE PORTS DEPENDENT UPON PUMP SHAFT ROTATION
- STANDARD MOTOR ADAPTOR FITS NEMA 56C, 143TC, 182C AND 184C[®] FRAME MOTORS
- METRIC MOTOR ADAPTOR OPTION FITS 63, 71 AND 80 FRAME MOTORS
- MUST USE FOOT MOUNTED, C-FACE MOTOR OF SPECIFIED FRAME SIZES

E05 WITH FLANGE ADAPTOR KIT: E05FX-

ANSI: .50" -150# RF
DIN: 10, 15

2X Ø 3.75
95.25

12
3.2

8.75

222.3

4.38

111.1

111.1

3.50

88.9

1/8 NPT
OPTIONAL
FLUSH
PORT

PORT
CENTERLINE

MOTOR
CENTERLINE

47

11.9

3/8 NPT OR BSPT
(BOTH SIDES)

3.81

5.81

96.8

147.6

1/8 NPT DRAIN

8.29

210.7

63/71/80 FR

210.7

63/71/80 FRAME
MOTOR ADAPTOR OPTION

45.0°

4X 90.0°

U DIA.

H

W

45.0°

4X 90.0°

U DIA.

H

W

80 Ø .25/6.3 THRU,
EQUALLY SPACED
ON A Ø 3 94/100.1 B.C.

71 Ø .25/6.3 THRU,
EQUALLY SPACED ON,
Ø 3.34/85.0 B.C.

63 Ø .22/5.6 THRU,
EQUALLY SPACED
ON A Ø 2.95/74.9 B.C.

**56C-184C FR NEMA
MOTOR MOUNTING**

**63-71-80 FR METRIC
MOTOR MOUNTING**

MOTOR FRAME	U DIA. SHAFT	W KEY WIDTH	H KEY HEIGHT
56C	.626 15.9	.188 4.7	.71 18.0
140TC	.876 22.2	.188 4.7	.96 24.5
180C	.434 11.0	.159 4.0	.51 12.9
71	.553 14.0	.196 5.0	.64 16.0
80	.750 19.1	.237 6.0	.865 22.0

Customer		Project No.		SECTION/PAGE	
ECLIPSE 3 / 101		ECLIPSE 3 / 101		ECLIPSE 3 / 101	
Po No./SO No.		AFL 06/11/13		EFFECTIVE	
Model		Revision Description		12/21/07	
Motor Pwr/Fr		Name		SUPERSEDES	
Unit Weight		Date		6/23/05	
lb		Name		JRY	
kg		Date		05/12/05	
Eclipse		Checked		JRY	
A Unit of BEC Corporation		Date		05/12/05	
Drawing No.		Name		JRY	
SD-2978-000		Date		05/12/05	

ALL DIMENSIONS ARE IN INCHES/MM

SCALE: 1:4

Item - No.

ECLIPSE E05/EH05

SEE CHART

19.4 Eclipse 05 Metallic

MOTOR FRAME	U DIA. SHAFT	W KEY WIDTH	H KEY HEIGHT
56C	.626 / 15.9	.188 / 4.7	.71 / 18.0
140TC	.876 / 22.2	.188 / 4.7	.96 / 24.5

NOTES:

1. SUCTION AND DISCHARGE PORTS DEPENDENT UPON PUMP SHAFT ROTATION.
2. STANDARD MOTOR ADAPTOR FITS NEMA 56C, 143TC, AND 145TC FRAME MOTORS.
3. MUST USE FOOT MOUNTED C-FACE MOTOR OF SPECIFIED FRAME SIZE. SEE CHART.

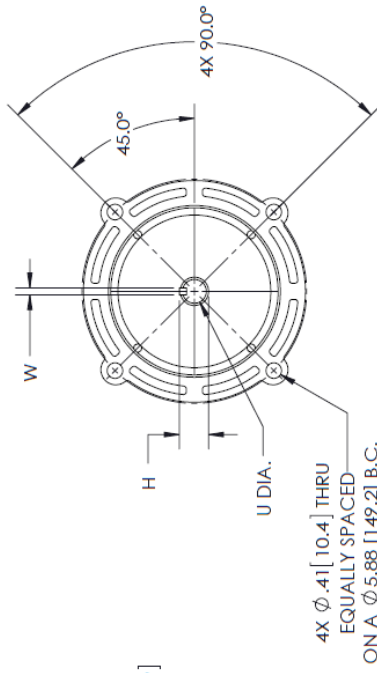
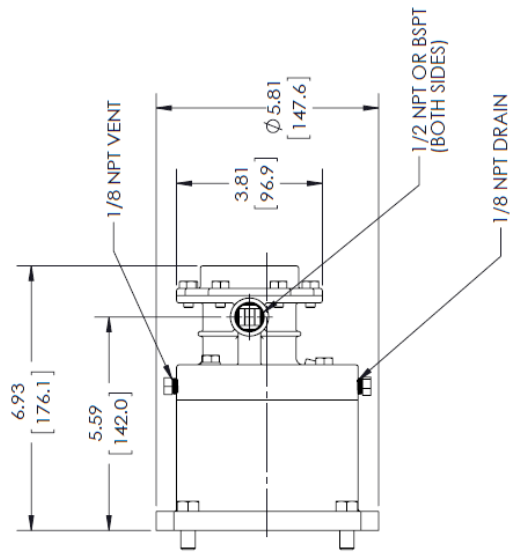
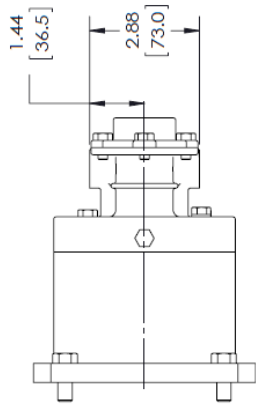

56 - 140TC FR NEMA MOTOR MOUNTING

ALL DIMENSIONS ARE IN INCHES/mm		SCALE: 1:3	Item No.
Customer			E05, 316L SS
Project No.			NEMA 56C-140TC
Po No./SO No.			Unit Weight
			lb
			kg
ECN D379: CHG FLANGE DIMENSIONS		EAK	03/25/15
Revision Description		Name	Date
Rev		EAK	01/19/15
		KLM	01/19/15
		Checked	Drawing No.
			SD-3107



19.5 Eclipse 12 Non-Metallic

MOTOR FRAME	U DIA SHAFT	W KEY WIDTH	H KEY HEIGHT
56C	626 15.9	188 4.7	71 18.0
140TC	876	188	96
180C	22.2	4.7	24.5
63	434 11.0	.159 4.0	.51 12.9
71	551 14.0	.196 5.0	.64 16.0
80	750 19.1	.237 6.0	.865 22.0

- NOTES:
 1. SUCTION AND DISCHARGE PORTS DEPENDENT UPON PUMP SHAFT ROTATION
 2. STANDARD MOTOR ADAPTOR FITS NEMA 56C, 143TC, 182C AND 184C FRAME MOTORS
 3. METRIC MOTOR ADAPTOR OPTION FITS 63, 71 AND 80 FRAME MOTORS.
 4. MUST USE FOOT MOUNTED C-FACE MOTOR OF SPECIFIED FRAME SIZES

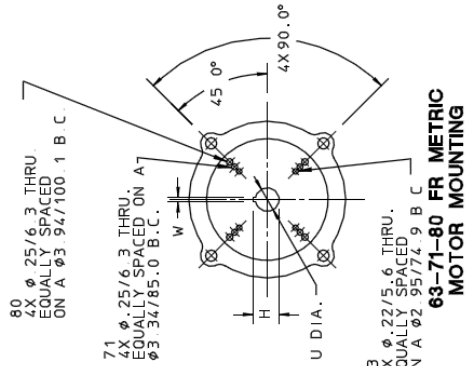
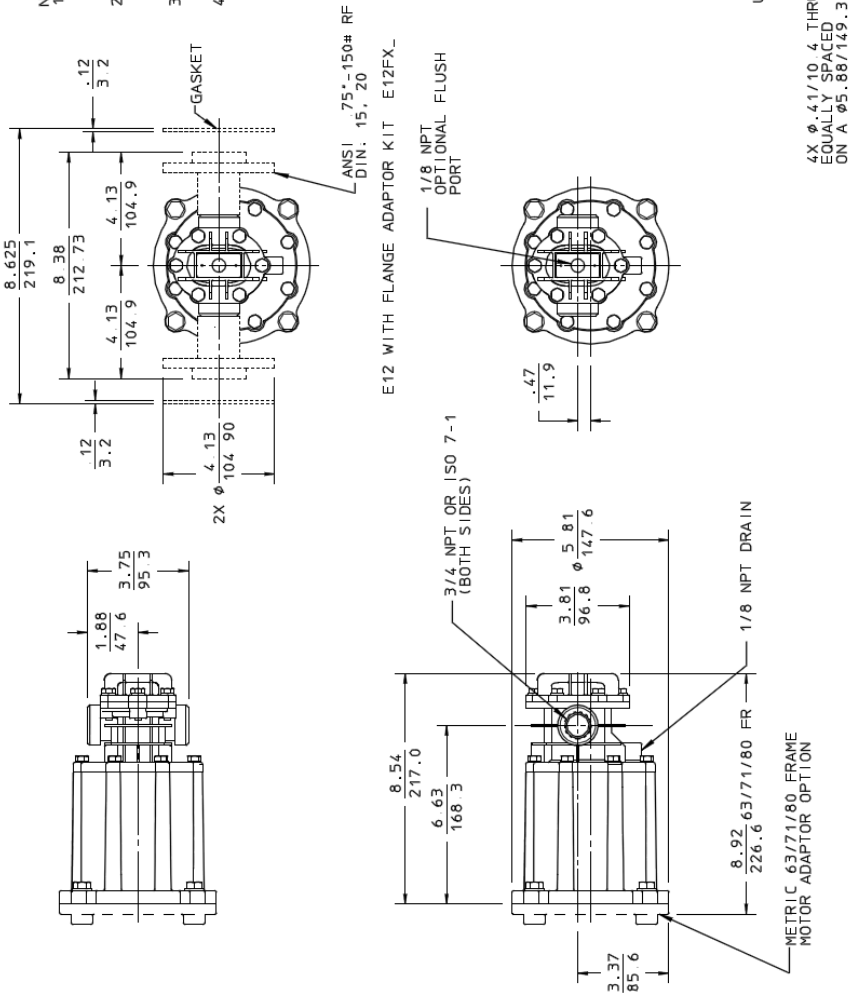

56C-184C FR NEMA MOTOR MOUNTING

63-71-80 FR METRIC MOTOR MOUNTING

ALL DIMENSIONS ARE IN INCHES/mm		RHA	X	SCALE: X X	Item = No.
Customer	Project No.		Po No./SO No.	Model	E12
Motor		Pwr/FF	Unit Weight	Motor Pwr/FF	SEE CHART
Name		Date	Name	Date	kg
D 8 625 WAS 8 5.8 38 WAS 8 25		11/05/14	KLM	04/06/06	b
Revision Description		Date	Checked	PTP	04/06/06
Rev		Date	Checked	PTP	04/06/06

SECTION/PAGE	ECLIPSE 10/ 101
EFFECTIVE	11/05/14
SUPERSEDES	04/16/13

Customer	Project No.		Po No./SO No.	Model	E12
Motor		Pwr/FF	Unit Weight	Motor Pwr/FF	SEE CHART
Name		Date	Name	Date	kg
D 8 625 WAS 8 5.8 38 WAS 8 25		11/05/14	KLM	04/06/06	b
Revision Description		Date	Checked	PTP	04/06/06
Rev		Date	Checked	PTP	04/06/06

Pulsafeeder		A Unit of BEC Corporation	
Drawing No.		SD-2990-000	

19.6 Eclipse 12 Metallic

MOTOR FRAME	U DIA. SHAFT	W KEY WIDTH	H KEY HEIGHT
56C	.626 / 15.9	.188 / 4.7	.71 / 18.0
143-5TC	.876 / 22.2	.188 / 4.7	.96 / 24.5
182-4C			

NOTES:

1. SUCTION AND DISCHARGE PORTS DEPENDENT UPON PUMP SHAFT ROTATION.
2. STANDARD MOTOR ADAPTOR FITS NEMA 56C, 143-5TC, AND 182-4C FRAME MOTORS.
3. MUST USE FOOT MOUNTED C-FACE MOTOR OF SPECIFIED FRAME SIZE. SEE CHART.

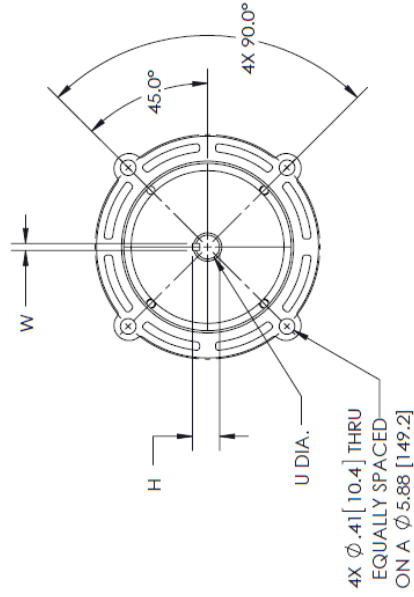
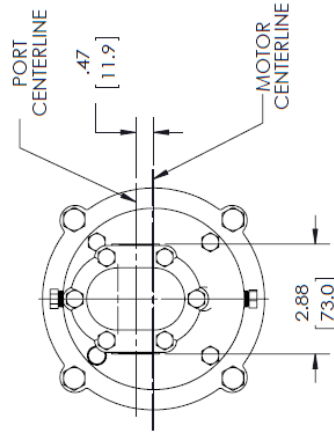
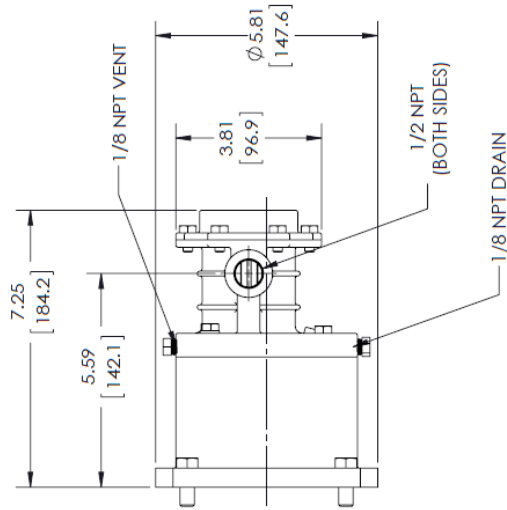
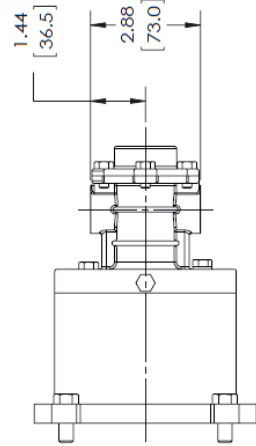

56C, 143-5TC, 182-4C FR NEMA MOTOR MOUNTING

ALL DIMENSIONS ARE IN INCHES/MM		SCALE: 1:3	Item No.
Customer		Model	E12, 316L SS
Project No.		Motor Pwr/Fr	SEE CHART
Po No./SO No.		Unit Weight	lb kg
EKN D379: CHG FLANGE DIMENSIONS		Name	
Rev	Revision Description	Date	Date
A		EAK	03/25/15
		KLM	01/27/15
		Checked	01/27/15
		Drawn	
		Drawing No.	3109



19.7 Eclipse 25 Non-Metallic

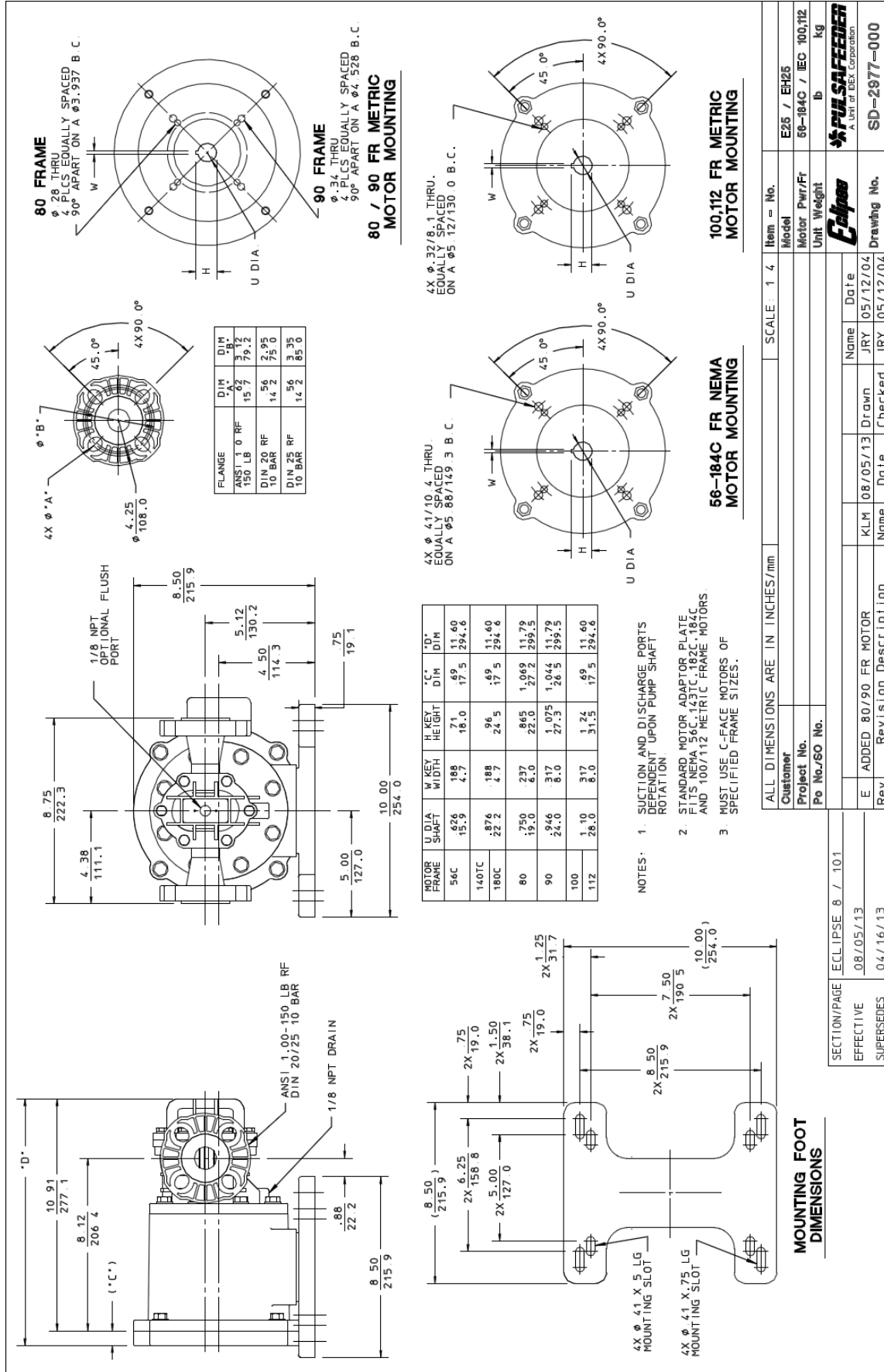

80 FRAME
 ϕ 28 THRU
 4 PLCS EQUALLY SPACED
 90° APART ON A ϕ 3.957 B.C.

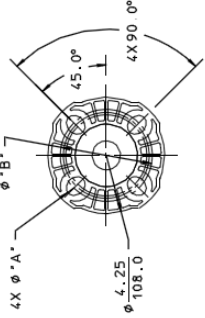

FLANGE	DIM	DIM
ANSI 10 RF	A	B
150 LB	15.7	79.2
DIN 20 RF	15.6	75.95
DIN 25 RF	14.2	75.0
10 BAR	14.2	75.0

90 FRAME
 ϕ 34 THRU
 4 PLCS EQUALLY SPACED
 90° APART ON A ϕ 4.528 B.C.

80 / 90 FR METRIC MOTOR MOUNTING

$4 \times \phi$ 41/10.4 THRU
 EQUALLY SPACED
 ON A ϕ 5.66/149.3 B.C.

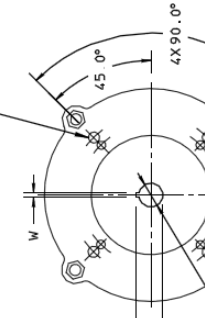

100,112 FR METRIC MOTOR MOUNTING

$4 \times \phi$ 41/10.4 THRU
 EQUALLY SPACED
 ON A ϕ 5.66/149.3 B.C.

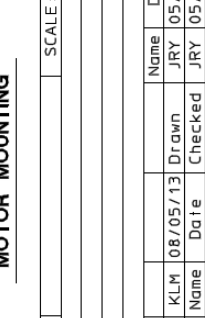

56-184C FR NEMA MOTOR MOUNTING

$4 \times \phi$ 41/10.4 THRU
 EQUALLY SPACED
 ON A ϕ 5.66/149.3 B.C.



MOTOR FRAME	U.D.I.A.	W KEY WIDTH	H KEY HEIGHT	C. DIM	I.D. DIM
56C	.626 15.9	.188 4.7	.71 18.0	.69 17.5	11.40 294.6
1400C	.876 22.2	.188 4.7	.96 24.5	.69 17.5	11.40 294.6
1800C	.750 19.0	.237 6.0	.865 22.0	1.049 27.2	11.79 299.5
80	.946 24.1	.317 8.0	1.075 27.3	1.045 26.5	13.79 350.5
90	1.10 28.0	.317 8.0	1.24 31.5	.69 17.5	11.40 294.6
100	1.10 28.0	.317 8.0	1.24 31.5	.69 17.5	11.40 294.6
112	1.10 28.0	.317 8.0	1.24 31.5	.69 17.5	11.40 294.6

- NOTES:
- SUCTION AND DISCHARGE PORTS DEPENDENT UPON PUMP SHAFT ROTATION.
 - STANDARD MOTOR ADAPTOR PLATE FITS NEMA 56C, 143TC, 182C, 182C AND 100/112 METRIC FRAME MOTORS.
 - MUST USE C-FACE MOTORS OF SPECIFIED FRAME SIZES.

Customer	Item = No.	SCALE	1	4
Project No.	Model	E26 / EH26		
Po No./SO No.	Motor Pwr/Fr	56-184C / IEC 100,112		
	Unit Weight	lb		
		kg		
SECTION/PAGE		ECLIPSE 8 / 10.1		
EFFECTIVE		08/05/13		
SUPERSEDES		04/16/13		
Rev	Revision Description	Name	Date	Checked
E	ADDED 80/90 FR MOTOR	KLM	08/05/13	JRY
				JRY

Item = No.	SCALE	1	4
Model	E26 / EH26		
Motor Pwr/Fr	56-184C / IEC 100,112		
Unit Weight	lb		
	kg		
SECTION/PAGE		ECLIPSE 8 / 10.1	
EFFECTIVE		08/05/13	
SUPERSEDES		04/16/13	
Rev	Revision Description	Name	Date
E	ADDED 80/90 FR MOTOR	KLM	08/05/13

MOUNTING FOOT DIMENSIONS

19.8 Eclipse 25 Metallic

MOTOR FRAME	U DIA. SHAFT	W KEY WIDTH	H KEY HEIGHT
56C	.626 / 15.9	.188 / 4.7	.71 / 18.0
143-5TC	.876 / 22.2	.188 / 4.7	.96 / 24.5
182-4C			

NOTES:

1. SUCTION AND DISCHARGE PORTS DEPENDENT UPON PUMP SHAFT ROTATION.
2. STANDARD MOTOR ADAPTOR FITS NEMA 56C, 143-5TC, AND 182-4C FRAME MOTORS.
3. MUST USE FOOT MOUNTED C-FACE MOTOR OF SPECIFIED FRAME SIZE. SEE CHART.

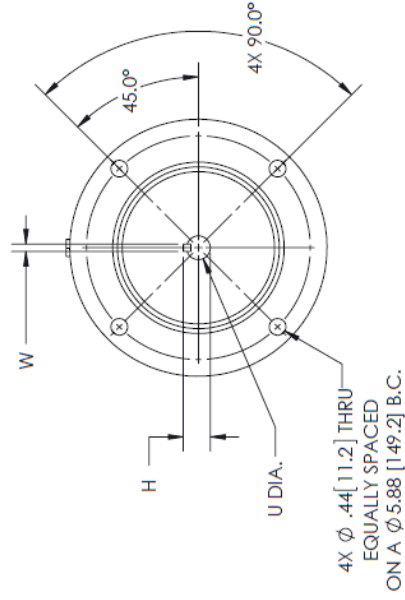
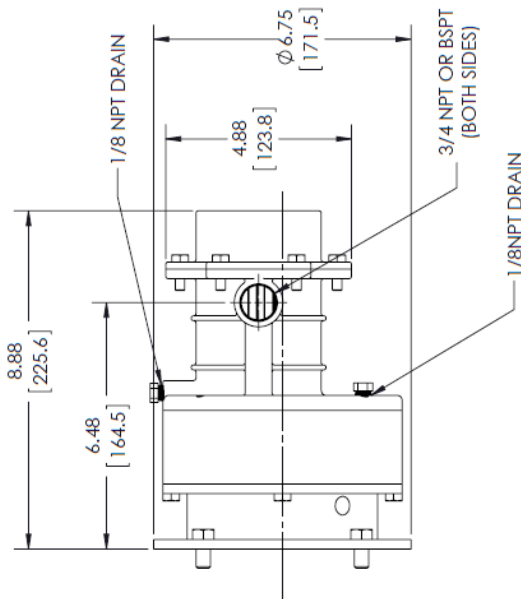
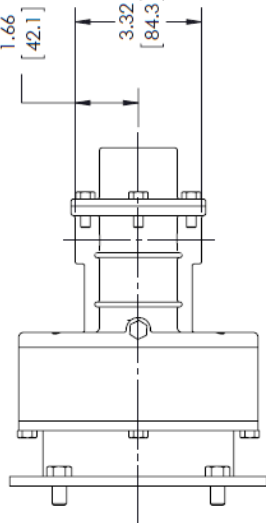

56C, 143-5TC, 182-4C FR NEMA MOTOR MOUNTING

ALL DIMENSIONS ARE IN INCHES/mm		SCALE: 1:3	Item - No.
Customer			Model
Project No.			Motor Pwr/Fr
Po No./SO No.			Unit Weight
		Name	Date
A	ECN D379: CHG CAST DIMENSIONS	EAK	03/25/15
Rev	Revision Description	Name	Date
		Checked	01/27/15
		KLM	01/27/15
Drawing No.			SD-3110



19.9 Eclipse 75/125 Non-Metallic

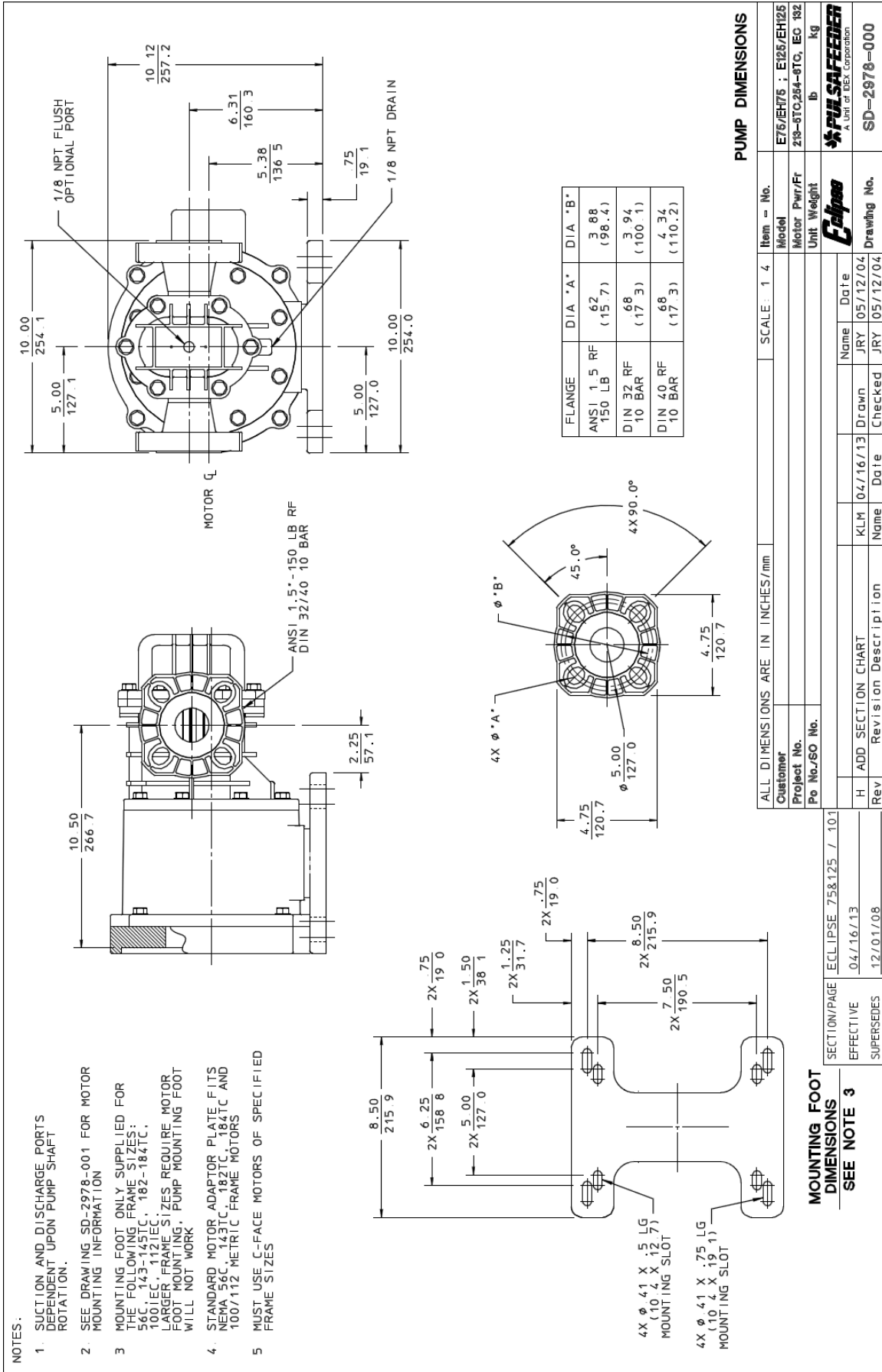

20. Performance Curves

20.1 E02

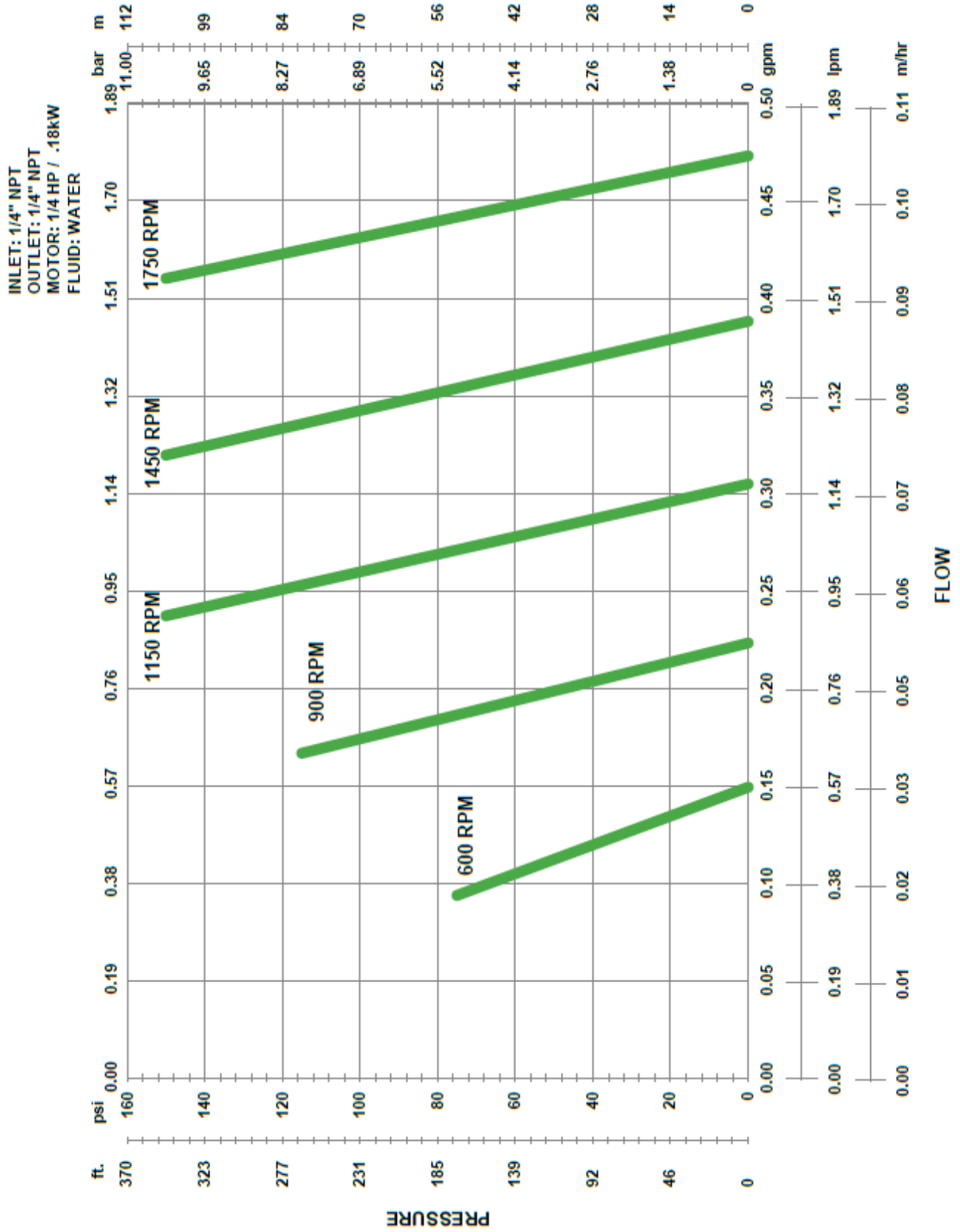

20.2 E05

INLET: 3/8" NPT
 OUTLET: 3/8" NPT
 MOTOR: 1/2 HP / .55kW
 FLUID: WATER

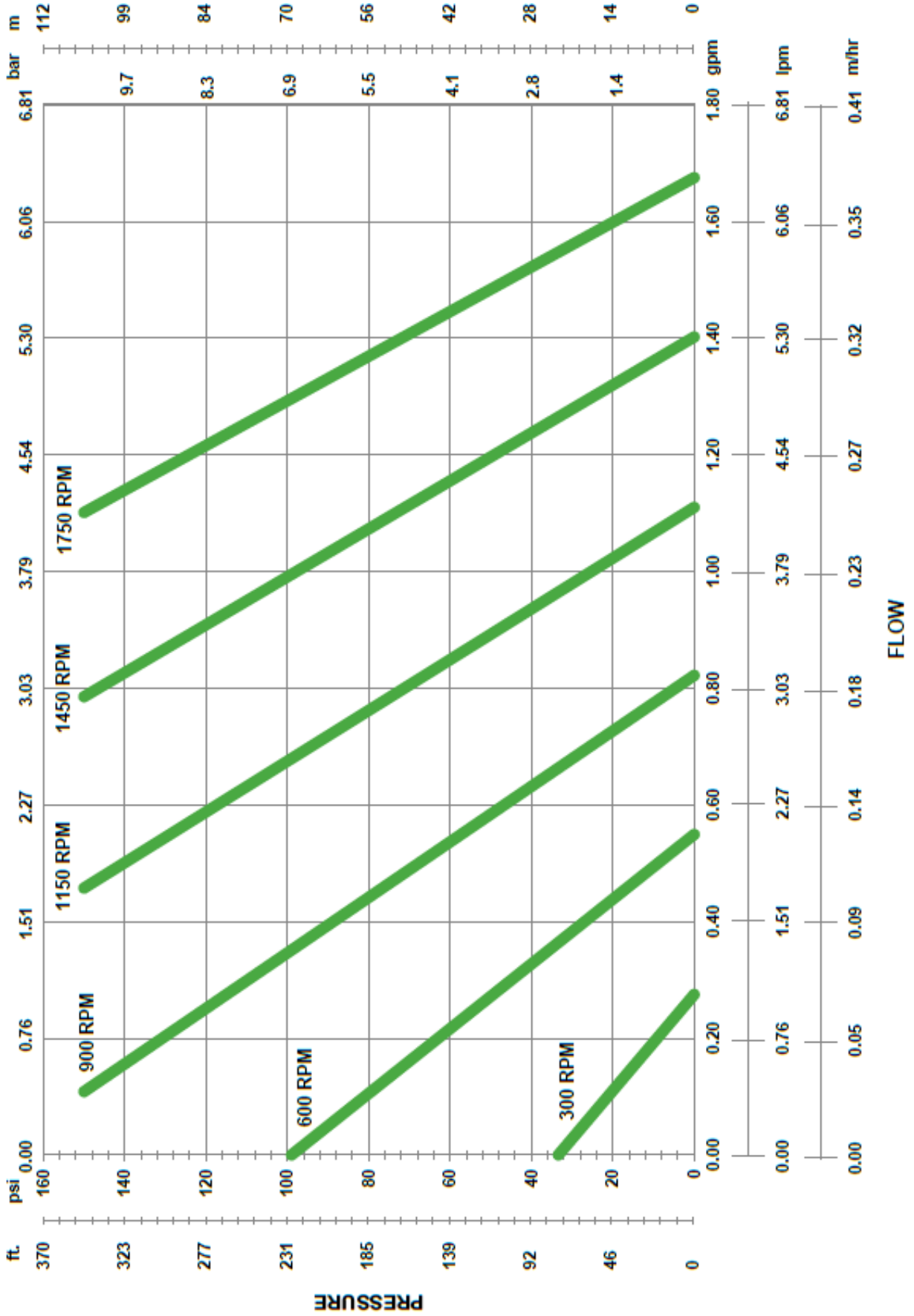

20.3 E12

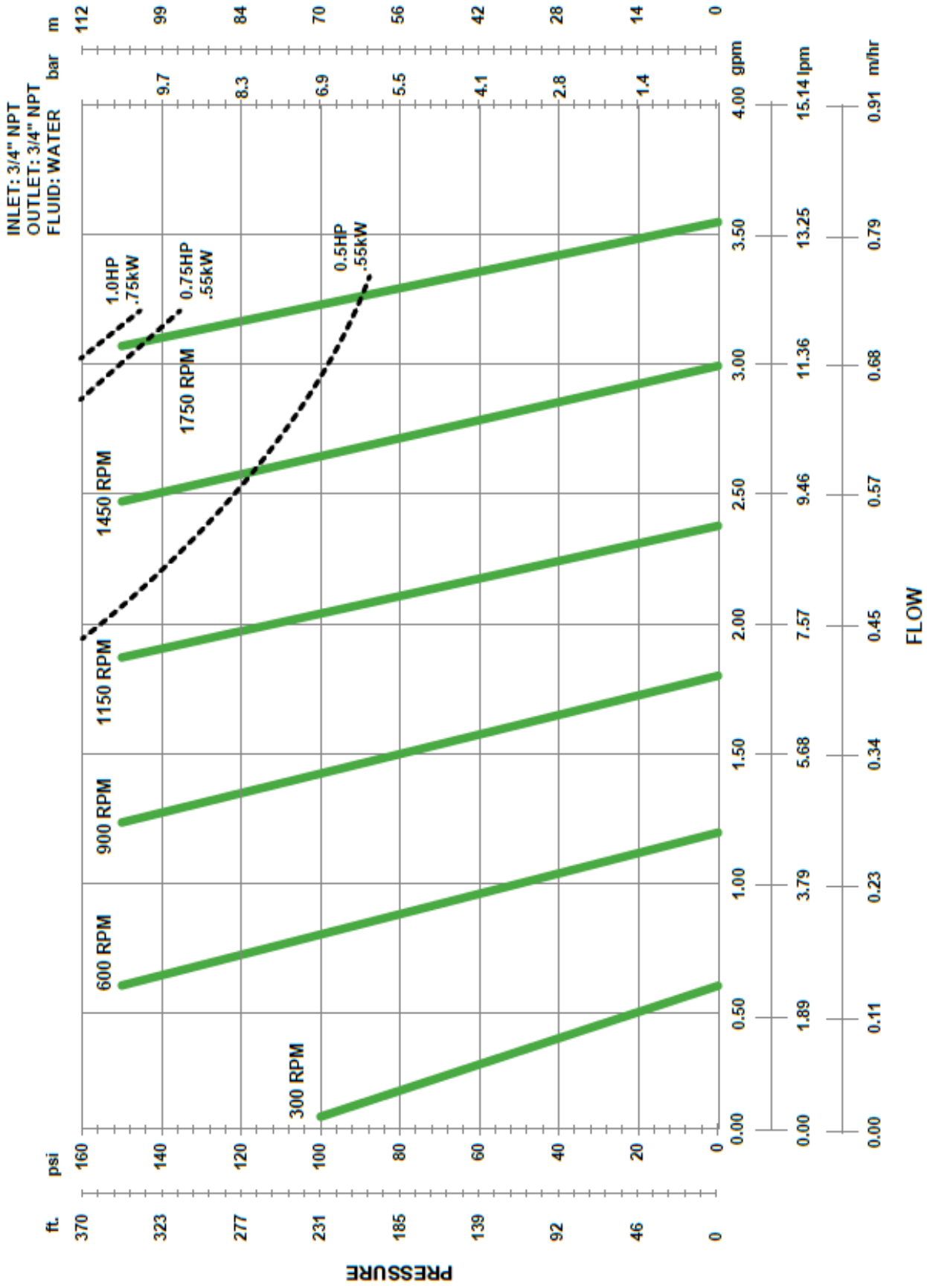

20.4 E25

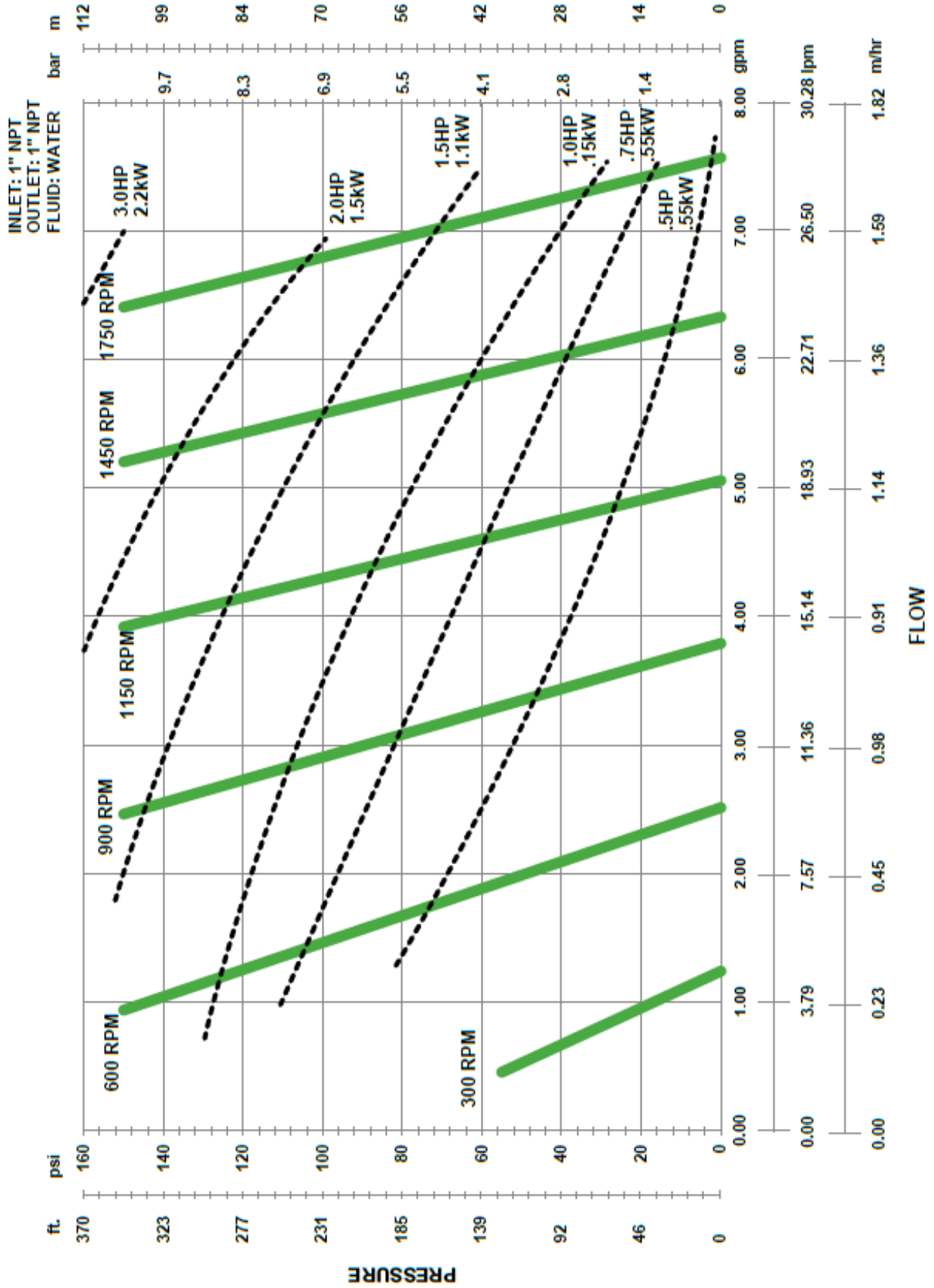

20.5 E75

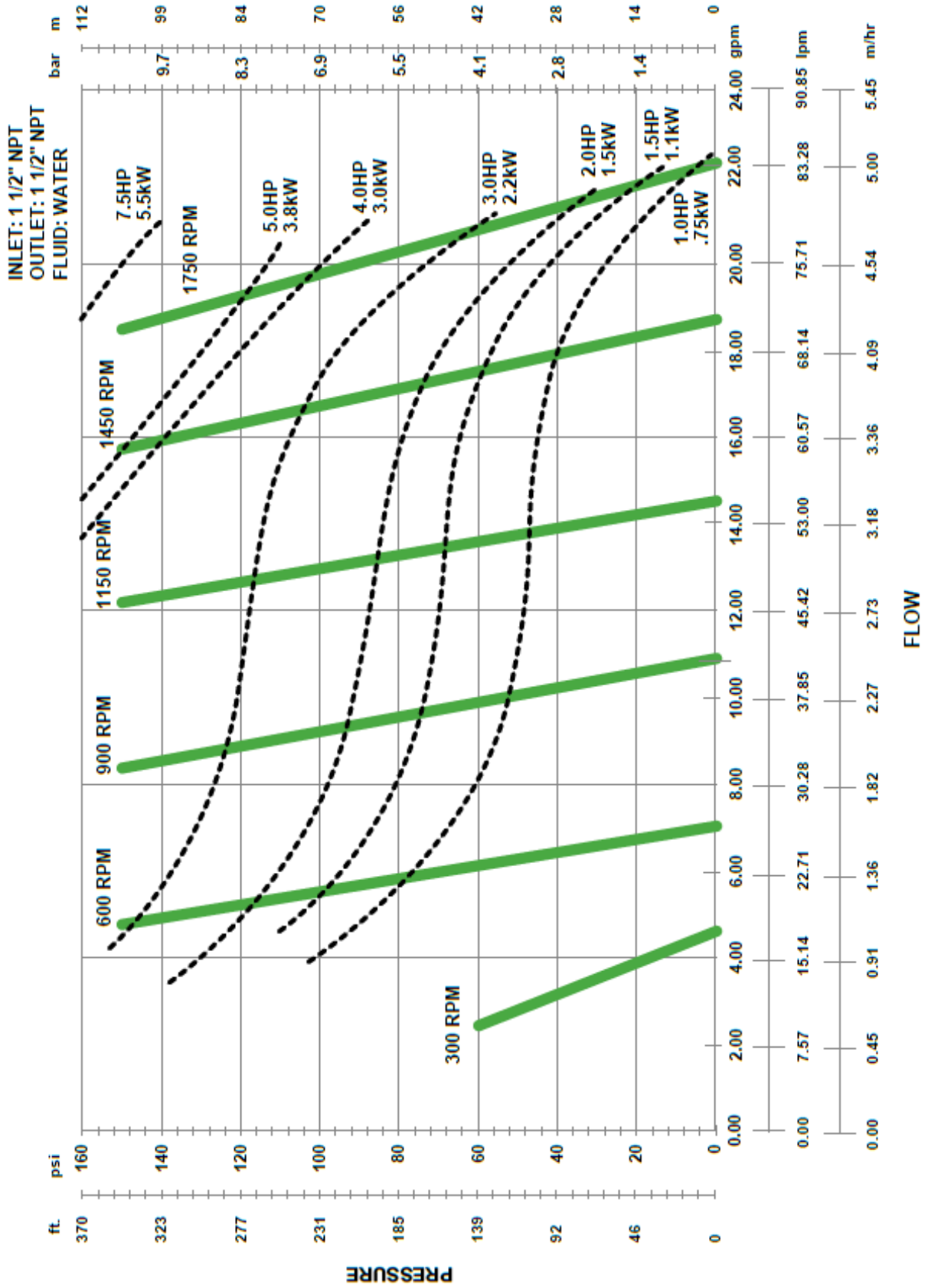

20.6 E125

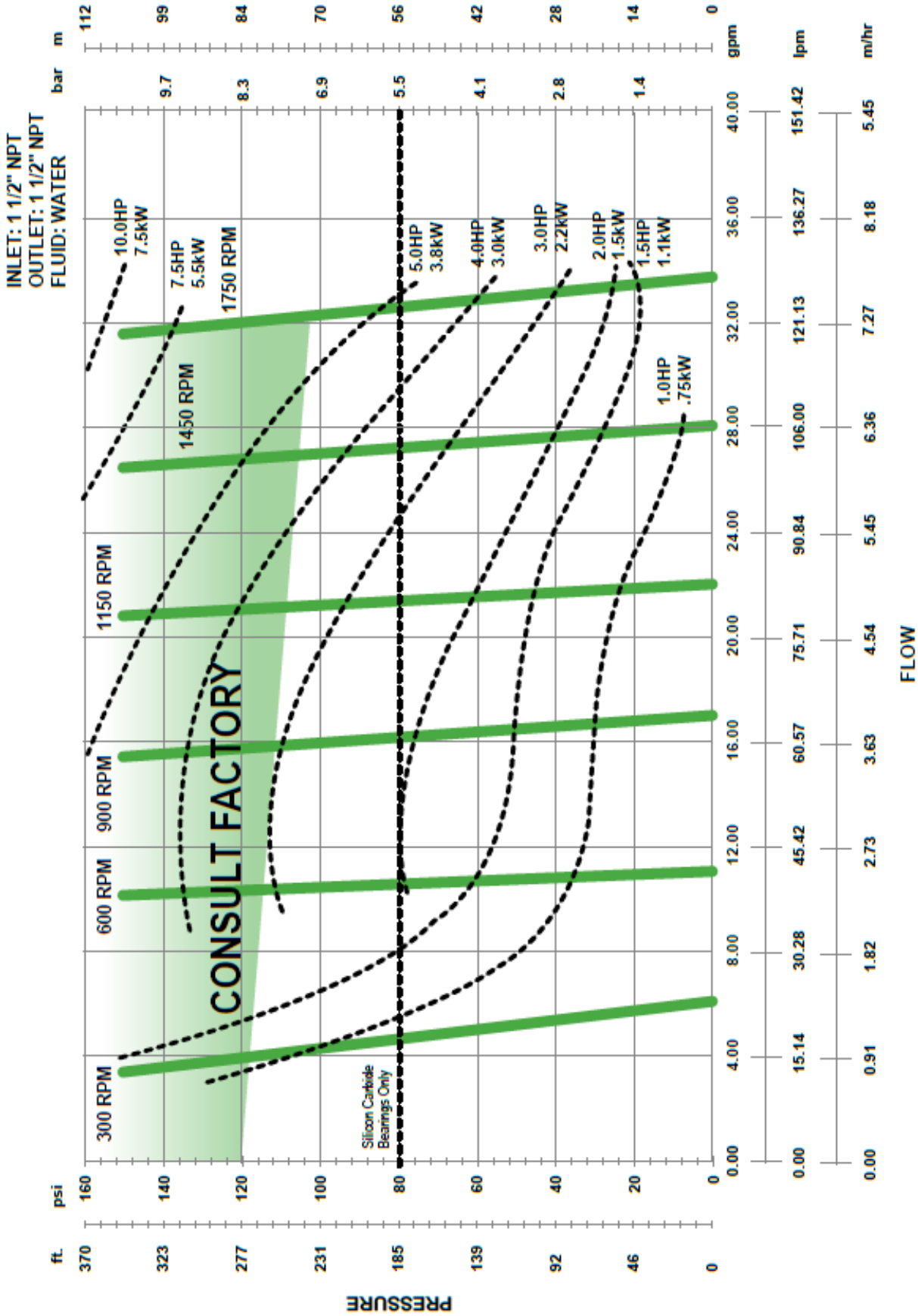

21. ATEX Directive

ECO / ISOCHEM / ECLIPSE IOM ADDENDUM

ATEX Directive 94/9/EC

Potentially Explosive Atmospheres

NP550110-IOM REV B

8/10/2005

Scope

This addendum is to the Installation, Operation and Maintenance Manual of the ECO, Isochem and Eclipse Gear Pump family of pumps. It includes all the necessary additional information to be considered when installing these pump models in a potentially explosive environments (Group II, Category 2, G & D).

Models Included in the Assessment

G , GA and GC series ECO Mechanical sealed gear pumps

GM and GMC Isochem Magnetically driven gear pumps

E Series Eclipse Magnetically driven gear pumps

Description of Equipment

The general product description for this equipment is positive displacement external gear pumps. They are supplied as mechanically sealed and magnetically driven versions.

Intended Usage of the Equipment

ECO / Isochem / Eclipse gear pumps are intended to be used to transfer various fluids. With proper sensors or feedback devices they can also be used to meter fluids.

Pulsafeeder has decided to construct the pumps to meet the requirements for Group II, category 2 equipment. To meet Category 2 equipment requirements, all possible ignition sources that can occur in normal operation of the pumps and additionally, those that can become effective as a result of malfunctions expected to occur in service must be considered. As the pumps are not intended to meet the requirements of category I, potential ignition sources arising from rare malfunctions can be neglected.

Reference Standards

97/38/EC Machinery safety directive

EN 13463-1 (2001) Non-electrical equipment for potentially explosive atmospheres - Part 1: Basic method and requirements

EN 1127-1 Explosive atmospheres - Explosion prevention and protection - Part I: Basic concepts and methodology

EN 60529 Degrees of protection provided by enclosures (IP Code)

Equipment

Equipment in Group II, Category 2, is intended for use in areas in which explosive atmospheres caused by gases, vapors, mists or air/dust mixtures are likely to occur.

G & D Atmospheres

In G type Explosive atmosphere (Gas, vapor, mist) equipment is suitable for use in Zone 1 areas.

In D type Explosive atmosphere (Dust) equipment is suitable for use in Zone 21 areas.

Temperature Class

Temperature class TX based on ambient and pumped fluid temperature.

Different temperature classes can be achieved based on fluid and ambient temperatures (See chart)

Temperature Class and Maximum Liquid Temperatures

Temperature Class	Maximum Surface Temperature C Permitted (Dust)	Max. Liquid or Ambient Temperature C		Comments
		Sealed Pumps	Magnetic Drive	
T1	450	260	230	Fluid temperatures are limited by pump construction
T2	300	225	225	
T3	200	145	145	
T4	135	90	90	
T5	100	65	65	
*T6	85	50	50	Normal class rating

* Maximum Temperature Class for Eclipse Series Pumps is T6.

Technical Support & Service

For technical support or service contact:

Pulsafeeder Inc.

2883 Brighton Henrietta Townline Road

Rochester, New York

14623

USA

(585) 292-8000

Protective Earth Ground

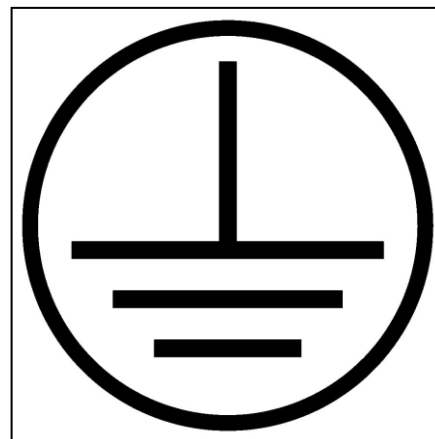

Sample Tag



Tech. File Ref.: XXXXXXXX-XXX Mfg. Date: XX/XX/XX
Mfg. Location: Rochester, NY USA 14623-2909

Additional Equipment

Additional equipment such as a Power Monitor, Temperature probe and a Flow meter should be fitted at all times when using a pump in a potentially explosive atmosphere. The pump / unit must also be "Earth Grounded" at all times. **A pump should never be "Run Dry" especially in Potentially Explosive Atmospheres.**

General Usage Precautions

1. The pump must be "Earth Grounded" at all times to prevent Electrostatic charge build up. (When an ATEX approved pump is requested, a "Ground" contact point is provided or identified by the protective earth ground symbol.) The electrical installation must conform to all location relevant codes.
2. The pump must not be used beyond its ratings and if the original operating conditions change, it is the users responsibility to check with Pulsafeeder to confirm if the pump is still acceptable for the new operating conditions.
3. Pulsafeeder will only consider the pump safe for the purpose and duty conditions originally specified by the purchaser. Pulsafeeder will not accept responsibility for pump failure or personal injury arising from mis-application of the product.
4. In the event of any one of the following conditions occurring the pump should be shut down and the cause investigated and rectified.
 - Unaccountable rise in discharge pressure
 - Release of liquid from the pressure relief mechanism
 - Excessive noise emissions
 - Unaccountable rise in operating temperature
 - Excessive power consumption
 - Loss of flow
5. Unauthorized modification or use of components other than original Pulsafeeder spares revokes any liability for consequences, which may result.
6. A pressure relief method must be used at the discharge of the pump to provide over pressure protection. For ATEX Potentially Explosive Atmospheres, a "return to tank type piping system" is recommended to prevent high temperatures due to recycled fluid.

7. Pumps cannot be driven by belts or chains.
8. Lubricate Power Frames if used with the appropriate lubricant specified in the standard instructions.
9. Check any gear reducers, motor, couplings, etc for instructions and lubricate as recommended.
10. Packing should not be used in potentially explosive environments. Packing adjustment is critical to prevent high surface temperatures. Packing must leak to cool itself.
11. Care must be exercised on the initial start of a new pump to prevent dry running. The pump can not tolerate dry run for more than a few seconds. Even after initial break in, pumps must not run dry as high temperatures can happen very quickly.
12. Inspecting the pump for internal wear regularly. Look for signs of heavy grooving, galling, twisting or breakage. These are the signs that rapid wear has taken place. This is a good indication that the pump may not be a good match for the service conditions. Rapid wear could result in unexpected failure that could be the source of ignition of the explosive environment.
13. The purchaser/user must ensure that all maintenance work including disassembly and reassembly is carried out by authorized and qualified personnel, who are sufficiently trained in the operation of the pump.
14. Due to the tight internal tolerances of a gear pump the most reliable way of repairing a pump is by the use of a KOPkit, which contains all the normal wear parts to restore the pump to like new condition.
15. Make sure that heavy deposits of dust are not allowed to accumulate. Clean pump periodically.
16. Don't run the pump faster or at a higher pressure than rated.
17. Don't flush the pump with steam or air without protecting against shaft rotation due to the gears in the pump being forced to turn like a turbine.
18. The use of a power, pressure and temperature monitoring of the pump and system is highly recommended.
19. Refer to the provided temperature table for information relating to ambient and fluid temperatures.
20. Properly vent or flush the pump of fluids or gasses before disassembling for service.
21. Obtain, read and keep maintenance instructions furnished with the pump.

Normal Operation

More detailed information is supplied in the Installation, Operation, and Maintenance manual.

Potential Ignition Source	Measures to take to prevent the source from becoming effective
Frictional ignition	<p>All moving parts in the pumps are submersed in the pumped fluid, which acts as a lubricant and coolant. Do not run the pump dry.</p> <p>Packing is not recommended for Explosive environments due to the possibility of high temperature in the area of the stuffing box due to mis-adjustment. If packing is used, thermal monitoring is required to meet ATEX requirements</p>
Pump bearings	<p>Verify pump turns freely</p> <p>The use of a strainer is recommended</p> <p>The use of bearing flushing is recommended</p> <p>The bearing housings need to be examined for signs of overheating, abnormal noise, or discoloration on a daily basis. Alternatively continuous temperature monitoring can be fitted and set to trip the drive power at 10 C above normal baseline temperature</p> <p>Monitor pump frequently when pumping non-lubricating fluids</p>
Power frame bearings	<p>Check lubricant level weekly and monitor for leaks daily</p>
Dust deposits on pump	<p>Regular cleaning is needed to prevent deposits from accumulating in a thickness great enough to become an ignition hazard</p>
Static electricity discharge	<p>The pump must be grounded (bonded) at the "Protective Earth Ground" location marked on the pump</p> <p>Vent cavities to prevent Oxygen / Air build up</p>
High temperatures	<p>Recommend Temperature monitors</p> <p>Recommend Flow indicator</p> <p>Recommend Power monitor</p> <p>Recommend Pressure switch</p>
Use of electric motor	<p>If an electric motor is used as a driver for the pump, it must be ATEX approved for the environment</p>

Expected Malfunction

Potential Ignition Source	Measures to take to prevent the source from becoming effective
Dry run	<p>All moving parts in the pumps are submersed in the pumped fluid, which acts as a lubricant and coolant. Do not run the pump dry.</p> <p>Recommend Power monitor Recommend Flow indicator Recommend Pressure switch Recommend Temperature monitors</p>
Pump bearings	<p>Max. radial wear on bearings is .13 mm (.005 in)</p> <p>Monitor pump daily when pumping non-lubricating fluids for high temperatures at bearing bosses</p> <p>Every 1000 hours inspect the pump for wear and rebuild with a KOPkit if necessary</p> <p>Typical life of the pump bearings is 2000 hours. Regular maintenance and good record keeping will provide a more accurate service interval</p>
Power frame bearings	<p>Check condition of lip seals for the power frame every month to insure lubricant containment</p>
High temperature	<p>Recommend Temperature monitors Recommend Flow indicator Recommend Pressure switch Recommend Power monitor</p>



ECLIPSE[®]

EXTERNAL GEAR METERING PUMP

Bulletin: IOM-ECL-3500-Rev.H



Pulsafeeder, Inc.
A unit of IDEX Corporation
2883 Brighton Henrietta Town Line Road
Rochester NY 14623
+1 (585) 292-8000
www.pulsa.com
pulsa@idexcorp.com



AUSTRALIAN DISTRIBUTOR



CALL 1300 789 466
When Pump Knowledge Matters
www.kelairpumps.com.au