

Set-up and programming guide

HYDROVAR[®]

HV 2.015-4.220
software
for compatibility to
HV 2.1-3.22

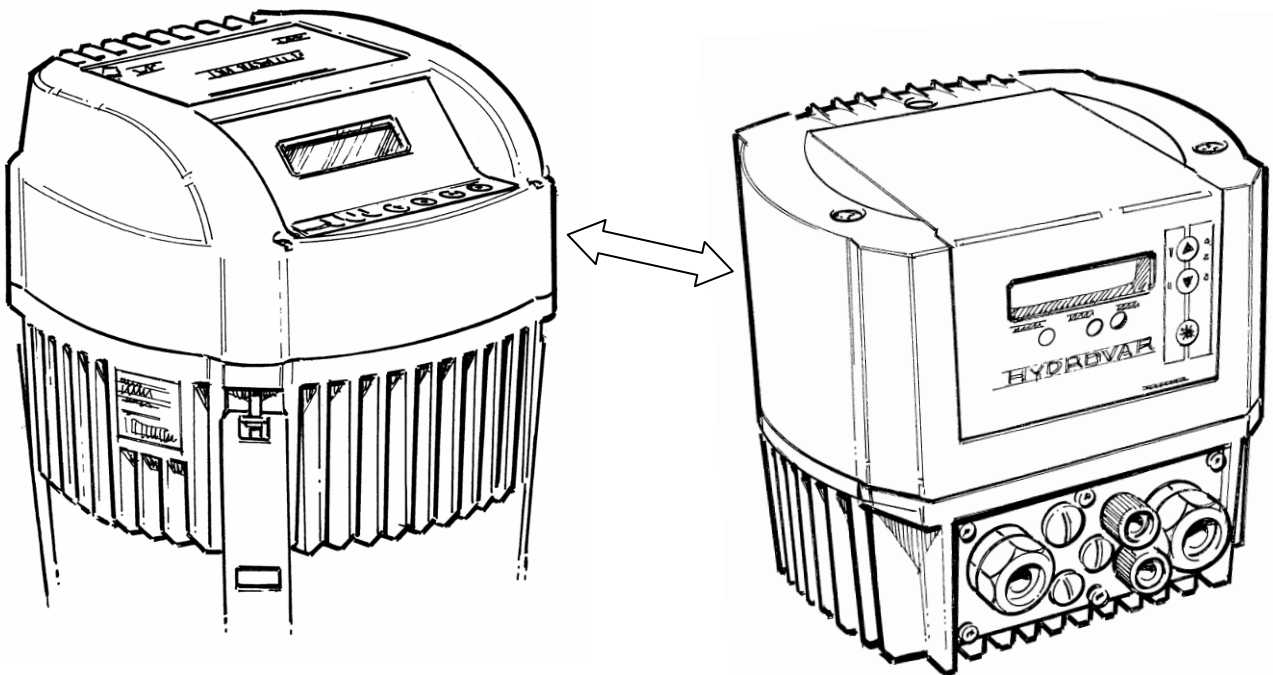



xylem

Index

1 Important safety instructions	2
2 General information	5
2.1 Overview	5
2.2 Restrictions.....	5
2.3 Software definition and functionality	5
2.4 Cross reference list HV 2.1-3.22 vs. HV 2.015-4.220.....	5
3 Technical Data	6
4 Preparing the HV for compatibility function	6
4.1 Control card I/O's	7
4.2 Control terminals	7
4.3 Comparison between HV 2.1-3.45 and HV 2.015-4.220 compatibility	8
5 Programming	13
5.1 Display – control panel of the HV 2.015–4.220	13
5.2 Start up guide	14
5.3 System and application specific parameter settings.....	16
6 Failure messages	17
7 Programming flow chart HV 2.015-4.220 compatibility	18
8 Programming flow chart HV 2.1–3.45 vs. HV 2.015–4.220 compatibility	20

Follow the pump operating and maintenance instructions
We reserve the right to alter specifications

1 Important safety instructions

	Read and follow the operating and safety instructions carefully before starting operations! All modifications must be done by qualified technicians!	
---	---	---



Warning that failure to observe the precaution may cause electric shock



Warning that failure to observe the precaution may cause personal injury or damage to property.

In addition to these operating instructions please pay attention to universal safety and accident prevention regulations.

Basically the HYDROVAR must be disconnected from the power supply before any work can be carried out on the electrical or mechanical part of the system. Installation, maintenance and repair work may be carried out only by trained, skilled and qualified personnel.

Unauthorized modification or changes to the system make all guarantees null and void.

During operation, the motor can be stopped by opening a digital input or manual operation whereby the HYDROVAR and the motor remain under voltage. For safety reasons, the HYDROVAR has to be disconnected from the power supply when carrying out work on the machinery.



When the HYDROVAR is connected to the power supply, the components of the power unit as well as certain components of the control unit are connected directly to the mains.

Touching these components seriously endangers life!

Before removing the HYDROVAR cover the system must be disconnected from the power supply. After switching off the power supply wait **at least 5 minutes** before starting work on or in the HYDROVAR (the capacitors in the intermediate circuit are discharged by the internal discharge resistors).

Voltages of up to 800 volts are possible (in case of error these also can be higher)

All work, carried out on the HYDROVAR, may only be performed by qualified and authorized staff.

Furthermore, take care not to short circuit the neighbouring components when connecting the external control wires. All cable ends which are not in use have to be isolated.



The HYDROVAR contains electronic safety devices which switch off the control element in the event of a fault, whereby the motor has zero current but remains energised and comes to a halt. The motor can also be halted by mechanical blocking. If it is switched off electronically the motor is current less from the mains voltage through the electronics of the HYDROVAR but is not potential-free in the circuit.

In addition voltage fluctuations, especially power failures can cause the system to switch itself off.

Repair of faults can cause the motor to start up again automatically!



The system may only be put into operation when it has been grounded. In addition to that, equipotential bonding of all conductive pipes must be ensured.

Please consider local installation standards!



High voltage tests of the HYDROVAR or the motor may damage the electronic components! Hence bridge the in- and outgoing terminals L1 - L2 - L3 / U-V-W before.

To avoid incorrect metering by capacitors incorporated in the electronic part isolate the motor from the HYDROVAR.



The operating instructions must be read, understood and followed by the operating personnel. We point out that we accept no liability for damage and operating disorders which are the result of non-compliance with the operating instructions.



Transport, handling, storage, disposal:

- Check the HYDROVAR immediately after delivery/receipt for damage or missing parts
- The HYDROVAR unit must be transported carefully.
- Avoid serious impacts

NOTICE!

Dispose of all packing materials and the HYDROVAR unit in accordance with local regulations. For more detailed information about the recycling of this product, please contact your local authority, your waste disposal service provider or the outlet where you purchased the product.

CAUTION!



Lifting aids (stacker, crane, crane mounting device, lifting blocks, sling ropes, etc.) must be suitable to handle the weight of the HYDROVAR.

CAUTION!



It is not allowed to carry the HYDROVAR around by using the connected cables.

Do not damage the cable during transport (do not squeeze, bend or drag). The cable ends must be kept dry.

WARNING!



- Do not stand underneath suspended loads
- Take note of the general regulations on prevention of accidents
- The HYDROVAR must be secured against tipping over and slipping until it has been fixed in its final location.

2 General information

2.1 Overview

The compatibility software is a specific software version which can be used together with the HYDROVAR product range HV2.015-4.220.

It has been developed to enable the above mentioned HYDROVAR types to be full replacement to the former product range HV2.1-3.22 especially in multi pump systems. I.e. together with this software the HV2.015-4.220 can completely replace a failed HV2.1-3.22 or simply extend an already existing HV2.1-3.22 equipped pump system.

2.2 Restrictions

To ensure the compatibility function, this software must be already installed on the control card. With the standard software version (V01.x) this functionality can not be provided and therefore the HV2.015-4.220 units must be prepared accordingly (either by installing the software directly on the control card or replacing the complete control with one where the software is installed – for more detailed information reg. these possibilities refer to page 6).

2.3 Software definition and functionality

The compatibility software C01.x can be easily identified by its item name and version number. Pls. find the following description for clear identification and differentiation to the standard version.

V01.x¹ – standard software version

C01.x¹ – specific compatibility version

¹(x)... stands for the release number, e.g. C01.4

The functions of the compatibility software C01.x are based on the HV VOG120x2 software version that is standard on all HV2.1-3.22 units. However the parameter structure and navigation is the same than on the V01.x menu structure.

2.4 Cross reference list HV 2.1-3.22 vs. HV 2.015-4.220

The following table gives an overview about the HYDROVAR replacement types:

previous (e,f)		replacement with	
HV	software version		HV
2.1		C01.X	2.015-M3-5-x-1000-G-1-V
2.2	114,		2.022-M3-5-x-1000-G-1-V
3.2	120a,		4.022-M3-5-x-1000-G-1-V
3.3	120b,		4.030-M3-5-x-1000-G-1-V
3.4	120c,		4.040-M3-5-x-1000-G-1-V
3.5	120d,		4.055-M3-5-x-1000-G-1-V
3.7	120b1,		4.075-M3-5-x-1000-G-1-V
3.11	120b2,		4.110-M3-5-x-1000-G-1-V
3.15	120d1,		4.150-M3-5-x-1000-G-1-V
3.18	120d2		4.185-M3-5-x-1000-G-1-V
3.22			4.220-M3-5-x-1000-G-1-V

3 Technical Data

For all main technical data and detailed information reg. installation as well as power supply connection, please refer to the standard HYDROVAR manual, version "Manual HV 2.015-4.220", chapters 5 to 9.

4 Preparing the HV for compatibility function

To enable a standard HV2.015-4.220 unit for compatibility function, following options are available:

- **Exchange the control card by a compatibility replacement card**

The control cards (one for HV2.015-4.110 and one for HV4.150-4.220 due to different hardware versions) with the compatibility software already installed are available as standard spare parts and can be ordered directly. After replacing the original control card of a HV2.015-4.220 the unit will then automatically start up with the appropriate software and can be directly integrated to an existing HV2.1-3.22 system.

C01.x



V01.x



How to change the control card can be read out in the document

AI_SpareParts_accessories_HV2.015-4.220

- **Install the compatibility software directly on the original control card**

How to run the installation process and what is needed therefore can be read out in the document

OI_Software_update_HV2.015-4.220

4.1 Control card I/O's

When using the compatibility software with the HYDROVAR HV2.015-4.220 the control card terminals are automatically re-configured to provide the same I/O's like the control cards of the HYDROVAR HV2.1-3.22 series.

4.2 Control terminals

All control cables connected to the control card have to be screened.
External volt free contacts must be suitable for switching <10 VDC.



NOTE: If unscreened control cables are used, signal interference may occur and could also interfere incoming signals and the function of the HYDROVAR.

Do not connect the ground of the control card to other voltage potentials.
All electronic ground terminals and GND of the RS 485-interface are connected internally.

- The control card is connected to the power unit via a ribbon cable on terminal X8.
- The display is connected to terminal X9.
The display can be mounted in normal position (0°) or upside down (180°) – for HV2.015-4.110.
- The connection terminals X6 and X7 can be used if optional boards are available.
E.g. the additional relay card can be connected to the control card at connection slot X6.

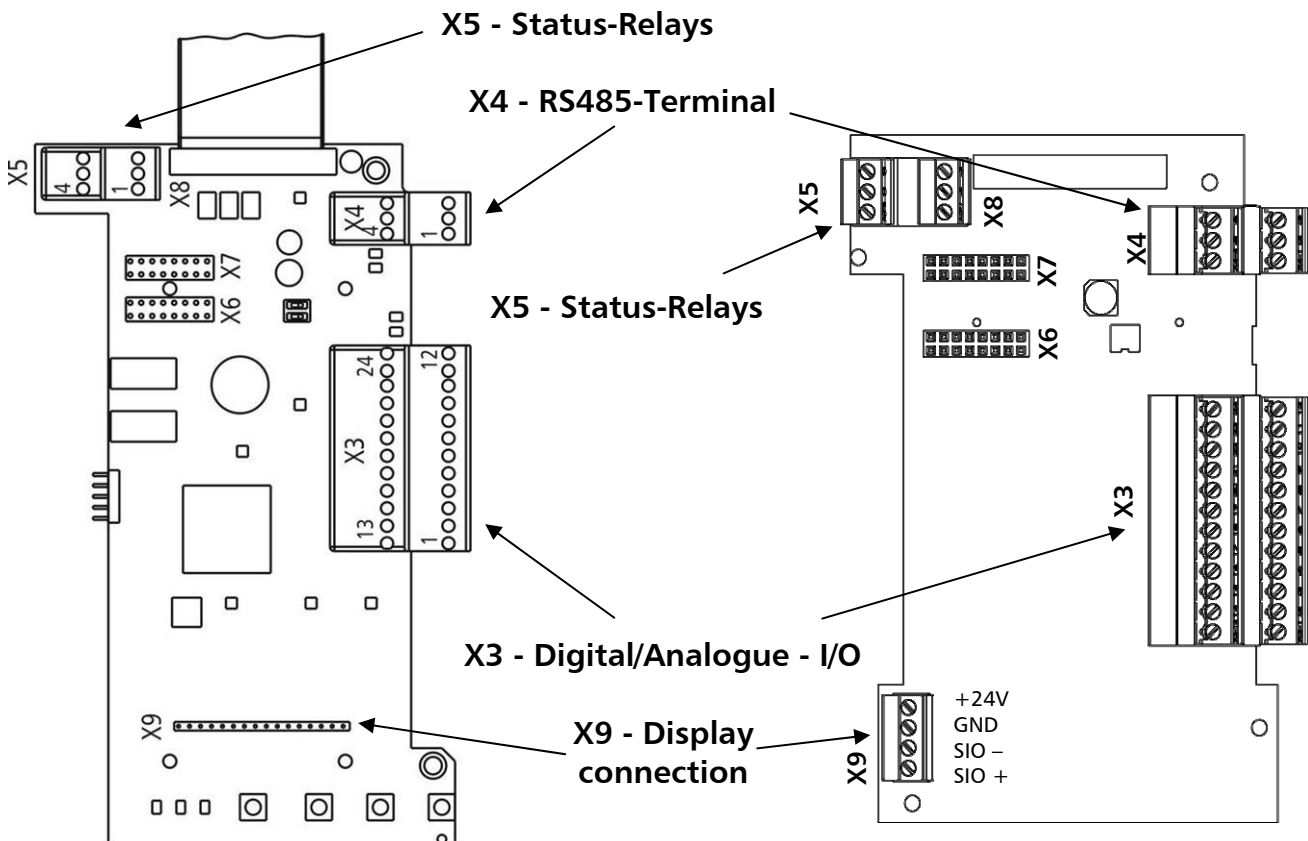

4.3 Comparison between HV 2.1-3.45 and HV 2.015-4.220 compatibility

		HV 2.1-3.45	Digital and Analogue I/O	
			HV 2.015-4.220	
X1/	X3/	Description		Notes
1	1	GND, electronic ground		
2	2	Actual value current input sensor		4-20mA [Ri=50Ω]
3	3	Power supply for external sensors		24VDC ² - HV 2.015-4.220 15VDC - HV2.1-3.45
	4	Not used		
	5	Not used		
	6	Not used		
5	7	External ON/OFF (release)		Active low
4	8	GND, electronic ground		
14	9	Configurable digital input		Active low
	10	GND, electronic ground		
7	11	Low water		Active low
6	12	GND, electronic ground		
13	13	Voltage signal input for Offset function		0-10VDC
	14	GND, electronic ground		
13	15	Voltage signal input for 2 nd required value		0-10VDC
	16	GND, electronic ground		
	17	GND, electronic ground		
12	18	Current signal input for Offset function		4-20mA [Ri=50Ω]
	19	Not used		
11	20	Analogue output 1 (actual value / Frequency)		0-10VDC, max. 2mA
	21	Not used		
	22	GND, electronic ground		
12	23	Current signal input for 2 nd required value		4-20mA [Ri=50Ω]
	24	+24V power supply for control inputs		24VDC ¹

² X3/3 and X3/24 → Σ max. 100mA

Control terminals for HV 2.1-3.22

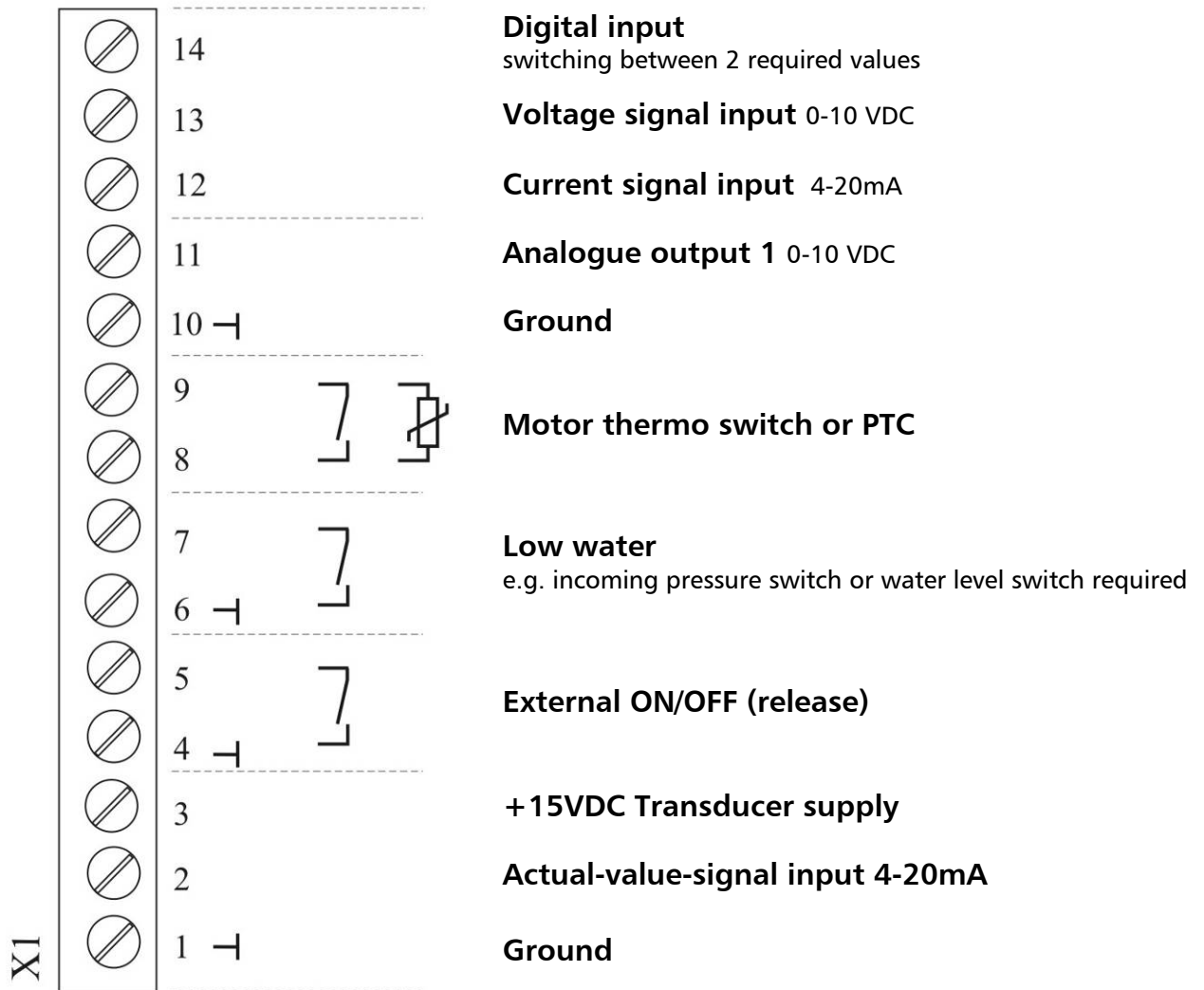

Control terminals for HV 2.015-4.220 with compatibility software C01.x

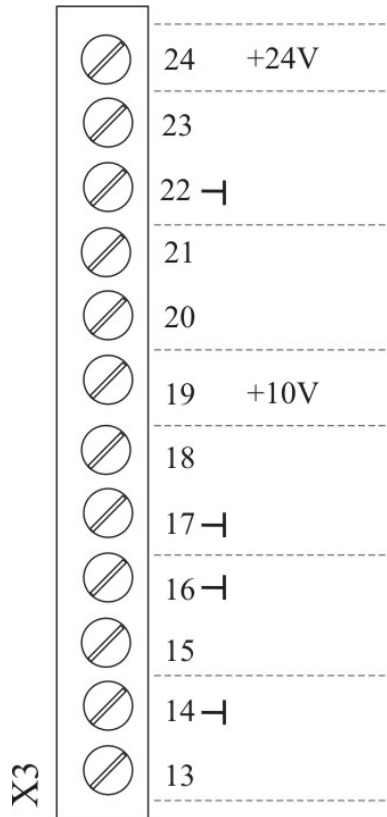

Additional power supply

Current signal input (required val. 2) 4-20mA [Ri=50Ω]
To determine the required value

Not used

Analogue output 0-10 VDC

Not used

Current signal input (Offset) 4-20mA [Ri=50Ω]
To determine the offset

Voltage signal input (required value 2) 0-10 VDC
To determine the offset

Voltage signal input (Offset) 0-10 VDC
To determine the offset

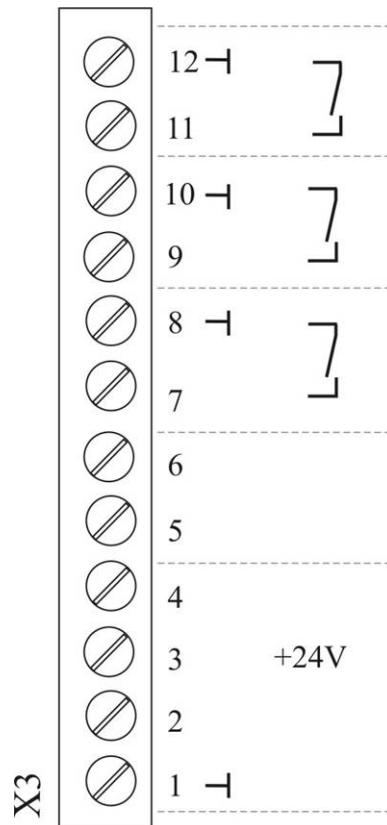

Low water
e.g. incoming pressure switch or water level switch required

Digital input
switching between 2 required values

External ON/OFF (release)

Not used

Not used

Not used

Sensor supply

Actual-value-current input sensor 1 4-20mA [Ri=50Ω]

Ground

Internal interface connection

X4 RS485-Interface			
X4/	1	Internal SIO-Interface: SIO-	} Internal interface for multi-pump-systems
	2	Internal SIO-Interface: SIO+	
	3	GND, electronic ground	
X4/	4	-	} Not used
	5	-	
	6	-	



The **internal RS-485 Interface** is used for the communication between up to 4 HYDROVAR units in a multi-pump application. For the connection of each HYDROVAR via the RS-485 interface the terminals X4/1-3 on the control card (HV2.015-4.220) and either the terminals X5/1-3 or X6/1-3 on the control card (HV2.1-3.22) have to be used.

Connection example: using one HV2.015-4.220 and two HV2.1-3.22

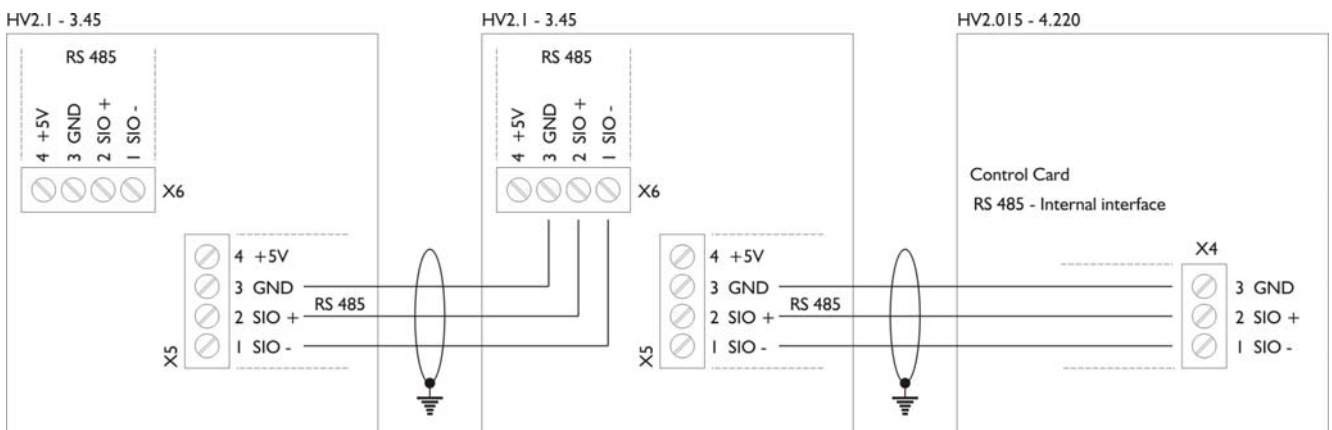

Status relays

X5 Status-Relays					
X5/	1	Fault signal	CC	} [Max. 250VAC] [0,25A] [Max. 220VDC] [0,25A] [Max. 30VDC] [2A]	
	2		NC		
	3		NO		
4	Pump running signal	CC			
5		NC			
6		NO			

Fault signal

Pump running signal

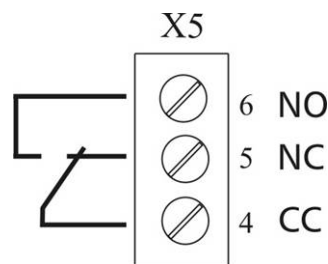
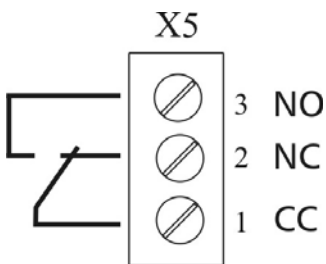

Notice:

When using the relay contacts for driving an external relay, a corresponding RC-snubber-circuit or varistor is necessary, to prevent disturbance of the HYDROVAR!

Connection examples:

Fault signal	Pump running signal
<p>Ext. 250VAC / 220VDC</p>	<p>Ext. 250VAC / 220VDC</p>
X5/ 1 and 2 closed: if there is a fault	X5/ 4 and 6 closed: motor run indication

5 Programming

5.1 Display – control panel of the HV 2.015–4.220

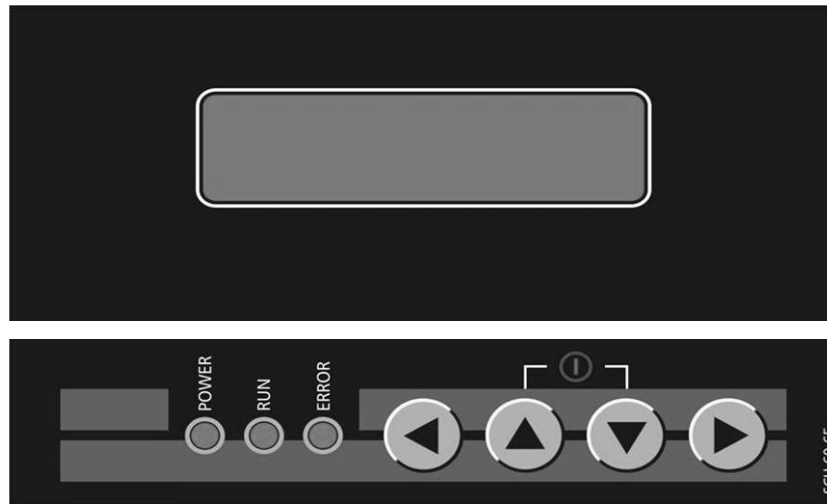

Function of the push buttons

- ▲ Start the HYDROVAR in the 1st Window
- ▼ Stop the HYDROVAR in the 1st Window
- ◀ and ▶ Reset: by pressing both buttons simultaneously for 5 seconds
- ▲ Increase of a value / selection of the submenu
- ▼ Decrease of a value / selection of the submenu
- ▲ + short ▼ Change to faster scrolling up of a value
- ▼ + short ▲ Change to faster scrolling down of a value
- ▶ Short press: enter submenu / Change to next parameter in the menu
- ◀ Short press: leave submenu / Change to previous parameter in the menu
- ▶ Long press: Acknowledgement of a determined action
- ◀ Long press: Change back to the sub menu

5.2 Start up guide

To integrate HV2.015-4.220 to an existing pump system which consists of older HYDROVAR units (HV2.1-3.22) the following programming steps need to be done:

NOTICE! Changes will not be saved automatically in case of a disconnection of the power supply!

Step 1: Check software version

For HV2.015-4.110:

0202	0202 SOFTWARE HV C01.4	Software version of the control board
------	---------------------------	---------------------------------------

For HV4.150-4.220:

0202	0202 SW RD V01.0 HV C01.4	Software version of the remote display (RD) and the control board (HV)
------	------------------------------	--

Step 2: Language selection

05	05 LANGUAGE ENGLISH	Language selection
----	------------------------	--------------------

Possible settings: EN, DE, IT, FR, NL, PT, ES, RU, PL	To select the desired language press ▲ or ▼
--	---

NOTICE! This compatibility software only supports the standard languages which are also available for the HV2.1-3.22.

Step 3: Select operating mode

0105	0105 MODE Controller	Selection of the operation mode
------	-------------------------	---------------------------------

Possible settings: Controller, Actuator, Multicontroller, Manual Control, Synchronous Controller
--

For multi pump systems either select "Multicontroller" or "Synchronous Controller"

NOTICE! The selected operation mode must be the same which is used on the existing HYDROVAR units.

Step 4: Set the right address

0106	0106 PUMP ADDR. 1	Selection of the right address
------	----------------------	--------------------------------

Possible settings: 1-4 To select the desired address press ▲ or ▼

NOTICE! Each address may only be used once!

Step 5: Harmonize / Synchronize actual value reading (e.g. pressure signal)

Zero point adjustment (4mA) of the transducer: Necessarily required for multi pump applications.

Make sure that the system is not pressurized.

0430	0430 SENS 1 CAL 0 Press > for 3sec	Actual value sensor zero point calibration
------	---------------------------------------	--

Press ► button for approx. 3 sec. until the message "DONE" is shown

0430	Not available Press > for 3sec	Actual value sensor zero point calibration
------	-----------------------------------	--

This message appears when the presence of residual pressure in the system does not allow calibration of the zero point. Depressurize the system completely and repeat the adjustment.

Due to the different hardware versions between the control cards the display indication of the actual value may still vary between the existing HYDROVAR units and the implemented one(s). Therefore an additional adjustment/synchronization of the sensor signal can be done by the use of the following parameter:

0435	0435 SENS 1 CAL X 0.0 _ actual value	Sensor 1 upper range value calibration
------	---	--

Possible settings: - 5.0% to +5.0%

During normal operation of the HYDROVAR unit an offset value between -5.0% to +5.0% of the actual value reading can be set. This adjustment of the actual value can be done by pressing the ▲ and ▼ button till the reading is equal to the other HYDROVAR units in the system.

Step 6: Save parameters

NOTICE! Changes will not be saved automatically in case of a disconnection of the power supply!

All values must be saved (stored in an EEPROM) after changing.
If they aren't saved, all changes will be lost in case of a power failure!

To reach the SAVE parameter, following ways are feasible:

First way (from the main menu)

Direct selection of parameter [19] SAVE

19	19 SAVE Press > for 3 sec	Save
----	------------------------------	------

Press ► button for approx. 3 sec. until the message "DONE" is shown

Second way (from the secondary menu)

To leave the selected menu after changing parameters, the ◀ button must be pressed till the first parameter of this submenu is shown. Then the button must be shortly released but pressed again (◀ button) to reach the parameter [19] SAVE.

Press ► button for approx. 3 sec. until the message "DONE" is shown.

NOTICE! Even after successful saving procedure the display will still show "Press > for 3 sec"!

After following the steps above the HYDROVAR should now be successfully integrated to the existing system.

Pls. check proper communication by pump sequence indication on all the HYDROVAR units (P1....P4) and change required value to see if it is automatically transferred to all connected units.

5.3 System and application specific parameter settings

After the successful integration of the compatible HYDROVAR unit(s) all other parameters must be adopted to the existing system. Therefore either the settings must be read out from one existing HYDROVAR unit or a list of parameter settings (e.g. commissioning protocol) is available.

To set the parameters accordingly please refer to the parameter overview in chapters 7 to 8. Additionally more detailed information can be found in the standard HYDROVAR manual, version "Manual HV 2.1-3.45", chapters 8 to 9.

NOTICE! The parameter "Relay Config" is not available in the compatibility software version

Following parameters don't need to be changed as they are transferred automatically once the compatible HYDROVAR units is successfully integrated to the existing system and communication over the pump interface works properly:

02	02 REQUIRED VAL 1 X.XX Bar	Set the desired required value with ▲ or ▼
0330	0330 LIFT AMOUNT 30.0 %	Lift amount for required lift value
0500	0500 SUBMENU SEQUENCE CNTR.	All the parameters within this submenu are automatically transferred
0820	0820 REQ.VAL.1 XX.X Bar	Required value 1 (digital)
0825	0825 REQ.VAL.2 XX.X Bar	Required value 2 (digital)

6 Failure messages



If the HYDROVAR is stopped by an error (warning), the HYDROVAR and the motor remain under voltage.

Before any work is carried out on the electrical or mechanical part of the system, the HYDROVAR must be disconnected from power supply.

The failure handling of the compatibility software is based on the standard software of the HV2.1-3.22. For more details pls. refer to the "Manual HV 2.1-3.45", chapter 10.

Each error is shown on the display in plain text and saved in the error memory.

The errors can be reset automatically (depending on the setting in parameter ERROR-RESET [0615]) or manually in following ways:

- cutting the power supply for > 60 seconds
- pressing ◀ and ▶ simultaneously for about 5 seconds
- open and close the External ON/OFF (Terminals X3/7-8)

7 Programming flow chart HV 2.015-4.220 compatibility

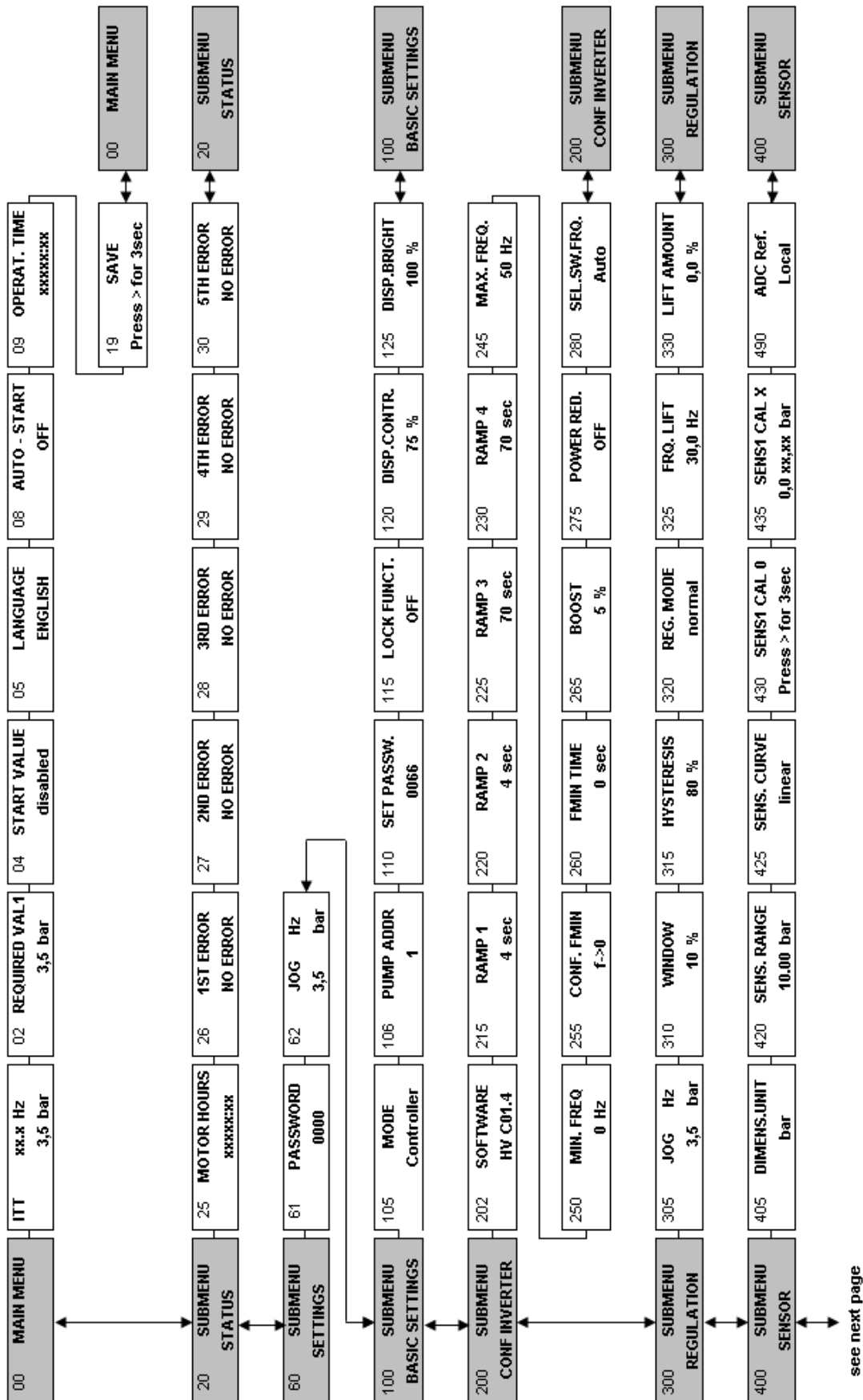

see next page

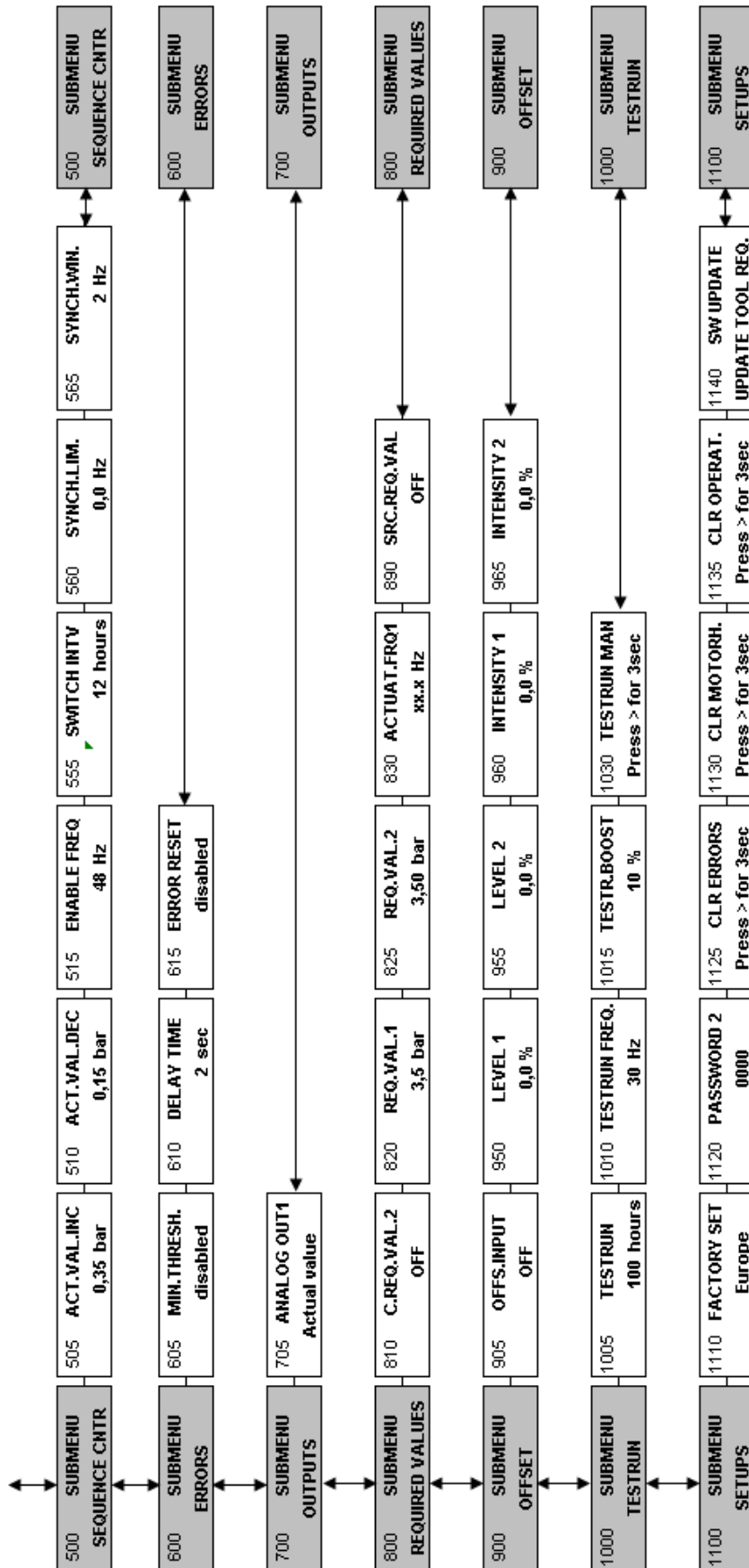

xylem

AUSTRALIAN DISTRIBUTOR



KelairPumps

CALL 1300 789 466

When Pump Knowledge Matters

www.kelairpumps.com.au

XYLEM WATER SOLUTIONS AUSTRIA GMBH

Ernst-Vogel Strasse 2

2000 Stockerau

Österreich

Telefon: +43 (0) 2266 / 604

Telefax: +43 (0) 2266 / 65311

e-mail: info.austria@xyleminc.com

web: www.xylemaustria.com

Xylem Water Solutions Austria GmbH reserves the right to make modifications without prior notice.

© 2012 Xylem, Inc