

**HYDROVAR<sup>®</sup>**

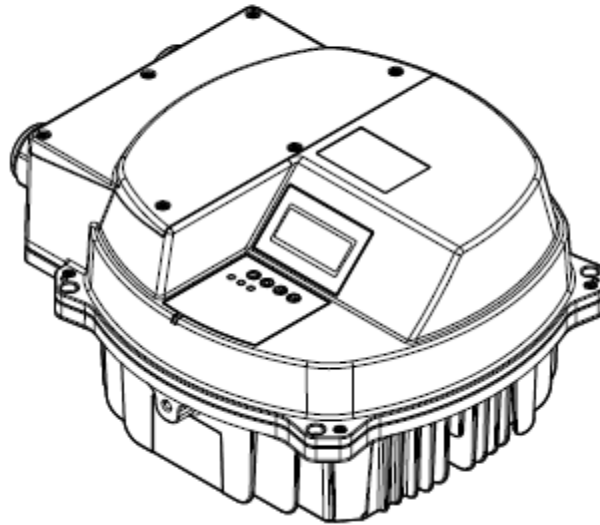

# HVL 2.015 – 4.220

## Bacnet Protocol & Objects

HVL Software Version: 2.00



Revision history

Date	Version	Notes	Author
December 12 <sup>th</sup> 2016	A	First release	Florian Çule



# 1 Index

<b>1</b>	<b>Index .....</b>	<b>3</b>
<b>2</b>	<b>Purpose of this document.....</b>	<b>4</b>
<b>3</b>	<b>Legend .....</b>	<b>4</b>
<b>4</b>	<b>BACnet Protocol Implementation Conformance Statement (PICS).....</b>	<b>5</b>
4.1	Product model number.....	5
4.2	HVL description .....	6
4.3	BACnet standardized device profile (Annex L) .....	6
4.4	BACnet interoperability building blocks supported (Annex K): BIBB.....	6
4.4.1	Data sharing .....	6
4.4.2	Alarm and event management .....	7
4.4.3	Scheduling .....	7
4.4.4	Trending .....	7
4.4.5	Device & Network Management .....	7
4.4.6	Network Management .....	8
4.5	Standard object types supported .....	8
4.6	Segmentation capability.....	8
4.7	Data Link Layer options .....	8
4.8	Device address binding.....	9
4.9	Networking options .....	9
4.10	Network security options.....	9
4.11	Character sets supported .....	9
<b>5</b>	<b>“BACnet Device” and “BACnet Device Object” Identifier.....</b>	<b>10</b>
5.1	BACnet Device Object Identifier .....	10
5.2	Hydrovar MAC address.....	10
<b>6</b>	<b>BACnet Virtual Memory.....</b>	<b>11</b>
6.1	Virtual Memory – Analog Values table.....	11
6.2	Virtual Memory – Analog Inputs table .....	16



## 2 Purpose of this document

The purpose of this document is to provide a list and a simple explanation of the BACnet objects implemented in the “Hydrovar” electronic drive.

For further information related to the BACnet standard protocol, refer to “**ANSI/ASHRAE Standard 135-2004, BACnet A Data Communication Protocol For Building Automation and Control Networks**” document or latest version of the same.

## 3 Legend

MS/TP	<b>Master-Slave / Token Passing</b>
UART	<b>Universal Asynchronous Receiver/Transmitter</b>
MIN	<b>Minimum</b>
MAX	<b>Maximum</b>
DEF	<b>Default</b>
R	<b>Readable</b>
R/W	<b>Readable &amp; Writable</b>
RPM	<b>Revolutions per Minute</b>
Q	<b>Flow</b>
H	<b>Head</b>
P	<b>Power</b>
PROP.	<b>Proportional</b>
W	<b>Watt</b>
A	<b>Ampere</b>
LSW / MSW	<b>Least Significant Word / Most Significant Word</b>
PWR	<b>Power</b>
FW	<b>Firmware</b>
KI	<b>Integral constant</b>
KP	<b>Proportional constant</b>
EIA	<b>Electronic Industries Alliance</b>
N.U.	<b>Not Used</b>
N.D.	<b>Not Defined</b>
N.A.	<b>Not Accessible</b>
N.P.	<b>Not Present</b>



## 4 BACnet Protocol Implementation Conformance Statement (PICS)

<b>DATE</b>	6 December 2016
<b>VENDOR NAME</b>	Xylem
<b>PRODUCT NAME</b>	Hydrovar
<b>PRODUCT MODEL NUMBER</b>	HVL see below table
<b>APPLICATION SOFTWARE VERSION</b>	V02.00
<b>FIRMWARE REVISION</b>	V1.00
<b>BACNET PROTOCOL VERSION</b>	1

### 4.1 *Product model number*

Hydrovar is a range of variable speed drives based on the same software; the PICS is the same for all products listed below.

PRODUCT
HVL 2.015
HVL 2.022
HVL 2.030
HVL 2.040
HVL 3.015
HVL 3.022
HVL 3.030
HVL 3.040
HVL 3.055
HVL 3.075
HVL 3.110
HVL 4.015
HVL 4.022
HVL 4.030
HVL 4.040
HVL 4.055
HVL 4.075
HVL 4.110
HVL 4.150
HVL 4.185
HVL 4.220



## 4.2 HVL description

Hydrovar is a variable frequency drive. Being equipped with advanced communication capabilities, the drive can be used as a stand-alone or network device with BACnet communication

## 4.3 BACnet standardized device profile (Annex L)

<input type="checkbox"/>	BACnet Advanced Workstation	(B-AWS)
<input type="checkbox"/>	BACnet Operator Workstation	(B-OWS)
<input type="checkbox"/>	BACnet Operator Display	(B-OD)
<input type="checkbox"/>	BACnet Building Controller	(B-BC)
<input type="checkbox"/>	BACnet Advanced Application Controller	(B-AAC)
<input type="checkbox"/>	BACnet Application Specific Controller	(B-ASC)
<input type="checkbox"/>	BACnet Smart Sensor	(B-SS)
<input checked="" type="checkbox"/>	BACnet Smart Actuator	(B-SA)

## 4.4 BACnet interoperability building blocks supported (Annex K): BIBB

### 4.4.1 Data sharing

<input type="checkbox"/>	Data Sharing – Read Property-A	DS-RP-A
<input checked="" type="checkbox"/>	Data Sharing – Read Property-B	DS-RP-B
<input type="checkbox"/>	Data Sharing – Read Property Multiple-A	DS-RPM-A
<input type="checkbox"/>	Data Sharing – Read Property Multiple-B	DS-RPM-B
<input type="checkbox"/>	Data Sharing – Write Property-A	DS-WP-A
<input checked="" type="checkbox"/>	Data Sharing – Write Property-B	DS-WP-B
<input type="checkbox"/>	Data Sharing – Write Property Multiple-A	DS-WPM-A
<input type="checkbox"/>	Data Sharing – Write Property Multiple-B	DS-WPM-B
<input type="checkbox"/>	Data Sharing – Change of Value-A	DS-COV-A
<input type="checkbox"/>	Data Sharing – Change of Value-B	DS-COV-B
<input type="checkbox"/>	Data Sharing – Change of Value Property-A	DS-COVP-A
<input type="checkbox"/>	Data Sharing – Change of Value Property-B	DS-COVP-B
<input type="checkbox"/>	Data Sharing – Change of Value Unsolicited-A	DS-COVU-A
<input type="checkbox"/>	Data Sharing – Change of Value Unsolicited-B	DS-COVU-B
<input type="checkbox"/>	Data Sharing – View-A	DS-V-A
<input type="checkbox"/>	Data Sharing – Advanced View-A	DS-AV-A
<input type="checkbox"/>	Data Sharing – Modify-A	DS-M-A
<input type="checkbox"/>	Data Sharing – Advanced Modify-A	DS-AM-A



**4.4.2 Alarm and event management**

N.P.

**4.4.3 Scheduling**

N.P.

**4.4.4 Trending**

N.P.

**4.4.5 Device & Network Management**

<input type="checkbox"/>	Device Management – Dynamic Device Binding-A	DM-DDB-A
<input checked="" type="checkbox"/>	Device Management – Dynamic Device Binding-B	DM-DDB-B
<input type="checkbox"/>	Device Management – Dynamic Object Binding-A	DM-DOB-A
<input type="checkbox"/>	Device Management – Dynamic Object Binding-B	DM-DOB-B
<input type="checkbox"/>	Device Management – Device Communication Control-A	DM-DCC-A
<input type="checkbox"/>	Device Management – Device Communication Control -B	DM-DCC-B
<input type="checkbox"/>	Device Management – Private Transfer-A	DM-PT-A
<input type="checkbox"/>	Device Management – Private Transfer-B	DM-PT-B
<input type="checkbox"/>	Device Management – Text Message-A	DM-TM-A
<input type="checkbox"/>	Device Management – Text Message-B	DM-TM-B
<input type="checkbox"/>	Device Management – Time Synchronization-A	DM-TS-A
<input type="checkbox"/>	Device Management – Time Synchronization-B	DM-TS-B
<input type="checkbox"/>	Device Management – UTC Time Synchronization-A	DM-UTC-A
<input type="checkbox"/>	Device Management – UTC Time Synchronization-B	DM-UTC-B
<input type="checkbox"/>	Device Management – Reinitialize Device-A	DM-RD-A
<input type="checkbox"/>	Device Management – Reinitialize Device-B	DM-RD-B
<input type="checkbox"/>	Device Management – Backup and Restore-A	DM-BR-A
<input type="checkbox"/>	Device Management – Backup and Restore-B	DM-BR-B
<input type="checkbox"/>	Device Management – Restart-A	DM-R-A
<input type="checkbox"/>	Device Management – Restart-B	DM-R-B
<input type="checkbox"/>	Device Management – List Manipulation-A	DM-LM-A
<input type="checkbox"/>	Device Management – List Manipulation-B	DM-LM-B
<input type="checkbox"/>	Device Management – Object Creation and Deletion-A	DM-OCD-A
<input type="checkbox"/>	Device Management – Object Creation and Deletion-B	DM-OCD-B
<input type="checkbox"/>	Device Management – Virtual Terminal-A	DM-VT-A
<input type="checkbox"/>	Device Management – Virtual Terminal-B	DM-VT-B
<input type="checkbox"/>	Device Management – Automatic Network Mapping-A	DM-ANM-A
<input type="checkbox"/>	Device Management – Automatic Device Mapping-A	DM-ADM-A



<input type="checkbox"/>	Device Management – Automatic Time Synchronization-A	DM-ATS-A
<input type="checkbox"/>	Device Management – Manual Time Synchronization-A	DM-MTS-A

#### 4.4.6 Network Management

N.P.

#### 4.5 Standard object types supported

OBJECT TYPE	SUPPORTED	CREATED/DELETED DYNAMICALLY	OPTIONAL PROPERTIES SUPPORTED	WRITABLE PROPERTIES
Analog Input (*)	<input checked="" type="checkbox"/>	<input type="checkbox"/>	Description	
Analog Value (**)	<input checked="" type="checkbox"/>	<input type="checkbox"/>	Description	
Device	<input checked="" type="checkbox"/>	<input type="checkbox"/>	Description, Max_Master, Max_Info_Frames	<b>Object_Identifier</b>

(\*) See par. 6.2 for further specification

(\*\*) See par. 6.1 for further specification

#### 4.6 Segmentation capability

N.P.

#### 4.7 Data Link Layer options

<input type="checkbox"/>	BACnet IP, (Annex J)	
<input type="checkbox"/>	BACnet IP, (Annex J), Foreign Device	
<input type="checkbox"/>	ISO 8802-3, Ethernet (Clause 7)	
<input type="checkbox"/>	ANSI/ATA 878.1, 2.5Mb. ARCNET (Clause 8)	
<input type="checkbox"/>	ANSI/ATA 878.1, 2.5Mb. ARCNET (Clause 8), baud rate(s)	
<input checked="" type="checkbox"/>	MS/TP master (Clause 9), baud rate(s)	9600 14400 19200 38400 (*) 57600 76800 115200
<input type="checkbox"/>	MS/TP slave (Clause 9), baud rate(s)	
<input type="checkbox"/>	Point-To-Point, EIA 232 (Clause 10), baud rate(s)	
<input type="checkbox"/>	Point-To-Point, modem (Clause 10), baud rate(s)	
<input type="checkbox"/>	LonTalk (Clause 11), medium	
<input type="checkbox"/>	Other	

(\*) It's suggested to set a baud rate equal or greater than 38400bps to avoid timing issues



**4.8 Device address binding**

Is static device binding supported? (required for two-way communication between MS/TP slaves and other devices)	<input type="checkbox"/> Yes	<input checked="" type="checkbox"/> No
---	------------------------------	--

**4.9 Networking options**

N.P.

**4.10 Network security options**

N.P.

**4.11 Character sets supported**

<input checked="" type="checkbox"/> ISO 10640 (UTF-8)	<input type="checkbox"/> IBM	<input type="checkbox"/> ISO 8859-1
<input type="checkbox"/> ISO 10646 (UCS2)	<input type="checkbox"/> ISO 10646 (UCS4)	<input type="checkbox"/> JIS 6226



## 5 “BACnet Device” and “BACnet Device Object” Identifier

A "BACnetDevice" is any device, real or virtual, that supports digital communication using the BACnet protocol: hence HVL is a "BACnetDevice".

Each “BACnetDevice” contains exactly one Device Object, which is a standardized object whose properties represent the externally visible characteristics of a “BACnetDevice”

In case of Hydrovar connected to a local MS/TP network, each device can be uniquely located referring to (both):

- the Device Object\_Identifier (see par. 5.1)
- the MAC address (see par 5.2)

### 5.1 *BACnet Device Object Identifier*

For Hydrovar, each Device Object\_Identifier is factory pre-set to a default value = 84001 (decimal number).

In case the user needs to change/update the pre-set value of the Device Object\_Identifier, this can be done by using the provided “WriteProperty” Service onto the property “Object\_Identifier” of the Device Object. Refer to parameter P1221 and the Installation and Operational Manual.

### 5.2 *Hydrovar MAC address*

For Hydrovar, the MAC address corresponds to the Address available on the Sub-Menu of the Communication Settings: it is factory pre-set to a default value = 1. Refer to parameter P1205 and the Installation and Operational Manual.

The user has to verify that every Hydrovar connected to the same local MS/TP network is identified by a different Address: the procedure to change Address is described on the Drive Manual.



## 6 BACnet Virtual Memory

The complete data-set managed by HVL is accessible considering a BACnet virtual memory made exclusively of 2 objects: *Analog Values* (whose “Present\_Value” Property is readable and writable) and *Analog Inputs* (whose “Present\_Value” Property is readable).

### 6.1 Virtual Memory – Analog Values table

It is a set of Analogue Values objects, whose “Present\_Value” Property is readable and writable [R/W], used for *standard settings*: generally the same operations or functions a user can perform/activate through the user interface.

OBJECT_IDENTIFIER	OBJECT_NAME	UNITS	PRESENT_VALUE			Description
0	START VALUE	[%]	0	100	100	Percentage of setpoint
1	DATE	-	65792	1661738759	65792	32bit number to be interpreted in order to extract the date yyyy/mm/dd
2	TIME	-	0	1522491	0	32bit number to be interpreted in order to extract the time hh/mm/ss
3	AUTO-START	-	0	1	0	Enable automatic restart of the motor after power off 0 = Off 1 = On
4	MODE	-	0	4	0	Operating mode 0 = Controller 1 = Cascade Relay 2 = Cascade Serial 3 = Actuator 4 = Cascade Synchron
5	LOCK FUNCT.	-	0	1	1	Lock or unlock parameter settings in the menu 0 = Off 1 = On
6	DISP. CONTR.	[%]	0	100	50	Adjust the display contrast 0-100%
7	DISP. BRIGHT.	[%]	0	100	50	Adjust the display brightness 0-100%
8	MAX. UNITS	-	1	8	1	Maximum number of units that can operate simultaneously
9	RAMP1	[s]	1	250/1000	4/8/12	Fast acceleration time, maximum and default depending on HVL model
10	RAMP2	[s]	1	250/1000	4/8/12	Fast deceleration time, maximum and default depending on HVL model
11	RAMP3	[s]	1	1000	70	Slow acceleration time
12	RAMP4	[s]	1	1000	70	Slow deceleration time
13	RAMP FMIN A	[s]	10	250	20/40	Sets the ramp Fmin acceleration (fast running up time). Used when operating below MIN.FREQ (Obj_id 16) Default depending on HVL model



14	<b>RAMP FMIN D</b>	[s]	10	250	20/40	<b>Sets the ramp Fmin deceleration (fast running down time). Used when operating below MIN.FREQ (Obj_id 16).</b> Default depending on HVL model
15	<b>MAX. FREQ:</b>	[Hz]	30	70	50	<b>Maximum frequency</b>
16	<b>MIN. FREQ:</b>	[Hz]	0	MAX.FREQ. (Obj_id 15)	50	<b>Minimum frequency</b>
17	<b>CONF.MIN.</b>	-	0	1	0	<b>Defines the operation at minimum frequency</b> 0 = F->0 1 = F->Fmin
18	<b>FMIN TIME</b>	[s]	0	100	0	<b>Delay time before a shut-off</b>
19	<b>SKIP FRQ: CTR.</b>	[Hz]	0	70	0	<b>Skip frequency center</b>
20	<b>SKIP FRQ: RNG.</b>	[Hz]	0	5	0	<b>Skip frequency range</b>
21	<b>BOOST</b>	[%]	0	25	5	<b>Motor starting voltage in % of motor nominal voltage</b>
22	<b>KNEE FREQ.</b>	[Hz]	30	70	50	<b>Knee frequency, where HYDROVAR generates its maximum output voltage</b>
23	<b>CURR.LIM.FUNCT.</b>	-	0	1	0	<b>Activates (ON) or deactivates (OFF) the current limit functionality</b>
24	<b>CURR.LIM.SET.</b>	[%]	10	300	110	<b>Current limit for motor (in % of rated current)</b>
25	<b>WINDOW</b>	[%]	0	100	10	<b>Range for ramp control; from slow to fast.</b>
26	<b>HYSTERESIS</b>	[%]	0	100	80	<b>Hysteresis for ramp switching.</b>
27	<b>REG.MODE</b>	-	0	1	0	<b>Regulation mode</b> 0 = Normal 1 = Inverse
28	<b>FRQ. LIFT</b>	[Hz]	0	70	30	<b>Frequency limit for the required lift value</b>
29	<b>LIFT AMOUNT</b>	[%]	0	200	0	<b>Lift amount for the required lift value in HVAC systems or for compensation of friction losses</b>
30	<b>DIMENSION UNIT</b>	-	0	12	0	<b>Unit of measure for the system</b> 0 = bar 1 = psi 2 = m <sup>3</sup> /h 3 = g/min 4 = m H <sub>2</sub> O 5 = ft 6 = °C 7 = °F 8 = l/s 9 = l/min 10 = m/s 11 = - 12 = %
31	<b>CONF.SENSOR</b>	-	0	7	0	<b>Configure the sensors</b> 0 = Sensor 1 1 = Sensor 2 2 = Auto 3 = Switch Dig 1



						4 = Switch Dig 2 5 = Auto lower 6 = Auto higher 7 = Sens1-Sens2
32	SENSOR TYPE	-	0	2	2	<b>Configure the sensors</b> 0 = Analog U 0-10V 1 = Analog I 0-20mA 2 = Analog I 4-20mA
33	SENSOR RANGE	[bar]	1	10000	1000	<b>Sensor range</b>
34	SENSOR CURVE	-	0	1	0	<b>Mathematical function (curve) to determine the Actual Value based on the Sensor signal</b> 0 = Linear 1 = Quadratic
35	SENS. 1 CAL.0	[%]	-10	10	0	<b>Calibrate the minimum value of Sensor 1</b>
36	SENS. 1 CAL.X	[%]	-10	10	0	<b>Calibrate the maximum value of Sensor 1</b>
37	SENS. 2 CAL.0	[%]	-10	10	0	<b>Calibrate the minimum value of Sensor 2</b>
38	SENS. 2 CAL.X	[%]	-10	10	0	<b>Calibrate the maximum value of Sensor 2</b>
39	ACT.VAL.INC.	[bar]	0	SENSOR RANGE (Obj_id 33)	0,35	<b>Sets the lift value</b>
40	ACT.VAL.INC.	[bar]	0	SENSOR RANGE (Obj_id 33)	0,15	<b>Sets the drop value</b>
41	ENABLE FRQ.	[Hz]	0	70	48	<b>The desired release frequency for the following pumps</b>
42	ENABLE DLY.	[s]	0	100	5	<b>Sets the enable delay time: the fixed-speed pump starts after the selected time. Cascade relay, only</b>
43	SWITCH DLY.	[s]	0	100	5	<b>Sets the switch delay time, thus avoiding repeated switching caused by consumption variation. Cascade relay, only</b>
44	DISABLE FRQ.	[Hz]	0	70	30	<b>Frequency to switch off the fixed speed pumps. Cascade relay, only</b>
45	DISABLE DLY.	[s]	0	100	5	<b>Delay time before switching off the assist pumps. Cascade relay, only</b>
46	DROP FRQ.	[Hz]	0	MAX:FREQ:	42	<b>Before the MASTER starts a new assist pump, it drops to this frequency. Cascade relay, only</b>
47	OVERVALUE	[bar]	0	SENSOR RANGE	0	<b>If this selected value is reached, an immediate shut-off of the follow-up-pumps is executed. Cascade relay, only</b>
48	OVERVAL.DLY.	[s]	0	10	0	<b>Delay time to switch off an assist pump in case the actual value exceeds OVERVALUE. Cascade relay, only</b>
49	SWITCH INTV.	[h]	0	250	24	<b>Interval for the cyclic change-over</b>
50	SYNCH.LIM.	[Hz]	0	MAX.FREQ. (Obj_id 15)	0	<b>The first assist pump shuts off if the frequency goes below</b>
51	SYNCH.WND.	[Hz]	0	10	2	<b>Frequency window: the limit for switching off the next assist pump</b>



52	<b>MIN.THRESH.</b>	[bar]	0	SENSOR RANGE (Obj_id 33)	0	Minimum threshold. If the value is not reached within the DELAY-TIME, the unit stops
53	<b>DELAY TIME</b>	[s]	0	100	2	Delay time of the minimum threshold limit: it shuts off the HYDROVAR if the actual value drops below <b>MIN.THRESH</b>
54	<b>ANALOG OUT 1</b>	-	0	1	1	Selects the first analog output, which is connected to terminal X3/3-4 on the Premim Card 0 = Actual value 1 = Output frequency
55	<b>ANALOG OUT 2</b>	-	0	1	0	Selects the first analog output, which is connected to terminal X3/5-6 on the Premim Card 0 = Actual value 1 = Output frequency
56	<b>CONF.REL 1</b>	-	0	5	1	Selects the status relay 1 0 = Power 1 = Running 2 = Errors 3 = Warnings 4 = Stand by 5 = Error reset
57	<b>CONF.REL 2</b>	-	0	5	2	Selects the status relay 2 0 = Power 1 = Running 2 = Errors 3 = Warnings 4 = Stand by 5 = Error reset
58	<b>C.REQ.VAL. 1</b>	-	1	4	1	Configures the required value 1 1 = Digital 2 = Analog U 0-10V 3 = Analog I 0-20mA 4 = Analog I 4-20mA
59	<b>C.REQ.VAL. 2</b>	-	0	4	0	Configures the required value 2 0= Off 1 = Digital 2 = Analog U 0-10V 3 = Analog I 0-20mA 4 = Analog I 4-20mA
60	<b>SW.REQ.VAL.</b>	-	0	3	0	Configures the switching between required value 1 and 2 0= Setpoint 1 1 = Setpoint 2 2 = Switch digital 1 3 = Switch digital 2
61	<b>REQ.VAL. 1</b>	[bar]	0	SENSOR RANGE (Obj_id 33)	3,5	Sets the digital required value 1 in bar
62	<b>REQ.VAL. 2</b>	[bar]	0	SENSOR RANGE (Obj_id 33)	3,5	Sets the digital required value 2 in bar
63	<b>ACTUAT.FRQ. 1</b>	[Hz]	MIN. FREQ (Obj_id 16)	MAX. FREQ. (Obj_id 15)	MIN. FREQ (Obj_id 16)	Set the required frequency 1 for Actuator mode
64	<b>ACTUAT.FRQ. 2</b>	[Hz]	MIN. FREQ (Obj_id 16)	MAX. FREQ. (Obj_id 15)	MIN. FREQ (Obj_id 16)	Set the required frequency 2 for Actuator mode



65	OFFS.INPUT	-	0	6	0	Selects the offset input 0 = Off 1 = Analog U1 0-10V 2 = Analog U2 0-10V 3 = Analog I1 0-20mA 4 = Analog I1 4-20mA 5 = Analog I2 0-20mA 6 = Analog I2 4-20mA
66	OFFSET RANGE	-	0	10000	100	Set the representation of the sensor range: the value depends on the maximum range of the connected offset sensor
67	LEVEL 1	-	0	10000	0	Selects the first level until the offset function 1 is active
68	OFFSET X1	-	0	10000	0	Sets the offset signal value (X1), which is a fixed point
69	OFFSET Y1	[bar]	0	SENSOR RANGE (Obj_id 33)	0	Set the maximum allowed pressure at OFFSET X1
70	LEVEL 2	-	0	10000	100	Selects the second limit where the offset function 2 starts to be active
71	OFFSET X2	-	0	10000	0	Sets the offset signal value (X2), which is a fixed point
72	OFFSET Y2	[bar]	0	SENSOR RANGE (Obj_id 33)	0	Set the required pressure at this flow rate.
73	TEST RUN	[h]	0	100	100	Starts up the pump after the last stop
74	TEST RUN FRQ.	[Hz]	MIN. FREQ. (Obj_id 16)	MAX.FREQ. (Obj_id 15)	30	Frequency for manual and automatic test run
75	TEST R.BOOST	[%]	0	25	10	Motor starting voltage as a percentage of the rated input voltage.
76	TEST R.TIME	[s]	0	180	5	Time for the test run.
77	AV00077	-	-	-	-	Reserved
78	AV00078	-	-	-	-	Reserved
79	PUMP ADDR.	-	1	8	1	Sets an address for each inverter
80	START UP COMPLETE?	-	0	1	0	Did you configure the inverter? 0 = No 1 = Yes
81	AV00081	-	-	-	-	Reserved
82	AV 00082	-	0	1	0	Enable Motor relay 1 0 = Disable 1 = Enable
83	AV 00083	-	0	1	0	Enable Motor relay 2 0 = Disable 1 = Enable
84	AV 00084	-	0	1	0	Enable Motor relay 3 0 = Disable 1 = Enable
85	AV 00085	-	0	1	0	Enable Motor relay 4 0 = Disable 1 = Enable
86	AV 00086	-	0	1	0	Enable Motor relay 5 0 = Disable 1 = Enable



## 6.2 Virtual Memory – Analog Inputs table

It is a set of Analogue Inputs objects, whose “Present\_Value” Property is readable [R], used for *standard settings*: generally the same data a user can acquire through the user interface.

OBJECT_IDENTIFIER	OBJECT_NAME	UNITS	PRESENT_VALUE			Description
0	ACTUAL VALUE	[bar]	0	SENSOR RANGE (Obj_id 33)	...	Pressure indication. See manual for further explanation
1	EFF.REQ.VAL.	[bar]	0	SENSOR RANGE (Obj_id 33)	...	Pressure indication. See manual for further explanation
2	STATUS DEVICE	-	0	9	...	<b>Status of the selected device</b> 0 = - 1 = Offline 2 = Preparing 3 = Disabled 4 = Stopped 5 = Running 6 = Solo run 7 = Fault 8 = Relay off 9 = Relay on
3	MOTOR HOURS	[h]	0	2147433275	...	<b>Operation time in hours of the selected device.</b> <b>32bit number to be interpreted to extract the hours hhhh/mm</b>
4	PROD. DATE	-	0	4294967295	...	<b>Production date of the control board; the display format is YYYYWW (year, week). . 32bit number to be interpreted to extract the hours yyyy/ww</b>
5	TEMP INVERTER	[°C]	-128	127	...	Temperature inside the selected unit
6	CURR. INVERTER	[A]	0	100	...	Output current for the selected unit
7	VOLT. INVERTER	[V]	0	1000	...	Input voltage for the selected unit
8	OUTPUT FREQ.	[Hz]	0	70	...	Output frequency for the selected unit
9	VER. INVERTER	-	0	4294967295	...	<b>information about the software version of the power board</b> <b>32bit number to be interpreted to extract the version code TT.BB</b>

