



ESH



ESHF
ESHHC

Applicare qui il codice a barre

Apply the adhesive bar code nameplate here

it	Manuale di installazione, uso e manutenzione..... 2	pl	Podręcznik instalacji, eksploatacji i konserwacji..... 179
en	Installation, Operation, and Maintenance Manual..... 14	cs	Návod k instalaci, provozu a údržbě..... 192
fr	Manuel d'installation, d'utilisation et d'entretien..... 25	sk	Návod na inštaláciu, obsluhu a údržbu....204
de	Montage-, Betriebs- und Wartungshandbuch38	hu	Beszerezési, működtetési és karbantartási útmutató.....216
es	Manual de instalación, funcionamiento y mantenimiento..... 51	ro	Manual de instalare, exploatare și întreținere228
pt	Manual de Instalação, Operação e Manutenção.....63	bg	Ръководство за Инсталиране, Експлоатация и Обслужване..... 241
nl	Handleiding voor installatie, bediening en onderhoud..... 76	sl	Navodila za vgradnjo, delovanje in vzdrževanje..... 254
da	Installations-, betjenings- og vedligeholdelseshåndbog 88	hr	Priručnik za instaliranje, rad i održavanje265
no	Installasjons-, drifts- og vedlikeholdshåndbok..... 100	sr	Priručnik za instaliranje, rad i održavanje276
sv	Installations-, drift- och underhållsmanual 111	el	Εγχειρίδιο εγκατάστασης, λειτουργίας και συντήρησης..... 288
fi	Asennus-, käyttö- ja huolto-opas..... 123	tr	Kurulum, Çalıştırma ve Bakım Kılavuzu.. 301
is	Handbók um uppsetningu, rekstur og viðhald..... 134	ru	Руководство по установке, эксплуатации и техническому обслуживанию..... 312
et	Paigaldamise, kasutamise ja hooldamise juhend..... 145	uk	Посібник зі встановлення, експлуатації та технічного обслуговування 325
lv	Uzstādīšanas, ekspluatācijas un tehniskās apkopes rokasgrāmata..... 156	ar	دليل التركيب والتشغيل والصيانة..... 338
lt	Montavimo, eksploataavimo ir techninės priežiūros vadovas..... 167		



Causa	Soluzione
	care le condizioni di esercizio della pompa (dislivelli, perdite di carico, temperatura del liquido, ecc...)
I cuscinetti del motore sono usurati.	Rivolgersi al rappresentante di vendita e assistenza di zona.
Presenza di corpi estranei all'interno della pompa.	Rivolgersi al rappresentante di vendita e assistenza di zona.
Il girante striscia contro l'anello di usura	Rivolgersi al rappresentante di vendita e assistenza di zona.

Causa	Soluzione
Giunto non allineato correttamente	Controllare l'allineamento del giunto.
Gli elementi flessibili del giunto sono usurati.	Controllare e sostituire le parti rilevanti in caso siano presenti segni di usura.

Per ogni situazione non contemplata, fare riferimento al rappresentante di vendita e assistenza di zona.

1 Introduction and Safety



1.1 Introduction

Purpose of this manual

The purpose of this manual is to provide necessary information for:

- Installation
- Operation
- Maintenance



CAUTION:

Read this manual carefully before installing and using the product. Improper use of the product can cause personal injury and damage to property, and may void the warranty.

NOTICE:

Save this manual for future reference, and keep it readily available at the location of the unit.

1.1.1 Inexperienced users



WARNING:

This product is intended to be operated by qualified personnel only.

Be aware of the following precautions:

- This product is not to be used by anyone with physical or mental disabilities, or anyone without the relevant experience and knowledge, unless they have received instructions on using the equipment and on the associated risks or are supervised by a responsible person.
- Children must be supervised to ensure that they do not play on or around the product.

1.2 Safety terminology and symbols

About safety messages

It is extremely important that you read, understand, and follow the safety messages and regulations carefully before handling the product. They are published to help prevent these hazards:

- Personal accidents and health problems
- Damage to the product and its surroundings
- Product malfunction

Hazard levels

Hazard level	Indication
DANGER:	A hazardous situation which, if not avoided, will result in death or serious injury
WARNING:	A hazardous situation which, if not avoided, could result in death or serious injury
CAUTION:	A hazardous situation which, if not avoided, could result in minor or moderate injury
NOTICE:	Notices are used when there is a risk of equipment damage or decreased performance, but not personal injury.

Special symbols

Some hazard categories have specific symbols, as shown in the following table.

Electrical hazard	Magnetic fields hazard
Electrical Hazard:	CAUTION:



Hot surface hazard

Hot surface hazards are indicated by a specific symbol that replaces the typical hazard level symbols:



CAUTION:

Description of user and installer symbols

	Specific information for personnel in charge of installing the product in the system (plumbing and/or electrical aspects) or in charge of maintenance.
	Specific information for users of the product.

Instructions

The instructions and warnings that are provided in this manual concern the standard version, as described in the sales document. Special version pumps may be supplied with supplementary instruction leaflets. Refer to sales contract for any modifications or special version characteristics. For instructions, situations, or events that is not considered in this manual or the sales document, contact the nearest Service Center.

1.3 Disposal of packaging and product

Observe the local regulations and codes in force regarding sorted waste disposal.

1.4 Warranty

For information about warranty, see the sales contract.

1.5 Spare parts



WARNING:

Only use original spare parts to replace any worn or faulty components. The use of unsuitable spare parts may cause malfunctions, damage, and injuries as well as void the guarantee.



CAUTION:

Always specify the exact product type and part number when requesting technical information or spare parts from the Sales and Service Department.

For more information about the product's spare parts, visit sales network's website.

1.6 DECLARATIONS OF CONFORMITY

1.6.1 EC Declaration of Conformity (Original)



Xylem Service Italia S.r.l., with headquarters in Via Vittorio Lombardi 14 - 36075 Montecchio Maggiore VI - Italy, hereby declares that the product:

Electric pump unit (see label on first page)

fulfills the relevant provisions of the following European directives:

- Machinery 2006/42/EC (ANNEX II - natural or legal person authorised to compile the technical file: Xylem Service Italia S.r.l.)
- Eco-design 2009/125/EC, Regulation (EC) No 640/2009 & Regulation (EU) No 4/2014 (Motor 3 ~, 50 Hz, PN $\geq 0,75$ kW) if IE2 or IE3 marked, Regulation (EU) No 547/2012 (Water pump) if MEI marked

and the following technical standards

- EN ISO 12100:2010, EN 809:1998+A1:2009, EN 60204-1:2006+A1:2009
- EN 60034-30:2009, EN 60034-30-1:2014

Montecchio Maggiore, 11.03.2016

Amedeo Valente
(Director of Engineering and R&D)

rev.01

1.6.2 EU Declaration of Conformity (No EMCD02)

1. Apparatus model/Product:
see label on first page
 2. Name and address of the manufacturer:
Xylem Service Italia S.r.l.
Via Vittorio Lombardi 14
36075 Montecchio Maggiore VI
Italy
 3. This declaration of conformity is issued under the sole responsibility of the manufacturer.
 4. Object of the declaration:
electric pump
 5. The object of the declaration described above is in conformity with the relevant Union harmonisation legislation:
Directive 2014/30/EU of 26 February 2014 (electromagnetic compatibility)
 6. References to the relevant harmonised standards used or references to the other technical specifications, in relation to which conformity is declared:
 7. Notified body: -
 8. Additional information: -
- Signed for and on behalf of:
Xylem Service Italia S.r.l.

Montecchio Maggiore, 11.03.2016

Amedeo Valente
(Director of Engineering and R&D)

rev.01

Lowara is a trademark of Xylem Inc. or one of its subsidiaries.

1.6.3 EC Declaration of Conformity (Original)



Xylem Service Italia S.r.l., with headquarters in Via Vittorio Lombardi 14 - 36075 Montecchio Maggiore VI - Italy, hereby declares that the product:

Pump (see label on first page)

fulfills the relevant provisions of the following European directives:

- Machinery 2006/42/EC (ANNEX II - natural or legal person authorised to compile the technical file: Xylem Service Italia S.r.l.)
- Eco-design 2009/125/EC, Regulation (EC) No 547/2012 (Water pump) if MEI marked

and the following technical standards

- EN ISO 12100:2010, EN 809:1998+A1:2009, EN 60204-1:2006+A1:2009
- EN 60034-30:2009, EN 60034-30-1:2014

Montecchio Maggiore, 11.03.2016

Amedeo Valente

(Director of Engineering and R&D)

rev.01

Lowara is a trademark of Xylem Inc. or one of its subsidiaries.

2 Transportation and Storage

2.1 Inspect the delivery

1. Check the outside of the package for evident signs of damage.
2. Notify our distributor within eight days of the delivery date, if the product bears visible signs of damage.

Unpack the unit

1. Follow applicable step:
 - If the unit is packed in a carton, then remove the staples and open the carton.
 - If the unit is packed in a wooden crate, then open the cover while paying attention to the nails and straps.
2. Remove the securing screws or the straps from the wooden base.

2.1.1 Inspect the unit

1. Remove packing materials from the product. Dispose of all packing materials in accordance with local regulations.
2. Inspect the product to determine if any parts have been damaged or are missing.
3. If applicable, unfasten the product by removing any screws, bolts, or straps.

For your personal safety, be careful when you handle nails and straps.

4. Contact the local sales representative if there is any issue.

2.2 Transportation guidelines

Precautions



WARNING:

- Observe accident prevention regulations in force.
- Crush hazard. The unit and the components can be heavy. Use proper lifting methods and wear steel-toed shoes at all times.

Check the gross weight that is indicated on the package in order to select proper lifting equipment.

Position and fastening

The pump or pump unit can be transported only horizontally. Make sure that the pump or pump unit is securely fastened during transportation and cannot roll or fall over.



WARNING:

Do not use eyebolts screwed on the motor for handling the whole electric pump unit.

Do not use the shaft end of the pump or of the motor to handle the pump, the motor or the unit.

- Eyebolts screwed onto the motor may be exclusively used to handle the individual motor or, in case of a not balanced distribution of weights, to partially lift the unit vertically starting from a horizontal displacement.

Pump unit must always be fixed and transported as shown in [Figure 5](#) on page 370, and the pump without motor must be fixed and transported as shown in [Figure 6](#) on page 370, [Figure 7](#) on page 370, and [Figure 8](#) on page 370.

Unit without motor



WARNING:

According to Machinery directive 2006/42/EC, a pump and motor that are purchased separately and then coupled together result in a new machine. The person making the coupling is responsible for all safety aspects of the combined unit and for CE-marking.

2.3 Storage guidelines

Storage location

The product must be stored in a covered and dry location free from heat, dirt, and vibrations.

NOTICE:

Protect the product against humidity, heat sources, and mechanical damage.

NOTICE:

Do not place heavy weights on the packed product.

2.3.1 Long-term storage

If the unit is stored for more than 6 months, these requirements apply:

- Store in a covered and dry location.
- Store the unit free from heat, dirt, and vibrations.
- Rotate the shaft by hand several times at least every three months.

Refer to the drive unit and coupling manufacturers for their long-term storage procedures.

For questions about possible long-term storage treatment services, please contact your local sales and service representative.

Ambient temperature

The product must be stored at an ambient temperature from -5°C to +40°C (23°F to 104°F).

3 Product Description



3.1 Pump design

The pump is a horizontal pump with volute casing close-coupled to standard electric motors.

The pump can be used for handling:

- Cold or warm water
- Clean liquids
- Liquids which are not chemically and mechanically aggressive to the pump materials.
- Liquids which are moderately aggressive to the pump materials.

The product can be supplied as a pump unit (pump and electric motor) or only as a pump.

NOTICE:

If you have purchased a pump without motor, make sure that the motor is suitable for coupling to the pump.

Intended use

The pump is suitable for:

- Water supply and water treatment
- Cooling and hot water supply in industries and building services
- Irrigation and sprinkler systems
- Heating systems
- Fire-fighting applications

Additional uses for optional material:

- District heating
- General industry

Improper use



WARNING:

Improper use of the pump may create dangerous conditions and cause personal injury and damage to property.

An improper use of the product leads to the loss of the warranty.

Examples of improper use:

- Liquids not compatible with the pump construction materials
- Hazardous liquids (such as toxic, explosive, flammable, or corrosive liquids)
- Potable liquids other than water (for example, wine or milk)

Examples of improper installation:

- Hazardous locations (such as explosive, or corrosive atmospheres).
- Location where the air temperature is very high or there is poor ventilation.
- Outdoor installations where there is no protection against rain or freezing temperatures.



DANGER:

Do not use this pump to handle flammable and/or explosive liquids.

NOTICE:

- Do not use this pump to handle liquids containing abrasive, solid, or fibrous substances.
- Do not use the pump for flow rates beyond the specified flow rates on the data plate.

Special applications

Contact the local sales and service representative in the following cases:

- If the density and/or viscosity value of the pumped liquid exceeds the value of water, such as water with glycol; as it may require a more powerful motor.
- If the pumped liquid is chemically treated (for example softened, deionized, demineralized etc.).
- Any situation that is different from the ones that is described and relate to the nature of the liquid.

3.2 Pump denomination

See [Figure 2](#) on page 354 for an explanation of the denomination code for the pump and one example.

3.3 Nameplate

The nameplate is located on the bearing bracket. The name plate lists key product specifications. For more information, see [Figure 1](#) on page 348.

The nameplate provides information regarding the impeller and casing material, the mechanical seal and their materials. For more information, see [Figure 3](#) on page 366.

IMQ or other marks (for electric pump only)

Unless otherwise specified, for products with a mark of electrical-related safety approval, the approval refers exclusively to the electrical pump.

3.4 Pump description

- Connection dimensions according EN 733 (models 32-125...-200; 40-125...-250; 50-125...-250; 65-160...-250; 80-160...-250).
- Volute casing pump with back pull out bearing bracket.

3.5 Material

The metallic parts of the pump that come in contact with liquid are made of the following:

Material code	Material casing / impeller	Standard/ Optional
SS	Stainless steel / Stainless steel	Standard
SN	Stainless steel / Stainless steel	Standard

3.6 Mechanical seal

Unbalanced single mechanical seal acc. EN 12756, version K.

3.7 Application limits

Maximum working pressure

Figure 4 on page 369 shows the maximum working pressure depending on the pump model and the temperature of the pumped liquid.

$$P_{1max} + P_{max} \leq PN$$

P_{1max} Maximum inlet pressure

P_{max} Maximum pressure generated by the pump

PN Maximum operating pressure

Liquid temperature intervals

For the working temperature range, see Figure 4 on page 369.

For special requirements, contact the sales and service representative.

Maximum number of starts per hour

kW	0.25	4.00	11	18.5	30	45	90
	-	-	-	-	-	-	-
	3.00	7.50	15	22	37	75	160
Starts per hour	60	40	30	24	16	8	4

Noise level

For the sound pressure levels of pump equipped with standard supplied motor, see Table 9 on page 370

For sound pressure levels of pump without motor, see Table 10 on page 372

4 Installation



Precautions



WARNING:

- Observe accident prevention regulations in force.
- Use suitable equipment and protection.
- Always refer to the local and/or national regulations, legislation, and codes in force regarding the selection of the installation site, plumbing, and power connections.



Electrical Hazard:

- Make sure that all connections are performed by qualified installation technicians and in compliance with the regulations in force.
- Before starting work on the unit, make sure that the unit and the control panel are isolated from the power supply and cannot be energized. This applies to the control circuit as well.

Grounding (earthing)



Electrical Hazard:

- Always connect the external protection conductor to ground (earth) terminal before making other electrical connections.
- You must ground (earth) all electrical equipment. This applies to the pump equipment, the driver, and any monitoring equipment. Test the ground (earth) lead to verify that it is connected correctly.
- If the motor cable is jerked loose by mistake, the ground (earth) conductor should be the last conductor to come loose from its terminal. Make sure that the ground (earth) conductor is longer than the phase conductors. This applies to both ends of the motor cable.
- Add additional protection against lethal shock. Install a high-sensitivity differential switch (30 mA) [residual current device RCD].

4.1 Facility requirements

4.1.1 Pump location



DANGER:

Do not use this unit in environments that may contain flammable/explosive or chemically aggressive gases or powders.

Guidelines

Observe the following guidelines regarding the location of the product:

- Make sure that no obstructions hinder the normal flow of the cooling air that is delivered by the motor fan.
- Make sure that the installation area is protected from any fluid leaks, or flooding.
- If possible, place the pump slightly higher than the floor level.
- The ambient temperature must be between 0°C (+32°F) and +40°C (+104°F).
- The relative humidity of the ambient air must be less than 50% at +40°C (+104°F).
- Contact the Sales and Service Department if:
 - The relative air humidity conditions exceed the guidelines.
 - The room temperature exceeds +40°C (+104°F).
 - The unit is located more than 1000 m (3000 ft) above the sea level. The motor performance may need to be de-rated or replaced with a more powerful motor.

For information about which value to de-rate the motor with, see Table 11 on page 374.

Pump positions and clearance

Provide adequate light and clearance around the pump. Make sure that it is easily accessible for installation and maintenance operations.

Installation above liquid source (suction lift)

The theoretical maximum suction height of any pump is 10.33m. In practice, the following affect the suction capacity of the pump:

- Temperature of the liquid
- Elevation above the sea level (in an open system)
- System pressure (in a closed system)
- Resistance of the pipes
- Own intrinsic flow resistance of the pump
- Height differences

The following equation is used to calculate the maximum height above the liquid level which the pump can be installed:

$$(p_b \cdot 10.2 - Z) \geq \text{NPSH} + H_f + H_v + 0.5$$

p_b Barometric pressure in bar (in closed system is system pressure)

NPSH Value in meter of the pump intrinsic flow resistance

H_f Total losses in meters caused by passage of liquid in the suction pipe of the pump

H_v Steam pressure in meters that correspond to the temperature of the liquid T °C

0.5 Recommended safety margin (m)

Z Maximum height at which the pump can be installed (m)

$(p_b \cdot 10.2 - Z)$ must always be a positive number.

For more information, see [Figure 12](#) on page 375.

NOTICE:

Do not exceed the pumps suction capacity as this could cause cavitation and damage the pump.

4.1.2 Piping requirements

Precautions



WARNING:

- Use pipes suited to the maximum working pressure of the pump. Failure to do so can cause the system to rupture, with the risk of injury.
 - Make sure that all connections are performed by qualified installation technicians and in compliance with the regulations in force.
-

NOTICE:

Observe all regulations issued by authorities having jurisdiction and by companies managing the public water supplies if the pump is connected to a public water system. If required, install appropriate back-flow-prevention device on the suction side.

Piping checklist

Check that the following requirements are met:

- All piping is independently supported, piping must not place a burden on the unit.
- Flexible pipes or unions are used, in order to avoid transmission of pump vibrations to the pipes and vice versa.
- Use wide bends, avoid using elbows which cause excessive flow resistance.
- The suction piping is perfectly sealed and air-tight.
- If the pump is used in an open circuit, then the diameter of the suction pipe is suited to the installation conditions. The suction pipe must not be smaller than the diameter of the suction port.

- If the suction piping must be larger than the suction side of the pump, then an eccentric pipe reducer is installed.
- If the pump is placed above liquid level, a foot valve is installed at the end of the suction piping.
- The foot valve is fully immersed into the liquid so that air cannot enter through the suction vortex, when the liquid is at the minimum level and the pump is installed above the liquid source.
- Appropriately sized on-off valves are installed on the suction piping and on the delivery piping (downstream to the check valve) for regulation of the pump capacity, for pump inspection, and for maintenance.
- Appropriately sized on-off valve is installed on the delivery piping (downstream to the check valve) for regulation of the pump capacity, for pump inspection, and for maintenance.
- In order to prevent back flow into the pump when pump is turned off a check valve is installed on the delivery piping.



WARNING:

Do not use the on-off valve on the discharge side in the closed position in order to throttle the pump for more than a few seconds. If the pump must operate with the discharge side closed for more than a few seconds, a bypass circuit must be installed to prevent overheating of the liquid inside the pump.

For illustrations that show the piping requirements, see [Figure 13](#) on page 376 and [Figure 14](#) on page 376.

4.2 Electrical requirements

- The local regulations in force overrule these specified requirements.
- In the case of fire fighting systems (hydrants and/or sprinklers), check the local regulations in force.

Electrical connection checklist

Check that the following requirements are met:

- The electrical leads are protected from high temperature, vibrations, and collisions.
- The power supply line is provided with:
 - A short-circuit protection device
 - A mains isolator switch with a contact gap of at least 3 mm

The electrical control panel checklist

NOTICE:

The control panel must match the ratings of the electric pump. Improper combinations could fail to guarantee the protection of the motor.

Check that the following requirements are met:

- The control panel must protect the motor against overload and short-circuit.
- Install the correct overload protection (thermal relay or motor protector).

Pump Type	Protection
Single phase standard electric pump ≤ 2.2 kW	<ul style="list-style-type: none"> – Built-in automatic reset thermal-ampereometric protection (motor protector) – Short circuit protection (must be supplied by the installer)³
Three phase electric pump ⁴	<ul style="list-style-type: none"> – Thermal protection (must be supplied by the installer) – Short circuit protection (must be supplied by the installer)

- The control panel must be equipped with a dry-running protection system to which a pressure switch, float switch, probes, or other suitable device is connected.
- The following devices are recommended for use on the suction side of the pump:
 - When the liquid is pumped from a water system, use a pressure switch.
 - When the liquid is pumped from a storage tank or reservoir, use a float switch or probes.
- When thermal relays are used, relays that are sensitive to phase failure are recommended.

The motor checklist



WARNING:

- Read the operating instructions in order to ensure whether a protection device is provided if another motor other than the standard is used.
- If the motor is equipped with automatic thermal protectors, be aware of the risk of unexpected starts in connection to overload. Do not use such motors for fire-fighting applications.

NOTICE:

- Only use dynamically balanced motors with a half-sized key in the shaft extension (IEC 60034-14) and with normal vibration rate (N).
- The mains voltage and frequency must agree with the specifications on the data plate.

In general, motors can operate under the following mains voltage tolerances:

Frequency Hz	Phase ~	UN [V] \pm %
50	1	220 – 240 \pm 6
	3	230/400 \pm 10
		400/690 \pm 10
60	1	220 – 230 \pm 6
	3	220/380 \pm 5
		380/660 \pm 10

³ fuses aM (motor starting), or magneto-thermal switch with curve C and Icn $\geq 4,5$ kA or other equivalent device.

⁴ Overload thermal relay with trip class 10A + fuses aM (motor starting) or motor protection magneto-thermal switch with starting class 10A.

Use cable according to rules with 3 leads (2+earth/ground) for single phase versions and with 4 leads (3+earth/ground) for three phase version.

4.3 Install the pump



4.3.1 Mechanical installation

Check the following before installation:

- Use a concrete of compressive strength class C12/15 which meets the requirements of exposure class XC1 to EN 206-1.
- The mounting surface must have set and must be completely horizontal and even.
- Observe the weights indicated.

Install the pump set

For examples of horizontal installations, see *Figure 15* on page 378

Check that the foundation has been prepared in accordance with the dimensions given in the outline drawing/general arrangement drawing.

For information about the pump base and anchor holes, see *Figure 16* on page 379.

1. Position the pump set on the foundation and level it with the help of a spirit level that is placed on the discharge port.
The permissible deviation is 0.2 mm/m.
2. Remove the plugs covering the ports.
3. Align the pump and piping flanges on both sides of the pump. Check the alignment of the bolts.
4. Fasten the piping with bolts to the pump. Do not force the piping into place.
5. Use shims for height compensation, if necessary.

Always fit shims, if any, immediately to the left and right of the foundation bolts between the baseplate/foundation. For a bolt-to-bolt distance (L) > 800 mm, fit extra shims halfway between the bolt holes.

6. Make sure that all shims lie perfectly flush.
7. Insert the foundation bolts into the holes provided.
8. Use concrete to set the foundation bolts into the foundation.
9. Wait until the concrete has set firmly, and then level the baseplate.
10. Tighten the foundation bolts evenly and firmly.

Note:

- For baseplates, it is recommended to grout the baseplate with low-shrinkage concrete.
- If the transmission of vibrations can be disturbing, provide vibration-damping supports between the pump and the foundation.

Mount the pump to a base frame

Be sure to check that the following are adhered to:

- Solid base frame which does not twist or vibrate during operation (resonance).
 - Mounting surfaces of the pump feet and the motor on the base frame must be flat (machining is recommended).
 - Safe fastening of pump and motor must be guaranteed.
 - Adequate space between pump and motor shaft must be left depending on the used coupling.
 - Between pump and base frame must be an adequate shimming, so that in case of replacement the same height between bottom and centerline can be adjusted (recommended vertical adjustment 4-6 mm).
- The coupling is aligned correctly if the distance between the two coupling halves is the same at all points around the circumference.
 - The radial and axial deviation between the two coupling halves must not exceed the values set by the manufacturer, during standstill as well as at operating temperature and under inlet pressure.

5. Re-tighten screws of the support and pump foot without transmitting any stresses and strains.

Dial gauges can be used in the place of ruler and thickness gauge.

Contact the local sales and service representative for any requests or information.

NOTE: Check alignment of coupling again in operation warm condition and on system pressure if available and correct, if necessary. Be sure that the unit can be easily turned by hand.

NOTICE:

Improper alignment of the unit can lead to damages at coupling and unit.

Install the coupling guard



CAUTION:

Never operate the pump without the coupling guard correctly installed.

'Wire mesh' type

For information see [Figure 17](#) on page 381.

1. Open and place the guard (1) in a way that it envelops the bearing cover and the supporting/adjusting ring (6).
2. Press the supporting/adjusting ring (6) axially to the motor.
3. Screw the fixing devices (2).

4.3.4 Electrical installation

1. Remove the screws of the terminal box cover.
2. Connect and fasten the power cables according to the applicable wiring diagram.

For wiring diagrams, see [Figure 19](#) on page 384. The diagrams are also available on the back of the terminal box cover.

- a) Connect the ground (earth) lead.

Make sure that the ground (earth) lead is longer than the phase leads.

- b) Connect the phase leads.

3. Mount the terminal box cover.

NOTICE:

Tighten the cable glands carefully to ensure protection against cable slipping and humidity entering the terminal box.

4. If the motor is not equipped with automatic reset thermal protection, then adjust the overload protection according to the list below.

4.3.2 Piping checklist

Check that the following are adhered to:

- The suction lift line has been laid with a rising slope, at positive suction head line with a downward slope towards the pump.
- The nominal diameters of the pipelines are at least equal to the nominal diameters of the pump ports.
- The pipelines have been anchored in close proximity to the pump and connected without transmitting any stresses or strains.



CAUTION:

Welding beads, scale and other impurities in the piping damage the pump.

- Free the piping from any impurities.
- If necessary, install a filter.

4.3.3 Coupling alignment

After mounting to the foundation and the connection of the piping, the coupling must be adjusted again, even if the unit was delivered completely mounted on the frame.

Remove the coupling guard

'Wire mesh' type

For information see [Figure 17](#) on page 381.

1. Unscrew the fixing devices (2).
2. Open the lift guard (1).
 - Do not loosen screws, washers and nuts.

Alignment

For information see [Figure 18](#) on page 383.

1. Loosen screws of the support and pump foot.
2. Place the ruler (1) axially on both coupling halves.
3. Leave the ruler (1) in this position and turn the coupling by hand.
 - The coupling is aligned correctly if the distances 'a' and 'b' to the respective shafts are the same at all points around the circumference.
 - The radial and axial deviation between the two coupling halves must not exceed the values set by the manufacturer, during standstill as well as at operating temperature and under inlet pressure.
4. Check the distance between the two coupling halves around the circumference with a gauge (2).

- If the motor is used with full load, then set the value to the nominal current value of electric pump (data plate)
- If the motor is used with partial load, then set the value to the operating current (for example measured with a current pincer).
- If the pump has a star-delta starting system, then adjust the thermal relay to 58% of the nominal current or operating current (only for three-phase motors).

5 Commissioning, Startup, Operation, and Shutdown



Precautions



WARNING:

- Make sure that the drained liquid does not cause damage or injuries.
- The motor protectors can cause the motor to restart unexpectedly. This could result in serious injury.
- Never operate the pump without the coupling guard correctly installed.



CAUTION:

- The outer surfaces of the pump and motor can exceed 40°C (104°F) during operation. Do not touch with any part of the body without protective gear.
- Do not put any combustible material near the pump.

NOTICE:

- Never operate the pump below the minimum rated flow, when dry, or without prime.
- Never operate the pump with the delivery ON-OFF valve closed for longer than a few seconds.
- Never operate the pump with the suction ON-OFF valve closed.
- Do not expose an idle pump to freezing conditions. Drain all liquid that is inside the pump. Failure to do so can cause liquid to freeze and damage the pump.
- The sum of the pressure on the suction side (mains, gravity tank) and the maximum pressure that is delivered by the pump must not exceed the maximum working pressure that is allowed (nominal pressure PN) for the pump.
- Do not use the pump if cavitation occurs. Cavitation can damage the internal components.

5.1 Fill the pump

For information about additional pump connections, see [Figure 20](#) on page 384.

Installations with liquid level above the pump (suction head)

For an illustration that shows where pump plugs are, see [Figure 21](#) on page 385.

1. Close the on-off valve located downstream from the pump.
2. Remove the fill (3) or gauge plug (1) and open the on/off valve upstream until the water flows out of the hole.

- a) Close the fill (3) or gauge plug (1).

Installations with liquid level below the pump (suction lift)

For an illustration that shows where pump plugs are, see .

1. All pipe system empty:
 - a) Open the on-off valve located upstream from the pump.
 - b) Remove the fill plug (3) and the gauge plug (1). Use a funnel to fill the pump through the fill hole until the water flows out of this hole.
 - c) Tighten the fill plug (3) and the gauge plug (1).
2. Filled discharge pipe system:
 - a) Open the on-off valve located upstream from the pump and open the on-off valve downstream.
 - b) Remove the gauge plug (1) until water flows out of this hole.
 - c) Tighten the gauge plug (1).

5.2 Check the rotation direction (three-phase motor)

Follow this procedure before start-up.

1. Locate the arrows on the adaptor or the motor fan cover to determine the correct rotation direction.
2. Start the motor.
3. Quickly check the direction of rotation through the coupling guard or through the motor fan cover.
4. Stop the motor.
5. If the rotation direction is incorrect, then do as follows:
 - a) Disconnect the power supply.
 - b) In the terminal board of the motor or in the electric control panel, exchange the position of two of the three wires of the supply cable.
For the wiring diagrams, see [Figure 19](#) on page 384.
 - c) Check the direction of rotation again.

5.3 Start the pump

The responsibility for checking the correct flow and the temperature of the pumped liquid rests with the installer or owner.

Before starting the pump, make sure that:

- The pump is correctly connected to the power supply.
- The pump is correctly filled according to instructions in *Fill the pump* (chapter 5).
- The on-off valve located downstream from the pump is closed.

1. Start the motor.
2. Gradually open the on-off valve on the discharge side of the pump.

At the expected operating conditions, the pump must run smoothly and quietly. If not, refer to [Troubleshooting](#) on page 23.

6 Maintenance



Precautions



Electrical Hazard:

Disconnect and lock out electrical power before installing or servicing the unit.



WARNING:

- Maintenance and service must be performed by skilled and qualified personnel only.
- Observe accident prevention regulations in force.
- Use suitable equipment and protection.
- Make sure that the drained liquid does not cause damage or injuries.

6.1 Service

If the user wishes to schedule regular maintenance deadlines, they are dependent on the type of pumped liquid and on the operating conditions of the pump.

Contact the local sales and service representative for any requests or information regarding routine maintenance or service.

Extraordinary maintenance may be necessary to clean the liquid end and/or replace worn parts.

Pumps with greased for life bearings

Pumps with greased for life bearings do not require any scheduled routine maintenance.

Pumps with re-greaseable bearings

- Regrease at 4000 operating hours, but at least once per year. Clean lubrication nipples (SN) first.
- Use NLGI Grade 2 grease or equivalent.

Contact the local sales and service representative for any requests or information.

Motor bearings

After approximately five years, the grease in the motor bearings is so aged that a replacement of the bearings is recommended. The bearings must be replaced after 25000 operating hours or according to the motor supplier maintenance instructions, whichever is shorter.

Motor with regreaseable bearings

Follow motor supplier maintenance instructions.

Coupling

Check the clearance in the coupling elements regularly, at least once a year. We recommend checking every 1000 operating hours or every three months, whichever comes first.

6.2 Inspection checklist

Check the coupling	Check the flexible elements of the coupling. Replace the relevant parts if there is any sign of wear and check the alignment.
Check the mechanical seal	Check for leakage of the mechanical seal. Re-

	place the mechanical seal if leakage is found.
Checking the bearing seals	Check correct seating of axial seal rings mounted on the shaft. Only gentle contact of the sealing lip shall be established.
Check for quiet running	Check frequently for quiet running of the pump with vibration measurements tools.

6.3 Disassemble and replace the pump parts

For more information about spare parts and assembly and disassembly of the pump, contact the local sales and service representative.

7 Troubleshooting



7.1 Troubleshooting for users

The main switch is on, but the electric pump does not start.

Cause	Remedy
The thermal protector incorporated in the pump (if any) has tripped.	Wait until the pump has cooled down. The thermal protector will automatically reset.
The protective device against dry running has tripped.	Check the liquid level in the tank, or the mains pressure.

The electric pump starts, but the thermal protection trips a varying time after.

Cause	Remedy
There are foreign objects (solids or fibrous substances) inside the pump which have jammed the impeller.	Contact the Sales and Service Department.
The pump is overloaded because it is pumping liquid that is too dense and viscous.	Check the actual power requirements based on the characteristics of the pumped liquid and then contact the Sales and Service Department.

The pump runs but delivers too little or no liquid.

Cause	Remedy
The pump is clogged.	Contact the Sales and Service Department.

The troubleshooting instructions in the tables below are for installers only.

7.2 The main switch is on, but the electric pump does not start



Cause	Remedy
There is no power supply.	<ul style="list-style-type: none"> Restore the power supply. Make sure all electrical connections to the power supply are intact.
The thermal protector incorporated in the pump (if any) has tripped.	Wait until the pump has cooled down. The thermal protector will automatically reset.
The thermal relay or motor protector in the electric control panel has tripped.	Reset the thermal protection.
The protective device against dry running has tripped.	Check the: <ul style="list-style-type: none"> liquid level in the tank, or the mains pressure. protective device and its connecting cables.
The fuses for the pump or auxiliary circuits are blown.	Replace the fuses.

7.3 The electric pump starts, but the thermal protector trips or the fuses blow immediately after 

Cause	Remedy
The power supply cable is damaged.	Check the cable and replace as necessary.
The thermal protection or fuses are not suited for the motor current.	Check the components and replace as necessary.
The electric motor is short circuit.	Check the components and replace as necessary.
The motor overloads.	Check the operating conditions of the pump and reset the protection.

7.4 The electric pump starts, but the thermal protector trips or the fuses blow a short time after 

Cause	Remedy
The electrical panel is situated in an excessively heated area or is exposed to direct sunlight.	Protect the electrical panel from heat source and direct sunlight.
The power supply voltage is not within the working limits of the motor.	Check the operating conditions of the motor.
A power phase is missing.	Check the <ul style="list-style-type: none"> power supply electrical connection

7.5 The electric pump starts, but the thermal protector trips a varying time after 

Cause	Remedy
There are foreign objects (solids or fibrous substances) inside the pump which have jammed the impeller.	Contact the local sales and service representative.
The pumps delivery rate is higher than the limits specified on the data plate.	Partially close the on-off valve down stream until the delivery rate is equal or less than the limits specified on the data plate.
The pump is overloaded because it is pumping liquid that is too dense and viscous.	Check the actual power requirements based on the characteristics of the pumped liquid and replace the motor accordingly.
The motor bearings are worn.	Contact the local sales and service representative.

7.6 The electric pump starts, but the system's general protection is activated 

Cause	Remedy
A short circuit in the electrical system.	Check the electrical system.

7.7 The electric pump starts, but the system's residual current device (RCD) is activated 

Cause	Remedy
There is an ground (earth) leakage.	Check the insulation of the electrical system components.

7.8 The pump runs but delivers too little or no liquid 

Cause	Remedy
There is air inside the pump or the piping.	<ul style="list-style-type: none"> Bleed the air
The pump is not correctly primed.	Stop the pump and repeat the prime procedure. If the problem continues: <ul style="list-style-type: none"> Check that the mechanical seal is not leaking. Check the suction pipe for perfect tightness. Replace any valves that are leaking.
The throttling on the delivery side is too extensive.	Open the valve.

Cause	Remedy
Valves are locked in closed or partially closed position.	Disassemble and clean the valves.
The pump is clogged.	Contact the local sales and service representative.
The piping is clogged.	Check and clean the pipes.
The rotation direction of the impeller is wrong .	Change the position of two of the phases on the terminal board of the motor or in the electric control panel.
The suction lift is too high or the flow resistance in the suction pipes is too great.	Check the operating conditions of the pump. If necessary, do the following: <ul style="list-style-type: none"> Decrease the suction lift Increase the diameter of the suction pipe.

7.9 The electric pump stops, and then rotates in the wrong direction

Cause	Remedy
There is a leakage in one or both of the following components: <ul style="list-style-type: none"> The suction pipe The foot valve or the check valve 	Repair or replace the faulty component.
There is air in the suction pipe.	Bleed the air.

7.10 The pump starts up too frequently

Cause	Remedy
There is a leakage in one or both of the following components: <ul style="list-style-type: none"> The suction pipe The foot valve or the check valve 	Repair or replace the faulty component.

Cause	Remedy
There is a ruptured membrane or no air pre-charge in the pressure tank.	See the relevant instructions in the pressure tank manual.

7.11 The pump vibrates and generates too much noise

Cause	Remedy
Pump cavitation	Reduce the required flow rate by partially closing the on-off valve downstream from the pump. If the problem persists check the operating conditions of the pump (for example height difference, flow resistance, liquid temperature).
The motor bearings are worn.	Contact the local sales and service representative.
There are foreign objects inside the pump.	Contact the local sales and service representative.
Impeller rubs on the wear ring	Contact the local sales and service representative.
Coupling misaligned	Check the coupling alignment.
Flexible elements of the coupling worn	Check and replace the relevant parts if there is any sign of wear.

For any other situation, refer to the local sales and service representative.

1 Introduction et sécurité

1.1 Introduction

Objet de ce manuel

L'objet de ce manuel est d'apporter les informations nécessaires pour :

- Installation
- Utilisation
- Entretien



ATTENTION :

Lire attentivement ce manuel avant d'installer et d'utiliser ce produit. Une mauvaise utilisation du produit peut entraîner

des blessures et des dégâts matériels et pourrait annuler la garantie.

REMARQUE :

Conserver ce manuel pour une consultation ultérieure et veiller à ce qu'il puisse facilement être consulté sur le site à tout moment.

1.1.1 Utilisateurs sans expérience



AVERTISSEMENT :

Ce produit est destiné à être utilisé par du personnel qualifié exclusivement.

Respecter les précautions ci-dessous :

العلاج	الأسباب
رفع الشفط مرتفع للغاية أو مقاومة الضخ في أنابيب الشفط كبيرة للغاية. • تقليل رفع الشفط • زيادة قطر أنبوب الشفط	تحقق من ظروف تشغيل المضخة. قم بما يلي عند الضرورة:



7.9 توقف المضخة الكهربائية عن العمل، ثم دورانها في الاتجاه الخاطئ

العلاج	الأسباب
يوجد تسرب في أحد المكونات التاليين أو كليهما: إصلاح أو استبدال • أنبوب الشفط • الصمام القضي أو صمام عدم الإرجاع	يوجد تسرب في أحد المكونات التاليين أو كليهما: إصلاح أو استبدال • أنبوب الشفط • الصمام القضي أو صمام عدم الإرجاع
وجود هواء في أنبوب الشفط.	تصفية الهواء.



7.10 بدء تشغيل المضخة بشكل متكرر للغاية

العلاج	الأسباب
يوجد تسرب في أحد المكونات التاليين أو كليهما: إصلاح أو استبدال • أنبوب الشفط • الصمام القضي أو صمام عدم الإرجاع	يوجد تسرب في أحد المكونات التاليين أو كليهما: إصلاح أو استبدال • أنبوب الشفط • الصمام القضي أو صمام عدم الإرجاع
يوجد غشاء متمزق أو عدم وجود شحن مسبق انظر التعليمات ذات الصلة في دليل خزان الضغط.	يوجد غشاء متمزق أو عدم وجود شحن مسبق انظر التعليمات ذات الصلة في دليل خزان الضغط.



7.11 المضخة تهتز وتصدر ضوضاء شديدة.

العلاج	الأسباب
تكون تجاويف بالمضخة قلل معدل الضخ المطلوب عن طريق الغلق الجزئي لصمام الفتح/الغلق القادم من المضخة. إذا استمرت المشكلة، تحقق من ظروف تشغيل المضخة (على سبيل المثال، اختلاف الارتفاع، مقاومة الضخ، درجة حرارة السائل).	تكون تجاويف بالمضخة قلل معدل الضخ المطلوب عن طريق الغلق الجزئي لصمام الفتح/الغلق القادم من المضخة. إذا استمرت المشكلة، تحقق من ظروف تشغيل المضخة (على سبيل المثال، اختلاف الارتفاع، مقاومة الضخ، درجة حرارة السائل).
محمّل الموتور بالية.	اتصل بممثل المبيعات والخدمة المحلي.
توجد أجسام غريبة داخل المضخة.	اتصل بممثل المبيعات والخدمة المحلي.
تحثك الدفاعة بحلقة التوجيه.	اتصل بممثل المبيعات والخدمة المحلي.
لم تتم محاذاة القارئة بشكل صحيح	قم بالتحقق من محاذاة القارئة.
العناصر المرنة في القارئة بالية	قم بالتحقق واستبدل القطع ذات الصلة إذا كانت هناك أي علامات بلي.

لأي موقف آخر، ارجع إلى ممثل المبيعات والخدمة المحلي.

العلاج	الأسباب
توجد أجسام غريبة (مواد صلبة أو ليفية) داخل المضخة والتي أدت بدورها إلى انحسار الدفاعة.	اتصل بممثل المبيعات والخدمة المحلي.
معدل التسليم الخاص بالمضخات أعلى من الحدود المبيّنة على لوح البيانات.	قم بغلق جزئي لصمام الفتح/الغلق القادم من المضخة حتى يصبح معدل التسليم مساوياً للحدود المبيّنة على لوح البيانات أو أقل منها.
تتعرض المضخة لحمل زائد نظراً لأنها تتضخ سائل كثيف ولزج للغاية.	تحقق من متطلبات الطاقة الفعلية بناءً على خصائص السائل المضخوخ واستبدل الموتور حسب ذلك.
محمّل الموتور بالية.	اتصل بممثل المبيعات والخدمة المحلي.



7.6 يبدأ تشغيل المضخة الكهربائية، ولكن يتم تنشيط الوقاية العامة للنظام

العلاج	الأسباب
حدث دائرة قصر في النظام الكهربائي.	افحص النظام الكهربائي.



7.7 يبدأ تشغيل المضخة الكهربائية، لكن يتم تنشيط الأداة التي تعمل بالتيار المتبقي (RCD)

العلاج	الأسباب
هناك تسرب أرضي.	تحقق من عزل مكونات النظام الكهربائي.





7.8 تعمل المضخة ولكنها تقوم بتوصيل القليل من السائل أو لا شيء على الإطلاق

العلاج	الأسباب
يوجد هواء داخل المضخة أو الأنايب.	• تصفية الهواء
لم يتم تحضير المضخة بشكل صحيح.	قم بإيقاف تشغيل المضخة وتكرار إجراءات التحضير.
إذا استمرت المشكلة:	تحقق من عدم وجود تسريب في مانع التسرب الميكانيكي. افحص أنبوب الشفط للتحقق من إحكام الربط. استبدل أي صمامات يوجد بها تسريب.
الخفق على جانب التوصيل مكثف للغاية.	افتح الصمام.
الصمامات تبتد في مقلق أو مقلق جزئياً.	قم بتفكيك الصمامات وتنظيفها.
انسداد المضخة.	اتصل بممثل المبيعات والخدمة المحلي.
انسداد الأنايب.	قم بفحص الأنايب وتنظيفها.
اتجاه دوران الدفاعة غير صحيح.	قم بتغيير الموضع لطورين من الأطوار على اللوحة الطرفية للموتور أو في لوحة التحكم الكهربائية.

Tehniline lisa • Tehniskais pielikums • Techninių duomenų priedas • Dodatek Dane techniczne • Technický dodatek • Technická príloha • Műszaki adatok függeléke • Anexă tehnică • Техническо приложение • Tehnična priloga • Tehnički dodatak • Tehnički dodatak • Τεχνικό παράρτημα • Teknik ek • Техническое приложение • Технічний додаток • الملحق الفني

1.



1		3		4		5		7		8		2		6	
 LOWARA 															
TYPE								No./Date							
PN				kPa				Code							
○ t max		°C		øF mm				○							
t min		°C		øT mm											
Q m ³ /h			H m			n 1/min			P ₂ kW			øF MEI±		øT ηp %	
-			-												
kg										REGULATION (EU) No 547/2012					
15		9		10		11		12		13		14			

ESH_M0030_A_sc



1	3	7	4	5	8	2	6	15
				No/Date REGULATION (EU) No 547/2012				
TYPE				Code				
PN	kPa	t max	°C	t min	°C	kg		
∅F mm	H m			∅T mm	n 1/min	P max kW	∅F MEI%	∅T ηp %
Q m ³ /h								
-	-	-	-	-	-	-	-	-
-	-	-	-	-	-	-	-	-
-	-	-	-	-	-	-	-	-
9	10	11	12	13	14			

ESH_M0031_A_sc

Italiano

1. Tipo di pompa
2. Numero di serie + data di fabbricazione
3. Pressione massima d'esercizio
4. Temperatura massima operativa del liquido
5. Temperatura minima operative del liquido
6. Codice pompa
7. Diametro intero della girante (solo per giranti non tornite)
8. Diametro ridotto della girante (solo per giranti tornite)
9. Campo della portata
10. Campo della prevalenza
11. Velocità
12. Potenza pompa nominale o massima (unità della pompa elettrica); potenza pompa massima assorbita (pompa)
13. Indice di efficienza minimo
14. Efficienza idraulica nel punto di efficienza migliore (solo per giranti tornite)
15. Peso

English

1. Pump type
2. Serial number + date of manufacture
3. Maximum operating pressure
4. Maximum operating liquid temperature
5. Minimum operating liquid temperature
6. Pump code
7. Full impeller diameter (only for full impellers)
8. Reduced impeller diameter (only for trimmed impellers)
9. Flow range
10. Head range
11. Speed
12. Nominal or maximum pump power (electric pump unit); maximum pump power absorbed (pump)
13. Minimum efficiency index
14. Hydraulic efficiency in best efficiency point (only for trimmed impellers)
15. Weight

Français

1. Type de pompe
2. Numéro de série + date de fabrication
3. Pression maximale de fonctionnement
4. Température maximale de liquide en fonctionnement
5. Température minimale de liquide en fonctionnement
6. Code de la pompe
7. Diamètre de roue complète (seulement pour les roues complètes)
8. Diamètre de roue réduit (seulement pour les roues rectifiées)
9. Gamme de débit
10. Plage de hauteur manométrique
11. Vitesse
12. Puissance nominale ou maximale de la pompe (unité de pompe électrique) ; puissance de pompe maximale absorbée (pompe)
13. Indice de rendement minimal
14. Rendement hydraulique au point de meilleur rendement (seulement pour les roues rectifiées)
15. Poids

- для регульованих робочих коліс)
9. Діапазон витрат
 10. Діапазон напору
 11. Швидкість
 12. Номінальна або максимальна потужність насосу (електрична насосна установка); максимальна споживана потужність насосу (насос)
 13. Мінімальний ККД
 14. Гідравлічний ККД в точці оптимального ККД (тільки для зменшених робочих коліс)
 15. Vara
- 2.

12. طاقة المضخة الاسمية أو القصوى (وحدة مضخة كهربائية)؛ طاقة المضخة القصوى الممتصة (المضخة)
13. مؤشر الحد الأدنى للكفاءة
14. الكفاءة الهيدروليكية عند نقطة أفضل كفاءة (للذفاعات المصغرة فقط)
15. الوزن

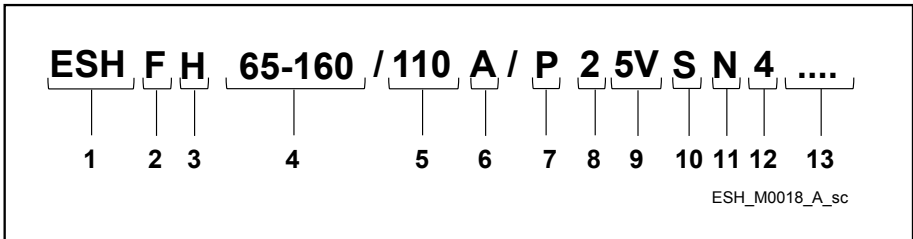

Italiano

1. ESH = Tipo pompa
2. Indicazione giunto; F = montato su telaio, C = telaio montato con giunto distanziale
3. Tipo di azionamento; niente = motore elettrico asincrono standard, H = dotato di Hydrovar, X = altro
4. 65-160 = Dimensione della pompa
5. 110 = Potenza nominale (kWx10)
6. Girante; vuoto = diametro intero, A = diametro tornito, B = diametro tornito, X = altro
7. Tipo di motore, P = PLM, S = SM, W = WEG, X = Altro
8. Numero di poli; 2 = a 2 poli, 4 = a 4 poli, 6 = a 6 poli
9. Tensione e frequenza elettrica;

50 Hz	
5H	1x220-240 V
5R	3x220-240/380-415 V
5V	3x380-415/660-690 V
5P	3x200-208/346-360 V
5S	3x255-265/440-460 V

English

1. ESH = Pump type
2. Coupling indication; F = frame-mounted, C = frame-mounted with spacer coupling
3. Driver type; void= standard asynchronous motor, H = equipped with Hydrovar, X =other drivers
4. 65-160 = Pump size
5. 110 = Rated motor power (kWx10)
6. Impeller; void = full diameter, A = trimmed diameter, B = trimmed diameter, X = other
7. Motor type, P = PLM, S = SM, W = WEG, X = Other
8. Number of poles; 2 = 2-pole, 4 = 4-pole, 6 = 6-pole
9. Electrical voltage and frequency;

50 Hz	
5H	1x220-240 V
5R	3x220-240/380-415 V
5V	3x380-415/660-690 V
5P	3x200-208/346-360 V
5S	3x255-265/440-460 V
5T	3x290-300/500-525 V

Français

1. ESH = Type de pompe
2. Indication d'accouplement ; F = monté sur le châssis, C = monté sur le châssis avec entretoise d'accouplement
3. Type de variateur ; vide = moteur à synchrone standard, H = équipé Hydrovar, X = autres variateurs
4. 65-160 = Dimension de pompe
5. 110 = Puissance nominale du moteur (kWx10)
6. Roue ; vide = diamètre complet, A = diamètre rectifié, B = diamètre rectifié, X = autre
7. Type de moteur, P = PLM, S = SM, W = WEG, X = Autre
8. Nombre de pôles ; 2 = 2 pôles, 4 = 4 pôles, 6 = 6 pôles
9. Tension et fréquence électrique ;

50 Hz	
5H	1x220-240 V
5R	3x220-240/380-415 V
5V	3x380-415/660-690 V
5P	3x200-208/346-360 V
5S	3x255-265/440-460 V

50 Hz	
5T	3x290-300/500-525 V
5W	3x440-460/- V

60 Hz	
6F	1x220-230 V
6E	1x200-210 V
6P	3x220-230/380-400 V
6R	3x255-277/440-480 V
6V	3x440-480/- V
6U	3x380-400/660-690 V
6N	3x200-208/346-360 V
6T	3x330-346/575-600 V

10. Materiale corpo pompa
11. Materiale girante
12. Tenuta meccanica + configurazione materiale O-ring
13. Cifre libere per le opzioni

Deutsch

1. ESH = Pumpentyp
2. Kupplungsangabe; F = Rahmenmontiert, C = Rahmenmontiert mit Kupplung mit Abstandshalter
3. Antriebstop; leer = standardmäßiger Asynchronmotor, H = ausgestattet mit Hydrovar, X = sonstige Antriebe
4. 65–160 = Pumpengröße
5. 110 = Motornennleistung (kW x 10)
6. Laufgrad; leer = kompletter Durchmesser, A = gekürzter Durchmesser, B = gekürzter Durchmesser, X = Sonstige
7. Motortyp, P = PLM, S = SM, W = WEG, X = Sonstige
8. Anzahl der Pole; 2 = 2-poliger, 4 = 4-poliger, 6 = 6-poliger
9. Elektrische Spannung und Frequenz;

50 Hz	
5H	1x220-240 V
5R	3x220-240/380-415 V
5V	3x380-415/660-690 V
5P	3x200-208/346-360 V
5S	3x255-265/440-460 V
5T	3x290-300/500-525 V
5W	3x440-460/- V

60 Hz	
6F	1x220-230 V

50 Hz	
5W	3x440-460/- V

60 Hz	
6F	1x220-230 V
6E	1x200-210 V
6P	3x220-230/380-400 V
6R	3x255-277/440-480 V
6V	3x440-480/- V
6U	3x380-400/660-690 V
6N	3x200-208/346-360 V
6T	3x330-346/575-600 V

10. Casing material
11. Impeller material
12. Mechanical seal + O-ring material configuration
13. Free digits for options

Español

1. ESH = tipo de bomba
2. Indicación de acoplamiento; F = montado en bastidor, C = montado en bastidor con acoplamiento con espaciador
3. Tipo de motor; nulo = motor asincrono estándar, H = equipado con Hydrovar, X = otros motores
4. 65–160 = tamaño de la bomba
5. 110 = Potencia nominal del motor (kWx10)
6. Impulsor; vacío = diámetro completo, A = diámetro activado, B = diámetro activado, X = otros
7. Tipo de motor, P = PLM, S = SM, W = WEG, X = otros
8. Número de polos; 2 = 2 polos, 4 = 4 polos, 6 = 6 polos
9. Frecuencia y tensión eléctrica;

50 Hz	
5H	1x220-240 V
5R	3x220-240/380-415 V
5V	3x380-415/660-690 V
5P	3x200-208/346-360 V
5S	3x255-265/440-460 V
5T	3x290-300/500-525 V
5W	3x440-460/- V

50 Hz	
5T	3x290-300/500-525 V
5W	3x440-460/- V

60 Hz	
6F	1x220-230 V
6E	1x200-210 V
6P	3x220-230/380-400 V
6R	3x255-277/440-480 V
6V	3x440-480/- V
6U	3x380-400/660-690 V
6N	3x200-208/346-360 V
6T	3x330-346/575-600 V

10. Matériau du corps
11. Matériau de la roue
12. Configuration de joint mécanique et matériau de joint torique
13. Chiffres libres pour options

Português

1. ESH = tipo de bomba
2. Indicação do acoplamento; F = montado na estrutura, C = montado na estrutura com acoplamento espaçador
3. Tipo de accionamento; nulo = motor assíncrono padrão, H = equipado com Hydrovar, X = outros accionadores
4. 65–160 = Dimensão da bomba
5. 110 = Alimentação nominal do motor (kW x 10)
6. Impulsor; nulo = diâmetro integral, A = diâmetro aparado, B = diâmetro aparado, X = outro
7. Tipo de motor, P = PLM, S = SM, W = WEG, X = Outro
8. Número do pólos; 2 = de 2 pólos, 4 = de 4 pólos, 6 = de 6 pólos
9. Frequência e voltagem eléctrica;

50 Hz	
5H	1x220-240 V
5R	3x220-240/380-415 V
5V	3x380-415/660-690 V
5P	3x200-208/346-360 V
5S	3x255-265/440-460 V
5T	3x290-300/500-525 V
5W	3x440-460/- V

7. Тип двигуна, P = PLM, S = SM, W = WEG, X = інший
 8. Кількість полюсів; 2 = 2-полярний, 4 = 4-полярний, 6 = 6-полярний
 9. Напряга і частота електричного струму

50 Hz	
5H	1x220-240 V
5R	3x220-240/380-415 V
5V	3x380-415/660-690 V
5P	3x200-208/346-360 V
5S	3x255-265/440-460 V
5T	3x290-300/500-525 V
5W	3x440-460/- V

60 Hz	
6F	1x220-230 V
6E	1x200-210 V
6P	3x220-230/380-400 V
6R	3x255-277/440-480 V
6V	3x440-480/- V
6U	3x380-400/660-690 V
6N	3x200-208/346-360 V
6T	3x330-346/575-600 V

Hz 50	
1x220-240 V	5H
3x220-240/380-415 V	5R
3x380-415/660-690 V	5V
3x200-208/346-360 V	5P
3x255-265/440-460 V	5S
3x290-300/500-525 V	5T
3x440-460/- V	5W

Hz 60	
1x220-230 V	6F
1x200-210 V	6E
3x220-230/380-400 V	6P
3x255-277/440-480 V	6R
3x440-480/- V	6V
3x380-400/660-690 V	6U
3x200-208/346-360 V	6N
3x330-346/575-600 V	6T

10. مواد العلية
 11. مواد وحدة الدفع
 12. مائع التسرب الميكانيكي + تكوين المواد بحلقة دائرية
 13. أرقام حرة للخيارات
10. Матеріал корпусу
 11. Матеріал робочого колеса
 12. Конфігурація матеріалів збірки механічне ущільнення + ущільнювальне кільце
 13. Вільні позиції для опцій

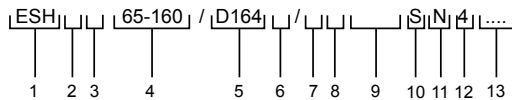

ESH_M0019_A_sc

Italiano

- ESH = Tipo pompa
- Indicazione giunto; vuoto = asse nudo
- Vuoto
- 65-160 = Dimensione della pompa
- D164 = Diametro della girante
- Vuoto
- Vuoto
- Vuoto
- Vuoto
- Vuoto
- Materiali corpo pompa
- Materiali girante

English

- ESH = Pump type
- Coupling indication; void = bare shaft
- Void
- 65-160 = Pump size
- D164 = Impeller diameter
- Void
- Void
- Void
- Void
- Void
- Casing material
- Impeller material

Français

- ESH = Type de pompe
- Indication d'accouplement ; vide = arbre nu
- Vide
- 65-160 = Dimension de pompe
- D164 = Diamètre de la roue
- Vide
- Vide
- Vide
- Vide
- Vide
- Matériau du corps
- Matériau de la roue

12. Tenuta meccanica + configurazione materiale O-ring
13. Cifre libere per le opzioni

12. Mechanical seal + O-ring material configuration
13. Free digits for options

12. Configuration de joint mécanique et matériau de joint torique
13. Chiffres libres pour options

Deutsch

1. ESH = Pumpentyp
2. Kupplungsangabe; Leer = nur mit Welle
3. Leer
4. 65–160 = Pumpengröße
5. D164 = Laufraddurchmesser
6. Leer
7. Leer
8. Leer
9. Leer
10. Gehäusewerkstoff
11. Laufradwerkstoff
12. Werkstoffkonfiguration für Gleitringdichtung + O-Ring
13. Freie Ziffern für Optionen

Español

1. ESH = tipo de bomba
2. Indicación de acoplamiento; nulo = eje libre
3. Nulo
4. 65–160 = tamaño de la bomba
5. D164 = diámetro del impulsor
6. Nulo
7. Nulo
8. Nulo
9. Nulo
10. Material de la carcasa
11. Material del impulsor
12. Configuración del material del sello mecánico y la junta tórica
13. Dígitos libres para opciones

Português

1. ESH = tipo de bomba
2. Indicação do acoplamento; inválido = eixo simples
3. Inválido
4. 65–160 = Dimensão da bomba
5. D164 = Diâmetro do impulsor
6. Inválido
7. Inválido
8. Inválido
9. Inválido
10. Material da caixa
11. Material do impulsor
12. Configuração do vedante mecânico + material do anel em O
13. Dígitos livres para opções

Nederlands

1. ESH = type pomp
2. Koppelingindicatie; hole = onbedekte as
3. Hol
4. 65–160 = pompgroote
5. D164 = Waaierdiameter
6. Hol
7. Hol
8. Hol
9. Hol
10. Materiaal van de behuizing
11. Materiaal van het rotorblad
12. Mechanische sluiting + O-ring materiaal configuratie
13. Vrije getallen voor opties

Dansk

1. ESH = Pumpetype
2. Koblingsindikation; ugyldig = fritliggende aksel
3. Ugyldig
4. 65–160 = Pumpestørrelse
5. D164 = Pumpehjul diameter
6. Ugyldig
7. Ugyldig
8. Ugyldig
9. Ugyldig
10. Kabinettets materiale
11. Pumpehjulets materiale
12. Mekanisk forpakning + O-ringsmaterialekonfiguration
13. Ledige cifre til indstillinger

Norsk

1. ESH = Pump type
2. Kopplingsindikasjon, void = bare aksel
3. Void
4. 65–160 = Pumpestørrelse
5. D164 = Pumpehjulsdiameter
6. Void
7. Void
8. Void
9. Void
10. Husmateriale
11. Pumpehjulsmaterialer
12. Konfigurasjon me mekanisk tetning + o-ringmateriale
13. Fire sifre for alternativer

Svenska

1. ESH = Pumptyp
2. Kopplingsindikering; blank = bar axel
3. Luftficka
4. 65–160 = Pumpstorlek
5. D164 = Pumphjulsdiameter
6. Luftficka
7. Luftficka
8. Luftficka
9. Luftficka
10. Pumfhusmaterial
11. Pumphjulsmaterial
12. Materialkonfiguration för mekanisk tätning och O-ring
13. Ledig siffror för tillval

Suomi

1. ESH = pumputyyppi
2. Kytkimen ilmaisin: tyhjä = paljas akseli
3. Tyhjio
4. 65–160 = pumpun koko
5. D164 = juoksupyörän halkaisija
6. Tyhjio
7. Tyhjio
8. Tyhjio
9. Tyhjio
10. Pesän materiaali
11. Juoksupyörän materiaali
12. Mekaanisen tiivisteen ja O-renkaan materiaalikonfiguraatio
13. Vapaat numerot vaihtoehtoja varten

Íslenska

1. ESH = Tegund dælu
2. Tengivísun; ógilt = ber leggur
3. Ógilt
4. 65–160 = Dælustærð
5. D164 = Ummál dæluhjólstillingar
6. Ógilt
7. Ógilt
8. Ógilt
9. Ógilt
10. Hlíffóarefni
11. Dæluhjólsefni
12. Pakkadós + stílling O-hringefnis
13. Lausir tölustafir fyrir valmöguleika

Eesti

1. ESH = pumba tüüp
2. Siduri tähis; tühi = ainult völli
3. Tühi
4. 65–160 = pumba suurus
5. D164 = rootori läbimõõt

Latviešu

1. ESH = sūkņa veids
2. Savienojuma norāde; tukšs = nepārsēgta vārpsta
3. Tukšs
4. 65–160 = sūkņa izmērs

Lietuvių k.

1. ESH – siurblio tipas
2. Movos indikacija; vakuumas – tik velenas
3. Vakuumas
4. 65–160 – siurblio dydis

6. Tühi
7. Tühi
8. Tühi
9. Tühi
10. Kesta materjal
11. Rootori materjal
12. Mehaaniline tihend + O-rõn-
ga materjali konfiguratsioon
13. Valikuteks vabad numbrid

5. D164 = darbrata diametrs
6. Tukšs
7. Tukšs
8. Tukšs
9. Tukšs
10. Apvalka materiāls
11. Darbrata materiāls
12. Mehāniskā blīvlēga + blīv-
gredzena materiāla konfigurācija
13. Cipari pēc izvēles

5. D164 – sparnuotēs sker-
smuo
6. Vakuumas
7. Vakuumas
8. Vakuumas
9. Vakuumas
10. Korpuso medžiaga
11. Sparnuotēs medžiaga
12. Mechaninio sandariklio ir
žiedinio sandariklio med-
žiagų deriniai
13. Kintantys skaitmenys, nuro-
dantys parinktis

polски

1. ESH = typ pompy
2. Oznaczenie sprężęgia; puste
miejsce = nagi wał
3. Puste miejsce
4. 65–160 = wielkość pompy
5. D164 = średnica wirnika
6. Puste miejsce
7. Puste miejsce
8. Puste miejsce
9. Puste miejsce
10. Materiał obudowy
11. Materiał wirnika
12. Uszczelka mechaniczna i
konfiguracja materiału pier-
ścienia O-ring
13. Dowlone cyfry dla opcji

magyar

1. ESH = a szivattyú típusa
2. Csatlakozásjelzés; üres =
üres tengely
3. Üres
4. 65–160 = a szivattyú mérete
5. D164 = A járókerék átmérője
6. Üres
7. Üres
8. Üres
9. Üres
10. Ház anyaga
11. Járókerék anyaga
12. Mechanikus tömítés + O-
gyűrű anyag elrendezés
13. Opciókhoz szabadon fel-
használható számjegyek

Slovenščina

1. ESH = vrsta črpalke
2. Oznaka spoja; nično = praz-
na gred
3. Nično
4. 65–160 = Velikost črpalke
5. D164 = premer rotorja
6. Nično
7. Nično
8. Nično
9. Nično
10. Material ohišja

Čeština

1. ESH = Typ čerpadla
2. Popis spojky; prázdný =
s holou hřídelí
3. Prázdný
4. 65–160 = Velikost čerpadla
5. D164 = Průměr oběžného
kola
6. Prázdný
7. Prázdný
8. Prázdný
9. Prázdný
10. Materiál skříně
11. Materiál oběžného kola
12. Konfigurace materiálu me-
chanické ucpávky + těsnící-
ho O-kroužku
13. Volné číslice pro volitelné
vybavení

Română

1. ESH = Tip pompă
2. Indicator de cuplare; spațiu
necompletat = ax de fixare
fără filet
3. Spațiu necompletat
4. 65-160 = Dimensiune pom-
pă
5. D164 = Diametru rotor cu
pale
6. Spațiu necompletat
7. Spațiu necompletat
8. Spațiu necompletat
9. Spațiu necompletat
10. Material carcasă
11. Material rotor cu pale
12. Configurație material garni-
tură de etanșare mecanică +
inel de etanșare
13. Cifre libere pentru opțiuni

Hrvatski

1. ESH = Vrsta pumpe
2. Indikacija spajanja; prazno =
gol osovina
3. Prazno
4. 65–160 = Veličina pumpe
5. D164 = Promjer rotora
6. Prazno
7. Prazno
8. Prazno
9. Prazno
10. Materijal kućišta

Slovenčina

1. ESH = typ čerpadla
2. Označenie spoja, prázdný =
holý hriadel'
3. Prázdný
4. 65 – 160 = rozmyry čerpadla
5. D164 = priemer obežného
kolesa
6. Prázdný
7. Prázdný
8. Prázdný
9. Prázdný
10. Materiál skrine
11. Materiál obežného kolesa
12. Konfigurácia materiálov me-
chanického tesnenia + O-
krúžka
13. Voľné voľiteľné číslice

Български

1. ESH = тип на помпата
2. Индикация на куплунга;
празно = гол вал
3. Празно
4. 65–160 = Размер на
помпата
5. D164 = Диаметър на
ротора
6. Празно
7. Празно
8. Празно
9. Празно
10. Материал на корпуса
11. Материал на работното
копело
12. Материал на
конфигурацията
механично уплътнение и
O-пръстен
13. Свободни числа за опции

Srpski

1. ESH = Tip pumpe
2. Indikacija spajanja; prazno =
gola osovina
3. Prazno
4. 65–160 = Veličina pumpe
5. D164 = Prečnik rotora
6. Prazno
7. Prazno
8. Prazno
9. Prazno
10. Materijal kućišta

11. Material rotorja
12. Konfiguracija materialov za mehansko tesnilo + O-tesnilo
13. Prosti znaki za možnosti

11. Materijal rotora
12. Konfiguracija materijala mehaničkog zatvarača + O-prstena
13. Slobodan unos za opcije

11. Materijal rotora
12. Konfiguracija materijala mehaničkog zatvarača + O-prstena
13. Slobodan unos cifara za opcije

Ελληνικά

1. ESH = Τύπος αντλίας
2. Ένδειξη σύζευξης, κενό = γυμνός άξονας
3. Κενό
4. 65–160 = Μέγεθος αντλίας
5. D164 = Διάμετρος φτερωτής
6. Κενό
7. Κενό
8. Κενό
9. Κενό
10. Υλικό κελύφους
11. Υλικό φτερωτής
12. Διαμόρφωση μηχανικής στεγανοποίησης + υλικού δακτυλίου κυκλικής διατομής
13. Ελεύθερα ψηφία για επιλογές

Türkçe

1. ESH = Pompa tipi
2. Kaplin gösterimi; geçersiz = çiplak mil
3. Geçersiz
4. 65–160 = Pompa boyutu
5. D164 = Çarkın çapı
6. Geçersiz
7. Geçersiz
8. Geçersiz
9. Geçersiz
10. Gövde malzemesi
11. Çark malzemesi
12. Mekanik mühür + O-halka malzeme yapılandırması
13. Seçenekler için serbest rakamlar

Русский

1. ESH = тип насоса
2. Обозначения на муфте; пустота = свободный вал
3. Пустота
4. 65–160 = типоразмер насоса
5. D164 = диаметр рабочего колеса
6. Пустота
7. Пустота
8. Пустота
9. Пустота
10. Материал кожуха
11. Материал рабочего колеса
12. Конфигурация материалов механического уплотнения + уплотнительного кольца
13. Свободные позиции для опций

Английска

1. ESH = тип насоса
2. Позначения на муфти; Void = вільний кінець вала
3. Void
4. 65–160 = типорозмір двигуна
5. D164 = діаметр робочого колеса
6. Void
7. Void
8. Void
9. Void
10. Матеріал корпусу
11. Матеріал робочого колеса
12. Конфігурація матеріалів збірки механічне ущільнення + ущільнювальне кільце
13. Вільні позиції для опцій

العربية

1. ESH = نوع المضخة
2. مؤشر الإقران؛ لا شيء = بدون قاعدة أو محرك
3. لا شيء
4. 65–160 = مقاس المضخة
5. D164 = قطر الدفاعة
6. لا شيء
7. لا شيء
8. لا شيء
9. لا شيء
10. مواد العلية
11. مواد الدفاعة
12. مانع التسرب الميكانيكي + تكوين المواد بحلقة دائرية
13. أرقام حرة للخيارات

3.

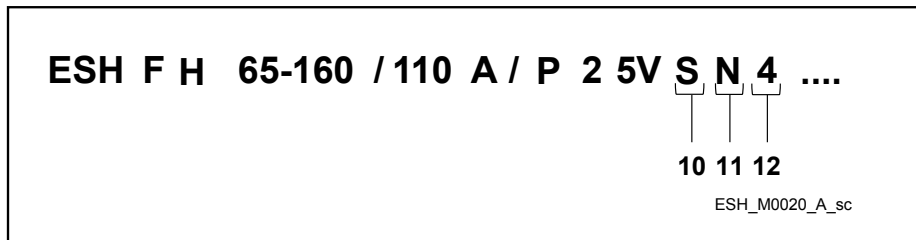

	F	G
10	S	23

- ciu/carbon/FKM • Q1BVGG: Силициев карбид/въглерод / FKM • Q1BVGG: silicijev karbid/ogljjik/FKM • Q1BVGG: Silikon karbid / ugljik / FKM • Q1BVGG: Silikon karbid / ugljenik / FKM • Q1BVGG: Καρβίδιο πυρρίτιο / άνθρακας / FKM • Q1BVGG: Silikon karbit / karbon / FKM • Q1BVGG: Карбид кремния / углерод / FKM • Q1BVGG: Карбід кременію / вуглець / FKM • Q1BVGG: كربيد السليكون / كربون / FKM
- 52 Q1Q1EGG: Carbuo di silicio/Carbuo di silicio/EPDM • Q1Q1EGG: Silicon carbide / silicon carbide / EPDM • Q1Q1EGG : Carbuo de silicium / carbuo de silicium / EPDM • Q1Q1EGG: Siliziumcarbide / Siliziumcarbide / EPDM • Q1Q1EGG: carbuo de silicio / carbuo de silicio / EPDM • Q1Q1EGG: Carboneto de silicio/carboneto de silicio/EPDM • Q1Q1EGG: Siliciumcarbide / Siliciumcarbide / EPDM • Q1Q1EGG: Siliciumkarbid / siliciumkarbid / EPDM • Q1Q1EGG: Silikonkarbid / silikonkarbid / EPDM • Q1Q1EGG: Silikonkarbid/silikonkarbid/FKM • Q1Q1EGG: Silikonkarbid/silikonkarbid/EPDM • Q1Q1EGG: piikarbid/piikarbid/EPDM • Q1Q1EGG: Kisisilkarbiður / kisisilkarbiður / EPDM • Q1Q1EGG: rānikarbiid / rānikarbiid / EPDM • Q1Q1EGG: silicija karbiðs / silicija karbiðs / EPDM • Q1Q1EGG: silicio karbidas / silicio karbidas / etilenpropileninis kaučiukas • Q1Q1EGG: węglik krzemu/ węglik krzemu/EPDM • Q1Q1EGG: Karbid křemiku / karbid křemiku / EPDM • Q1Q1EGG: Karbid kremika/ karbid kremika/EPDM • Q1Q1EGG: Szilícium-karbid / szilícium-karbid / EPDM • Q1Q1EGG: Carbură de siliciu/carbură de siliciu/EPDM • Q1Q1EGG: Силициев карбид / силициев карбид / EPDM • Q1Q1EGG: silicijev karbid/silicijev karbid/EPDM • Q1Q1EGG: Silikon karbid / silikon karbid / EPDM • Q1Q1EGG: Silikon karbid / silikon karbid / EPDM • Q1Q1EGG: Καρβίδιο πυρρίτιο / καρβίδιο πυρρίτιο / EPDM • Q1Q1EGG: Silikon karbit / silikon karbit / EPDM • Q1Q1EGG: Карбид кременія / карбид кременія / EPDM • Q1Q1EGG: Карбід кременію / карбід кременію / EPDM • Q1Q1EGG: كربيد السليكون / كربيد السليكون / EPDM
- 53 Q1Q1VGG: Carbuo di silicio/Carbuo di silicio/FKM • Q1Q1VGG: Silicon carbide / silicon carbide / FKM • Q1Q1VGG : Carbuo de silicium / carbuo de silicium / FKM • Q1Q1VGG: Siliziumcarbide / Siliziumcarbide / FKM • Q1Q1VGG: carbuo de silicio / carbuo de silicio / FKM • Q1Q1VGG: Carboneto de silicio/carboneto de silicio/FKM • Q1Q1VGG: Siliciumcarbide / Siliciumcarbide / FKM • Q1Q1VGG: Siliciumkarbid / siliciumkarbid / FPM • Q1Q1VGG: Silikonkarbid / silikonkarbid / FKM • Q1Q1VGG: Silikonkarbid/silikonkarbid/FKM • Q1Q1VGG: piikarbid/piikarbid/FKM • Q1Q1VGG: Kisisilkarbiður / kisisilkarbiður / FKM • Q1Q1VGG: rānikarbiid / rānikarbiid / FKM • Q1Q1VGG: silicija karbiðs / silicija karbiðs / FKM • Q1Q1VGG: silicio karbidas / silicio karbidas / fluorintas elastomas • Q1Q1VGG: węglik krzemu/węglik krzemu/FKM • Q1Q1VGG: Karbid křemiku / karbid křemiku / FKM • Q1Q1VGG: Karbid kremika/karbid kremika/FKM • Q1Q1VGG: Szilícium-karbid / szilícium-karbid / FKM • Q1Q1VGG: Carbură de siliciu/carbură de siliciu/FKM • Q1Q1VGG: Силициев карбид / силициев карбид / FKM • Q1Q1VGG: ogljjik/silicijev karbid/FKM • Q1Q1VGG: Silikon karbid / silikon karbid / FKM • Q1Q1VGG: Καρβίδιο πυρρίτιο / καρβίδιο πυρρίτιο / FKM • Q1Q1VGG: Silikon karbit / silikon karbit / FKM • Q1Q1VGG: Карбид кременія / карбид кременія / FKM • Q1Q1VGG: Карбід кременію / карбід кременію / FKM • Q1Q1VGG: كربيد السليكون / السليكون / FKM
- 56 VBEGG: Ceramica / Carbonio / EPDM • VBEGG: Ceramic / carbon / EPDM • VBEGG : Céramique / carbone / EPDM • VBEGG: Keramik / Kohlenstoff / EPDM • VBEGG: cerámica/carbón/EPDM • VBEGG: Cerámica/carbono/EPDM • VBEGG: Keramik / soolstof / EPDM • VBEGG: Keramik / carbon / EPDM • VBEGG: Keramik / karbon / EPDM • VBEGG: keramiskt material/kol/EPDM • VBEGG: keraaminen/hili/EPDM • VBEGG: Keramik / kolefni / EPDM • VBEGG: keraamiline / süsinik / EPDM • VBEGG: keramika / ogleklis / EPDM • VBEGG: keramika / anglis / etilenpropileninis kaučiukas • VBEGG: ceramika/węgiel/EPDM • VBEGG: Keramika/uhlík/EPDM • VBEGG: Keramika/uhlík/EPDM • VBEGG: Kerámia / szén / EPDM • VBEGG: Ceramică/carbon/EPDM • VBEGG: Керамика/въглерод/EPDM • VBEGG: keramika/ogljjik/EPDM • VBEGG: Keramika / ugljik / EPDM • VBEGG: Keramika / ugljenik / EPDM • VBEGG: Κεραμικό / άνθρακας / EPDM • VBEGG: Seramik / karbon / EPDM • VBEGG: Керамика / углерод / EPDM • VBEGG: Керамика / вуглець / EPDM • VBEGG: خزف / كربون / EPDM
- 57 VBVG: Ceramica / Carbonio / FKM • VBVG: Ceramic / carbon / FKM • VBVG : Céramique / carbone / FKM • VBVG: Keramik / Kohlenstoff / FKM • VBVG: cerámica/carbón/FKM • VBVG: Cerámica/carbono/FKM • VBVG: Keramik / koolstof / FKM • VBVG: Keramik / carbon / FKM • VBVG: Keramik / karbon / FKM • VBVG: keramiskt material/kol/FKM • VBVG: keraaminen/hili/FKM • VBVG: Keramik / kolefni / FKM • VBVG: keraamiline / süsinik / FKM • VBVG: keramika / ogleklis / FKM • VBVG: keramika / anglis / fluorintas elastomas • VBVG: ceramika/węgiel/FKM • VBVG: Keramika/uhlík/FKM • VBVG: Keramika/uhlík/FKM • VBVG: Kerámia / szén / FKM • VBVG: Ceramică/carbon/FKM • VBVG: Керамика/въглерод/FKM • VBVG: keramika/ogljjik/FKM • VBVG: Keramika / ugljik / FKM • VBVG: Keramika / ugljenik / FKM • VBVG: Κεραμικό / άνθρακας / FKM • VBVG: Seramik / karbon / FKM • VBVG: Керамика / углерод / FKM • VBVG: Керамика / вуглець / FKM • VBVG: خزف / كربون / FKM

4.

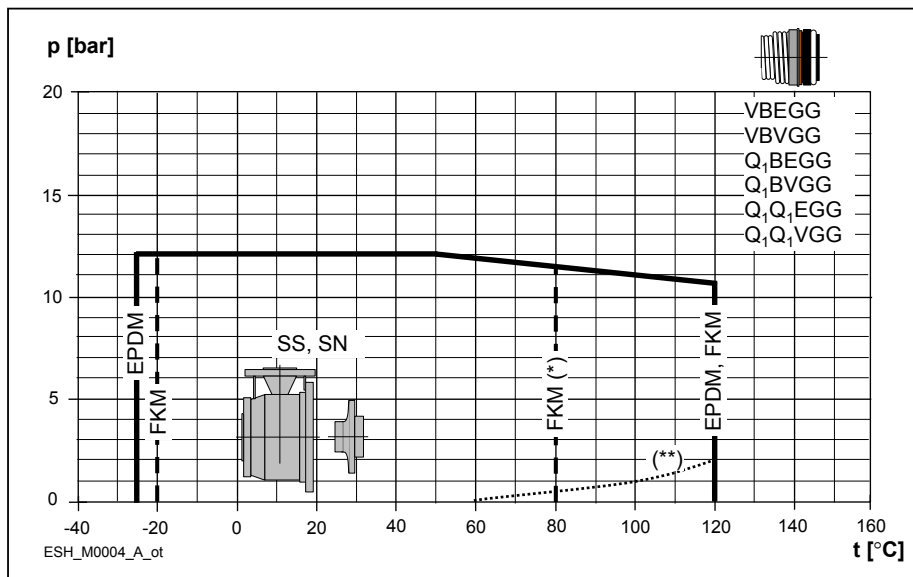

(*) acqua calda – • hot water – • eau chaude – • Heißes Wasser – • agua caliente – • água quente – • heet water – • varmt vand – • varmt vann – • varmt vatten – • kuuma vesi – • heitt vattu – • (*) kuum vesi – • Karsts ūdens – • karštas vanduo – • gorąca woda – • Horká voda – • horúca voda – • forró víz – • apă caldă – • Гореща вода – • vroča voda – • vrela voda – • vrela voda – • ζεστό νερό – • sıcak su – • горячая вода – • гаряча вода – • ماء ساخن –

(**) pressione minima richiesta alla tenuta meccanica (acqua calda); • minimum pressure required at mechanical seal (hot water); • pression minimale exigée sur le joint mécanique (eau chaude) ; • an der Gleitringdichtung (Heißwasser) minimal erforderlicher Druck; • presión mínima necesaria en el sello mecánico (agua caliente); • pressão mínima necessária no vedante mecânico (água quente); • minimale druk vereist bij mechanische sluiting (heet water); • minimum tryk krævet ved mekanisk tætning (varmt vand); • minimumalt trykk som kreves ved mekanisk tetning (varmt vann); • minsta nödvändiga tryck vid mekanisk tätning (varmt vatten); • mekaanisessa tiivisteessä tarvittava vähimmäispaine (kuuma vesi); • lágmarks þrýstingur þarf við þakkdós (heitt vatn); • minimaalne mehaanilise tihendi juures nõutav rõhk (kuum vesi); • Minimālais nepieciešamais spiediens, kas nepieciešams mehāniskās aizdares gadījumā (karsts ūdens) • minimalus slėgis, kurio reikia ties mechaniniu sandarikliu (karštas vanduo); • minimalne ciśnienie wymagane na uszczelnieniu mechanicznym (gorąca woda); • minimální tlak požadovaný pro mechanickou ucpávku (horká voda); • minimálny tlak potrebný pri mechanickej tesnení (horúca voda); • a mechanikai tömítésnél szükséges minimális nyomás (forró víz); • presiune minimă necesară la garnitura de etanșare mecanică (apă caldă); • Минимално налягане необходимо за механичното уплътнение (гореща вода); • najmanjši tlak, potreben pri mehanskem tesnilu (vroča voda); • minimalni tlak potreban na mehaničkim zatvaračima (vrela voda); • minimalni pritisak potreban na mehaničkim zatvaračima (vrela voda); • ελάχιστη πίεση που απαιτείται στη μηχανική στεγανοποίηση (ζεστό νερό). • mekanik keçede gereken minimum basınç (sıcak su); • требуется минимальное давление на механическое уплотнение (горячая вода); • потрібен мінімальний тиск на механічне ущільнення (гаряча вода); • يلزم الحد الأدنى من الضغط عند النقل الميكانيكي (ماء ساخن) ;

5.

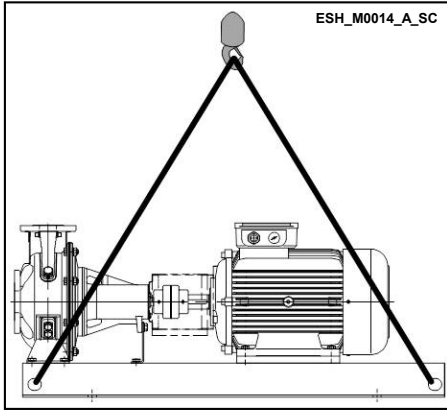

6.

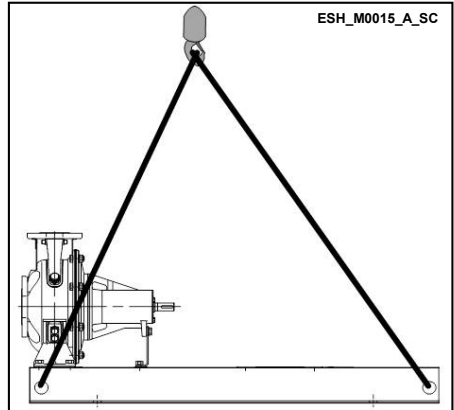

7.

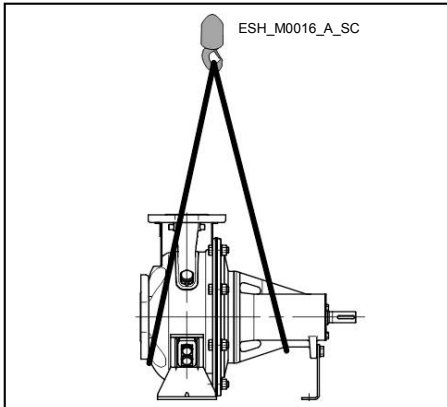

8.

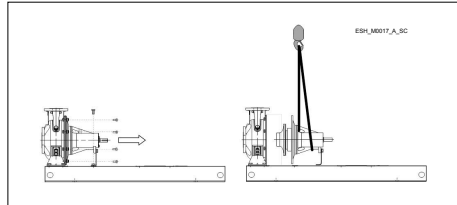

9.

~2900 min ⁻¹					
	LpA dB ± 2	LwA dB ± 2		LpA dB ± 2	LwA dB ± 2
25-125/07	< 70	-	50-125/22	< 70	-
25-125/11	< 70	-	50-125/30	< 70	-
25-160/15	< 70	-	50-125/40	< 70	-
25-160/22	< 70	-	50-160/55	< 70	-
25-200/30	< 70	-	50-160/75	< 70	-
25-200/40	< 70	-	50-200/110A	70	-
25-250/55	< 70	-	50-200/110	70	-
25-250/75	< 70	-	50-250/150	71	-
25-250/110	70	-	50-250/185	71,5	-

~2900 min-1						
32-125/07	< 70	-		50-250/220	72	-
32-125/11	< 70	-		65-160/40	< 70	-
32-160/15	< 70	-		65-160/55	< 70	-
32-160/22	< 70	-		65-160/75	< 70	-
32-200/30	< 70	-		65-160/110A	70	-
32-200/40	< 70	-		65-160/110	70	-
32-250/55	< 70	-		65-200/150	71	-
32-250/75	< 70	-		65-200/185	71,5	-
32-250/110	70	-		65-200/220	72	-
40-125/11	< 70	-		65-250/300	74	-
40-125/15	< 70	-		65-250/370	74,5	-
40-125/22	< 70	-		80-160/110	70	-
40-160/30	< 70	-		80-160/150	71	-
40-160/40	< 70	-		80-160/185	71,5	-
40-200/55	< 70	-		80-200/220	72	-
40-200/75	< 70	-		80-200/300	74	-
40-250/110A	70	-		80-200/370	74,5	-
40-250/110	70	-		80-250/450	77	-
40-250/150	71	-		80-250/550	78	-
				80-250/750	80	-

~1450 min-1						
	LpA dB ± 2	LwA dB ± 2			LpA dB ± 2	LwA dB ± 2
25-125/02A	< 70	-		50-125/02	< 70	-
25-125/02	< 70	-		50-125/03	< 70	-
25-160/02A	< 70	-		50-125/05	< 70	-
25-160/02	< 70	-		50-160/07	< 70	-
25-200/03	< 70	-		50-160/11	< 70	-
25-200/05	< 70	-		50-200/11	< 70	-
25-250/07	< 70	-		50-200/15	< 70	-
25-250/11	< 70	-		50-250/22A	< 70	-
25-250/15	< 70	-		50-250/22	< 70	-
32-125/02A	< 70	-		50-250/30	< 70	-
32-125/02	< 70	-		65-160/05	< 70	-
32-160/02A	< 70	-		65-160/07	< 70	-
32-160/02	< 70	-		65-160/11A	< 70	-
32-200/03	< 70	-		65-160/11	< 70	-
32-200/05	< 70	-		65-160/15	< 70	-
32-250/07	< 70	-		65-200/15	< 70	-
32-250/11	< 70	-		65-200/22	< 70	-
32-250/15	< 70	-		65-200/30	< 70	-

~1450 min-1						
40-125/02A	< 70	-		65-250/40	< 70	-
40-125/02	< 70	-		65-250/55	< 70	-
40-160/03	< 70	-		80-160/15	< 70	-
40-160/05	< 70	-		80-160/22A	< 70	-
40-200/07	< 70	-		80-160/22	< 70	-
40-200/11	< 70	-		80-200/30	< 70	-
40-250/11	< 70	-		80-200/40	< 70	-
40-250/15	< 70	-		80-250/55	< 70	-
40-250/22	< 70	-		80-250/75	< 70	-
				80-250/110	< 70	-

10.

~2900 min-1						
	LpA dB ± 2	LwA dB ± 2			LpA dB ± 2	LwA dB ± 2
25-125/D114	< 70	-		50-125/D114	< 70	-
25-125/D128	< 70	-		50-125/D125	< 70	-
25-160/D145	< 70	-		50-125/D137	< 70	-
25-160/D154	< 70	-		50-160/D158	< 70	-
25-200/D178	< 70	-		50-160/D174	< 70	-
25-200/D195	< 70	-		50-200/D197	< 70	-
25-250/D203	< 70	-		50-200/D197	< 70	-
25-250/D224	< 70	-		50-200/D209	< 70	-
25-250/D245	< 70	-		50-250/D224	< 70	-
32-125/D114	< 70	-		50-250/D237	70	-
32-125/D128	< 70	-		65-160/D127	< 70	-
32-160/D145	< 70	-		65-160/D140	< 70	-
32-160/D154	< 70	-		65-160/D154	< 70	-
32-200/D178	< 70	-		65-160/D164	< 70	-
32-200/D195	< 70	-		65-160/D164	< 70	-
32-250/D203	< 70	-		65-160/D176	< 70	-
32-250/D224	< 70	-		65-200/D192	< 70	-
32-250/D245	< 70	-		65-200/D203	70	-
40-125/D111	< 70	-		65-200/D210	72	-
40-125/D122	< 70	-		65-250/D240	73	-
40-125/D135	< 70	-		80-160/D169	< 70	-
40-160/D152	< 70	-		80-160/D177	< 70	-
40-160/D171	< 70	-		80-160/D186	< 70	-
40-200/D190	< 70	-		80-200/D198	70	-
40-200/D209	< 70	-		80-200/D215	72	-
40-250/D218	< 70	-		80-200/D226	73	-
40-250/D218	< 70	-		80-250/D237	74	-
40-250/D233	< 70	-		80-250/D252	75	-

~2900 min-1						
				80-250/D270	77	-

~1450 min-1						
	LpA dB ± 2	LwA dB ± 2			LpA dB ± 2	LwA dB ± 2
25-125/D114	< 70	-		50-125/D114	< 70	-
25-125/D128	< 70	-		50-125/D125	< 70	-
25-160/D145	< 70	-		50-125/D137	< 70	-
25-160/D154	< 70	-		50-160/D158	< 70	-
25-200/D178	< 70	-		50-160/D174	< 70	-
25-200/D195	< 70	-		50-200/D197	< 70	-
25-250/D203	< 70	-		50-200/D209	< 70	-
25-250/D224	< 70	-		50-250/D224	< 70	-
25-250/D245	< 70	-		50-250/D237	< 70	-
32-125/D114	< 70	-		50-250/D250	< 70	-
32-125/D128	< 70	-		65-160/D127	< 70	-
32-160/D145	< 70	-		65-160/D140	< 70	-
32-160/D154	< 70	-		65-160/D154	< 70	-
32-200/D178	< 70	-		65-160/D164	< 70	-
32-200/D195	< 70	-		65-160/D176	< 70	-
32-250/D203	< 70	-		65-200/D187	< 70	-
32-250/D224	< 70	-		65-200/D203	< 70	-
32-250/D245	< 70	-		65-200/D219	< 70	-
40-125/D122	< 70	-		65-250/D240	< 70	-
40-125/D135	< 70	-		65-250/D255	< 70	-
40-160/D152	< 70	-		80-160/D169	< 70	-
40-160/D171	< 70	-		80-160/D177	< 70	-
40-200/D190	< 70	-		80-160/D186	< 70	-
40-250/D209	< 70	-		80-200/D198	< 70	-
40-250/D218	< 70	-		80-200/D220	< 70	-
40-250/D233	< 70	-		80-250/D237	< 70	-
40-250/D251	< 70	-		80-250/D252	< 70	-
				80-250/D270	< 70	-

LpA Livelli di pressione del sonora misurati in un campo libero a un metro di distanza dall'elettropompa • Sound pressure level measured in a free field at one meter's distance from the electric pump • Niveau de pression acoustique mesurée en champ libre à une distance d'un mètre de la pompe électrique – • Der Schalldruck wurde unter Freifeldbedingungen in einem Abstand von 1 Meter von der elektrischen Pumpe gemessen. • Nivel de presión acústica medido en un campo libre a 1 m de distancia de la bomba eléctrica. • Nivel de pressão sonora medida num campo livre a um metro de distância da bomba eléctrica. • Juiste drukniveau in een vrij veld op één meter afstand tot de elektrische pomp – • Lydtryksniveau målt i et frit felt ved en meters afstand fra den elektriske pumpe – • Lydtrykksnivå målt i et fritt felt i en avstand på én meter fra den elektriske pumpen – • Ljudtrycksnivå mätt i ett öppet område på ett avstånd på 1 m från den elektriska pumpen – • Äänenpainetaso, joka on mitattu vapaassa kentässä yhden metrin etäisyydellä sähköpumpusta. • Hljóðþrýstingur mældur á opnu svæði í eins metra fjarlægð frá rafmagnsdælunni – • Heliröhu tase möödetuna tühjal väljal ühe meetri kauguselt elektripumbast. • Skapas spiediena līmenis, mērot bez ierobežojumiem viena metra attālumā no elektriskā sūkņa • Garso įtampoms lygis matuojamas nepriklausomoje zonoje vieno metro atstumu nuo elektrinio siurblio. • Poziom ciśnienia akustycznego

mierzony w warunkach pola swobodnego w odległości jednego metra od pompy elektrycznej. • Hladina akustického tlaku mēřená na volném prostranství ve vzdálenosti 1 m od elektrického čerpadla – • Hladina akustického tlaku meraná na volnom priestranstve vo vzdialenosti jedného metra od elektrického čerpadla – • A hangnyomásszint mérésére szabad területen kerül sor, az elektromos szivattyútól mért egy méteres távolságban – • Nivelul de presiune sonoră măsurat în câmp liber la un metru distanță de pompa electrică - • Нивото на налягане на звука, измерено в свободно поле на един метър разстояние от електрическата помпа. • Raven zvočnega tlaka, izmerjena v prostem polju na razdalji enega metra od električne črpalke. • Razina zvučnog tlaka izmjerena u slobodnom prostoru na udaljenosti od jednog metra od električne pumpe – • Nivo zvučnog pritiska izmeren u slobodnom prostoru na udaljenosti od jednog metra od električne pumpe. • Το επίπεδο της πίεσης του ήχου μετρημένο σε ελεύθερο πεδίο σε απόσταση ενός μέτρου από την ηλεκτρική αντλία. • Elektrik pompasından bir metre mesafede serbest bir alanda ölçülen ses basınç seviyesi. • Уровень давления звука измерен в свободном поле на расстоянии одного метра от электрического насоса • Рівень тиску звуку визначено у вільному полі на відстані один метр від електричного насоса – • مستوى الضغط المناسب المقاس في مجال خالي على مسافة متر من المضخة الكهربائية

LwA Livello di Potenza sonora (se LpA > 80 dB) • Sound power level (if LpA > 80 dB) • Niveau sonore (si LpA > 80 dB) - • Schalleistungspegel (wenn LpA > 80 dB) - • Nivel de potencia acústica (si LpA > 80 dB) - • Nivel de potencia acústica (se LpA > 80 dB) - • Juiste krachtniveau (als LpA > 80 dB) - • Lydstyrkeniveau (hvis LpA > 80 dB) - • Lydtrykknivå (hvis LpA > 80 dB) - • Ljudtrycksnivå (om LpA > 80 dB) - • Äänenpainetaso (jos LpA > 80 dB) - • Hljóðþrýstistig (ef LpA > 80 dB) - • Heli võimsustase (if LpA > 80 dB) - • Skaņas intensitātes līmenis (ja LpA > 80 dB) • Garso galios lygis (jei LpA > 80 dB) - • Poziom natężenia dźwięku (przy LpA > 80 dB) - • Hladina akustického výkonu (pokud je LpA > 80 dB) - • Hladina sily zvuku (ak je LpA > 80 dB) - • Hangteljesítmény-szint (ha LpA > 80 dB) - • Nivel putere acustică (dacă LpA > 80 dB) - • Ниво на сила на звука (ако LpA > 80 dB) - • Raven zvočne moči (če je LpA > 80 dB) - • Razina zvučne snage (ako je LpA > 80 dB) - • Nivo zvučne snage (ako je LpA > 80 dB) - • Επίπεδο ισχύος ήχου (αν LpA > 80 dB) - • Ses gücü seviyesi (LpA > 80 dB ise) - • Уровень звуковой мощности (при LpA > 80 dB) • Рівень звукової потужності (при LpA > 80 dB) - • أكبر من LpA 80 مستوى قوة الصوت (إذا كان مستوى ديبييل)

11.

H		0°C	10°C	20°C	30°C	40°C	45°C	50°C	55°C	60°C
m	ft	32°F	50°F	68°F	86°F	104°F	113°F	122°F	131°F	140°F
0	0	1,00	1,00	1,00	1,00	1,00	0,95	0,90	0,85	0,80
500	1640	1,00	1,00	1,00	1,00	1,00	0,95	0,90	0,85	0,80
1000	3280	1,00	1,00	1,00	1,00	1,00	0,95	0,90	0,85	0,80
1500	4921	0,97	0,97	0,97	0,97	0,97	0,92	0,87	0,82	0,78
2000	6561	0,95	0,95	0,95	0,95	0,95	0,90	0,85	0,80	0,76

12.

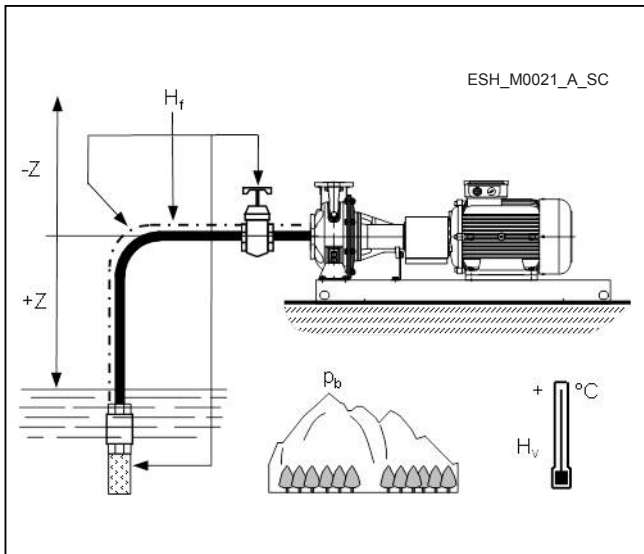

T [°C]	T [°F]	Hv [m]
20	68	0,2
30	86	0,4
40	104	0,7
50	122	1,2
60	140	2,0
70	158	3,1
80	176	4,8
90	190	7,1
100	212	10,3
110	230	14,6
120	248	20,2

13.

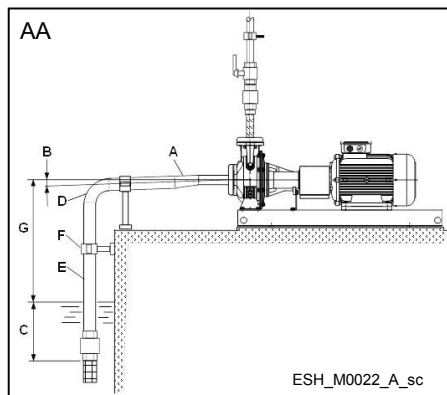

14.

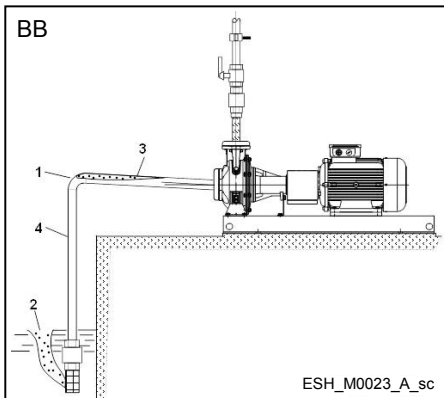

- AA Installazione corretta • **Correct installation** • Installation correcte • Korrekte Montage • Instalación correcta • Instalação correcta • Juiste installatie • Korrekt installation • Riktig installasjon • Riktig installation • Oikea asennus • Rétt uppsetning • Óige paigaldus • Pareiza uzstādīšana • Tinkamas montavimas • Popravna instalacija • Správna montáž • Správna inštalácia • Helyes beszerelés • Instalare corectă • Правилна инсталация • Právlna nameštitev • Ispravna instalacija • Pravilna instalacija • Σωστή εγκατάσταση • Doğru kurulum • Правильная установка • Правильне встановлення • التركيب الصحيح
- A Riduzione eccentrica • **Eccentric reduction** • Réduction excentrique • Exzentrische Reduzierung • Redución excéntrica • Redução excêntrica • Eccentrische reductie • Excentrisk reduktion • Ekscentrisk reduksjon • Excentrisk minskning • Epäkeskinen kokoonpuristuma • Minnkun rafragns • Ekstsentriline vähendamine • Ekscentriskā pāreja • Ekscentriskumo mažinimas • Redukcja mimośrodowa • Excentrická redukce • Excentrická redukcia • Excentrikus szűkítés • Reducție excentrică • Εκκεντρικο ρεδυκιρανε • Ekscentrična redukcija • Ekscentrično smanjenje • Ekscentrično smanjenje • Εκκεντρη μείωση • Eksantriği azaltma • Экцентрикoвый переходный патрубок • Экцентрикoвий перехідний патрубок • تقليل اللامركزية
- B Pendenza positiva • **Positive gradient** • Pente positive • Positive Neigung • Gradiente positiva • Gradiente positivo • Positieve helling • Positiv gradient • Positiv gradient • Positiv lutning • Positiivinen kaltevuus • Jäkvæður halli • Positiivne gradient • Pozitívny gradient • Teigiamaus nuolydis • Nachylenie dodatnie • Vzrůstající gradient • Kladný sklon • Pozitív lejtés • Gradient pozitiv • Положительна скала • Pozitiven naklon • Pozitivni gradijent • Pozitivni gradijent • Θετική κλίση • Pozitif eğim • Положительный градиент • Позитивний градиент • ميل ايجابي
- C Buona immersione • **Good immersion** • Bonne immersion • Gutes Eintauchen • Buena inmersión • Boa imersão • Goed ondergedompeld • Korrekt nedsænkning • Bra nedsenking • Bra nedsänkning • Hyvä upotto • Góđ dýfing • Hea sukeldamine • Pietiekama iegrimē • Tinkamas panardinimas • Dobre zanurzenie • Správne ponoření • Dobré ponorenie • Megfelelő merülés • Scufundare corectă • Добро потапяне • Dobra potopitev • Dobro potapanje • Dobro potapanje • Καλή εμφάπτιση • İyi batırma • Надлежащая глубина погружения • Налєжна глбина занурення • عمر كاف
- D Curva larga • **Large bend** • Coude grand rayon • Großer Bogen • Gran flexión • Dobra grande • Grote bocht • Stor bøining • Lang bøy • Stor bøj • Suuri mutka • Stör sveiga • Suur paine • Plats lükms • Didelis lenkimo kampas • Duży skręt • Velký ohyb • Velký ohyb • Tompa hajtas • Cot larg • Голяма сръвка • Veliko koleno • Veliki zavoј • Veliki zavoј • Καμπύλη μεγάλης ακτινας • Geniş bükme • Значительный изгиб • Значний вигин • انتناء كبير
- E Diametro tubo d'aspirazione > diametro bocca della pompa • **Suction pipe diameter > pump port diameter** • Diamètre de canalisation d'aspiration > diamètre de port de pompe • Durchmesser des Saugrohrs > Durchmesser des Pumpenstutzens • Diámetro del tubo de aspiración > diámetro de la boca de la bomba • Diámetro do tubo de sucção > diámetro da porta da bomba • Diameter aanzuigleiding > diameter pompdoor-gang • Indsugningsslangens diameter > pumpestudsens diameter • Sugerordiameter > pumpeportdiameter • Sugrórdiameter > diameterem på pumpporten • Imputken halkaisija > pumpun portin halkaisija • Þvermál sogþípu > þvermál dælimintaks • Imþumba lábimóðt > pumba pordi lábimóðt • Iesüksanas caurules diametrs > sūkņa porta diametrs • Siurbimo vamzdžio skersmuo > siurblio siurbimo angos skersmenį • Średnica rury ssąceј > Średnica portu pompy • Průměr sacího potrubí > průměr hrdla čerpadla • Priemer sacího potrubia > Priemer otvoru čerpadla • Szívócsőátmérő > szivattyúsonk átmérője • Diametru conductă de aspirație > diametru orificiū pompă • Диаметър на смукателната тръба > диаметър на порта на помпата • Premer sesalne cevi > premer vrat črpalke • Promjer usisne cijevi > promjera priključka pumpe • Prečník usisne cevi > prečnika priključka pumpe • Διάμετρος σωλήνα αναρρόφησης > Διάμετρος θύρας αντίλας •

Emme borusunun çarı ≥ Pompanın giriş çarı • Диаметр всасывающей трубы > диаметра патрубка насоса • Диаметр труби всмоктування > диаметра впускного отвору насоса • قطر أنبوب الشفط أكبر من قطر منفذ المضخة

- F Morseetto tubo • **Pipe clamp** • Bride de canalisation • Rohrschelle • Abrazadera del tubo • Grampo do tubo • Leidingklem • Rørklemmer • Rørklemme • Rörklämma • Putken kiinnitin • Rörklemma • Toruklamber • Cau-rules skava • Vamzdžio spaustuvas • Zacisk rurovy • Trubková objímka • Svoroka potrubia • Csőbillincs • Colier conductă • Скоба на помпата • Objemka cevi • Obujmovica cijevi • Stezaljka za cev • Σφιγκτήρας σωλήνα • Pompa kelepeçesi • Трубный хомут • Трубний хомут • مشبك الأنابيب
- G L'aspirazione soprabbante dipende dalla pompa e dall'installazione. In condizioni normali il dislivello non è superiore a 5-6 m. • **Suction lift depends on the pump and installation. In normal conditions it should not exceed 5 to 6 m.** • Le levage d'aspiration dépend de la pompe et de l'installation. Dans des conditions normales, elle ne devrait pas dépasser 5 à 6 m. • Saughöhe ist abhängig von der Pumpe und der Montage. Unter normalen Bedingungen sollte sie 5-6 m nicht überschreiten. • Desnivel de elevación relacionado con la bomba y con la instalación. En condiciones óptimas el desnivel no debe ser superior a 5 a 6 m. • A elevação da sucção depende da bomba e da instalação. Em condições normais não deve exceder os 5/6 m. • Zuighoogte hangt af van de pomp en de installatie. Onder normale omstandigheden dient deze niet hoger te zijn dan 5 tot 6 meter. • Sugeløft afhænger af pumpen og installationen. Ved optimale betingelser bør det ikke overskride 5 til 6 m. • Sugerløftet er afhængig af pumpen og monteringen. Ved normale forhold skal det ikke overstige 5 til 6 m. • Sughöjden beror på pumpen och installationen. Vid normala förhållanden bör den inte överstiga 5-6 m. • Imukorkeus riippuu pumpusta ja asennuksesta. Normaaliolosuhteissa tasoero se ei saa olla yli 5–6 m. • Soglifta er háð dælu og uppsetningu. Við eðlilegar aðstæður ætti hún ekki að fara yfir 5 til 6 m. • Imikörgrus oleneb pumbast ja paigaldusest. Tavatingimustes ei tohi see ületada 5 kuni 6 meetrit. • Sūkņēšanas augstums ir atkarīgs no sūkņa un uzstādīšanas. Parastos apstākļos tam nevajadzētu pārsniegt 5–6 m. • Siurbimo aukštis priklauso nuo siurblio ir montavimo. Įprastomis veikimo sąlygomis jis neturėtų viršyti 5–6 metrų. • Wysokość zasysania zależy od pompy i instalacji. W normalnych warunkach nie powinna ona przekraczać 5 - 6 m. • Sací výška je závislá na čerpadle a instalaci. Za normálních podmínek by neměla překročit 5 až 6 m. • Sacia výška závisí od daného čerpadla a jeho montáže. V běžných podmínkách by nemala presahovať 5 až 6 metrov. • A szívómagasság a szivattyútól és a telepítéstől függ. Normál feltételek esetén ez nem haladhatja meg az 5–6 m-t. • Inăltimea de aspirație depinde de pompă și de instalare. În condiții normale nu trebuie să depășească 5 până la 6 m. • Височината за засмукване зависи от помпата и инсталацията. При нормални условия тя не трябва да превишава 5 до 6 м. • Sesalno dviganje je odvisno od črpalke in namestitve. V normalnih pogojih naj ne presega od 5 do 6 m. • Usisna visina ovisi o pumpi i instalaciji. U normalnim uvjetima ne smije prelaziti 5 do 6 m. • Usisna visina zavisi od pumpe in instalacije. U normalnim uslovima ne sme prelaziti 5 do 6 m. • Η ανύψωση της αναρρόφησης εξαρτάται από την αντίλη και την εγκατάσταση. Σε κανονικές συνθήκες δεν θα πρέπει να υπερβαίνει τα 5 έως 6 m. • Emiň kavlirna pompra va kuruluma bağıldır. Normal şartlarda, 5-6 m'yi geçmemesi gerekir. • Высота всасывания зависит от насоса и его монтажа. В номинальных условиях не должна превышать 5—6 м. • Висота всмоктування залежить від насоса і його монтажу. У номінальних умовах не повинна перевищувати 5-6 м. • ارتفاع الشفط يعتمد على المضخة والتركيب. في الظروف العادية، يجب ألا يتجاوز ذلك إلى 5 إلى 6 أمتار.
- BB Installazione non corretta • **Incorrect installation** • Installation incorrecte • Falsche Montage • Instalación incorrecta • Instalação incorrecta • Onjuiste installatie • Ukorrekt installation • Feil installasjon • Felaktig installation • Virheellinen asennus • Rõng uppsetning • Vale paigaldus • Nepareiza uzstādīšana • Netinkamas montavimas • Niepoprawna instalacja • Nesprávná montáž • Nesprávna inštalácia • Helytelen beszerelés • Instalare incorectă • Неправилна инсталация • Nepravilna nameštitev • Neispravna instalacija • Nepravilna instalacija • Λάθος εγκατάσταση • Yanlış kurulum • Неправильная установка • Неправильно встановлення • التركيب غير الصحيح • التثاء حاد، مقاومة عالية التدفق
- 1 Curva stretta; elevata resistenza di flusso • **Sharp bend; high flow resistance** • Coude brusque; forte résistance au débit • Enger Bogen; hoher Durchflusswiderstand • Codo pronunciado; alta resistencia de flujo • Curva afiada; elevada resistência de fluxo • Scherpe bocht; weerstand debiet met hoge snelheid • Skarp bøjning; høj gennemstrømningsmodstand • Skarp bøy, høy strømningsmotstand • Skarp böj, högt flödesmotstånd • Terävä mutka, korkea virtausvastus • Hvöss sveigja; mikil rennsismótstaða • Järsk paine; suure voolu takistus • Ass likums; augsta plūsmas pretestība • Mažas lenkimo kampas; didelis hidraulinis pasipriešinimas • Ostry skręt; duża oporność przepływu • Ostry ohyb; vysoký odpor proudění • Ostrý ohyb, vysoký prietokový odpor • Éles tőrés; jelentős áramlási ellenállás • Cot abrupt; rezistență ridicată la flux • Остра сгъвка; висока устойчивост към потока • Ostro koleno; visoka upornost pretoka • Oštar zavoј; visoka otpornost protoku • Oštar zavoј; visoka otpornost protoku • Καμπύλη μικρής ακρίβειας, αντίσταση υψηλής ροής • Keskin bükme, yüksek akış rezistansı • Резкий изгиб; высокое сопротивление потоку • Різкий вигин; високий опір потоку
- 2 Immersione insufficiente; aspirazione aria • **Insufficient immersion; sucking air** • Immersion insuffisante; aspiration d'air • Unzureichendes Eintauchen • Luftansaugung • Imersión insuficiente; se aspira aire • Imerção insuficiente; sucção de ar • Onvoldoende ondergedompeld; zuigt lucht aan • Utilstrækkelig nedsænking; suger luft • Utilstrekkelig nedsenking, suger luft • Otiliräcklig nedsänkning, suger luft • Riittämätön upotus, imee ilmaa • Ekki nög dyfing; dregur loft að sér • Puudulik sukeldamine; õhu imemine • Nepietiekama iegrimē; tiek iesūknēts gaiss • Nepakankamas panardinimas; oro siurbimas • Niewystarczające zanurzenie; powietrze zasysania • Nedostatočné ponoření; nasávání vzduchu • Nedostatočné ponorenie, nasáva sa vzduch • Nem elégséges merülési; levegőbeszívás • Scufundare insuficientă; aspirație aer • Недостаточное

потопяне; засмукване на въздух • Nezadostna potopitev; sesanje zraka • Nedovoljno potapanje; usisavanje vazduha • Nedovoljno potapanje; usisavanje vazduha • Ανεπαρκής βύθιση, αναρρόφηση αέρα • Yetersiz batırma, hava emişi • Недостаточная глубина погружения, всасывание воздуха • Недостатна глубина занурення; всмоктування повітря • غمس غير كافٍ، شفط الهواء

- 3 Pendenza negativa; sacche d'aria • **Negative gradient; air pockets** • Pente négative ; poches d'air • Negative Neigung; Lufteinschlüsse • Gradiente negativa; bolsas de aire • Declive negativo; bolsas de ar • Negative helling; luchtzakken • Negativ gradient; luftflommer • Negativ gradien, luftflommer • Negativ lutning med luftfickor • Negatiivinen kaltevuus, ilmataskuja • Neikvæður halli; loftgöt • Negatiivne gradient; õhuauugud • Negatīvs gradients; gaisa kabatas • Neigiamas gradientas; oro kišenės • Gradient ujemny; korki powietrzne • Klesající gradient; vzduchové kapsy • Záporný gradient, vzduchové bubliny • Negativ gradiens; légzsákok • Gradient negativ; pungi de aer • Отрицателен наклон; въздушни джобове • Negativen naklon; zračni žerpi • Negativni gradijent; zračni džepovi • Negativni gradijent; vazdušni džepovi • Αρνητική κλίση, έγκλεισµα αέρα • Negatif eğim; hava sepleri • Отрицательный градиент; воздушные пробки • Негативний градієнт; повітряні пробки • ميل سلبي؛ جيوب هوائية
- 4 Diametro del tubo < diametro bocca della pompa; elevata resistenza di flusso • **Pipe diameter < pump port diameter; high flow resistance** • Diamètre de canalisation < diamètre de port de pompe ; forte résistance au débit • Rohrdurchmesser < Pumpenstutzendurchmesser; hoher Durchflusswiderstand • Diámetro del tubo < diámetro boca de la bomba; resistencia de alto flujo • Diámetro do tubo < diámetro da porta da bomba; elevada resistência de fluxo • diameter leiding < diameter pompdoorgang; weerstand debiet met hoge snelheid • Rørdiameter < pumpestudsens diameter; høj gennemstrømningsmodstand • Rørdiameter < pumpeportdiameter, høy strømningsmotstand • Rørdiameter < diameteren på pumpporten; høgt flødesmotstånd • Putken halkaisija < pumpun portin halkaisija, korkea virtausvastus • Ummál rörs < ummál dælugátar; mikil rennsliímótstaða • Toru diameeter < pumba pordi diameeter; suure voolu takistus • Caurules diametrs < sūkņa porta diametrs; augsta plūsmas pretestība • Vamzdžio skersmuo < siurblio siurbimo angos skersmenį; didelis hidraulinis pasipriešinimas • Šrednica rury < šrednica portu pompy; duża oporność przepływu • Průměr potrubí < průměr hrdla čerpadla; vysoký odpor proudění • Priemer potrubia < priemer otvoru čerpadla, vysoký prietokový odpor • Csőátmérő < szivattyúcsanak átmérője; nagy áramlási ellenállás • Diametru conductă < diametru orificiului pompei; rezistență ridicată la flux • Диаметр на тръбата < диаметър на порта на помпата; висока устойчивост на потока • Premer cevi < premer vrat črpalke; visoka upornost pretoka • Promjer cijevi < promjera priključka pumpe; visoka otpornost protoku • Prečnik cevi < prečnika priključka pumpe; visoka otpornost protoku • Диаметрос σωλήνα < διάμετρος θύρας αντλίας, αντίσταση υψηλής ροής • Boru çapı < pompa giriş çapı ; yüksek akış rezistansı • Диаметр труби < диаметра патрубкa насоса; высокое сопротивление потоку • Диаметр трубы < диаметра патрубка насоса; высокий опир потоку • قطر الأنبوب أقل من قطر منفذ المضخة؛ مقاومة عالية التدفق

15.

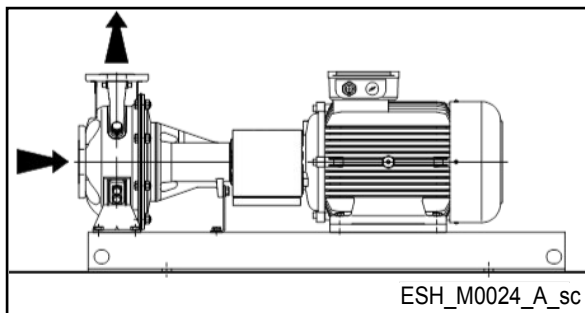

16.

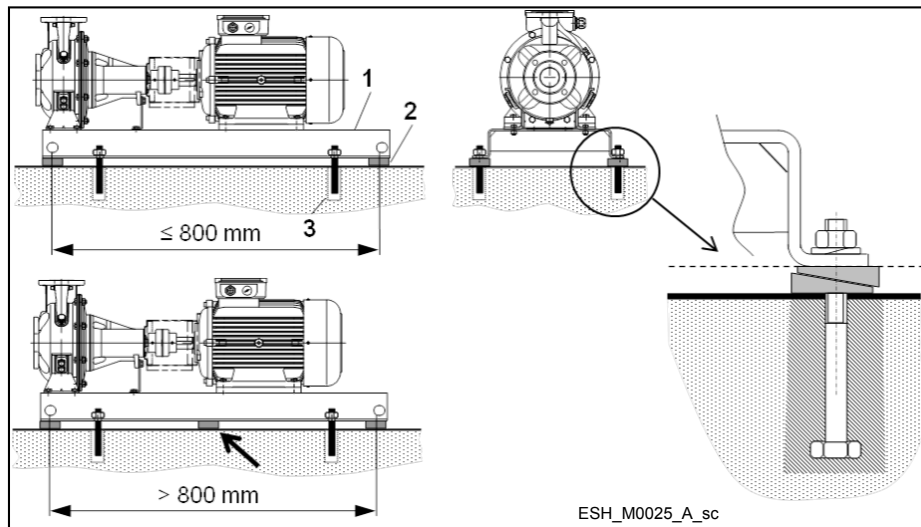

32	40	50	65	80
-125	-125	-125	-160	-160
-160	-160	-160	-200	-200
-200	-200	-200	-250	-250
-250	-250	-250		

Italiano

1. Piastra di base (set pompa)
2. Spessori
3. Bulloni della fondazione

English

1. Baseplate (pump set)
2. Shims
3. Foundation bolts

Français

1. Embase (ensemble de pompe)
2. Cales
3. Vis de fondation

Deutsch

1. Grundplatte (Pumpensatz)
2. Ausgleichsscheiben
3. Fundamentschrauben

Español

1. Plancha de base (conjunto de bomba)
2. Separadores
3. Pernos de cimentación

Português

1. Placa de base (conjunto da bomba)
2. Calços
3. Parafusos de fundação

Nederlands

1. Vloerplaat (pompestelling)
2. Pasringen
3. Funderingsbouten

Dansk

1. Bundplade (pumpesæt)
2. Mellemlægspåder
3. Fundamentbolte

Norsk

1. Sokkelplate (pumpesett)
2. Skims
3. Fundamentbolter

Svenska

1. Bottenplatta (pumpen)
2. Mellanlägg
3. Fundamentbultar

Suomi

1. Jalusta (pumppusarja)
2. Välilevyt
3. Perustuspuultit

Íslenska

1. Grunnplata (dælusett)
2. Milliplötur
3. Grunnplötuboltar

Eesti

1. Alusplaat (pumbakomplekt)
2. Kiilud
3. Alusploldid

Latviešu

1. Balstplātne (sūkņa iekārta)
2. Starplikas
3. Pamata skrūves

Lietuvių k.

1. Pagrindo plokštė (siurblio kompleksas)
2. Pleištai
3. Pagrindo varžtai

polski

1. Płyta podstawy (zespół pompy)
2. Podkładki
3. Śruby fundamentowe

magyar

1. Alaplemez (szivattyúkészlet)
2. Alátétek
3. Horgonycsavarok

Slovenščina

1. Osnovna plošča (sklop črpalke)
2. Izravnalne ploščice
3. Temeljni vijaki

Ελληνικά

1. Βάση στήριξης (σετ αντλίας)
2. Αποστάτες
3. Μπουλόνια θεμελιώσεων

Английська

1. Опорна плита (насосний агрегат)
2. Регулювальні прокладки
3. Фундаментні болти

Čeština

1. Základní deska (sada čerpadla)
2. Podložky
3. Základové šrouby

Română

1. Placă de bază (set pompa-re)
2. Garnituri de reglare
3. Buloane de fundație

Hrvatski

1. Postolje baze (pumpa)
2. Podmetači
3. Temeljni vijci

Türkçe

1. Taban plakası (pompa seti)
2. Şimler
3. Temel civatalar

Slovenčina

1. Základná doska (zostava čerpadla)
2. Vložky
3. Kotevné skrutky

Български

1. Табелка с технически данни (помпа)
2. Клинове
3. Фундаментни болтове

Srpski

1. Postolje baze (sklop pumpe)
2. Podložke
3. Temeljni zavrtnji

Русский

1. Опорная плита (насосный агрегат)
2. Регулировочные шайбы
3. Фундаментные болты

العربية

1. لوح القاعدة (مجموعة المضخة)
2. رقائق الضبط
3. مسامير الأساس

Appendice tecnica • Technical appendix • Annexe technique • Technischer Anhang • Apéndice técnico • Anexo técnico • Technische bijlage • Tehnisk bilag • Teknisk vedlegg • Tekniska appendix • Tekninen liite • Tæknilegur viðauki • Tehniline lisa • Tehniskais pielikums • Techninių duomenų priedas • Dodatek Dane techniczne • Technický dodatek • Technická príloha • Műszaki adatok függeléke • Anexă tehnică • Техническое приложение • Tehnična priloga • Tehnički dodatak • Tehnički dodatak • Τεχνικό παράρτημα • Teknik ek • Техническое приложение • Технічний додаток • الملحق الفني

17.

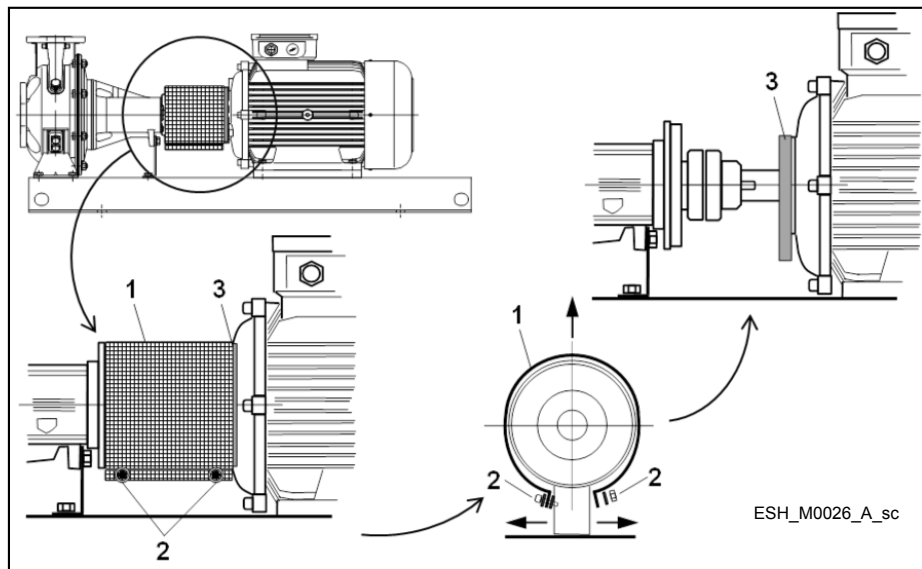

32	40	50	65	80
-125	-125	-125	-160	-160
-160	-160	-160	-200	-200
-200	-200	-200	-250	-250
-250	-250	-250		

Italiano

1. Protezione giunto
2. Dispositivi di fissaggio (viti, rondelle, dadi)
3. Anello di supporto/regolazione

English

1. Coupling guard
2. Fixing devices (screws, washers, nuts)
3. Supporting/adjusting ring

Français

1. Protecteur d'accouplement
2. Dispositifs de fixation (vis, rondelles, écrous)
3. Bague de support/réglage

Deutsch

1. Kupplungsschutz
2. Befestigungselemente (Schrauben, Unterlegscheiben, Mutttern)
3. Stütz-/Einstellring

Español

1. Protector del acoplamiento
2. Dispositivos de fijación (tornillos, arandelas, tuercas)
3. Anillo de soporte/ajuste

Português

1. Protecção de acoplamento
2. Dispositivos de fixação (parafusos, anilhas e porcas)
3. Anel de ajuste/suporte

Nederlands

1. Koppelingsbescherming
2. Bevestigingsmaterialen (schroeven, borgringen, moeren)
3. Steun-/stelring

Dansk

1. Koblingsafspærring
2. Fastgørelsesenheder (skruer, skiver, møtrikker)
3. Understøttelses-/justeringsring

Norsk

1. Koplings skjerm
2. Festeordninger (skruer, pakninger, muttere)
3. Støtte-/justeringsring

Svenska

1. Kopplingskydd
2. Fixeringsenheter (skruvar, brickor, muttrar)
3. Stöd-/justeringsring

Suomi

1. Kytkinsuojus
2. Kiinnityslaitteet (ruuvit, aluslevyt, mutterit)
3. Tuki/säätörengas

Íslenska

1. Tengjahlíf
2. Lagfæra tæki (skrúfur, skifur, rær)
3. Stuðnings/stillihringur

Eesti

1. Ühenduslüli kaitse
2. Kinnitusvahendid (kruvid, seibid, mutrid)
3. Tugi-/reguleerimisrõngas

polski

1. Osona sprzegła
2. Elementy mocujące (śruby, podkładki, nakrętki)
3. Pierścienie podpierający/regulacyjne

magyar

1. Tengelykapcsoló-burkolat
2. Rögzítőeszközök (csavarok, alátétek, anyák)
3. Alátámasztó / beállító gyűrű

Slovenščina

1. Varovalo spojke
2. Pritrdilne naprave (vijaki, podložke, matice)
3. Podporni/namestitveni obroček

Ελληνικά

1. Προστατευτικό σύζευξης
2. Συσκευές στερέωσης (βίδες, ροδέλες, παξιμάδια)
3. Δακτύλιος υποστήριξης/ρύθμισης

Английська

1. Защисний кожух муфты
2. Пристрої для кріплення (гвинти, шайби, гайки)
3. Опорне/регулювальне кільце

Latviešu

1. Savienojuma aizsargs
2. Fiksācijas ierīces (skrūves, paplāksnes, uzgriežņi)
3. Balsta/regulēšanas gredzens

Čeština

1. Jištění spojky
2. Upevňovací přípravy (šrouby, podložky, matice)
3. Podpěrný/seřizovací kruh

Română

1. Apărătoare cuplaj
2. Dispozitive de fixare (șuruburi, șaibe, piulițe)
3. Inel de susținere/reglare

Hrvatski

1. Štitnik spojke
2. Naprave za pričvršćivanje (vijci, podložke, matice)
3. Potporni prsten/prsten za podešavanje

Türkçe

1. Kuplaj mahfazası
2. Sabitleme aygıtları (vidalar, pullar, somunlar)
3. Destek/ayar halkası

Lietuvių k.

1. Movos apsauga
2. Tvirtinimo įtaisai (varžtai, porveržlės, veržlės)
3. Atraminis / reguliavimo žiedas

Slovenčina

1. Zaistenie spojky
2. Upevňovacie zariadenia (skrutky, podložky, matice)
3. Podporný/nastavovací krúžok

Български

1. Предпазител на куплунга
2. Фиксиращи устройства (винтове, гайки, шайби)
3. Опорен/коригиращ пръстен

Srpski

1. Zaštitna spojnica
2. Elementi za fiksiranje (zavrtnji, podložke, navrtke)
3. Potporni prsten/prsten za podešavanje

Русский

1. Защитный кожух муфты
2. Крепежные детали (винты, шайбы, гайки)
3. Опорное/установочное кольцо

العربية

1. واقي المقارنة
2. وسائل التثبيت (المسامير والوردات والصواميل)
3. حلقة الدعم/الضبط

18.

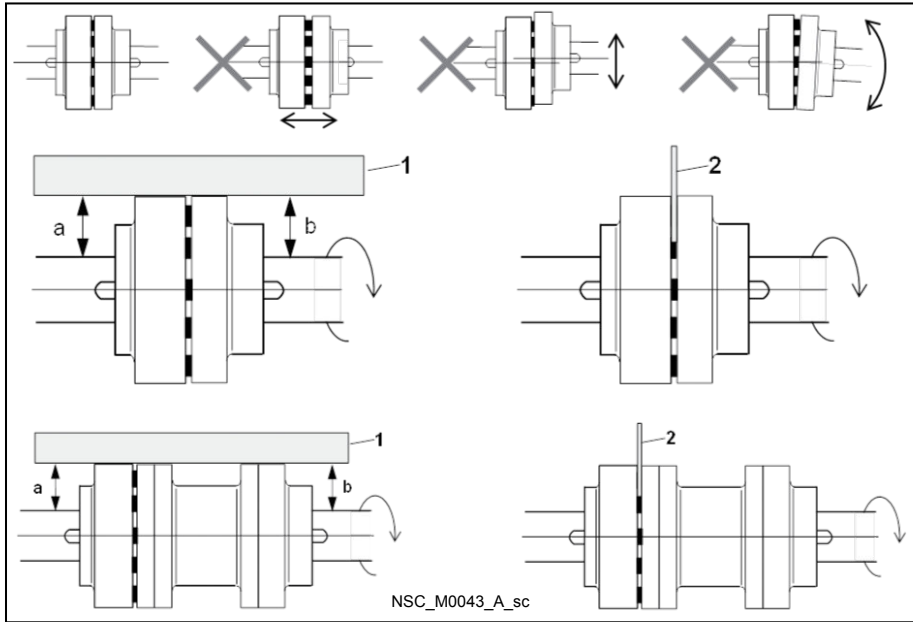
**Italiano**

1. Righello
2. Misuratore di spessore

Deutsch

1. Lineal
2. Fühlerlehre

Nederlands

1. Linaal
2. Diktemeter

Svenska

1. Linjal
2. Tjockleksmätare

Eesti

1. Joonlaud
2. Jämeduse määramise mõõteriist

polski

1. Liniał
2. Grubościomierz

magyar

1. Vonalzó
2. Vastagságmérő

English

1. Ruler
2. Thickness gauge

Español

1. Regla
2. Calibrador de espesor

Dansk

1. Lineal
2. Tykkelsesmåler

Suomi

1. Viivain
2. Rakotulkki

Latviešu

1. Lineāls
2. Biezummērs

Čeština

1. Měřítko
2. Číselníkový úchylkoměr

Română

1. Riglă
2. Șubler micrometric

Français

1. Règle
2. Jauge d'épaisseur

Português

1. Régua
2. Calibrador de espessura

Norsk

1. Linjal
2. Følelære

Íslenska

1. Reglustika
2. Þykktarmælir

Lietuvių k.

1. Liniuotė
2. Storio matuoklis

Slovenčina

1. Pravítko
2. Hrúbkomer

Български

1. Линия
2. Дебеломер

Slovenščina

1. Ravnilo
2. Merilnik debeline

Hrvatski

1. Ravnalo
2. Mjerač debljine

Srpski

1. Lenjir
2. Merač debljine

Ελληνικά

1. Κανόνας
2. Δείκτης πάχους

Türkçe

1. Cetvel
2. Sentil

Русский

1. Линейка
2. Щуп

Английска

1. Лінійка
2. Вимірювач товщини

- العربية
 1. المسطرة
 2. مقياس السمك

19.

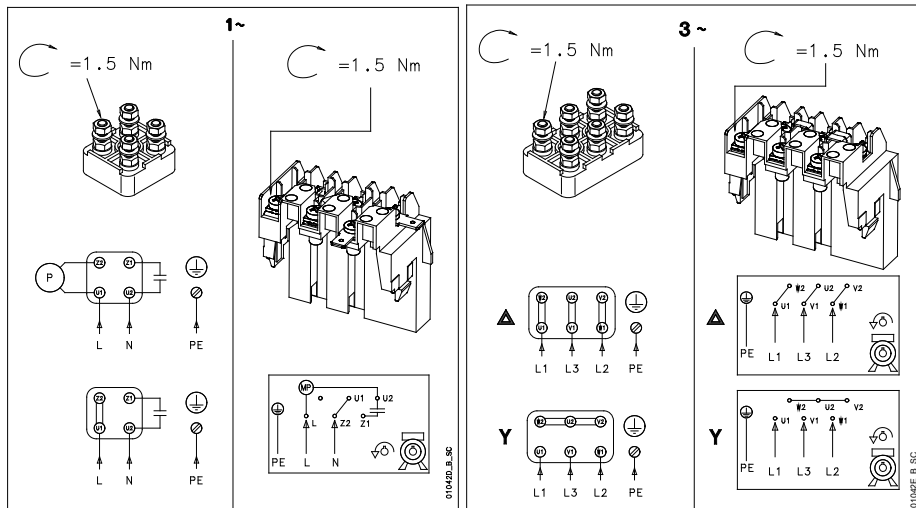

20.

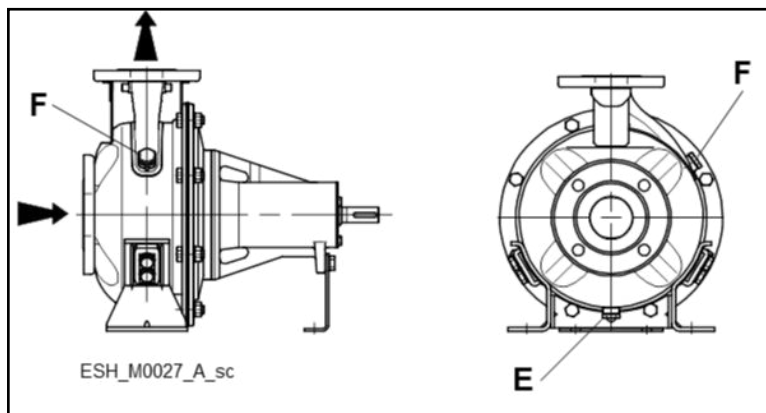

	25-125..-160..-200..-250 32-125..-160..-200..-250 40-125..-160..- 200..-250 50-125..-160..- 200..-250 65-160..- 200..-250 80-160..- 200..-250
E	G 3/8"
F	G 3/8"

- E Drenaggio • Drain • Vidange • Ablauf • Drenaje • Drenagem • Afwatering • Afløb • Drenering • Dränering • Tyhjennys • Niðurfall • Άραβool • Drenāža • Išleidimas • Spust • Vÿrust • Odtok • Üritõ • Golire • Изпразване • Odtok • Ispust • Odvod • Θυρίδα αποστράγγισης • Tahliye • Сливное отверстие • Спуск • الصرف
- F Punto di riempimento • Filling point • Point de remplissage • Füllpunkt • Punto de llenado • Ponto de enchimento • Vulpunt • Fyldningspunkt • Fyllpunkt • Páfillningspunkt • Täyttöpiste • Fyllingarstaður • Täitumispunkt • Uzpildes punkts • Pildymo anga • Punkt napetniania • Misto pro plnění • Uroveň plnenia • Feltöltési pont • Punct de umplere • Точка на пълнене • Тоčka polnjenja • Priključak za punjenje • Priključak za punjenje • Σημείο πλήρωσης • Dolma noktasi • Точка заливки • Отвір для заповнювання • نقطة التعبئة

21.

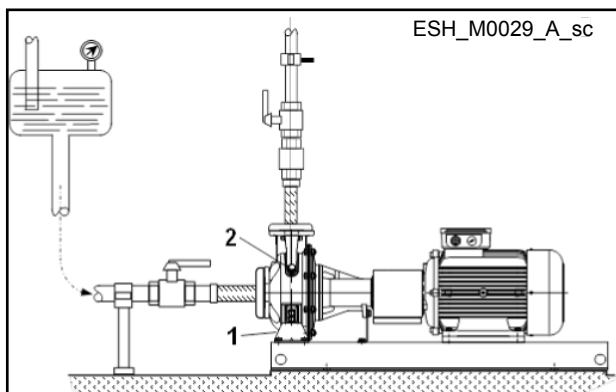
**Italiano**

1. Tappo di scarico E
2. Tappo di riempimento F

English

1. Drain plug E
2. Fill plug F

Français

1. Bouchon de vidange E
2. Bouchon de remplissage F

Deutsch

1. Ablassschraube E
2. Füllstopfen F

Español

1. Tapón de drenaje E
2. Tapón de llenado F

Português

1. Tampão de drenagem E
2. Tampão de enchimento F

Nederlands

1. Afvoerplug E
2. Vulplug

Dansk

1. Drænprop E
2. Fyldningsprop F

Norsk

1. Dreneringsplugg E
2. Fyllplugg F

Svenska

1. Avtappningsplugg E
2. Páfillningsplugg F

Suomi

1. Tyhjennystulppa E
2. Täyttötulppa F

Íslenska

1. Botntappi E
2. Áfyllingartappi F

Eesti

1. Άραβoolukork E
2. Täitekork F

Latviešu

1. Drenāžas aizgrieznis E
2. Uzpildes aizgrieznis F

Lietuvių k.

1. Išleidimo angos kamštis E
2. Pildymo angos kamštis F

polски

1. Wtyczka spustu E
2. Wtyczka napelniania F

magyar

1. Leeresztőnyílás, E
2. Feltöltőnyílás, F

Slovenščina

1. Čep za izpust E
2. Čep za polnjenje F

Ελληνικά

1. Βάνα αποστράγγισης E
2. Τάπα πλήρωσης F

Английска

1. Зливна заглушка E
2. Заливна пробка F

Čeština

1. Vypouštěcí zátka E
2. Plnicí zátka F

Română

1. Buşon de golire E
2. Buşon de umplere F

Hrvatski

1. Priključak za pražnjenje E
2. Priključak za ispunu F

Türkçe

1. Boşaltma kapağı E
2. Doldurma kapağı F

Slovenčina

1. Vypúšťacia zátka E
2. Zátka plniaceho otvoru F

Български

1. Пробка за източване E
2. Пробка за пълнене F

Srpski

1. Priključak za odvod E
2. Priključak za ispunu F

Русский

1. Дренажная заглушка E
2. Заливная пробка F

العربية

1. سداة التصريف E
2. سداة التعبئة F

22.

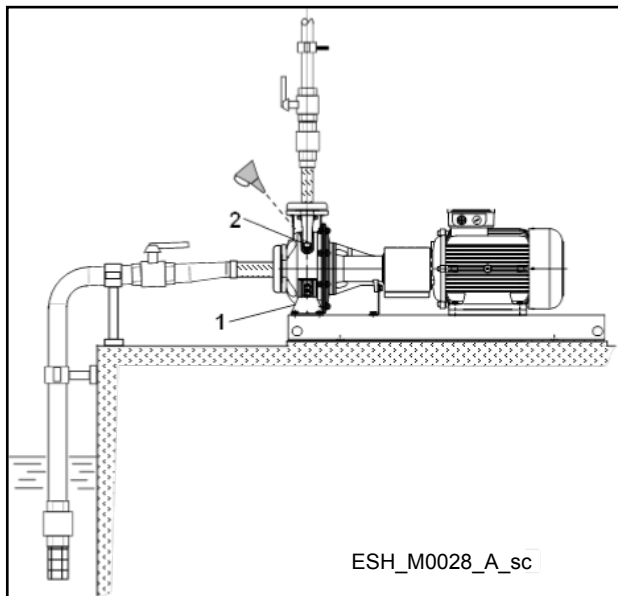

Italiano

1. Tappo di scarico E
2. Tappo di riempimento F

Deutsch

1. Ablassschraube E
2. Füllstopfen F

Nederlands

1. Afvoerplug E
2. Vulplug

English

1. Drain plug E
2. Fill plug F

Español

1. Tapón de drenaje E
2. Tapón de llenado F

Dansk

1. Drænprop E
2. Fyldningsprop F

Français

1. Bouchon de vidange E
2. Bouchon de remplissage F

Português

1. Tampão de drenagem E
2. Tampão de enchimento F

Norsk

1. Dreneringsplugg E
2. Fyllplugg F

Svenska

1. Avtappningsplugg E
2. Páfyllningsplugg F

Eesti

1. Äraavoolukork E
2. Täitekork F

polski

1. Wtyczka spustu E
2. Wtyczka napełniania F

magyar

1. Leeresztőnyílás, E
2. Feltöltőnyílás, F

Slovenščina

1. Čep za izpust E
2. Čep za polnjenje F

Ελληνικά

1. Βάνα αποστράγγισης E
2. Τάπα πλήρωσης F

Английська

1. Зливна заглушка E
2. Заливна пробка F

Suomi

1. Tyhjennystulppa E
2. Täyttötulppa F

Latviešu

1. Drenāžas aizgrieznis E
2. Uzpildes aizgrieznis F

Čeština

1. Vypouštěcí zátka E
2. Plnicí zátka F

Română

1. Bușon de golire E
2. Bușon de umplere F

Hrvatski

1. Priključak za pražnjenje E
2. Priključak za ispunu F

Türkçe

1. Boşaltma kapağı E
2. Doldurma kapağı F

Íslenska

1. Botntappi E
2. Áfyllingartappi F

Lietuvių k.

1. Išleidimo angos kamštis E
2. Pildymo angos kamštis F

Slovenčina

1. Vypúšťacia zátka E
2. Zátka plniaceho otvoru F

Български

1. Пробка за източване E
2. Пробка за пълнене F

Srpski

1. Priključak za odvod E
2. Priključak za ispunu F

Русский

1. Дренажная заглушка E
2. Заливная пробка F

العربية

1. سدادة التصريف E
2. سدادة التعبئة F



Xylem Service Italia S.r.l.
Via Vittorio Lombardi 14
Montecchio Maggiore VI
36075
Italy

© 2016 Xylem Inc

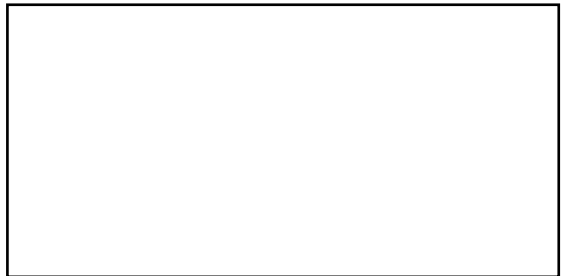

AUSTRALIAN DISTRIBUTOR



KelairPumps

CALL 1300 789 466
When Pump Knowledge Matters
www.kelairpumps.com.au