

ecocirc® BASIC-N
ecocirc® BASIC
ecocirc® PREMIUM



a címke helye

it	Istruzioni d'installazione ed uso	4
en	Installation and operating instructions	15
fr	Instructions pour l'installation et l'utilisation	26
de	Installations- und Bedienungsanleitungen	38
es	Instrucciones para la instalación y el uso	49
pt	Instruções para instalação e utilização	60
nl	Aanwijzingen voor de installatie en het gebruik	71
da	Instruktioner vedrørende installation og brug	83
no	Instruksjoner for installasjon og bruk	94
sv	Installations- och bruksanvisning	104
fi	Asennus- ja käyttöohjeet	114
cs	Návod na montáž a použití	124
hu	Telepítési és használati kézikönyv	134
ro	Instrucțiuni de instalare și de funcționare	144
ru	Инструкция по монтажу и эксплуатации	155

it	Conservate con cura il manuale per future consultazioni
en	Keep this manual for future reference
fr	Conservez avec soin le manuel pour toute consultation future
de	Das Handbuch muss für zukünftige Konsultationen sorgfältig aufbewahrt werden.
es	Guarde con cuidado el manual para poderlo consultar en el futuro
pt	Conserve cuidadosamente o manual para consultas futuras
nl	Bewaar de handleiding zorgvuldig voor latere raadpleging
da	Gem manualen til senere brug
no	Les håndboken før bruk og oppbevar den med omhu
sv	Spara bruksanvisningen för framtida bruk
fi	Säilytä käyttöopas huolellisesti
cs	Manuál uchovejte pro pozdější použití
hu	Hu Gondosan őrizze meg a kézikönyvet jövőbeni szükség esetére
ro	Păstrați acest manual pentru a-l consulta în viitor
ru	Храните это руководство для использования в будущем

These installation and operating instructions must be followed during installation and operation. Read them carefully. We recommend that you keep these instructions where the device is used. Particular attention must be paid to instructions marked as follows:



Failure to follow these instructions may lead to personal safety risks.

ATTENTION

Failure to follow these instructions may lead to the malfunction and possible damage of the device.

1. Safety instructions

This appliance is not to be used by children or persons with reduced physical, sensory or mental capabilities, or persons with a lack of experience or knowledge, unless suitably supervised or unless provided with suitable instructions so that they understood the risks originating from the usage of the appliance.



Children should be supervised at all times and should not play with appliance.

The pump must not be used with a damaged cord or enclosure.

In the event of damage to the cord, the cord must be replaced by one of the following parties: the manufacturer, its authorized service center or a professional electrician.

Other relevant regulations should also be followed: e.g. accident prevention regulations or the internal operating and safety instructions of the system manufacturer.

Failure to follow these instructions can result in the loss of all entitlements to claim damages.

2. General Description (figure 6a- 6b)

ecocirc[®] circulation pumps are shaftless spherical motor pumps with energy-efficient, electronically commutated permanent magnet technology (ECM technology) for use in hot water heating systems,

heat pumps, solar systems, air conditioning systems, closed cooling circuits and industrial circulation systems.

For technical reasons, the contact surface between the rotor and the ceramic ball bearing in spherical motor pumps is very small. For this reason, even if they have not been in operation for a long time, such as after the summer, only a small amount of torque is required to start the pump. ecocirc® pumps do not require (and thus do not have) a release/vent screw.

The ecocirc® pump can have three standard and two auxiliary operation modes:

- | | | |
|---|---|--|
| Constant Speed | = | The user can set the speed of the pump by turning the knob into any position between 1 and 7, 7 is the fastest. The preset speed remains constant, independently from the flow. |
| Proportional Pressure | = | The user can set the maximum strength of the pump by turning the knob into any position between 1 and 7, 7 is the strongest. The pump automatically decreases its speed at low flow, thus providing energy saving . |
| Constant Pressure | = | The user can set the elevation height (pressure) of the pump by turning the knob into any position between 1 and 7, 7 being the highest pressure. The preset pressure remains constant independently from the flow. |
| NOTE: Constant Pressure mode is only available in PREMIUM configuration | | |
| Automatic Air Purge | = | The user can purge the trapped air from the pumphouse. |
| Standby | = | The user can keep the power consumption low (<1W) when pump operation is not needed. |

Instructions to change between operation modes:

- To change between standard operation modes (proportional pressure constant speed and constant pressure) the user shall turn the knob until the low end position and turn the knob back to the desired setting within 5 sec. Pump indicates mode change by switching the color of the knob LED (proportional pressure is blue, constant speed is white,

constant pressure is green). In any of the normal operation cases the light is steady.

- To activate the air purge function the user shall turn the knob until the high end position and wait at least 5 seconds before turning the knob back to the desired setting. For air purge indication see section 9. After air purge cycle finishes (approximately 10 minutes) the pump will return to the previous standard operating mode.
Note: if user set the knob at the low end position pump will enter standby mode after the air purge cycle finishes.
- Returning to a standard operation mode from standby the user shall turn the knob to the desired position.

The version at hand can be determined from the name of the model.
ecocirc PREMIUM 25 – 4 / 130-N

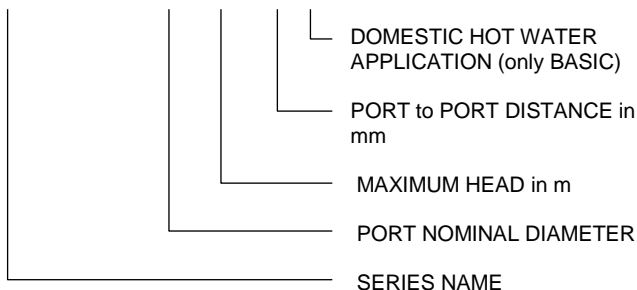

EXAMPLE: ecocirc BASIC 25-4/130 N

Electronic circulator ecocirc BASIC series, with two operation modes and no digital display, ports nominal diameter = DN25, maximum nominal head = 4 m, port-to-port distance = 130 mm, N = suitable for domestic hot water

Series	Max. delivery height	Max. delivery volume
ecocirc...-4	3.5 m	2500 l/h
ecocirc...-6	5.7 m	3200 l/h

For connection diameters see figure 1a-1b

ATTENTION The ecocirc® pumps are suitable for heating systems with power range up to approx. 50 kW (radiator heating systems up to approx. 500 m² living space, underfloor heating systems up to approx.

200 m² floor space). The power of the ecocirc[®] pump must not be adjusted by applying phase trimming ("pulsing") to the supply voltage.

3. Dimensions (see figure 1a- 1b)

4. Technical Specifications

	"ecocirc...-4"	"ecocirc...-6"
Rated voltage	200-240 V	200-240 V
Frequency	50/60 Hz	50/60 Hz
Power consumption	4-23 W	4-42 W
Energy Efficiency Index (EEI)*	see label on the front page	see label on the front page
IP protection	IP 44	IP 44
Insulation class	Class 155 (F)	Class 155 (F)
Protection class	I	I
Max. system pressure	10 bar	10 bar
Permitted temperature range of pumped fluid**	-10 °C to +110 °C	-10 °C to +110 °C
Permitted pumping media***	Heating water according to VDI 2035, water/glycol mixtures	

* The benchmark for the most efficient circulators is $EEI \leq 0.20$

** Must not freeze. To avoid condensation the fluid temperature must always be higher than the ambient temperature. For Domestic Hot Water applications the max fluid temperature is 85°C

*** Performance of the pump will noticeably change when pumping water/glycol mixtures with concentrations higher than 20%.

5. Characteristic Curves (see figure 2a + 2b +2c)

6. Installation Advice

The installation of a stop valve upstream and downstream of the pump is recommended so the pump can be replaced at a later time without the need to completely drain the system.

7. Installation



The unit must not be installed in areas where there is a danger of explosion and must not be used to pump flammable liquids.

Figure 3: Only install in dry, frost-proof rooms in one of the permitted fitting positions.

Figure 4: The use of type WD-B thermal insulation shells, available from the manufacturer, is recommended when a thermal insulation of the pump is required. When using other materials, leave the motor housing uninsulated, otherwise the electronics may overheat and the pump may automatically switch off.

Screw connections for installing the pump in the system are not included in the scope of delivery, but they may be ordered as accessories from the manufacturer.

Use new gaskets (included in the scope of delivery) when installing the pump.

The customer must take appropriate isolation measures and provide appropriate acoustic insulation to reduce possible noise transfer.

7.1 Electrical connection (see figure 7)



The unit may only be connected by an authorized electrician. The pump shall be connected to the mains power only with the plug delivered with the pump.

The proper way of connecting the plug is shown in figure 7.

A separate circuit breaker with a rated value of 10A has to be installed on the phase before the pump. .

The pump shall be connected to the electrical power with a permanent cable. No wall socket connection shall be applied.

ATTENTION

Protection class I : The pump must be grounded via connecting the grounding wire to the protective ground wire of the electrical network.

The pump has to be separable from the electrical network with a switch having minimum 3 mm connection distance and disconnecting both phase and neutral wires (overvoltage category III.)

7.2 Getting started

ATTENTION

The pump must not run dry as this can result in the destruction of the bearing in a very short time. Fill it with liquid before first start-up.

Before starting, the system must be:

- Rinsed thoroughly to prevent the presence of foreign objects and impurities which could block the pump.
- Fully filled with the pumped media (water or water-glycol mix).
- Completely purged of air.
 - To help to reach this, the pump has a built-in automatic air purge function. See instructions for activating the air purge function in section 2
 - The air purge function can be activated any time during operation when the presence of air is suspected in the system.
 - The air purge function can be activated several times in a sequence if necessary.
 - Audible flow noise indicates that there is still air in the pump.

7.3 Typical setting

The corresponding values are derived from the hydraulic calculation of the system. If this calculation is not at hand, then the following speed settings can be used:

Standard single-family home	Apartment block
(approx. 140 m ² @ 50 W/m ² = 7 kW)	(approx. 420 m ² @ 50 W/m ² = 21 kW)
ecocirc...-4 2-3	ecocirc...-6 2-3

If the temperature differential between the forward and the return is too large, increase the power; if the temperature differential is less than expected, reduce the power even further. (Guideline values: underfloor heating: 8–10 K; radiator heating: 15–20 K).

8. Maintenance/Disassembly

Pumps are subject to wear. If the pump is blocked (see section 9) or grinding noises are audible, check the pump and replace it if necessary. Procedure:

- Before any disassembly attempt, always disconnect the pump from the mains.
- Shut off supply and drain lines. If there are no shut-off devices, drain the system so that the fluid level is beneath that of the pump.
- Loosen the union nut by hand or with an appropriate tool (such as a strap wrench) and carefully pull the motor out of the pump housing.



ATTENTION

Residual water may leak out of the rotor cavity. Prevent

the pump's electrical connection from getting wet.

For figure 5:

1. Disconnect the pump from the mains voltage.
2. Loosen the union nut or take out the screws.
3. Remove the pump from the pumphouse. Be careful, some water will spill out.
4. Carefully but firmly pull the rotor / impeller upward by hand and remove it.

If necessary, remove foreign bodies and impurities/deposits with appropriate agents. Reinsert the rotor / impeller.

The bearing is worn if the rotor / impeller cannot be freely moved or if wear marks are visible. In this case, replace the rotor, the pump motor, or the entire pump.

9. Operating signal light / Troubleshooting / Warranty



Work on electrical parts may only be performed by authorized electricians on a de-energized unit.

The pump communicates its operation status or error situation via the following LED signals:

DESCRIPTION	LED CODE	ACTION
Standby state: the pump is powered, ready to run	0.75 s off/0.1 s white/0.75 s off/0.1 s blue	-
The pump is running normally	Continuously lit blue, green or white, depending on the pump operation mode (see end cover pictograms)	-
Airpurge is active	0.75 s off / 0.1 s on mode dependent color	-
Voltage or overtemperature error	1s on/1s off, mode dependent color.	Check the mains voltage Let the pump cool and restart
Overcurrent error Start error Position sensing error	0.2 s on / 0.2 s off, mode dependent color.	Check for foreign object blocking the pump rotor (Section 8)
Offset error	0.4 s off / 0.1 s on / 0.4 s off / 0.4 s on, mode dependent color	Electronics board defect, non-serviceable

Beyond the basic signal functions, ecocirc PREMIUM configuration is equipped with a digital display as well. The display provides information on the actual hydraulic performance and electrical power of the pump on the following way: The display shows the electrical power of the pump in Watts for 10 seconds, than shows the elevated water column height (differential pressure) in meters for 10 seconds, than the actual flow in m³/h for 10 seconds. Than the display returns to the energy consumption in Watts and the cycle starts again.

The PREMIUM display messages also provide detailed information on the air purge mode status as well as detailed error messages:

DISPLAY	DESCRIPTION	DEF
oFF	Pump is in standby state.	-
Lo	Pump runs, but the flow in the system is too low to measure it precisely	-
xx.x W	The display shows pump power consumption.	-
x.x m	The display shows pump head	-
x.xx m3/h	Pump flow rate. Note: flow rate is not displayed below 300 litre/h. See Lo.	-
APx	Pump is in air purge mode for 10 cycles. X= cycle count	-
E-1	Low voltage error.	Check the mains voltage
E-2	High voltage error.	Check the mains voltage
E-3	Overtemperature error.	Let the pump cool down
E-4	Overcurrent error.	Check for foreign object blocking the pump rotor (Section 8)
E-5	Motor start error.	
E-6	Position sensing error.	
E-7	Offset error.	Electronics board defect, non-serviceable

In case of loud noise from the pump, proceed as follows:

OBSERVATION	POSSIBLE REASON	ACTION
Pump is making loud noise	Not thoroughly vented	See section 7.2 "Getting Started"
	Foreign objects in pump	See section 8 "Maintenance/Disassembly"
	Worn out bearing	Replace rotor

Note regarding excessive temperatures:

In order to protect the electronics from temperatures that are dangerously high, the electronic control system monitors its own temperature. If the measured temperature is too high the pump speed is reduced. If the temperature rises above a safety limit, the pump will shut itself off. The pump will automatically restart after cooling down.

10. Disposal

This product and parts thereof must be disposed of in an environmentally friendly manner. Applicable local regulations must be followed.

11. Exploded View (see figure 6a-6b)

1. Plug for the supply cable
2. Stator/pump motor with receptacle for the plug
3. Union nut
4. O-ring
5. Impeller / Rotor
6. Pump housing
7. Continuously adjustable selector knob with built-in LED
8. Fixing screw

12. EU DECLARATION OF CONFORMITY

Apparatus model/Product: ecocirc BASIC, ecocirc PREMIUM and ecocirc BASIC-N

Name and address of the manufacturer: Xylem Service Hungary Kft.,
Külső-Kátai út 41 - 2700 Cegléd - Hungary

This declaration of conformity is issued under the sole responsibility of the manufacturer.

The object of the declaration described above is in conformity with the relevant Union harmonisation legislation:

- Directive 2014/35/EU of 26 February 2014 (LVD)

Standard used: IEC60335-2-51:2002 + A1:2008 + A2:2011
IEC60335-1:2010 + CORR.1 CORR.2
IEC62233:2005

- Directive 2014/30/EU of 26 February 2014 (EMC)

Standard used: EN61000-6-3:2007 + A1:2011
EN61000-3-2:2006 + A1:2009 + A2:2009
EN 61000-3-3:2008
EN 61000-6-2:2005
EN 61000-4-2:2009
EN 61000-4-3:2006 + A1:2008 + A2:2010
EN 61000-4-4:2012
EN 61000-4-5:2006
EN 61000-4-6:2009
EN 61000-4-8:2010
EN 61000-4-11:2004

- Directive 2009/125/EC of 21 October 2009 (Ecodesign)

Standard used: EN 16297-2

Cegléd, 01/08/2016
Amedeo Valente
Director of Innovation & Technology



Lowara is a trademark of Lowara srl Unipersonale, subsidiary of Xylem Inc.

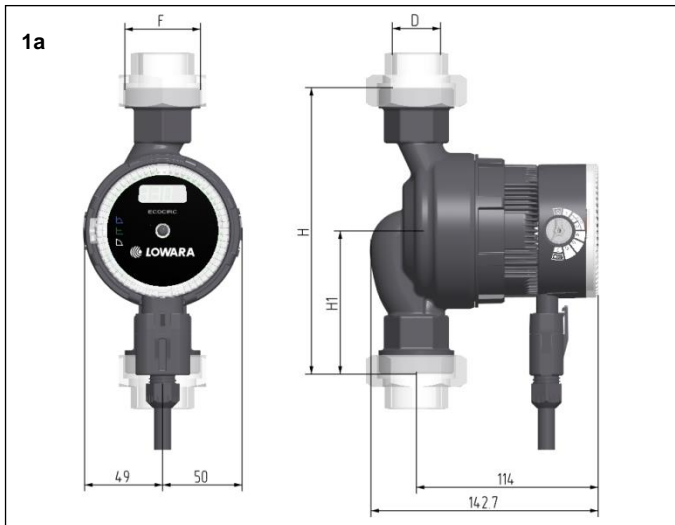

ecocirc BASIC ecocirc PREMIUM	H	H1	D	F	DN	kg
	mm					
15-4/130	130	65	R ½	R 1	15	1,9
20-4/130	130	65	R ¾	R 1¼	20	2
25-4/130	130	65	R 1	R 1½	25	2,1
25-4/180	180	90	R 1	R 1½	25	2,4
32-4/180	180	90	R 1¼	R 2	32	2,6
15-6/130	130	65	R ½	R 1	15	1,9
20-6/130	130	65	R ¾	R 1¼	20	2
25-6/130	130	65	R 1	R 1½	25	2,1
25-6/180	180	90	R 1	R 1½	25	2,4
32-6/180	180	90	R 1¼	R 2	32	2,6

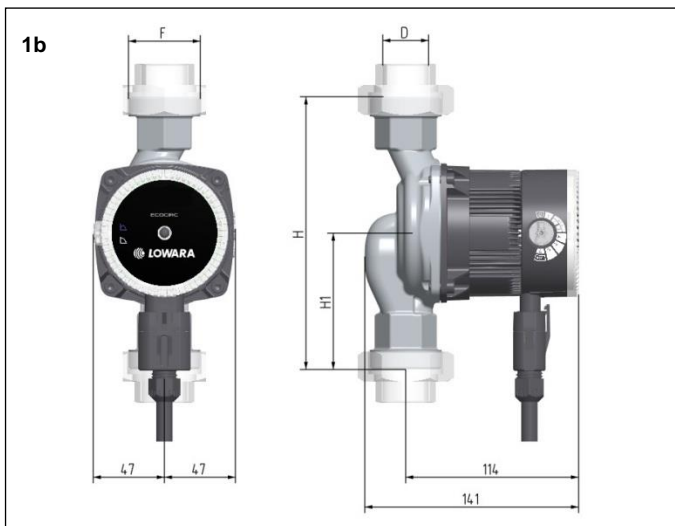

ecocirc BASIC...-N	H	H1	D	F	DN	kg
	mm					
15-4/130	130	65	R ½	R 1	15	1,9
20-4/150	150	75	R ¾	R 1¼	20	2
25-4/130	130	65	R 1	R 1½	25	2,1
25-4/180	180	90	R 1	R 1½	25	2,4
32-4/180	180	90	R 1¼	R 2	32	2,6
15-6/130	130	65	R ½	R 1	15	1,9
20-6/150	150	75	R ¾	R 1¼	20	2
25-6/130	130	65	R 1	R 1½	25	2,1
25-6/180	180	90	R 1	R 1½	25	2,4
32-6/180	180	90	R 1¼	R 2	32	2,6

2a Velocità costante - **Constant Speed** - Vitesse constante - Konstante Geschwindigkeit - Velocidad constante -

Velocidade constante - Constante snelheid - Konstant hastighed - Konstant hastighet - Konstant hastighet - Vakionopeus - Konstantní rychlost - Állandó sebesség - Vitežá constantă - Постоянная скорость

ecocirc...-4 /

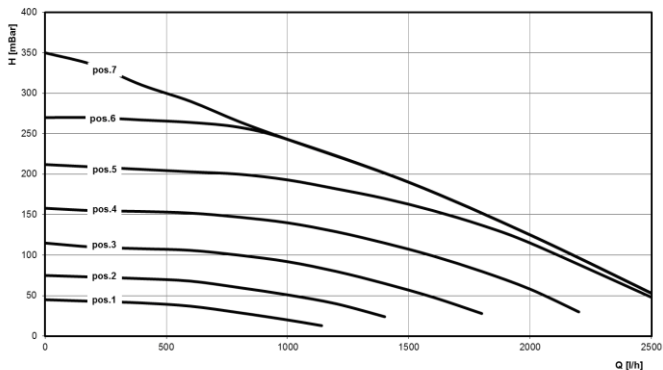

ecocirc...-6 /

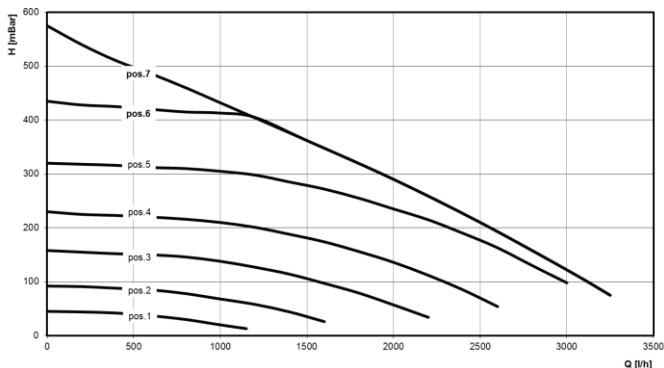

2b Pressione proporzionale - **Proportional Pressure** - Vitesse proportionnelle à la pression - Proportionaldruck - Presión

proporcional - Pressão proporcional - Proportionele druk -
 Proportionelt tryk - Proporsjonalt trykk - Proportionellt tryck -
 Suhteellinen paine - Proportionální tlak - Arányos nyomás -
 Presiune proporțională - Пропорциональное давление

ecocirc...-4 /

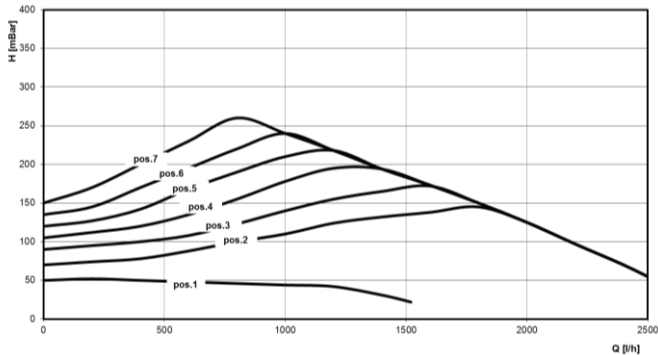

ecocirc...-6 /

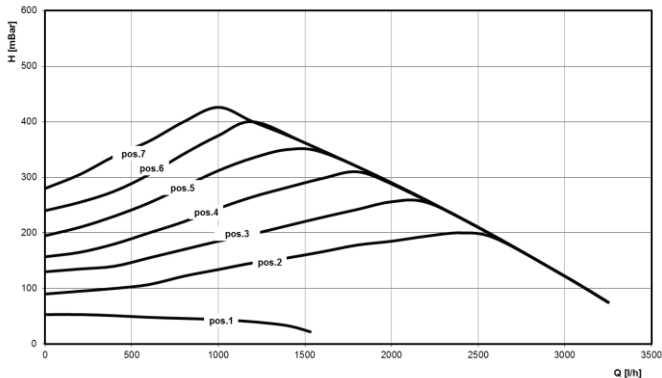

2c **Pressione differenziale costante - Constant differential pressure - Pression différentielle constante - Konstanter**

Differentialdruck - Presión diferencial constante - Pressão diferencial constante - Constant drukverschil - Konstant trykforske - Konstant differensialtrykk - Konstant differentialtryck - Vakiopaine-ero - Konstantní diferenciální tlak - Állandó differenciál nyomás - Presiune diferențială constantă - Постоянная разность давлений

ecocirc...-4 /

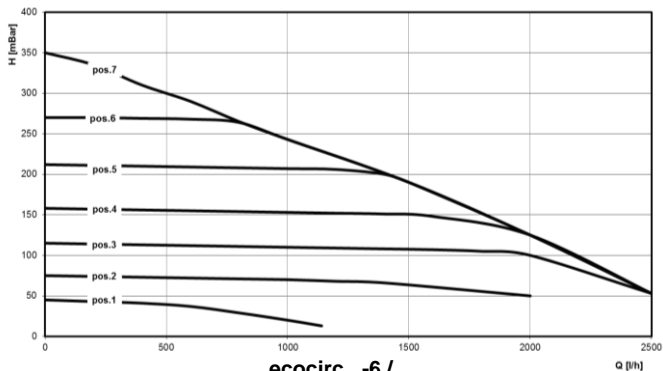

ecocirc...-6 /

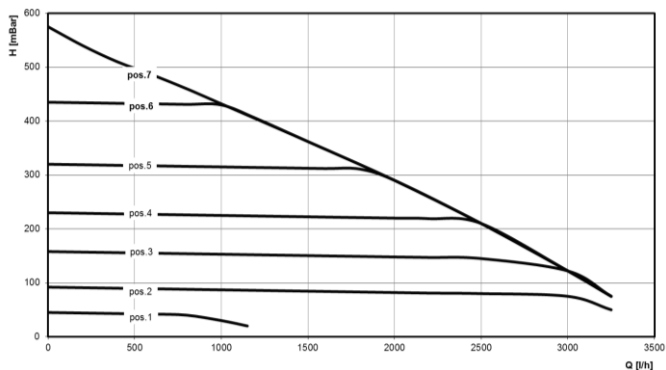

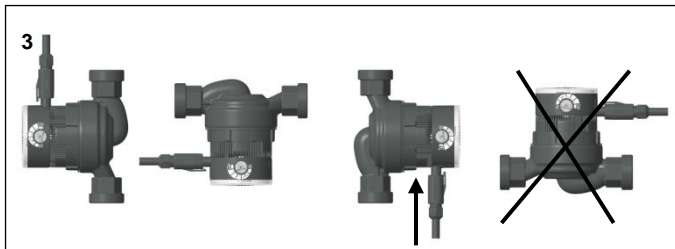

Preferibile - Preferred - Pr f r e - Bevorzugt - Preferible - Preferivel -
 Voorkeur - Anbefalet -   foretrekke -  nskv rd - Suositus -
 Preferov no - Eil nyben r szesitend  - Preferat - Рекомендуюе

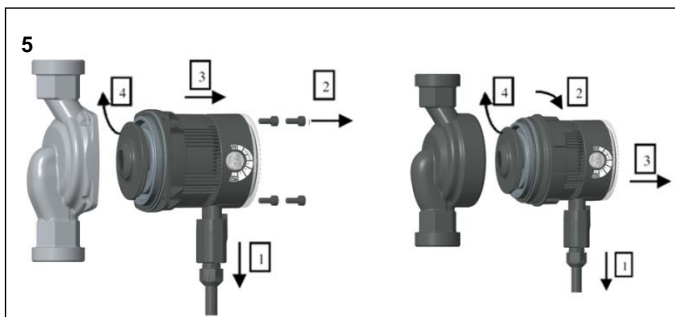

6a



6b

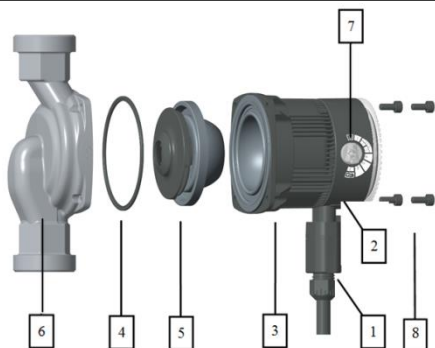

7

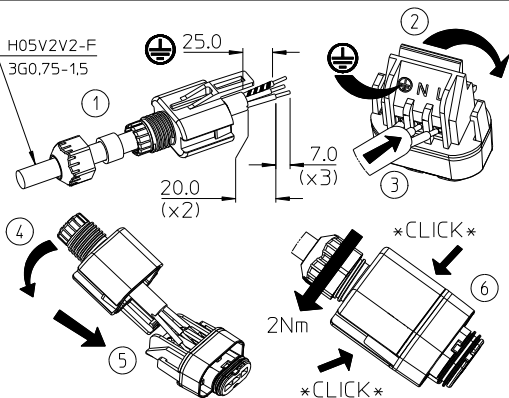

- it Xylem Service Hungary si riserva il diritto di apportare modifiche senza obbligo di preavviso.
- en Xylem Service Hungary reserves the right to make modifications without prior notice.**
- fr Xylem Service Hungary se réserve le droit d'apporter des modifications sans obligation de préavis.
- de Änderungen, auch ohne vorherige Ankündigung, sind XYLEM SERVICE HUNGARY jederzeit vorbehalten.
- es Xylem Service Hungary se reserva el derecho de realizar modificaciones sin necesidad de aviso previo.
- pt Xylem Service Hungary reserva-se o direito de efetuar modificações sem obrigação de pré-aviso.
- nl Xylem Service Hungary behoudt zich het recht voor om zonder voorafgaand bericht wijzigingen aan te brengen.
- da Xylem Service Hungary forbeholder sig retten til at ændre specifikationerne uden meddelelse herom.
- no Xylem Service Hungary forbeholder seg retten til å utføre endringer uten forvarsel.
- sv Xylem Service Hungary förbehåller sig rätten att utföra ändringar utan förhandsmeddelande.
- fi Xylem Service Hungary pidättää itselleen oikeuden tehdä muutoksia ilman ennakoilmoitusta.
- cs Xylem Service Hungary si vyhrazuje právo provádět změny bez předchozího oznámení.
- hu A Xylem Service Hungary fenntartja magának a jogot előzetes értesítés nélküli módosítások eszközésére.
- ro Lowara își rezervă dreptul de a face modificări fără notificare prealabilă.
- ru Компания Xylem Service Hungary оставляет за собой право вносить изменения без предварительного уведомления.

AUSTRALIAN DISTRIBUTOR



CALL 1300 789 466

When Pump Knowledge Matters
www.kelairpumps.com.au