

SERVICE & OPERATING MANUAL
Original Instructions



Model S30 Non-Metallic Design Level 2

Table of Contents

Engineering Data and Temperature Limitations 1
 Explanation of Pump Nomenclature 2
 Performance Curve, Model S30 Non-Metallic Design Level 2 3
 Dimensions: S30 Non-Metallic 4
 Metric Dimensions: S30 Non-Metallic 5
 Dimensions: S30 Non-Metallic with Spill Containment 6
 Metric Dimensions: S30 Non-Metallic with Spill Containment 7
 Principle of Pump Operation 8
 Installation and Start-up 8
 Air Supply 8
 Air Valve Lubrication 8
 Air Line Moisture 8
 Air Inlet and Priming 8
 Between Uses 8
 Installation Guide 9
 Important Safety Information 10
 Material Codes 11
 Troubleshooting 12
 Warranty 12
 Composite Repair Parts Drawing 13
 Overlay Option Drawing 13
 Composite Repair Parts List 14
 Spill Containment Option for Virgin PTFE Equipped Pumps 15
 Spill Containment Repair Parts List 15
 Spill Containment Concept 16
 Spill Containment Option Diaphragm Servicing 16
 Filling Spill Containment Chambers with Liquid 16
 Spill Containment Option for TPE Equipped Pumps 17
 Spill Containment Repair Parts List 17
 Spill Containment Concept with TPE Diaphragms 18
 Spill Containment Option with TPE Diaphragm 18
 Air Distribution Valve Assembly Drawing 19
 Main Air Valve Assembly Parts List 19

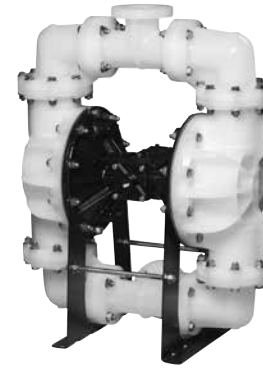

Air Distribution Valve Servicing 20
 Air Distribution Valve with Stroke Indicator Options 21
 Air Distribution Valve with Stroke Indicator Parts List 21
 Air Distribution Valve with Stroke Indicator Servicing 22
 Solenoid Shifted Air Valve Drawing 23
 Solenoid Shifted Air Valve Parts List 23
 Solenoid Shifted Air Distribution Valve Option 24
 Pilot Valve Assembly Drawing 25
 Pilot Valve Assembly Parts List 25
 Pilot Valve Servicing 26
 Diaphragm Service Drawing, Non-Overlay 27
 Diaphragm Service Drawing, with Overlay 27
 Diaphragm Servicing 28
 Overlay Diaphragm Service 28
 Pumping Hazardous Liquids 29
 Converting the pump for piping the exhaust air 29
 Exhaust Conversion Drawing 29
 Converted Exhaust Illustration 29
 Modular Check Valve Servicing 30
 Modular Check Valve Drawing 30
 Dual Port Option Drawing 31
 Dual Porting Options 32
 Dual porting of both suction and discharge ends of the pump 32
 Single porting of the suction and dual porting of the pump discharge 32
 Dual porting of the suction and single porting of the pump discharge 32
 Leak Detection Options Drawing 33
 Electronic Leak Detector Installation 33
 Mechanical Leak Detector Installation 33
 Pulse Output Kit Drawing 34
 Pulse Output Kit Option 34
 Optional Muffler Configurations, Drawing 35
 Electronic Leak Detector Installation Instructions 36
 EC Declaration of Conformity - Machinery 37

Safety Information

! IMPORTANT



Read the safety warnings and instructions in this manual before pump installation and start-up. Failure to comply with the recommendations stated in this manual could damage the pump and void factory warranty.



When the pump is used for materials that tend to settle out or solidify, the pump should be flushed after each use to prevent damage. In freezing temperatures the pump should be completely drained between uses.

! CAUTION



Before pump operation, inspect all fasteners for loosening caused by gasket creep. Retighten loose fasteners to prevent leakage. Follow recommended torques stated in this manual.



Nonmetallic pumps and plastic components are not UV stabilized. Ultraviolet radiation can damage these parts and negatively affect material properties. Do not expose to UV light for extended periods of time.



WARNING
Pump not designed, tested or certified to be powered by compressed natural gas. Powering the pump with natural gas will void the warranty.

! WARNING



When used for toxic or aggressive fluids, the pump should always be flushed clean prior to disassembly.



Before maintenance or repair, shut off the compressed air line, bleed the pressure, and disconnect the air line from the pump. Be certain that approved eye protection and protective clothing are worn at all times. Failure to follow these recommendations may result in serious injury or death.



Airborne particles and loud noise hazards. Wear eye and ear protection.



In the event of diaphragm rupture, pumped material may enter the air end of the pump, and be discharged into the atmosphere. If pumping a product that is hazardous or toxic, the air exhaust must be piped to an appropriate area for safe containment.



Take action to prevent static sparking. Fire or explosion can result, especially when handling flammable liquids. The pump, piping, valves, containers and other miscellaneous equipment must be properly grounded.



This pump is pressurized internally with air pressure during operation. Make certain that all fasteners are in good condition and are reinstalled properly during reassembly.



Use safe practices when lifting

Recycling

Many components of SANDPIPER® Conductive Acetal AODD pumps are made of recyclable materials (see chart on page 10 for material specifications). We encourage pump users to recycle worn out parts and pumps whenever possible, after any hazardous pumped fluids are thoroughly flushed.

Grounding ATEX Pumps

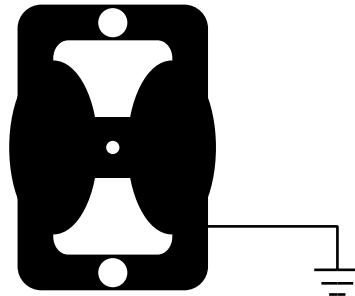

ATEX compliant pumps are suitable for use in explosive atmospheres when the equipment is properly grounded in accordance with local electrical codes. Pumps equipped with electrically conductive diaphragms are suitable for the transfer of conductive or non-conductive fluids of any explosion group. When operating pumps equipped with non-conductive diaphragms that exceed the maximum permissible projected area, as defined in EN 13461-1: 2009 section 6.7.5 table 9, the following protection methods must be applied:

- Equipment is always used to transfer electrically conductive fluids or
- Explosive environment is prevented from entering the internal portions of the pump, i.e. dry running

For further guidance on ATEX applications, please consult the factory.

**WARREN
RUPP®**

Quality System
ISO 9001 Certified

Environmental
Management System
ISO 14001 Certified

IDEX
FLUID & METERING

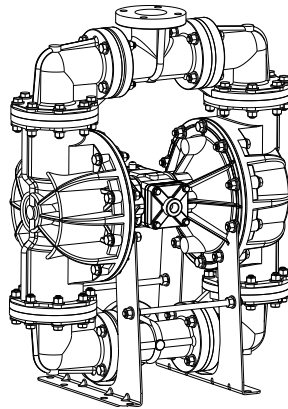

Air Inlet Side View

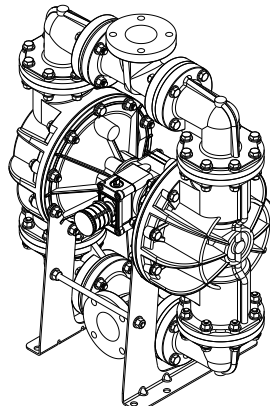

Air Exhaust Side View

CE

SANDPIPER®
A WARREN RUPP PUMP BRAND

**S30 Non-Metallic
Ball Valve**

Design Level 2

**Air Operated
Double Diaphragm Pump**

ENGINEERING, PERFORMANCE
& CONSTRUCTION DATA

INTAKE/DISCHARGE PIPE SIZE 3" ANSI Flange or 80mm DIN Flange	CAPACITY 0 to 238 US gallons per minute (0 to 901 liters per minute)	AIR VALVE No-lube, no-stall design	SOLIDS-HANDLING Up to .71 in. (18mm)	HEADS UP TO 100 psi or 231 ft. of water (7 bar or 70 meters)	DISPLACEMENT/STROKE .9 US gallon / 3.41 liter
---	---	---	--	---	---

⚠ CAUTION! Maximum Operating Temperature Limit is 180°F for Polypropylene and 250°F for PVDF Models.

Materials

	Temperature Limits	
	Maximum	Minimum
Santoprene®: Injection molded thermoplastic elastomer with no fabric layer. Long mechanical flex life. Excellent abrasion resistance.	275°F 88°C	-40°F -40°C
Virgin PTFE: Chemically inert, virtually impervious. Very few chemicals are known to react chemically with PTFE: molten alkali metals, turbulent liquid or gaseous fluorine and a few fluoro-chemicals such as chlorine trifluoride or oxygen difluoride which readily liberate free fluorine at elevated temperatures.	350°F 177°C	-35°F -37°C
Polypropylene	180°F 82°C	32°F 0°C
PVDF	250°F 121°C	0°F -18°C

For specific applications, always consult "Chemical Resistance Chart" Technical Bulletin

CAUTION: Nonmetallic pumps and plastic components are not UV stabilized. Ultraviolet radiation can damage these parts and negatively affect material properties. Do not expose to UV light for extended periods of time.

SANDPIPER® pumps are designed to be powered only by compressed air.

Maximum and Minimum Temperatures are the limits for which these materials can be operated. Temperatures coupled with pressure affect the longevity of diaphragm pump components. Maximum life should not be expected at the extreme limits of the temperature ranges.

Explanation of Pump Nomenclature

S30 Non-Metallic · Design Level 2· Ball Valve

MODEL	Pump Brand	Pump Size	Check Valve Type	Design Level	Wetted Material	Diaphragm/ Check Valve Materials	Check Valve Seat	Non-Wetted Material Options	Porting Options	Pump Style	Pump Options	Kit Options	Shipping Weight lbs. (kg)
S30B2P1PQAS000.	S	30	B	2	P	1	P	Q	A	S	0	00.	231 (105)
S30B2P2PQAS000.	S	30	B	2	P	2	P	Q	A	S	0	00.	231 (105)
S30B2K1KQAS000.	S	30	B	2	K	1	K	Q	A	S	0	00.	315 (143)
S30B2K2KQAS000.	S	30	B	2	K	2	K	Q	A	S	0	00.	315 (143)
S30B2P4PQAV000.	S	30	B	2	P	4	P	Q	A	V	0	00.	270 (122)
S30B2K4KQAV000.	S	30	B	2	K	4	K	Q	A	V	0	00.	354 (161)

Pump Brand

S= SANDPIPER®

Pump Size

30=3"

Check Valve Type

B= Ball

Design Level

2= Design Level 2

Wetted Material

K= PVDF

P= Polypropylene

Diaphragm Check Valve Materials

1= Santoprene/Santoprene

2= PTFE-Santoprene Backup/PTFE

3= PTFE Pumping, PTFE-Santoprene Backup Driver/PTFE

4= Santoprene Pumping, Santoprene Driver/Santoprene

Check Valve Seat

K= PVDF

P= Polypropylene

U= Polyurethane/ Polyurethane

Non-Wetted Material Options

A= Painted Aluminum

J= Painted Aluminum PTFE

Q= Epoxy Coated Aluminum

K= PTFE Coated Aluminum

L= PTFE Coated Aluminum with PTFE Coated Hardware

R= Epoxy Coated Aluminum with PTFE Coated Hardware

Porting Options

A= ANSI Flange

D= DIN Flange

7= Dual Porting (ANSI)

8= Top Dual Porting (ANSI)

9= Bottom Dual Porting (ANSI)

Pump Style

D= Spill Containment with Electronic Leak Detection (110V)

E= Spill Containment with Electronic Leak Detection (220V)

M= Spill Containment with Mechanical Leak Detection

S= Standard

V= Spill Containment with Visual Leak Detection

Pump Options

0= None

Kit Options

00.= None

P0.= 10-30VDC Pulse Output Kit

P1.= Intrinsically-Safe 5-30VDC, 110/120VAC, 220/240VAC Pulse Output Kit

P2.= 110/120 or 220/240VAC Pulse Output Kit

E0.= Solenoid Kit with 24VDC Coil

E1.= Solenoid Kit with 24VDC Explosion-Proof Coil

E2.= Solenoid Kit with 24VAC/12VDC Coil

E3.= Solenoid Kit with 12VDC Explosion-Proof Coil

E4.= Solenoid Kit with 110VAC Coil

E5.= Solenoid Kit with 110VAC, 60 Hz Explosion-Proof Coil

E6.= Solenoid Kit with 220VAC Coil

E7.= Solenoid Kit with 220VAC, 60 Hz Explosion-Proof Coil

E8.= Solenoid Kit with 110VAC, 50 Hz Explosion-Proof Coil

E9.= Solenoid Kit with 230VAC, 50 Hz Explosion-Proof Coil

SP.= Stroke Indicator Pins

Performance Curve, Model S30 Non-Metallic Design Level 2

Performance based on the following: elastomer fitted pump, flooded suction, water at ambient conditions.
The use of other materials and varying hydraulic conditions may result in deviations in excess of 5%.

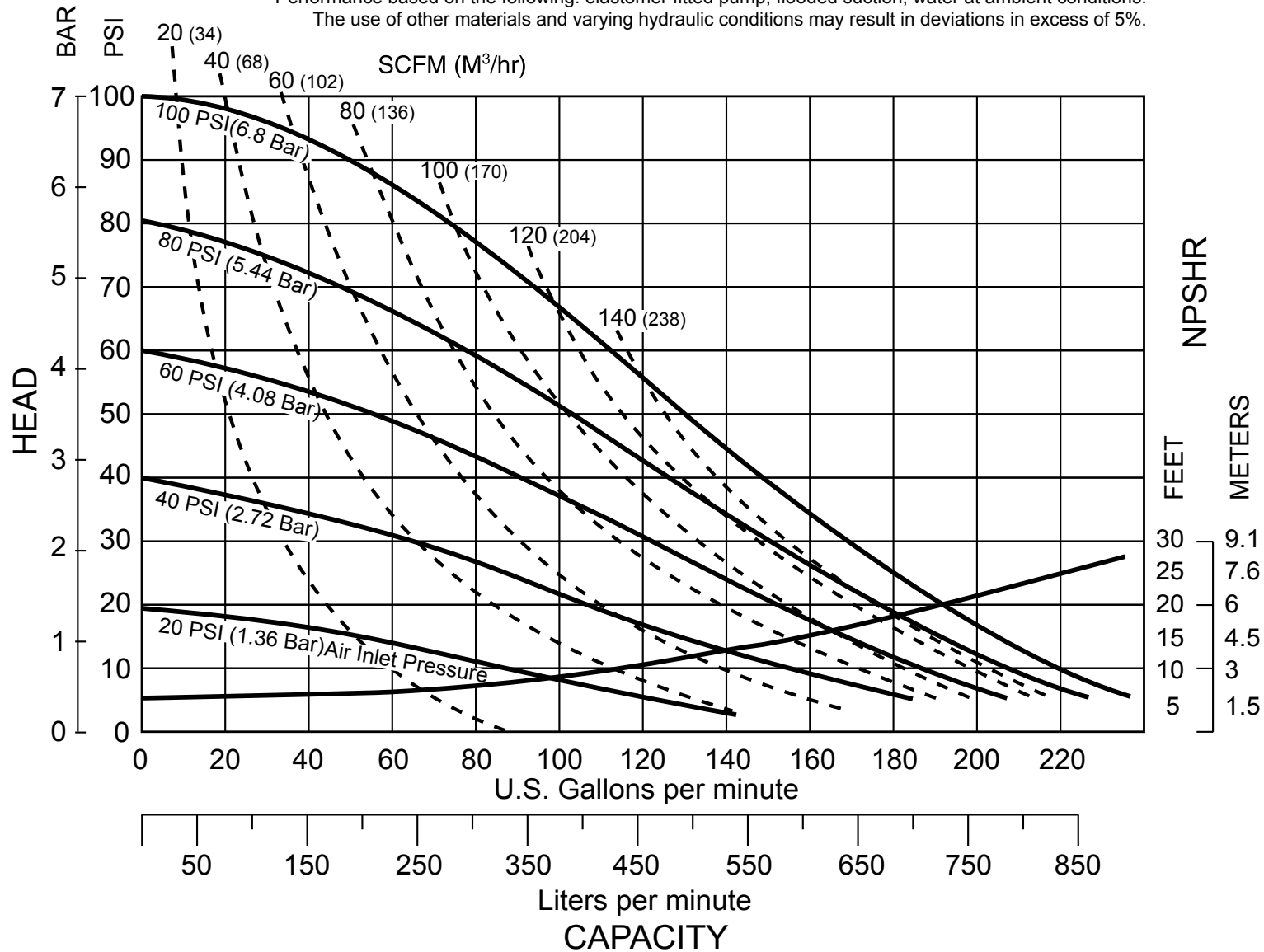

Dimensions: S30 Non-Metallic

Dimensions in Inches

Dimensional tolerance: $\pm 1/8"$

Note: Dimensions "A" is from the vertical center line to the end of the muffler.

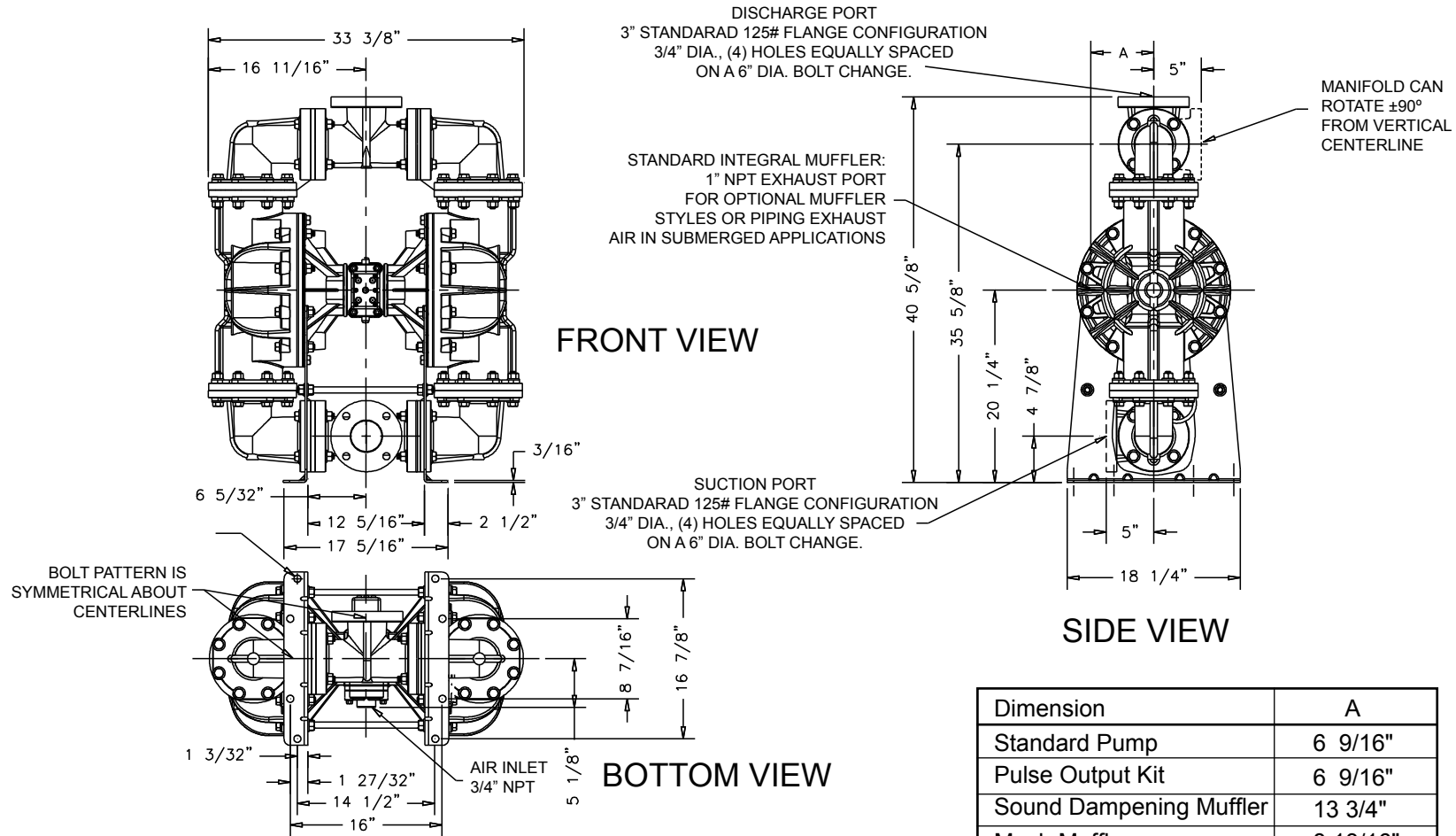

Dimension	A
Standard Pump	6 9/16"
Pulse Output Kit	6 9/16"
Sound Dampening Muffler	13 3/4"
Mesh Muffler	8 13/16"

Note: Porting Flanges are also available with PN10 80mm DIN bolting configuration.

Metric Dimensions: S30 Non-Metallic

Dimensions in Millimeters

Dimensional tolerance: $\pm 3\text{mm}$

Note: Dimensions "A" is from the vertical center line to the end of the muffler.

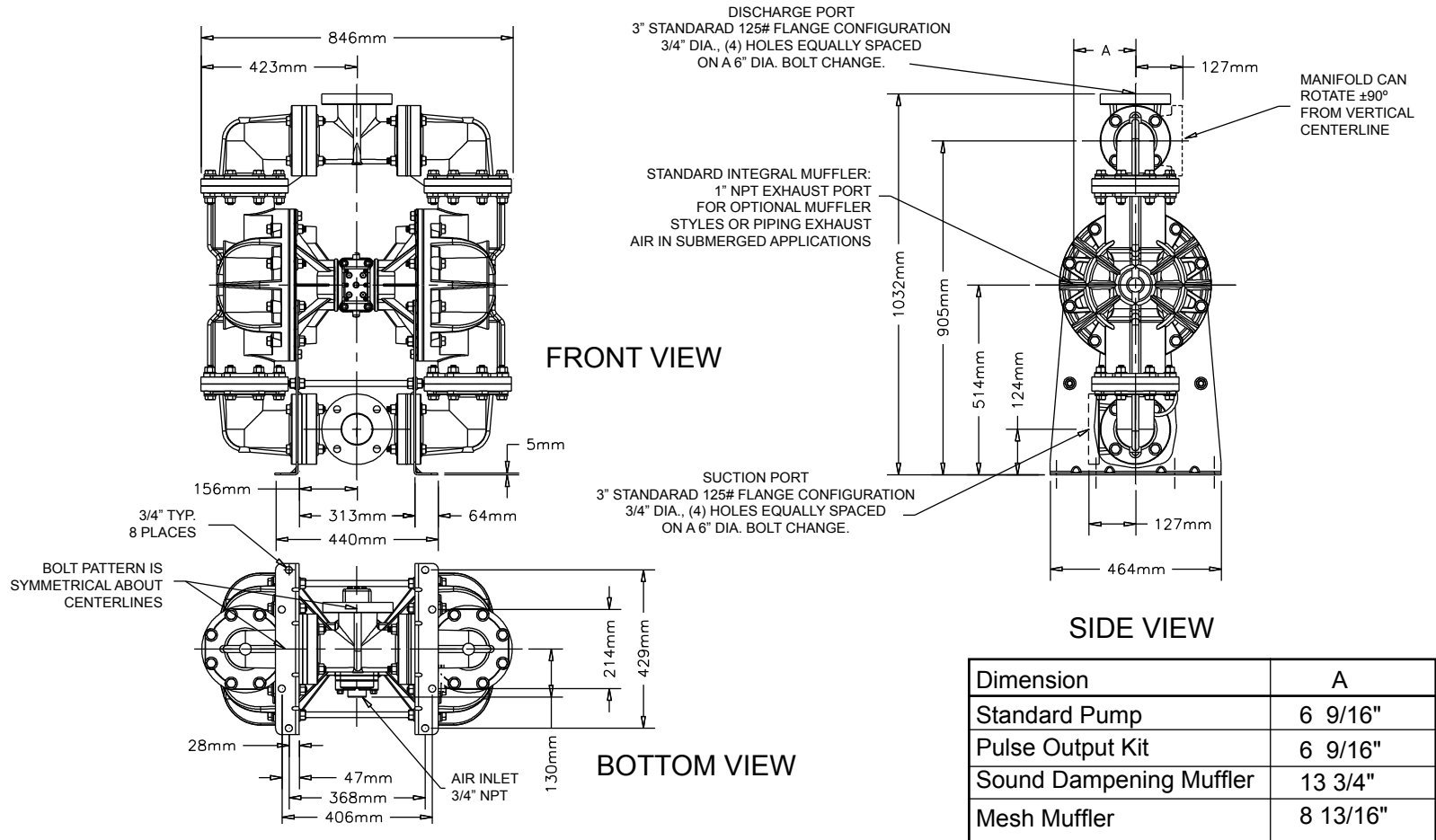

Note: Porting Flanges are also available with PN10 80mm DIN bolting configuration.

Dimensions: S30 Non-Metallic with Spill Containment

Dimensions in Inches
Dimensional tolerance: $\pm 1/8$ "

Note: Dimensions "A" is from the vertical center line to the end of the muffler.

Note: Dimensions "B" is from the opposite side of the pump to the end of the muffler.

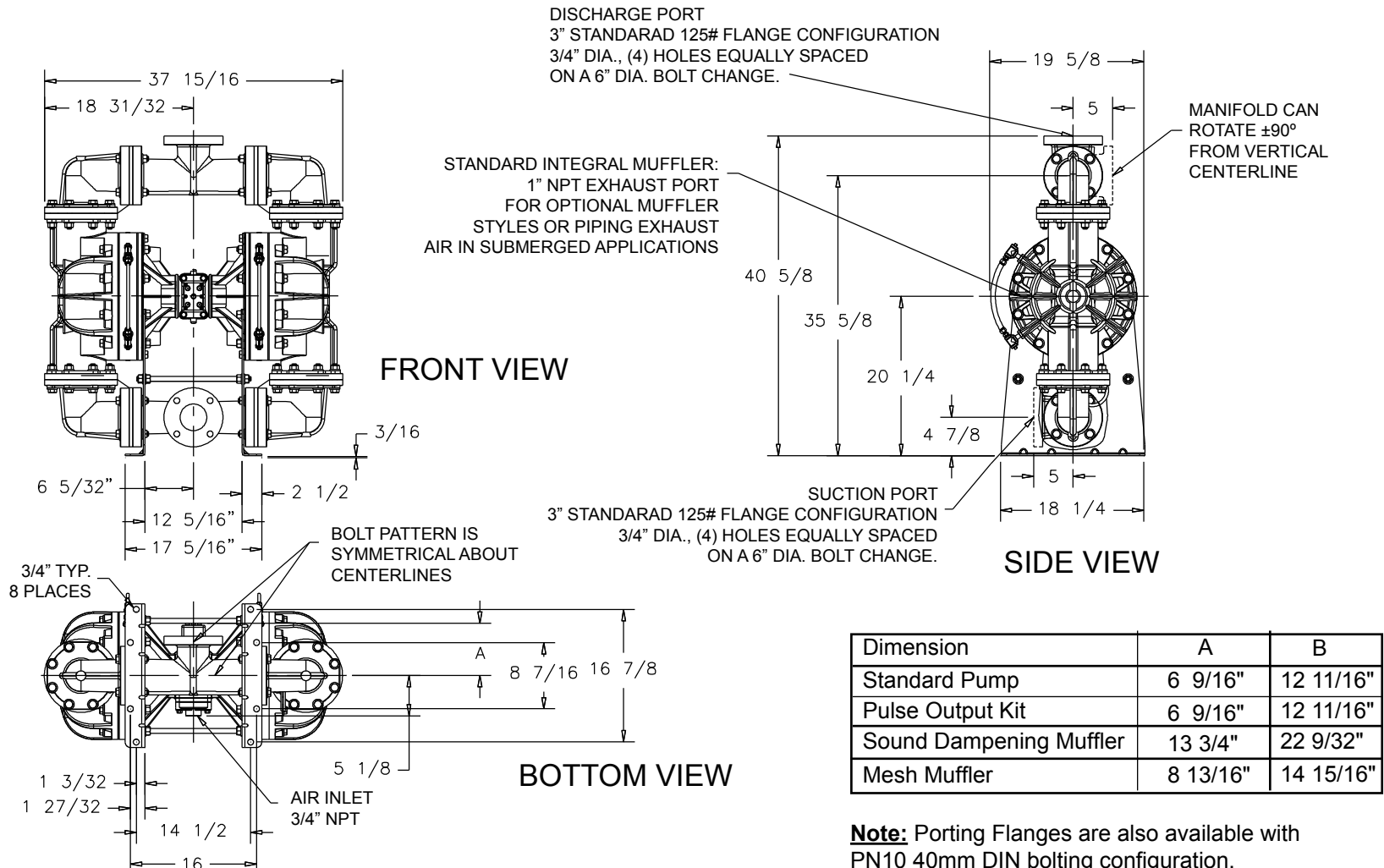

Metric Dimensions: S30 Non-Metallic with Spill Containment

Dimensions in Millimeters
Dimensional tolerance: $\pm 3\text{mm}$

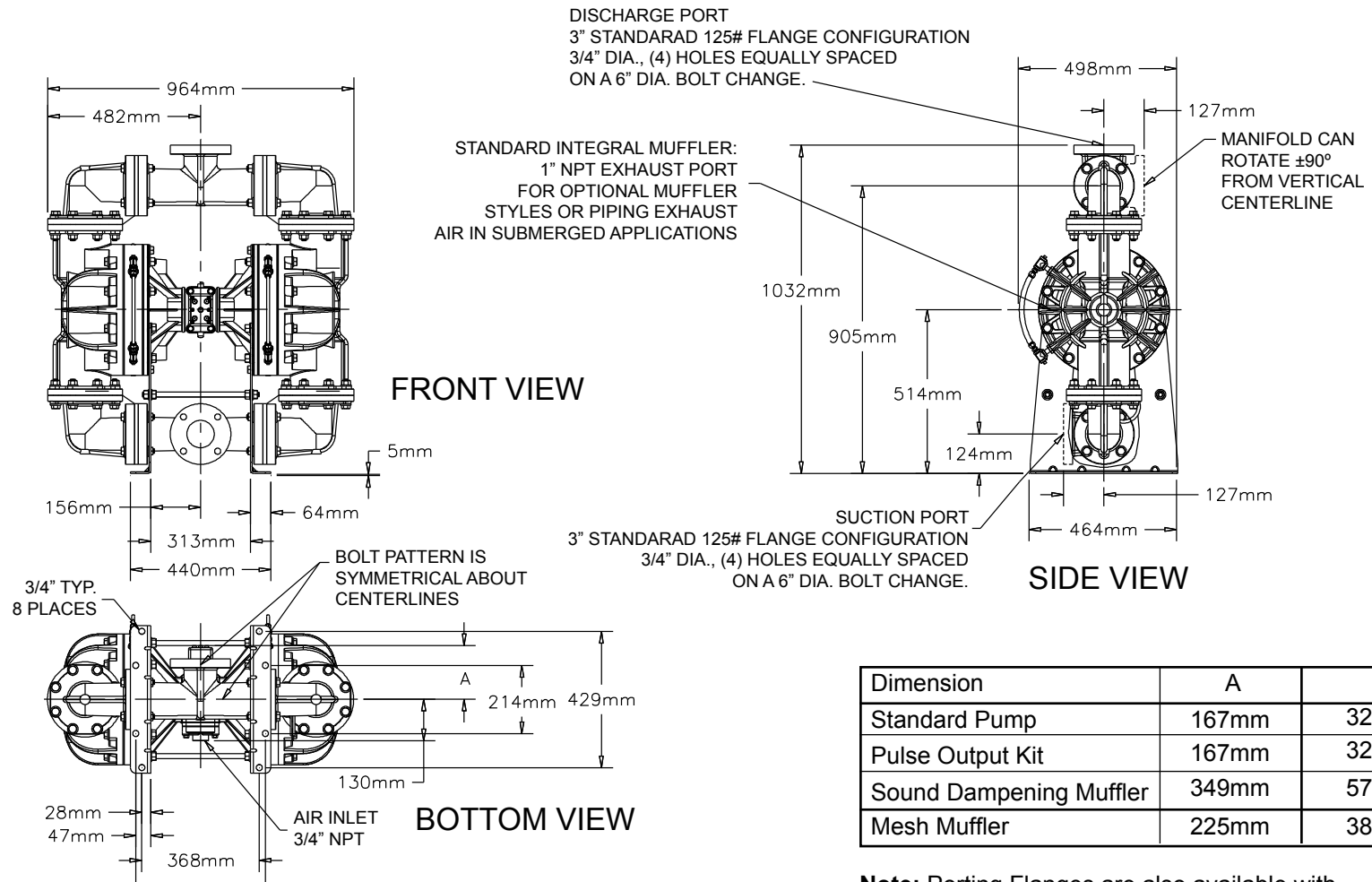

Dimension	A	B
Standard Pump	167mm	322mm
Pulse Output Kit	167mm	322mm
Sound Dampening Muffler	349mm	579mm
Mesh Muffler	225mm	380mm

Note: Porting Flanges are also available with PN10 80mm DIN bolting configuration.

PRINCIPLE OF PUMP OPERATION

This ball type check valve pump is powered by compressed air and is a 1:1 ratio design. The inner side of one diaphragm chamber is alternately pressurized while simultaneously exhausting the other inner chamber. This causes the diaphragms, which are connected by a common rod secured by plates to the centers of the diaphragms, to move in a reciprocating action. (As one diaphragm performs the discharge stroke the other diaphragm is pulled to perform the suction stroke in the opposite chamber.) Air pressure is applied over the entire inner surface of the diaphragm while liquid is discharged from the opposite side of the diaphragm. The diaphragm operates in a balanced condition during the discharge stroke which allows the pump to be operated at discharge heads over 200 feet (61 meters) of water.

For maximum diaphragm life, keep the pump as close to the liquid being pumped as possible. Positive suction head in excess of 10 feet of liquid (3.048 meters) may require a back pressure regulating device to maximize diaphragm life.

Alternate pressurizing and exhausting of the diaphragm chamber is performed by an externally mounted, pilot operated, four way spool type air distribution valve. When the spool shifts to one end of the valve body, inlet pressure is applied to one diaphragm chamber and the other diaphragm chamber exhausts. When the spool shifts to the opposite end of the valve body, the pressure to the chambers

is reversed. The air distribution valve spool is moved by a internal pilot valve which alternately pressurizes one end of the air distribution valve spool while exhausting the other end. The pilot valve is shifted at each end of the diaphragm stroke when a actuator plunger is contacted by the diaphragm plate. This actuator plunger then pushes the end of the pilot valve spool into position to activate the air distribution valve.

The chambers are connected with manifolds with a suction and discharge check valve for each chamber, maintaining flow in one direction through the pump.

INSTALLATION AND START-UP

Locate the pump as close to the product being pumped as possible. Keep the suction line length and number of fittings to a minimum. Do not reduce the suction line diameter.

For installations of rigid piping, short sections of flexible hose should be installed between the pump and the piping. The flexible hose reduces vibration and strain to the pumping system. A surge suppressor is recommended to further reduce pulsation in flow.

AIR SUPPLY

Air supply pressure cannot exceed 100 psi (7 bar). Connect the pump air inlet to an air supply of sufficient capacity and pressure required for desired performance. When the air supply line is solid piping, use a short length of flexible hose not less than ½" (13mm) in diameter between the pump and the piping to reduce strain to the

piping. The weight of the air supply line, regulators and filters must be supported by some means other than the air inlet cap. Failure to provide support for the piping may result in damage to the pump. A pressure regulating valve should be installed to insure air supply pressure does not exceed recommended limits.

AIR VALVE LUBRICATION

The air distribution valve and the pilot valve are designed to operate WITHOUT lubrication. This is the preferred mode of operation. There may be instances of personal preference or poor quality air supplies when lubrication of the compressed air supply is required. The pump air system will operate with properly lubricated compressed air supply. Proper lubrication requires the use of an air line lubricator (available from Warren Rupp) set to deliver one drop of SAE 10 non-detergent oil for every 20 SCFM (9.4 liters/sec.) of air the pump consumes at the point of operation. Consult the pump's published Performance Curve to determine this.

AIR LINE MOISTURE

Water in the compressed air supply can create problems such as icing or freezing of the exhaust air, causing the pump to cycle erratically or stop operating. Water in the air supply can be reduced by using a point-of-use air dryer to supplement the user's air drying equipment. This device removes water from the compressed air supply and alleviates the icing or freezing problems.

AIR INLET AND PRIMING

To start the pump, open the air valve approximately ½ to ¾ turn. After the pump primes, the air valve can be opened to increase air flow as desired. If opening the valve increases cycling rate, but does not increase the rate of flow, cavitation has occurred. The valve should be closed slightly to obtain the most efficient air flow to pump flow ratio.

BETWEEN USES

When the pump is used for materials that tend to settle out or solidify when not in motion, the pump should be flushed after each use to prevent damage. (Product remaining in the pump between uses could dry out or settle out. This could cause problems with the diaphragms and check valves at restart.) In freezing temperatures the pump must be completely drained between uses in all cases.

INSTALLATION GUIDE Top Discharge Ball Valve Unit

Available from
Warren Rupp

- ① Surge Suppressor
- ② 020-051-000 Filter/Regulator
- ③ Air Dryer

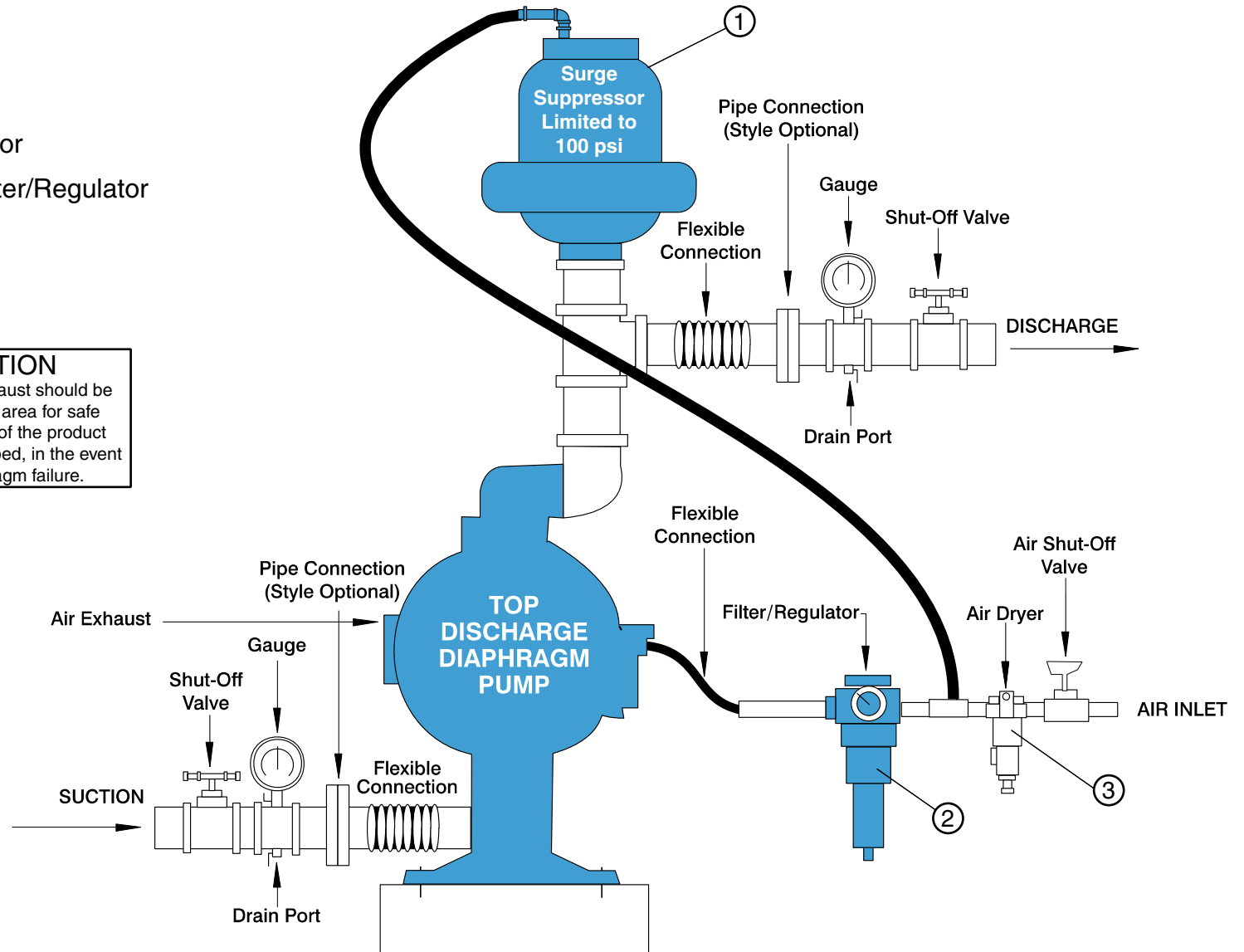
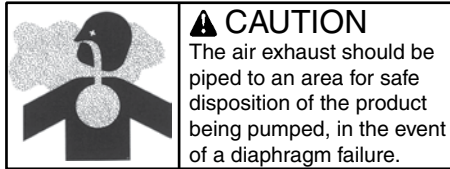

MATERIAL CODES

THE LAST 3 DIGITS OF PART NUMBER

000	Assembly, sub-assembly; and some purchased items	306	Carbon Steel, Black PTFE Coated	374	Carboxylated Nitrile	604	PTFE
010	Cast Iron	307	Aluminum, Black Epoxy Coated	375	Fluorinated Nitrile	606	PTFE
012	Powered Metal	308	Stainless Steel, Black PTFE Coated	378	High Density Polypropylene	607	Envelon
015	Ductile Iron	309	Aluminum, Black PTFE Coated	379	Conductive Nitrile	608	Conductive PTFE
020	Ferritic Malleable Iron	310	PVDF Coated	405	Cellulose Fibre	610	PTFE Encapsulated Silicon
025	Music Wire	313	Aluminum, White Epoxy Coated	408	Cork and Neoprene	611	PTFE Encapsulated FKM
080	Carbon Steel, AISI B-1112	330	Zinc Plated Steel	425	Compressed Fibre	632	Neoprene/Hytrel
100	Alloy 20	331	Chrome Plated Steel	426	Blue Gard	633	FKM/PTFE
110	Alloy Type 316 Stainless Steel	332	Aluminum, Electroless Nickel Plated	440	Vegetable Fibre	634	EPDM/PTFE
111	Alloy Type 316 Stainless Steel (Electro Polished)	333	Carbon Steel, Electroless Nickel Plated	465	Fibre	635	Neoprene/PTFE
112	Alloy C	335	Galvanized Steel	500	Delrin 500	637	PTFE, FKM/PTFE
113	Alloy Type 316 Stainless Steel (Hand Polished)	336	Zinc Plated Yellow Brass	501	Delrin 570	638	PTFE, Hytrel/PTFE
114	303 Stainless Steel	337	Silver Plated Steel	502	Conductive Acetal, ESD-800	639	Nitrile/TFE
115	302/304 Stainless Steel	340	Nickel Plated	503	Conductive Acetal, Glass-Filled	643	Santoprene®/EPDM
117	440-C Stainless Steel (Martensitic)	342	Filled Nylon	505	Acrylic Resin Plastic	644	Santoprene®/PTFE
120	416 Stainless Steel (Wrought Martensitic)	351	Food Grade Santoprene	506	Delrin 150	656	Santoprene Diaphragm and Check Balls/EPDM Seats
123	410 Stainless Steel (Wrought Martensitic)	353	Geolast; Color: Black	520	Injection Molded PVDF Natural color	661	EPDM/Santoprene
148	Hardcoat Anodized Aluminum	354	Injection Molded #203-40 Santoprene- Duro 40D +/-5; Color: RED	540	Nylon	666	FDA Nitrile Diaphragm, PTFE Overlay, Balls, and Seals
149	2024-T4 Aluminum	355	Thermal Plastic	541	Nylon	668	PTFE, FDA Santoprene/PTFE
150	6061-T6 Aluminum	356	Hytrel	542	Nylon		
151	6063-T6 Aluminum	357	Injection Molded Polyurethane	544	Nylon Injection Molded		Delrin and Hytrel are registered tradenames of E.I. DuPont.
152	2024-T4 Aluminum (2023-T351)	358	Urethane Rubber (Some Applications) (Compression Mold)	550	Polyethylene		Gylon is a registered tradename of Garlock, Inc.
154	Almag 35 Aluminum	359	Urethane Rubber	551	Glass Filled Polypropylene		Nylatron is a registered tradename of Polymer Corp.
155	356-T6 Aluminum	360	Nitrile Rubber Color coded: RED	552	Unfilled Polypropylene		Santoprene is a registered tradename of Exxon Mobil Corp.
156	356-T6 Aluminum	361	Nitrile	553	Unfilled Polypropylene		Rulon II is a registered tradename of Dixon Industries Corp.
157	Die Cast Aluminum Alloy #380	363	FKM (Fluorocarbon). Color coded: YELLOW	555	Polyvinyl Chloride		Ryton is a registered tradename of Phillips Chemical Co.
158	Aluminum Alloy SR-319	364	E.P.D.M. Rubber. Color coded: BLUE	556	Black Vinyl		Valox is a registered tradename of General Electric Co.
159	Anodized Aluminum	365	Neoprene Rubber. Color coded: GREEN	557	Conductive Polypropylene		PortaPump, Tranquilizer and SludgeMaster are registered tradenames of Warren Rupp, Inc.
162	Brass, Yellow, Screw Machine Stock	366	Food Grade Nitrile	558	Conductive HDPE		
165	Cast Bronze, 85-5-5-5	368	Food Grade EPDM	559	Glass-Filled Conductive Polypropylene		
166	Bronze, SAE 660	370	Butyl Rubber Color coded: BROWN	570	Rulon II		
170	Bronze, Bearing Type, Oil Impregnated	371	Phlthane (Tuftane)	580	Ryton		
175	Die Cast Zinc			590	Valox		
180	Copper Alloy			591	Nylatron G-S		
305	Carbon Steel, Black Epoxy Coated			592	Nylatron NSB		
				600	PTFE (virgin material) Tetrafluorocarbon (TFE)		
				601	PTFE (Bronze and moly filled)		
				602	Filled PTFE		
				603	Blue Gylon		

TROUBLESHOOTING

Possible Symptoms:

- Pump will not cycle.
- Pump cycles, but produces no flow.
- Pump cycles, but flow rate is unsatisfactory.
- Pump cycle seems unbalanced.
- Pump cycle seems to produce excessive vibration.

What to Check: Excessive suction lift in system.

Corrective Action: For lifts exceeding 20 feet (6 meters), filling the pumping chambers with liquid will prime the pump in most cases.

What to Check: Excessive flooded suction in system.

Corrective Action: For flooded conditions exceeding 10 feet (3 meters) of liquid, install a back pressure device.

What to Check: System head exceeds air supply pressure.

Corrective Action: Increase the inlet air pressure to the pump. Most diaphragm pumps are designed for 1:1 pressure ratio at zero flow.

What to Check: Air supply pressure or volume exceeds system head.

Corrective Action: Decrease inlet air pressure and volume to the pump as calculated on the published PERFORMANCE CURVE. Pump is cavitating the fluid by fast cycling.

What to Check: Undersized suction line.

Corrective Action: Meet or exceed pump connection recommendations shown on the DIMENSIONAL DRAWING.

What to Check: Restricted or undersized air line.

Corrective Action: Install a larger air line and connection. Refer to air inlet recommendations shown in your pump's SERVICE MANUAL.

What to Check: Check ESADS+Plus, the Externally Serviceable Air Distribution System of the pump.

Corrective Action: Disassemble and inspect the main air distribution valve, pilot valve and pilot valve actuators. Refer to the parts drawing and air valve section of the SERVICE MANUAL. Check for clogged discharge or closed valve before reassembly.

What to Check: Rigid pipe connections to pump.

Corrective Action: Install flexible connectors and a surge suppressor.

What to Check: Blocked air exhaust muffler.

Corrective Action: Remove muffler screen, clean or de-ice and reinstall. Refer to the Air Exhaust section of your pump SERVICE MANUAL.

What to Check: Pumped fluid in air exhaust muffler.

Corrective Action: Disassemble pump chambers. Inspect for diaphragm rupture or loose diaphragm plate assembly. Refer to the Diaphragm Replacement section of your pump SERVICE MANUAL.

What to Check: Suction side air leakage or air in product.

Corrective Action: Visually inspect all suction side gaskets and pipe connections.

What to Check: Obstructed check valve.

Corrective Action: Disassemble the wet end of the pump and manually dislodge obstruction in the check valve pocket. Refer to the Check Valve section of the pump SERVICE MANUAL for disassembly instructions.

What to Check: Worn or misaligned check valve or check valve seat.

Corrective Action: Inspect check valves and seats for wear and proper seating. Replace if necessary. Refer to Check Valve section of the pump SERVICE MANUAL for disassembly instructions.

What to Check: Blocked suction line.

Corrective Action: Remove or flush obstruction. Check and clear all suction screens and strainers.

What to Check: Blocked discharge line.

Corrective Action: Check for obstruction or closed discharge line valves.

What to Check: Blocked pumping chamber.

Corrective Action: Disassemble and inspect the wetted chambers of the pump. Remove or flush any obstructions. Refer to the pump SERVICE MANUAL for disassembly instructions.

What to Check: Entrained air or vapor lock in one or both pumping chambers.

Corrective Action: Purge chambers through tapped chamber vent plugs. PURGING THE CHAMBERS OF AIR CAN BE DANGEROUS! Contact the Warren Rupp Technical Services Department before performing this procedure. A model with top-ported discharge will reduce or eliminate problems with entrained air.

If your pump continues to perform below your expectations, contact your local Warren Rupp Distributor or factory Technical Services Group for a service evaluation.

WARRANTY

Refer to the enclosed Warren Rupp Warranty Certificate.

Composite Repair Parts Drawing

AVAILABLE SERVICE AND CONVERSION KITS

476-176-000 AIR END KIT

Seals, O-rings, Gaskets, Retaining Rings, Air Valve Sleeve & Spool Set and Pilot Valve Assembly.

476-177-000* AIR END KIT (for Stroke Indicator Option)

Seals, O-rings, Gaskets, Retaining Rings, Air Valve Sleeve & Spool Set and Pilot Valve Assembly.

476-140-354 WETTED END KIT

Santoprene Diaphragms, Santoprene Balls and TFE Seals.

476-140-654 WETTED END KIT

Santoprene Diaphragms, PTFE Overlay Diaphragms, TFE Balls and TFE Seals.

476-143-354 WETTED END KIT (for Polypropylene Spill Containment)

Santoprene Diaphragms, PTFE Overlay Diaphragms, PTFE Pumping Diaphragms, PTFE Balls and PTFE Seals.

476-143-655 WETTED END KIT (for PVDF Spill Containment)

Santoprene Diaphragms, PTFE Overlay Diaphragms, PTFE Pumping Diaphragms, PTFE Balls and PTFE Seals.

HARDWARE KITS

475-173-308 PTFE Coated Stainless Steel Capscrews, Hex Nuts, Washers and Support Rod

475-174-308 (For use with Spill Containment Options)

ELECTRONIC LEAK DETECTOR KITS

032-037-000 100VAC 50Hz
or 110-120VAC 50-60Hz
or 220-240VAC 50-60Hz

032-045-000 12-32VDC

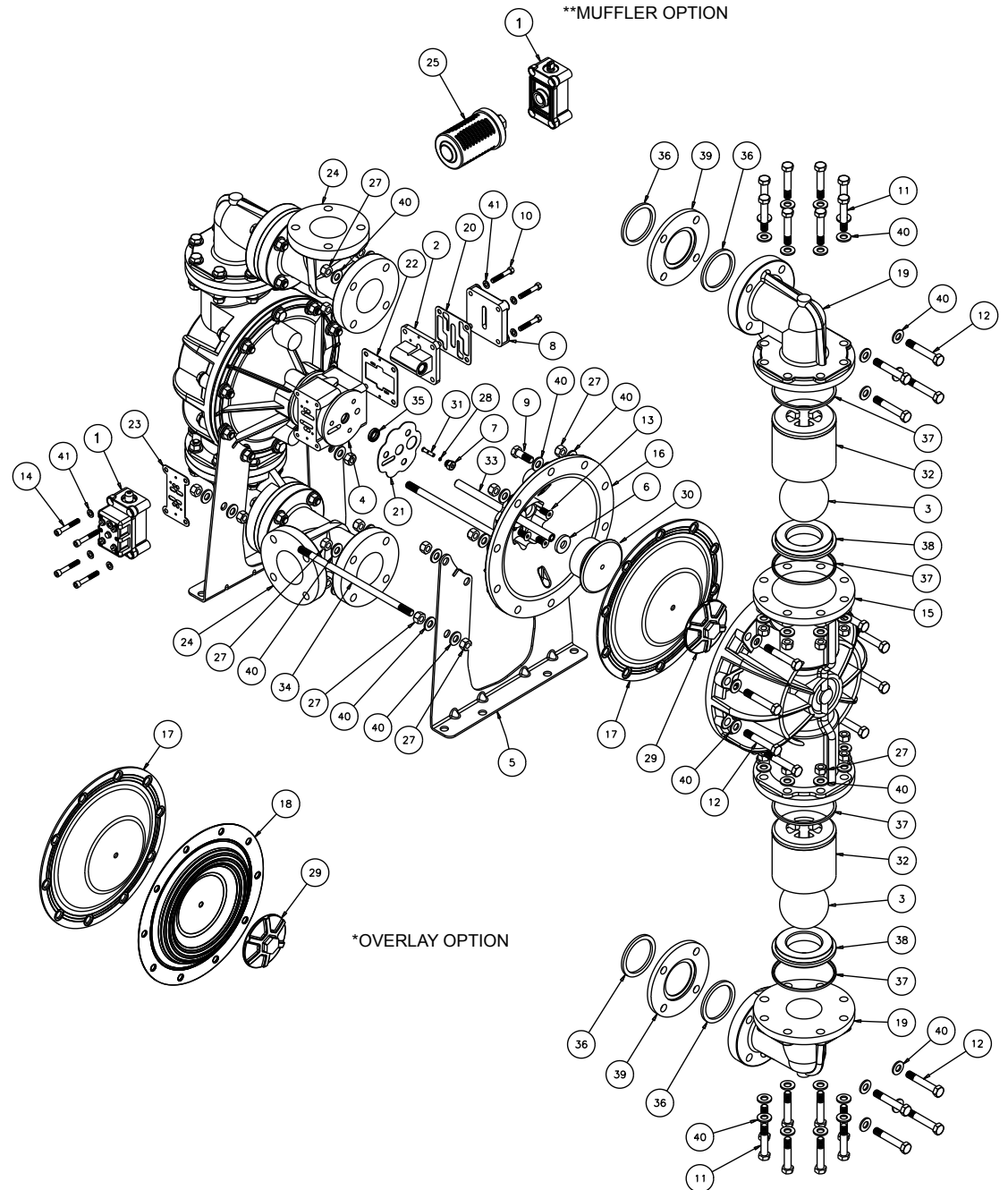

Spill Containment Option for Virgin PTFE Equipped Pumps Drawing

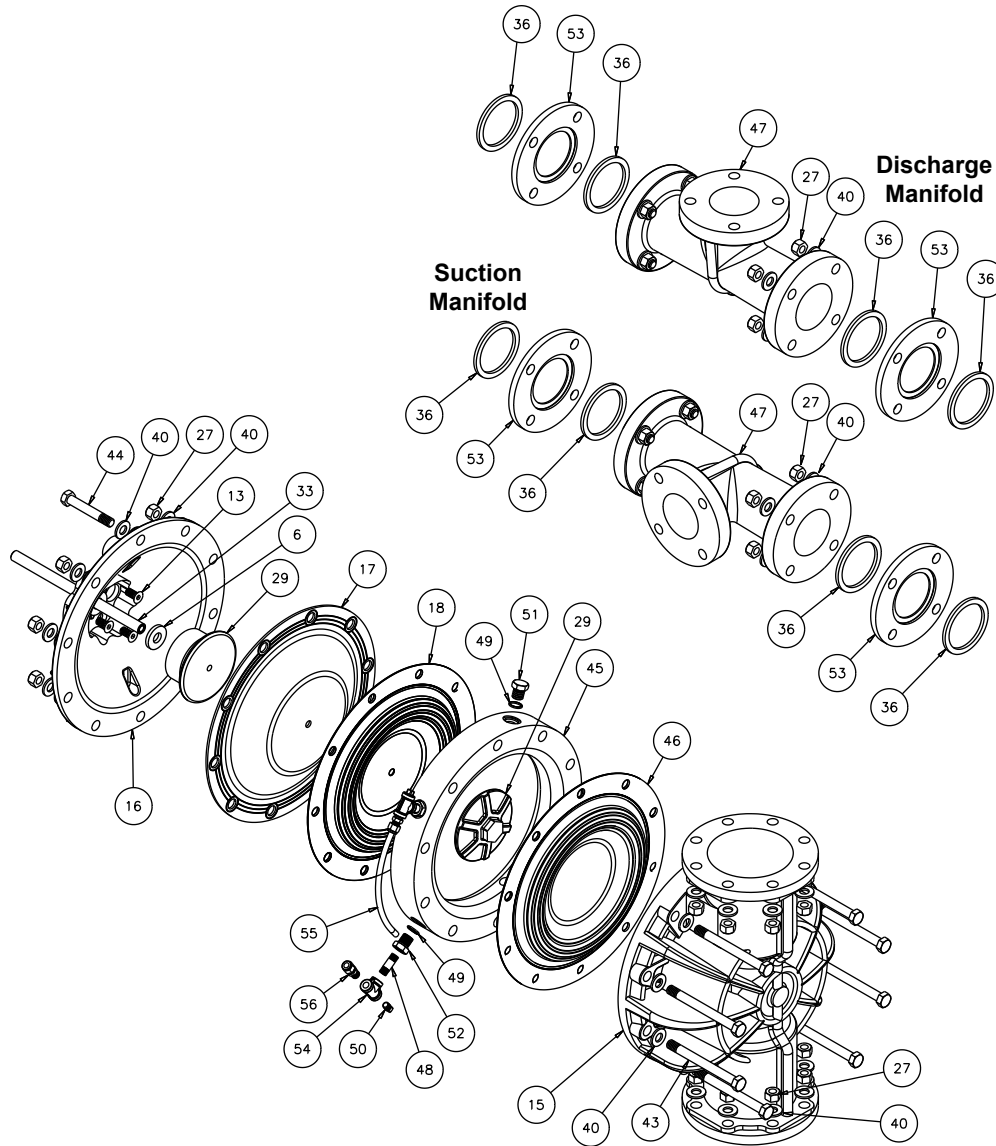

S30 SPILL CONTAINMENT REPAIR PARTS LIST FOR VIRGIN PTFE EQUIPPED PUMPS

ITEM	PART NUMBER	DESCRIPTION	QTY
1	031-146-000	Air Valve Assembly (replaces 031-140-000)	1
	031-147-000	Air Valve Assembly (replaces 031-141-000)	1
43	170-113-115	Capscrew, Hex HD 5/8-11 x 6.00	16
	170-113-308	Capscrew, Hex HD 5/8-11 x 6.00	16
44	170-115-115	Capscrew, Hex HD 5/8-11 x 4.00	4
	170-115-308	Capscrew, Hex HD 5/8-11 x 4.00	4
45	196-156-552	Chamber, Spill Containment	2
	196-156-600	Chamber, Spill Containment	2
46	286-079-600	Diaphragm, Pumping	2
47	518-135-520	Manifold	2
	518-135-520E	Manifold, 80mm DIN	2
	518-135-552	Manifold	2
	518-135-552E	Manifold, 80mm DIN	2
48	538-022-110	Nipple, Pipe	4
	538-022-308	Nipple, Pipe	4
49	560-078-611	O-Ring	8
50	618-003-110	Plug, Pipe	4
	618-003-308	Plug, Pipe	4
51	618-025-110	Plug, Boss	4
	618-025-308	Plug, Boss	4
52	618-031-110	Plug, Boss	4
	618-031-308	Plug, Boss	4
53	770-061-600	Spacer, Manifold	4
	770-061-552	Spacer, Manifold	4
54	835-005-110	Tee, Pipe	4
	835-005-308	Tee, Pipe	4
55	860-057-606	Tube, Sight	2
56	866-060-110	Connector, Tube	4

SPILL CONTAINMENT FOR PTFE EQUIPPED PUMPS CONCEPT

The Spill Containment option prevents the air end components from being contaminated or damaged when a pumping diaphragm ruptures while pumping caustic or toxic materials. It also helps to protect the environment. With the installation of optional leak detectors (either mechanical or electronic) the diaphragm rupture can be detected. The pump can then be shut down and repaired before any caustic or toxic materials can enter the air end and be exhausted into the surrounding environment.

SPILL CONTAINMENT OPTION DIAPHRAGM SERVICING

To service the diaphragms first shut off the suction, then shut off the discharge lines to the pump. Next shut off the compressed air supply, bleed the pressure from the pump, and disconnect the air supply line from the pump. Drain any remaining pumped liquid from the pump. Remove the pump before servicing.

Next, drain the fluid from the Spill Containment chambers. This can be done by removing the bottom plug (item 50) from each Spill Containment chamber.

After the fluid from the Spill Containment chambers has been drained, the wet end components can now be removed. See diaphragm servicing section for detailed instructions. The Spill Containment option has two additional virgin PTFE pumping diaphragms (item 46).

FILLING SPILL CONTAINMENT CHAMBERS WITH LIQUID

THE CHAMBERS ARE FILLED WITH WATER AT THE FACTORY.

If you prefer to substitute another liquid, to prevent system contamination consult the factory first to determine compatibility of the substitute with pump construction.

Follow the steps listed here to replace the liquid in the pump after disassembly or liquid loss:

1. Drain the fluid in the Spill Containment chambers by removing the bottom two boss plugs (items 50). Replace the bottom two boss plugs after the fluid is drained.

2. Remove the eight capscrews (item 11) fastening the discharge manifold and elbows to the outer chambers (items 15). The discharge manifolds and elbows can now be removed.

3. Remove the top two boss plugs (items 50). The Spill Containment chambers are filled through the exposed ports.

4. Apply air pressure to the air distribution valve. Install safety clip (item 1-F) into the smaller unthreaded hole in one end cap. This locks the valve spool to one side, keeping the pump from shifting.

5. Face the side of the pump with the installed safety clip. If the safety clip is installed in the top end cap, fill the left spill containment chamber. If the safety clip is installed on the bottom end cap, fill the right Spill Containment chamber. The volume of fluid is 3770 ml (127.5 fl. oz.). It is important that

the exact amount of fluid is used. Too little or too much fluid causes premature diaphragm failure and erratic pumping.

6. Loosely reinstall one boss plug to the filled Spill Containment chamber.

7. Shut off air supply. Remove safety clip. Adjust the air line regulator so that air pressure slowly fills the pump. The diaphragm expands, forcing the fluid in the chamber to be slowly displaced. When the pump shifts to the opposite side, quickly install the safety clip.

8. Loosen the top boss plug on the filled chambers. This allows fluid in the chamber to purge trapped air from the chamber. This can be seen by watching the column of fluid in the sight tube. When fluid appears at the top of the port, quickly tighten the boss plug. Fluid loss of 1 to 2ml is acceptable.

9. Tilt the pump so the uppermost pipe tee (item 53) is in the vertical position. Loosen the pipe plug (item 49). This will allow trapped air to purge through the pipe tee. When fluid appears at the tee opening, reinstall the pipe plug.

NOTE: If all air is not purged using this procedure, remove the check valve components from the top port of the outer chamber (item 15). Apply manual pressure to the pumping diaphragm by inserting a blunt instrument into the top port of the outer chamber and applying pressure to the diaphragm. Loosen the pipe plug (item 49) allowing the fluid to purge any remaining trapped air. Reinstall the plug.

10. Repeat steps 5 through 9 to fill opposite Spill Containment chamber.

11. Reinstall the check valve components, discharge manifold and elbows to the pump. The pump is now ready for operation.



! IMPORTANT

Read these instructions completely, before installation and start-up. It is the responsibility of the purchaser to retain

this manual for reference. Failure to comply with the recommendations stated in this manual will damage the pump, and void factory warranty.

Spill Containment Option for TPE Equipped Pumps Drawing

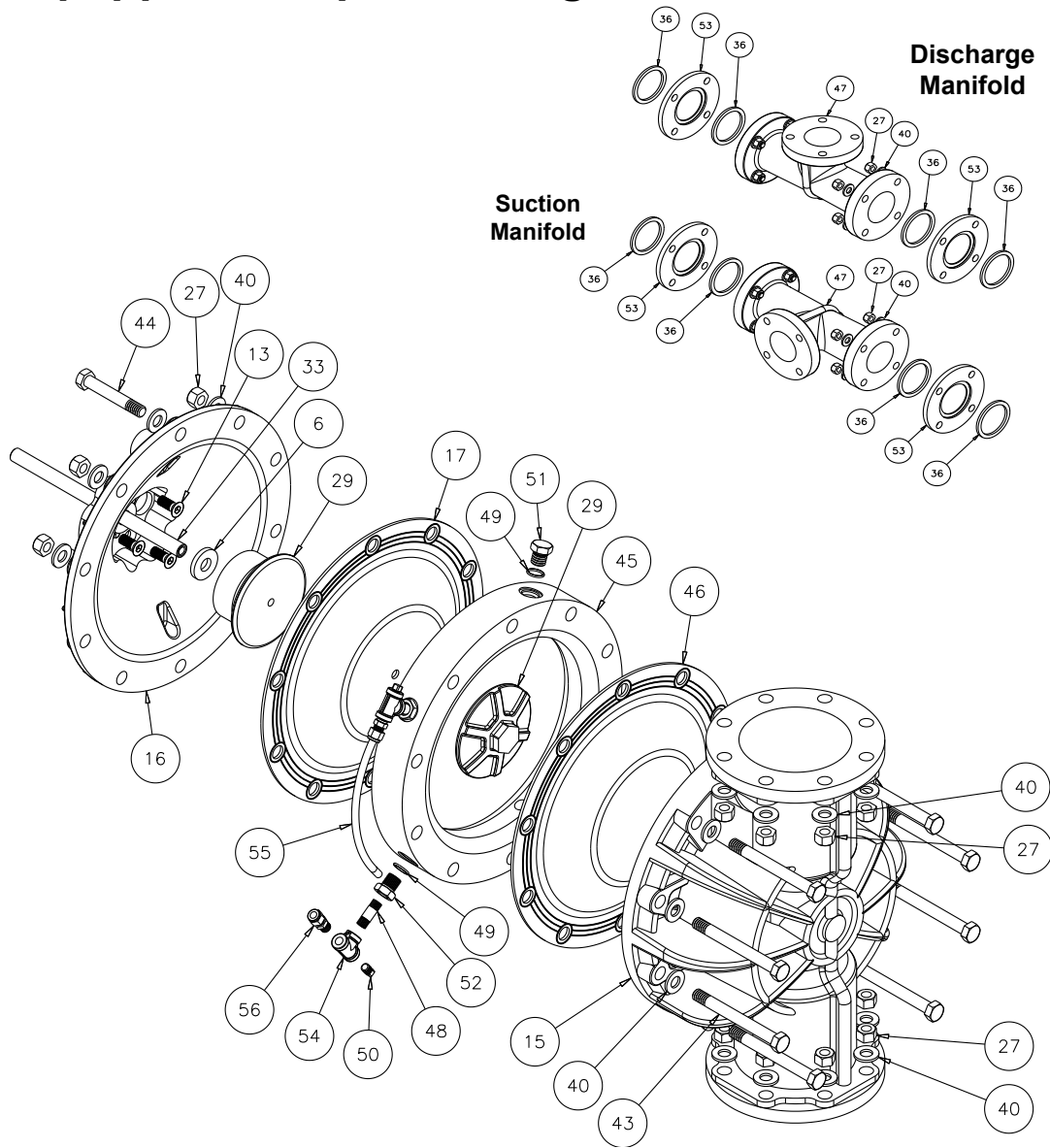

S30 SPILL CONTAINMENT FOR TPE EQUIPPED PUMPS REPAIR PARTS LIST

ITEM	PART NUMBER	DESCRIPTION	QTY
1	031-146-000	Air Valve Assembly (replaces 031-140-000)	1
	031-147-000	Air Valve Assembly (replaces 031-141-000)	1
43	170-113-115	Capscrew, Hex HD 5/8-11 x 6.00	16
	170-113-308	Capscrew, Hex HD 5/8-11 x 6.00	16
44	170-115-115	Capscrew, Hex HD 5/8-11 x 4.00	4
	170-115-308	Capscrew, Hex HD 5/8-11 x 4.00	4
45	196-156-552	Chamber, Spill Containment	2
	196-156-600	Chamber, Spill Containment	2
46	286-080-354	Diaphragm, Pumping	2
47	518-135-520	Manifold, Spill Containment	2
	518-135-520E	Manifold, 80mm DIN	2
	518-135-552	Manifold, Spill Containment	2
	518-135-552E	Manifold, 80mm DIN	2
48	538-022-110	Pipe, Nipple	4
	538-022-308	Pipe, Nipple	4
49	560-078-611	O-ring	8
50	618-003-110	Plug, Pipe	4
	618-003-308	Plug, Pipe	4
51	618-025-110	Plug, Boss	4
	618-025-308	Plug, Boss	4
52	618-031-110	Plug, Boss	4
	618-031-308	Plug, Boss	4
53	770-061-600	Spacer, Manifold	4
	770-061-552	Spacer, Manifold	4
54	835-005-110	Tee, Pipe	4
	835-005-308	Tee, Pipe	4
55	860-057-606	Tube, Sight	2
56	866-060-110	Connector, Tube	4

SPILL CONTAINMENT FOR TPE EQUIPPED PUMPS CONCEPT

The Spill Containment option prevents the air end components from being contaminated or damaged when a pumping diaphragm ruptures while pumping caustic or toxic materials. It also helps to protect the environment. With the installation of optional leak detectors (either mechanical or electronic) the diaphragm rupture can be detected. The pump can then be shut down and repaired before any caustic or toxic materials can enter the air end and be exhausted into the surrounding environment.

SPILL CONTAINMENT OPTION DIAPHRAGM SERVICING

To service the diaphragms first shut off the suction, then shut off the discharge lines to the pump. Next shut off the compressed air supply, bleed the pressure from the pump, and disconnect the air supply line from the pump. Drain any remaining pumped liquid from the pump. Remove the pump before servicing.

Next, drain the fluid from the Spill Containment chambers. This can be done by removing the bottom plug (item 50) from each Spill Containment chamber.

After the fluid from the Spill Containment chambers has been drained, the wet end components can now be removed. See diaphragm servicing section for detailed instructions. The Spill Containment option has two additional TPE pumping diaphragms (item 46).

FILLING SPILL CONTAINMENT CHAMBERS WITH LIQUID

THE CHAMBERS ARE FILLED WITH WATER AT THE FACTORY.

If you prefer to substitute another liquid, to prevent system contamination consult the factory first to determine compatibility of the substitute with pump construction.

Follow the steps listed here to replace the liquid in the pump after disassembly or liquid loss:

1. Drain the fluid in the Spill Containment chambers by removing the bottom two boss plugs (items 50). Replace the bottom two boss plugs after the fluid is drained.

2. Remove the eight capscrews (item 11) fastening the discharge manifold and elbows to the outer chambers (items 15). The discharge manifolds and elbows can now be removed.

3. Remove the top two boss plugs (items 50). The Spill Containment chambers are filled through the exposed ports.

4. Apply air pressure to the air distribution valve. Install safety clip (item 1-F) into the smaller unthreaded hole in one end cap. This locks the valve spool to one side, keeping the pump from shifting.

5. Face the side of the pump with the installed safety clip. If the safety clip is installed in the top end cap, fill the left Spill Containment chamber. If the safety clip is installed on the bottom end cap, fill the right Spill Containment chamber. The volume of fluid is 3770 ml (127.5 fl. oz.). It is important that the

exact amount of fluid is used. Too little or too much fluid causes premature diaphragm failure and erratic pumping.

6. Loosely reinstall one boss plug to the filled Spill Containment chamber.

7. Shut off air supply. Remove safety clip. Adjust the air line regulator so that air pressure slowly fills the pump. The diaphragm expands, forcing the fluid in the chamber to be slowly displaced. When the pump shifts to the opposite side, quickly install the safety clip.

8. Loosen the top boss plug on the filled chambers. This allows fluid in the chamber to purge trapped air from the chamber. This can be seen by watching the column of fluid in the sight tube. When fluid appears at the top of the port, quickly tighten the boss plug. Fluid loss of 1 to 2ml is acceptable.

9. Tilt the pump so the uppermost pipe tee (item 53) is in the vertical position. Loosen the pipe plug (item 49). This will allow trapped air to purge through the pipe tee. When fluid appears at the tee opening, reinstall the pipe plug.

NOTE: If all air is not purged using this procedure, remove the check valve components from the top port of the outer chamber (item 15). Apply manual pressure to the pumping diaphragm by inserting a blunt instrument into the top port of the outer chamber and applying pressure to the diaphragm. Loosen the pipe plug (item 49) allowing the fluid to purge any remaining trapped air. Reinstall the plug.

10. Repeat steps 5 through 9 to fill opposite Spill Containment chamber.

11. Reinstall the check valve components, discharge manifold and elbows to the pump. The pump is now ready for operation.



! IMPORTANT

Read these instructions completely, before installation and start-up. It is the responsibility of the purchaser to retain this manual for reference. Failure to comply with the recommendations stated in this manual will damage the pump, and void factory warranty.

Air Distribution Valve Assembly Drawing

S30 Design Level 2

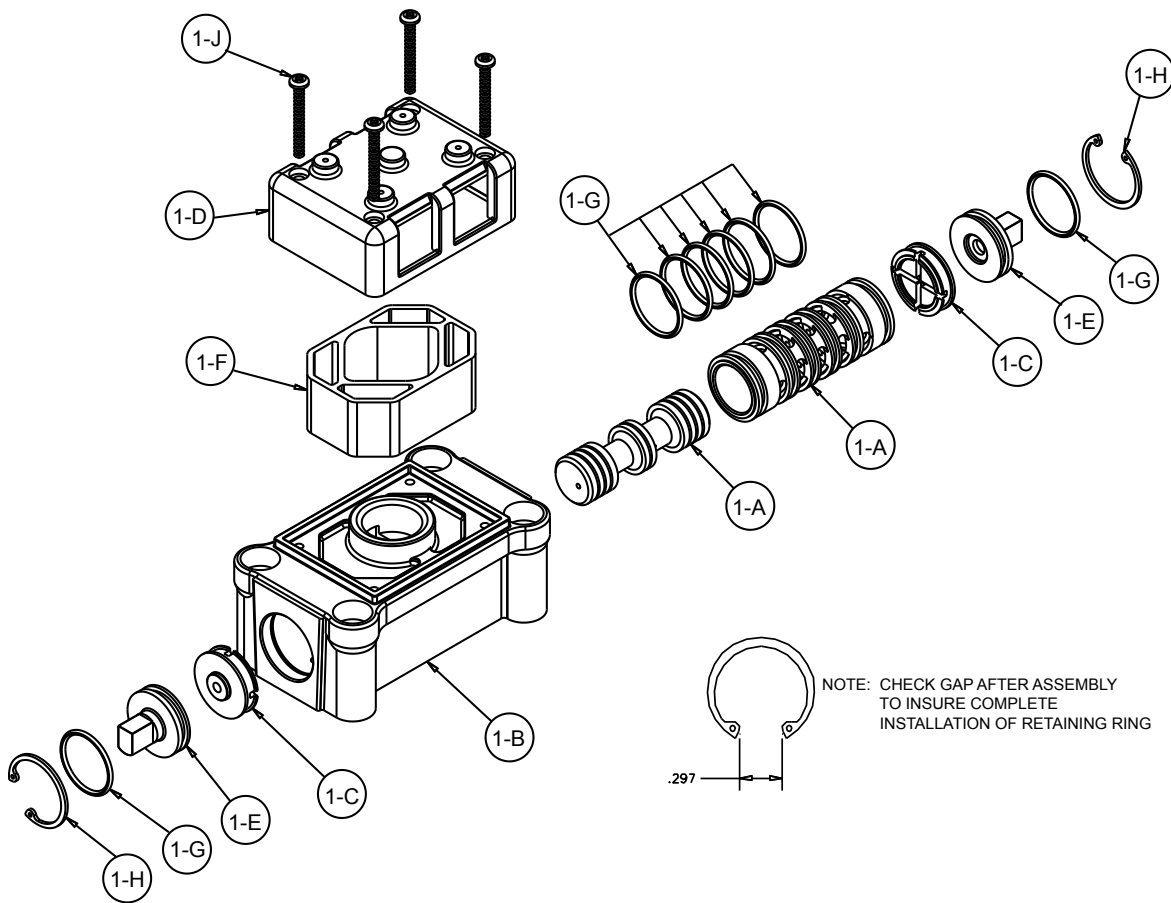

MAIN AIR VALVE ASSEMBLY PARTS LIST

ITEM	PART NUMBER	DESCRIPTION	QTY
1	031-140-000	Main Air Valve Assembly	1
1-A	031-139-000	Spool Assembly	1
1-B	095-094-551	Body, Air Valve	1
1-C	132-029-552	Bumper	2
1-D	165-096-551	Cap, Muffler	1
1-E	165-115-552	Cap, End	2
1-F	530-028-550	Muffler	1
1-G	560-020-360	O-Ring	8
1-H	675-044-115	Ring, Retaining	2
1-J	710-015-115	Screw, Self-tapping	4

For pumps equipped with PTFE Coated Hardware

1	031-140-002	Air Valve Assembly	1
(Includes all items used on 031-140-000 except:)			
1-J	710-015-308	Screw Self tapping	4
1-H	675-044-308	Ring, Retaining	2

For pumps equipped with PTFE coated hardware option:

1	031-141-000	Air Valve Assembly	1
(Includes all items used on 031-140-000 minus items 1-D, 1-F & 1-J)			

For pumps with alternate Mesh or Sound Dampening mufflers or piped exhaust:

1	031-041-002	Air Valve Assembly	1
(Includes all items used on 031-141-000 except:)			
1-H	675-044-308	Ring, Retaining	2

AIR DISTRIBUTION VALVE SERVICING

To service the air valve first shut off the compressed air, bleed the pressure from the pump, and disconnect the air supply line from the pump.

STEP #1: See Composite Repair and Parts Drawing.

Using a $\frac{5}{16}$ " Allen wrench, remove the four hex socket capscrews (item 14) and four flat washers (item 41). Remove the air valve assembly from the pump.

Remove and inspect gasket (item 23) for cracks or damage. Replace gasket if needed.

STEP #2: Disassembly of the air valve.

To access the internal air valve components first remove the two retaining rings (item 1-H) from each end of the air valve assembly using clip ring pliers.

Next remove the two end caps (item 1-E). Inspect the o-rings (item 1-G) for cuts or wear. Replace the o-rings if necessary.

Remove the two bumpers (item 1-C). Inspect the bumpers for cuts, wear or abrasion. Replace if necessary.

Remove the spool (part of item 1-A) from the sleeve. Be careful not to scratch or damage the outer diameter of the spool. Wipe spool with a soft cloth and inspect for scratches or wear.

Inspect the inner diameter of the sleeve (part of item 1-A) for dirt, scratches, or other contaminants. Remove the sleeve if needed and replace both the sleeve and spool with a new sleeve and spool set (item 1-A).

STEP #3: Reassembly of the air valve.

Install one end cap (item 1-E) with an o-ring (item 1-G) and one bumper (item 1-C) into one end of the air valve body (item 1-B). Install one retaining ring (item 1-H) into the groove on the same end.

Remove the new sleeve and spool set (item 1-A) from the plastic bag. Carefully remove the spool from the sleeve. Install the six o-rings (item 1-G) into the six grooves on the sleeve. Apply a light coating of grease to the o-rings before installing the sleeve into the valve body (item 1-B), align the slots in the sleeve with the slots in the valve body. Insert the spool into the sleeve. Be careful not to scratch or damage the spool during installation. Push the spool in until it touches the bumper on the opposite end.

Install the remaining bumper, end cap with o-ring, and retaining ring.

Fasten the air valve assembly (item 1) and gasket (item 23) to the pump.

Connect the compressed air line to the pump. The pump is now ready for operation.



! IMPORTANT

Read these instructions completely, before installation and start-up. It is the responsibility of the purchaser to retain this manual for reference. Failure to comply with the recommendations stated in this manual will damage the pump, and void factory warranty.

Air Valve Assembly Drawing with Stroke Indicator Option

S30 Design Level 2

Note: Stroke Indicator is standard on Spill Containment models

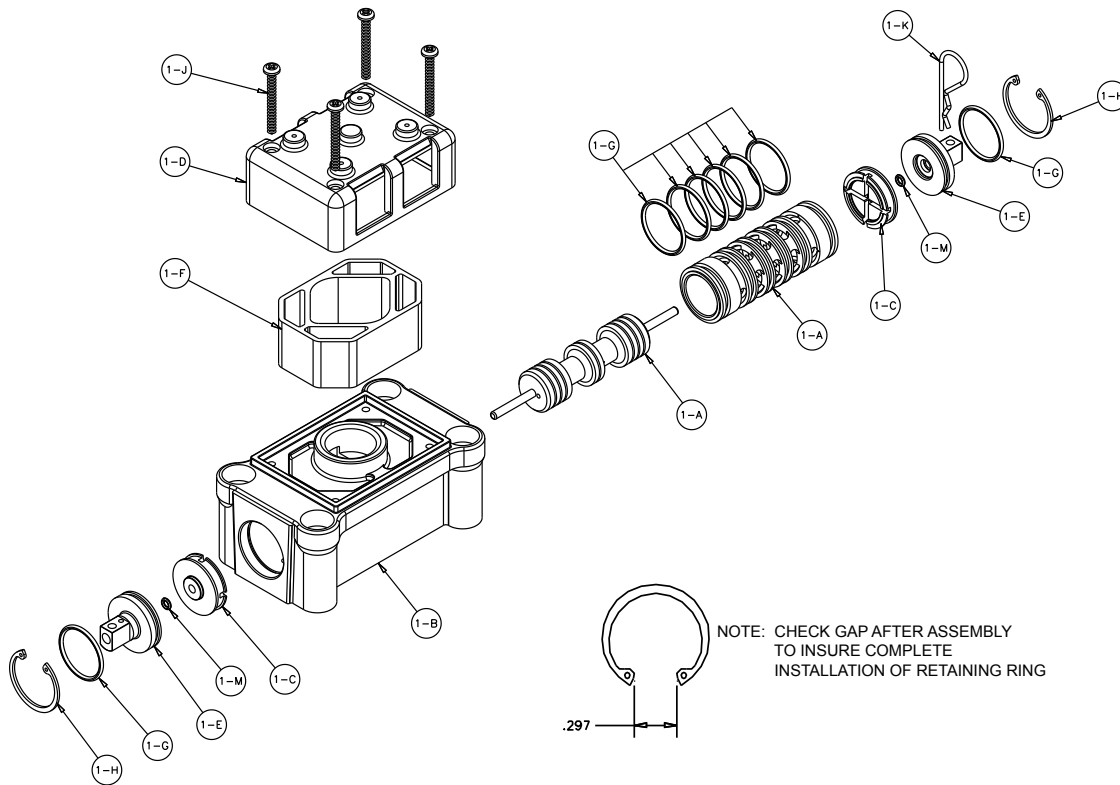

PILOT VALVE ASSEMBLY PARTS LIST

ITEM	PART NUMBER	DESCRIPTION	QTY
1	031-146-000	Air Valve Assembly	1
1-A	031-143-000	Sleeve and Spool Set w/Pins	1
1-B	095-094-551	Body, Air Valve	1
1-C	132-029-552	Bumper	2
1-D	165-096-551	Cap, Muffler	1
1-E	165-098-147	Cap, End	2
1-F	530-028-550	Muffler	1
1-G	560-020-360	O-Ring	8
1-H	675-044-115	Ring, Retaining	2
1-J	710-015-115	Screw, Self-Tapping	4
1-K	210-008-330	Clip, Safety	1
1-M	560-029-360	O-Ring	2

For Pumps with PTFE Coated Hardware:

1	031-146-002	Air Valve Assembly	1
1-J	710-015-308	Screw, Self Tapping	4
1-H	675-044-308	Ring, Retaining	2

(includes all other items on 031-146-000 above.)

For Pumps with Alternate Mesh, Sound Dampening Mufflers or Piped Exhaust:

1	031-147-000	Air Valve Assembly	1
---	-------------	--------------------	---

(includes all items on 031-146-000 minus 1-D, 1-F, & 1-J)

AIR DISTRIBUTION VALVE WITH STROKE INDICATOR OPTION SERVICING

To service the air valve first shut off the compressed air, bleed the pressure from the pump, and disconnect the air supply line from the pump.

STEP #1: See Composite Repair and Parts Drawing.

Using a $\frac{5}{16}$ " Allen wrench, remove the four hex socket capscrews (item 14) and four flat washers (item 41). Remove the air valve assembly from the pump.

Remove and inspect gasket (item 23) for cracks or damage. Replace gasket if needed.

STEP #2: Disassembly of the air valve.

To access the internal air valve components first remove the two retaining rings (item 1-H) from each end of the air valve assembly using clip ring pliers.

Next remove the two end caps (item 1-E). Inspect the o-rings (item 1-G) for cuts or wear. Replace the o-rings if necessary.

Remove the two bumpers (item 1-C). Inspect the bumper for cuts, wear or abrasions. Replace if necessary.

Remove the spool (part of item 1-C) from the sleeve. Be careful not to scratch or damage the outer diameter of the spool. Wipe spool with a soft cloth and inspect for scratches or wear.

Inspect the inner diameter of the sleeve (part of item 1-A) for dirt, scratches, or other contaminants. Remove the sleeve if needed and replace both the sleeve and spool with a new sleeve and spool set (item 1-A).

STEP #3: Reassembly of the air valve.

Install one bumper (item 1-C) and one end cap (item 1-E) with an o-ring (item 1-G) into one end of the air valve body (item 1-B). Install one retaining ring (item 1-H) into the groove on the same end. Insert the safety clip (item 1-K) through the small unthreaded hole in the end cap.

Remove the new sleeve and spool set (item 1-A) from the plastic bag. Carefully remove the spool from the sleeve. Install the six o-rings (item 1-G) into the six grooves on the sleeve. Apply a light coating of grease to the o-rings before installing the sleeve into the valve body (item 1-B), align the slots in the sleeve with the slots in the valve body. Insert the spool into the sleeve. Be careful not to scratch or damage the spool during installation. Push the spool in until the pin touches the safety clip on the opposite end.

Install the remaining bumper, end cap with o-ring, and retaining ring.

Fasten the air valve assembly (item 1) and gasket (item 23) to the pump.

Connect the compressed air line to the pump. The pump is now ready for operation.



! IMPORTANT

Read these instructions completely, before installation and start-up. It is the responsibility of the purchaser to retain this manual for reference. Failure to comply with the recommendations stated in this manual will damage the pump, and void factory warranty.

Solenoid Shifted Air Valve Drawing

SOLENOID SHIFTED AIR VALVE PARTS LIST

(Includes all items used on Composite Repair Parts List except as shown)

ITEM	PART NUMBER	DESCRIPTION	QTY
57	893-097-000	Solenoid Valve, NEMA4	1
58	219-001-000	Solenoid Coil, 24VDC	1
	219-004-000	Solenoid Coil, 24VAC/12VDC	1
	219-002-000	Solenoid Coil, 120VAC	1
	219-003-000	Solenoid Coil, 240VAC	1
59	241-001-000	Connector, conduit	1
60	170-061-115	Capscrew, Hex HD 3/8-16 x 1.75	4
61	618-052-506	Plug	2

For Explosion Proof Solenoid Valve

58	219-009-001	Solenoid Coil, 120VAC 60 Hz	1
	219-009-002	Solenoid Coil, 240VAC 60 HZ	1
	219-009-003	Solenoid Coil, 12VDC	1
	219-009-004	Solenoid Coil, 24VDC	1
	219-009-005	Solenoid Coil, 110VAC 50 Hz	1
	219-009-006	Solenoid Coil, 230VAC 50 Hz	1

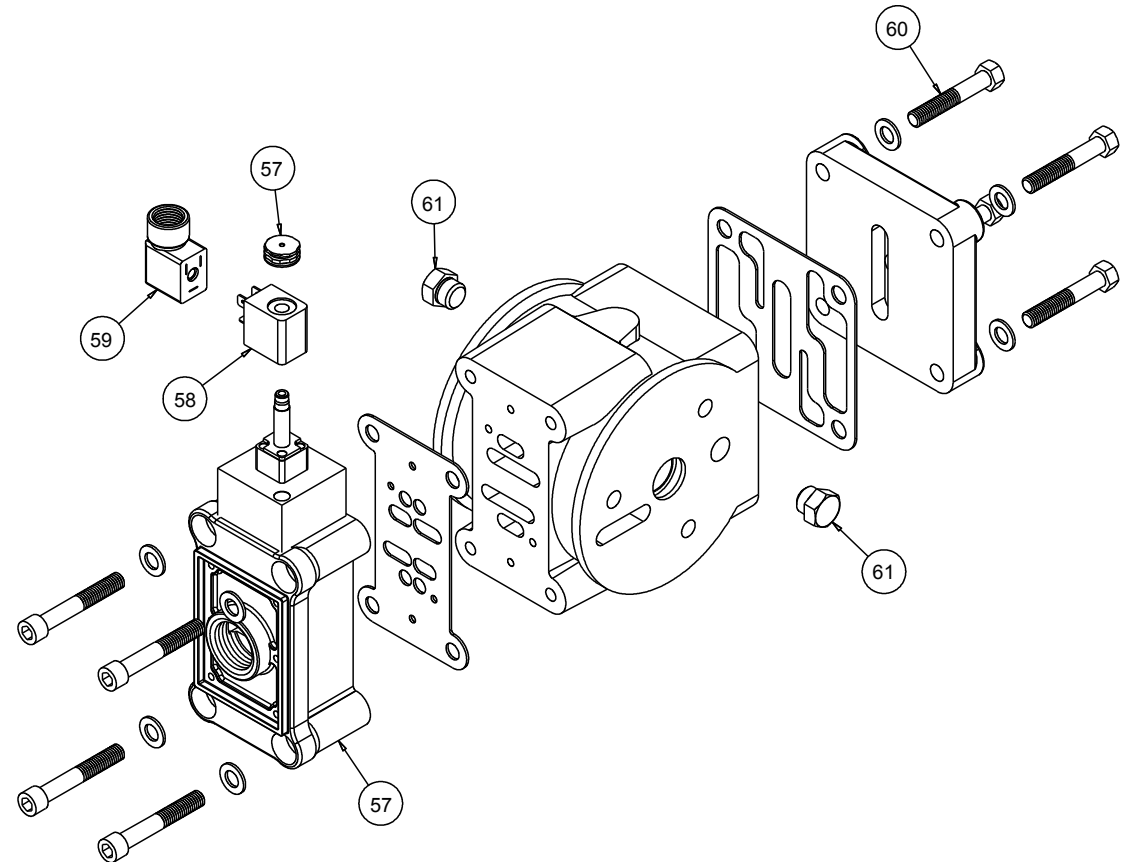

SOLENOID SHIFTED AIR DISTRIBUTION VALVE OPTION

Warren Rupp's solenoid shifted, air distribution valve option utilizes electrical signals to precisely control your SANDPIPER's speed. The solenoid coil is connected to a customer - supplied control. Compressed air provides the pumping power, while electrical signals control pump speed (pumping rate).

OPERATION

The Solenoid Shifted SANDPIPER has a solenoid operated, air distribution valve in place of the standard SANDPIPER's pilot operated, air distribution valve. Where a pilot valve is normally utilized to cycle the pump's air distribution valve, an electric solenoid is utilized. As the solenoid is powered, one of the pump's air chambers is pressurized while the other chamber is exhausted. When electric power is turned off, the solenoid shifts and the pressurized chamber is exhausted while the other chamber is pressurized. By alternately applying and removing power to the solenoid, the pump cycles much like a standard SANDPIPER pump, with one exception. This option provides a way to precisely control and monitor pump speed.

BEFORE INSTALLATION

Before wiring the solenoid, make certain it is compatible with your system voltage.

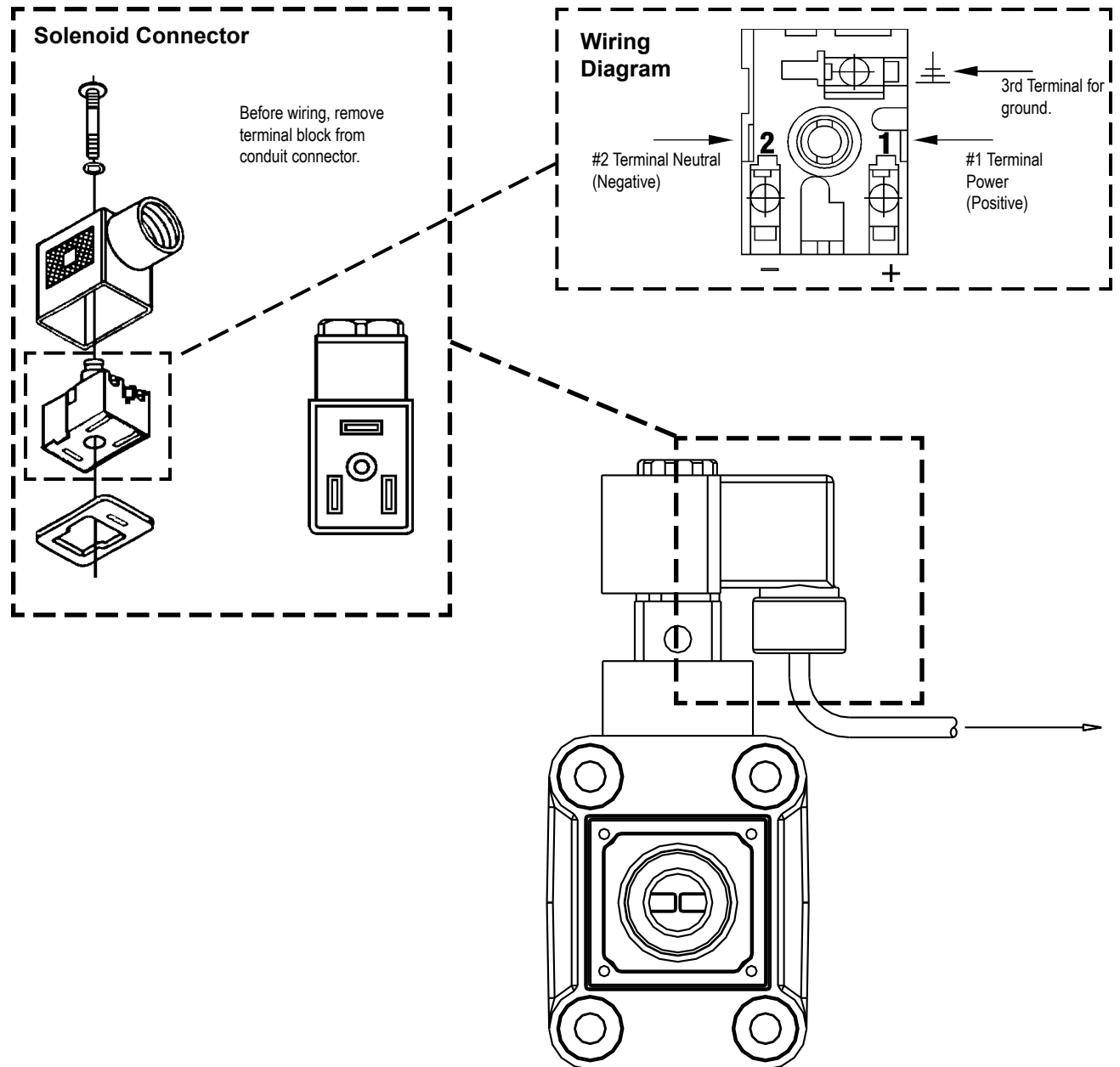

Pilot Valve Assembly Drawing

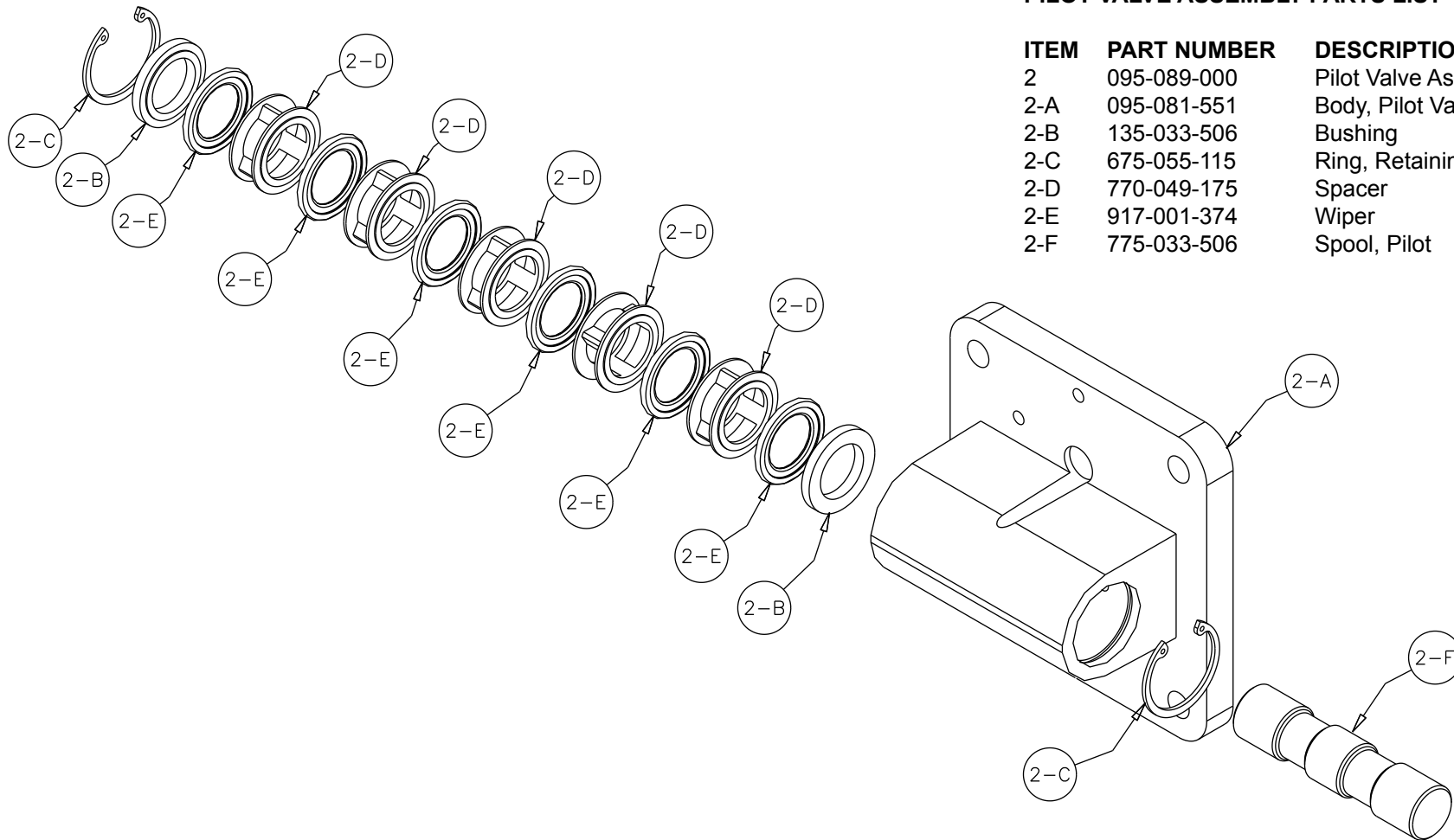

PILOT VALVE ASSEMBLY PARTS LIST

ITEM	PART NUMBER	DESCRIPTION	QTY
2	095-089-000	Pilot Valve Assembly	1
2-A	095-081-551	Body, Pilot Valve	1
2-B	135-033-506	Bushing	2
2-C	675-055-115	Ring, Retaining	2
2-D	770-049-175	Spacer	5
2-E	917-001-374	Wiper	6
2-F	775-033-506	Spool, Pilot	1

PILOT VALVE SERVICING

To service the pilot valve first shut off the compressed air supply, bleed the pressure from the pump, and disconnect the air supply line from the pump. Insert the safety clip (item 1-F from Air Distribution Valve assembly drawing) into the smaller unthreaded holes in the end cap (item 1-E from air distribution valve assembly drawing).

Step #1: See PUMP ASSEMBLY DRAWING.

Using a $\frac{9}{16}$ " wrench or socket, remove the four capscrews (items 10) and four flat washers (items 41). Remove the air inlet cap (item 8) and air inlet gasket (item 20). The pilot valve assembly (item 2) can now be removed for inspection or service.

Step #2: Disassembly of the pilot valve.

Remove the pilot valve spool (item 2-F). Wipe clean, and inspect for dirt, scratches or wear. Replace the spool if necessary.

Remove the two retaining rings (items 2-C) from each end of the pilot valve body using clip ring pliers.

Remove the two pilot valve bushings (items 2-B), five spacers (items 2-D), and six spool wipers (items 2-E) by pushing gently from other end of the pilot valve body. Inspect the wipers for cuts and/or wear. Replace any wipers as necessary.

Step #3: Re-assembly of the pilot valve.

First install a spiral retaining ring to one end of the pilot valve body. Install one bushing making sure the step side faces toward the wiper. Apply a light coating of grease to the outside diameter of each wiper. Next, gently push in the wipers and spacers until they are against the installed retaining ring in the opposite end of the pilot valve body. Install the remaining bushing making sure the step side faces the wiper. Install the remaining retaining ring using clip ring pliers.

Apply a light coating of grease to the inner diameter of each wiper. Also apply a light coating of grease to the outer diameter of the pilot valve spool and gently push the spool through each wiper.

Step #4: Inspect the actuator plungers.

See PUMP ASSEMBLY DRAWING. The actuator plungers (items 31) can be reached through the stem cavity of the pilot valve in the intermediate assembly (item 4).

Remove the plungers (items 31) from the bushings (item 7) in each end of the cavity. Inspect the installed o-ring (items 28) for cuts and/or wear. Replace the o-rings if necessary. Apply a light coating of grease to each o-ring and re-install the plungers in to the bushings. Push the plungers in as far as they will go.

Step #5: Re-install the pilot valve assembly into the intermediate assembly.

Be careful to align the ends of the stem between the plungers when inserting the stem of the pilot valve into the cavity of the intermediate.

Re-install the gasket (item 20), air inlet cap (item 8), capscrews and washers (items 10 and 39).

Connect the air supply to the pump. Remove the safety clip (item 1-F) from the end cap (item 1-E). The pump is now ready for operation.



! IMPORTANT

Read these instructions completely, before installation and start-up. It is the responsibility of the purchaser to retain this manual for reference. Failure to comply with the recommendations stated in this manual will damage the pump, and void factory warranty.

Diaphragm Service Drawing, Non-Overlay

Diaphragm Service Drawing, with Overlay

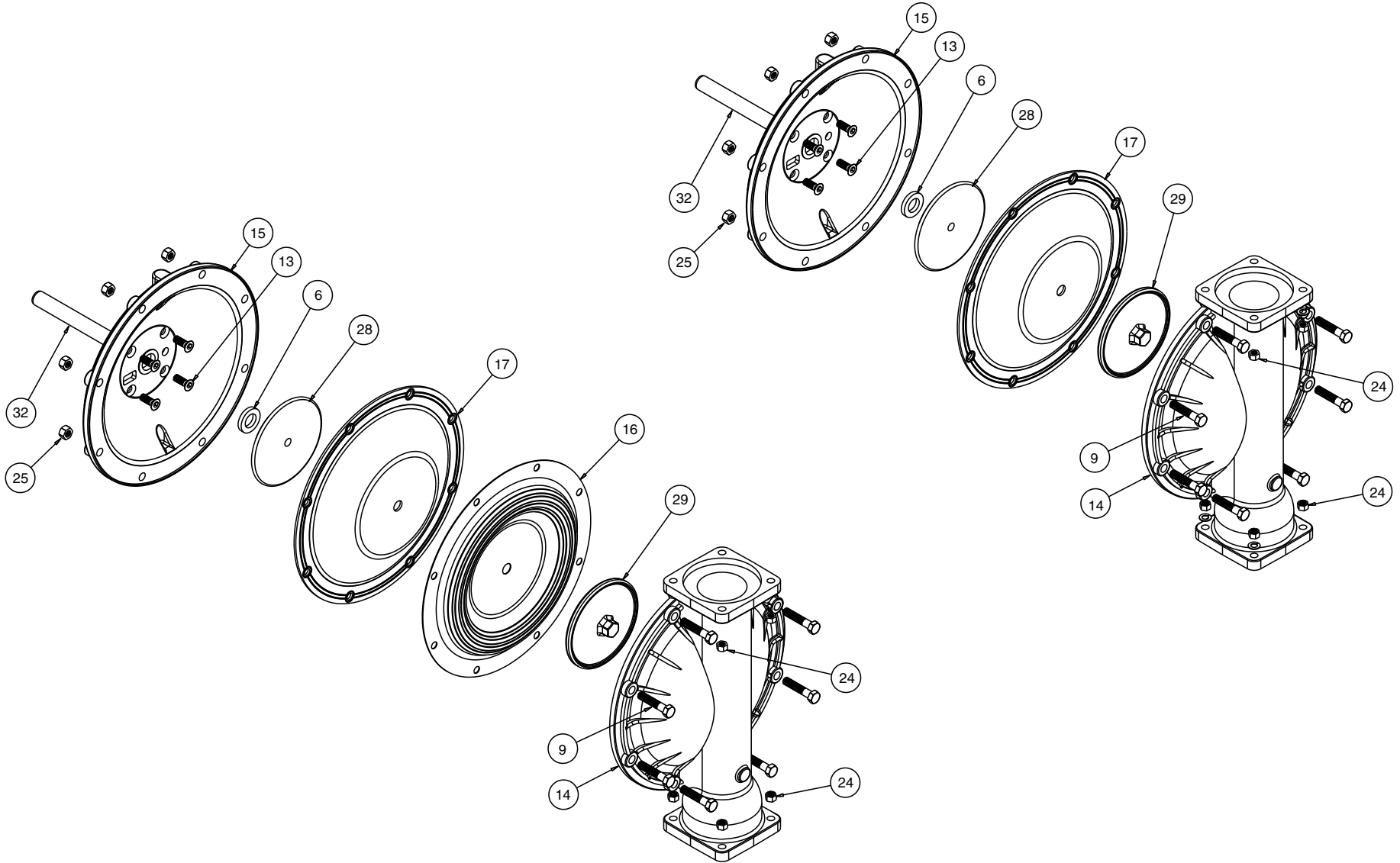

DIAPHRAGM SERVICING

To service the diaphragms first shut off the suction, then shut off the discharge lines to the pump. Shut off the compressed air supply, bleed the pressure from the pump, and disconnect the air supply line from the pump. Drain any remaining liquid from the pump.

Step #1: See the pump composite repair parts drawing, and the diaphragm servicing illustration.

Using a $\frac{9}{16}$ " wrench or socket, remove the 16 capscrews (items 11), hex nuts and washers that fasten the elbows (items 19) to the outer chambers (items 15). Remove the elbows with the manifolds and spacers attached.

Step #2: Removing the outer chambers.

Using a $\frac{9}{16}$ " wrench or socket, remove the 20 capscrews (items 9 & 12), hex nuts and washers that fasten the outer chambers, diaphragms, and inner chambers (items 16) together.

Step #3: Removing the diaphragm assemblies.

Use a $1\frac{3}{8}$ " (35mm) wrench or six pointed socket to remove the diaphragm assemblies (outer plate, diaphragm, and inner plate) from the diaphragm rod (item 33) by turning counterclockwise.

Insert a 1/4-20 capscrew or set screw into the smaller tapped hole in the inner diaphragm plate (item 30). Insert the protruding stud and the 1/4-20 fastener loosely into a vise. Use a

$1\frac{3}{8}$ " wrench or socket to remove the outer diaphragm plate (item 29) by turning counterclockwise. Inspect the diaphragm (item 17) for cuts, punctures, abrasive wear or chemical attack. Replace the diaphragms if necessary.

Step #4: Installing the diaphragms.

Push the threaded stud of the outer diaphragm plate through the center hole of the diaphragm. Thread the inner plate clockwise onto the stud. Use a torque wrench to tighten the diaphragm assembly together to 480 in Lbs. (54.23 Newton meters). Allow a minimum of 15 minutes to elapse after torquing, then re-torque the assembly to compensate for stress relaxation in the clamped assembly.

Step #5: Installing the diaphragm assemblies to the pump.

Make sure the bumper (item 6) is installed over the diaphragm rod.

Thread the stud of the one diaphragm assembly clockwise into the tapped hole at the end of the diaphragm rod (item 33) until the inner diaphragm plate is flush to the end of the rod. Insert rod into pump.

Align the bolt holes in the diaphragm with the bolt pattern in the inner chamber (item 16). Make sure the molded directional arrows on the diaphragm point vertically.

Fasten the outer chamber (item 15) to the pump, using the capscrews (items 9 & 12), hex nuts and flat washers.

On the opposite side of the pump, pull the diaphragm rod out as far as possible. Make sure the bumper (item

6) is installed over the diaphragm rod.

Thread the stud of the remaining diaphragm assembly clockwise into the tapped hole at the end of the diaphragm rod (item 33) as far as possible and still allow for alignment of the bolt holes in the diaphragm with the bolt pattern in the inner chamber. The molded directional arrows on the diaphragm must point vertically.

Fasten the remaining outer chamber (item 15) to the pump, using the capscrews (items 9 & 12), hex nuts and flat washers.

Step #6: Re-install the elbow/spacer/manifold assemblies to the pump, using the capscrews (items 11), hex nuts and flat washers.

The pump is now ready to be re-installed, connected and returned to operation.

OVERLAY DIAPHRAGM SERVICING

The PTFE overlay diaphragm (item 18) is designed to fit snugly over the exterior of the standard TPE diaphragm (item 17).

The molded directional arrows on the overlay diaphragm must point vertically.

Follow the same procedures described for the standard diaphragm for removal and installation.



! IMPORTANT

Read these instructions completely, before installation and start-up. It is the responsibility of the purchaser to retain this manual for reference. Failure to comply with the recommendations stated in this manual will damage the pump, and void factory warranty.

PUMPING HAZARDOUS LIQUIDS

When a diaphragm fails, the pumped liquid or fumes enter the air end of the pump. Fumes are exhausted into the surrounding environment. When pumping hazardous or toxic materials, the exhaust air must be piped to an appropriate area for safe disposal. See illustration #1 at right.

This pump can be submerged if the pump materials of construction are compatible with the liquid being pumped. The air exhaust must be piped above the liquid level. See illustration #2 at right. Piping used for the air exhaust must not be smaller than 1" (2.54 cm) diameter. Reducing the pipe size will restrict air flow and reduce pump performance. When the pumped product source is at a higher level than the pump (flooded suction condition), pipe the exhaust higher than the product source to prevent siphoning spills. See illustration #3 at right.

CONVERTING THE PUMP FOR PIPING THE EXHAUST AIR

The following steps are necessary to convert the pump to pipe the exhaust air away from the pump.

Use a #8 Torx or flat screwdriver to remove the six self-tapping screws (item 1-J).

Remove the muffler cap and muffler (items 1-D and 1-F). The 1" NPT molded threads in the air distribution valve body (item 1-B).

Piping or hose may now be installed.
IMPORTANT INSTALLATION

NOTE: The manufacturer recommends installing a flexible hose or connection between the pump and any rigid plumbing. This reduces stresses on the molded plastic threads of the air exhaust port. Failure to do so may result in damage to the air distribution valve body.

Any piping or hose connected to the pump's air exhaust port must be physically supported. Failure to support these connections could also result in damage to the air distribution valve body.

Exhaust Conversion Drawing

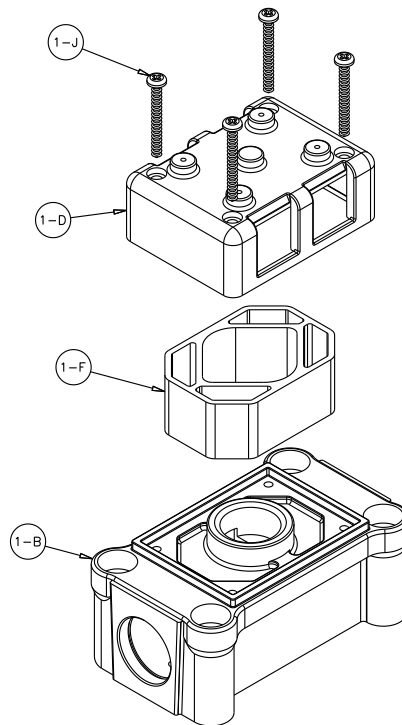

CONVERTED EXHAUST ILLUSTRATION

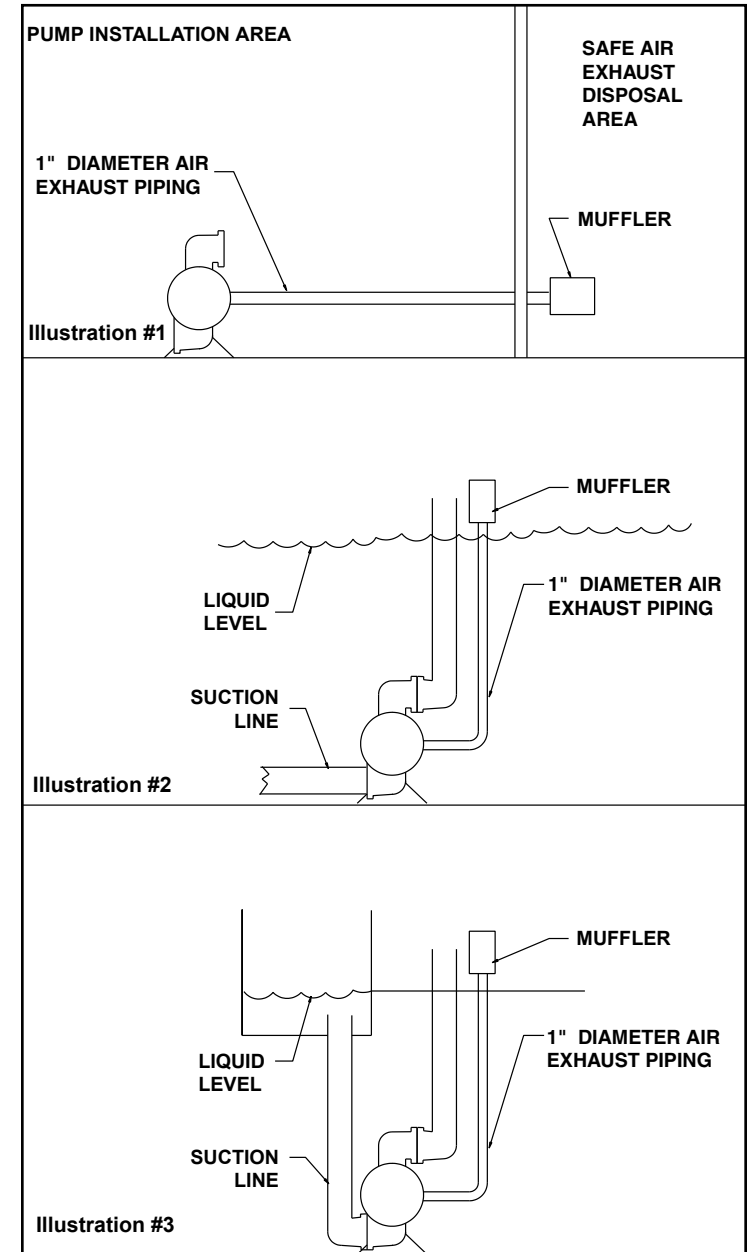

MODULAR CHECK VALVE SERVICING

Before servicing the check valves, first shut off the suction line and then the discharge line to the pump. Next, shut off the compressed air supply, bleed air pressure from the pump, and disconnect the air supply line from the pump. Drain any remaining fluid from the pump. The pump can now be removed for service.

To access the modular check valve, remove the elbows (items 19 from pump composite repair parts drawing). Use a $\frac{9}{16}$ " wrench or socket to remove the fasteners. Once the elbows are removed, the modular check valves can be seen in the cavities of the outer chamber (items 15).

Next remove the check valve seal (item 37). Inspect the seal for cuts or pinched areas. Replace seal as needed.

Disassemble the component parts of each modular check valve. Inspect the check valve retainer (item 32) for cuts, abrasive wear, or embedded materials. Replace as needed.

Inspect the check balls (items 3) for wear, abrasion, or cuts on the spherical surface. The check valve seats (items 38) should be inspected for cuts, abrasive wear, or embedded material on the surfaces of both the external and internal chamfers. The spherical surface of the check balls must seat flush to the surface of the inner chamfer on the check valve seats for the pump to operate to peak efficiency. Replace any worn or damaged parts as necessary.

Remove the remaining check valve seal (item 37). Inspect the seal for cuts or pinched areas. Replace seal as needed.

Re-assemble the modular check valve. The seat should fit snugly into the retainer.

Place a check valve seal (item 37) into the cavity of the outer chamber (item 15). Make sure the chamfer side of the seal faces out. Insert the modular check valve into the outer chamber with the retainer facing up. Install a check valve seal (item 37). Make sure the chamfer side of the seal faces the chamfer on the check valve seat or retainer.

The pump can now be reassembled, reconnected and returned to operation.

Modular Check Valve Drawing

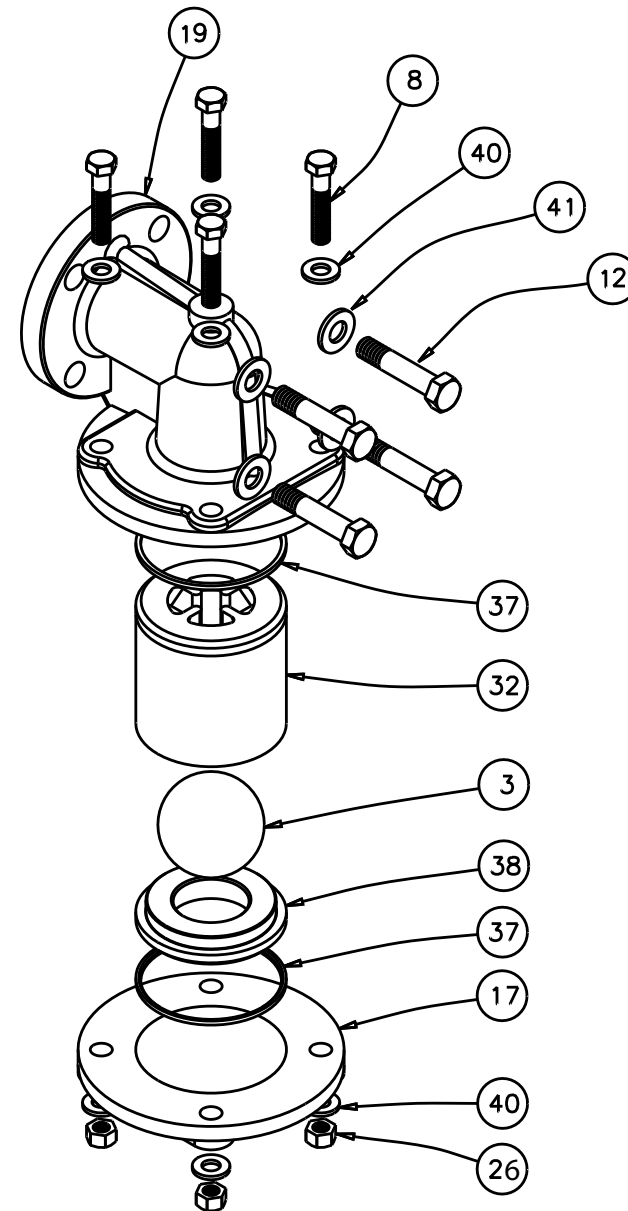

Dual Port Option Drawing

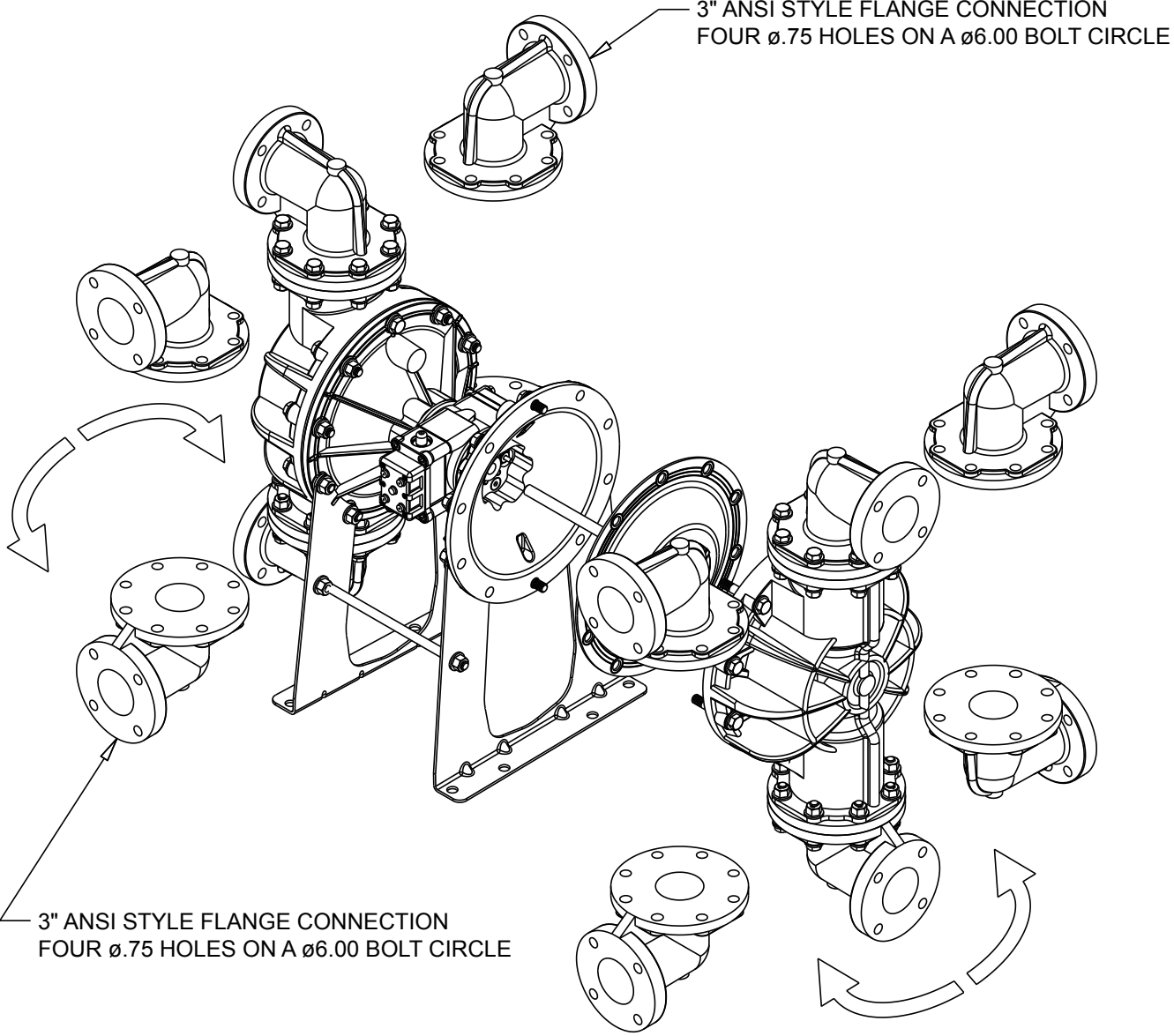

DUAL PORTING OPTIONS

Several dual porting options are possible. The pump can be converted to a dual port arrangement on both the suction and the discharge ends. The porting can be configured to a single suction and a dual discharge. The porting can be changed to a dual suction and a single discharge.

The above changes are possible because the porting flange of the elbows (items 19) are designed to mate with standard 125# ANSI style 4-bolt, 3" pipe flanges.

Dual porting of both suction and discharge ends of the pump

Converting the pump from the standard single suction and discharge porting configuration to dual porting at each end is easy. Simply remove the manifold seals, spacers, and manifolds (items 36, 39, and 24 from pump assembly drawing) from the pump.

The discharge and suction elbows can be rotated at 90° increments (see arrows and optional positioning in the Dual Porting Drawing.

Single porting of the suction and dual porting of the pump discharge

To convert the pump from the standard single suction and single discharge porting configuration to a dual discharge porting arrangement remove the only the discharge manifolds, spacers, and manifold seals. Position the discharge elbows in the desired direction at 90° increments. (See arrows and optional positioning in the Dual Porting Drawing.)

Dual porting of the suction and single porting of the pump discharge

To convert the pump from the standard single suction and single discharge porting configuration to a dual suction porting arrangement remove the only the suction (bottom) manifolds, spacers, and manifold seals.

Position the suction elbows in the desired direction at 90° increments. (See arrows and optional positioning in the Dual Porting Drawing.)



! IMPORTANT

Read these instructions completely, before installation and start-up. It is the responsibility of the purchaser to retain this manual for reference. Failure to comply with the recommendations stated in this manual will damage the pump, and void factory warranty.

Leak Detection Options Drawing

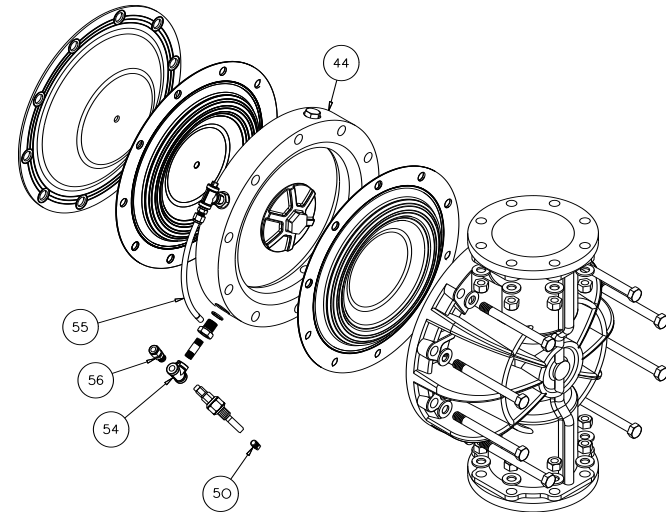
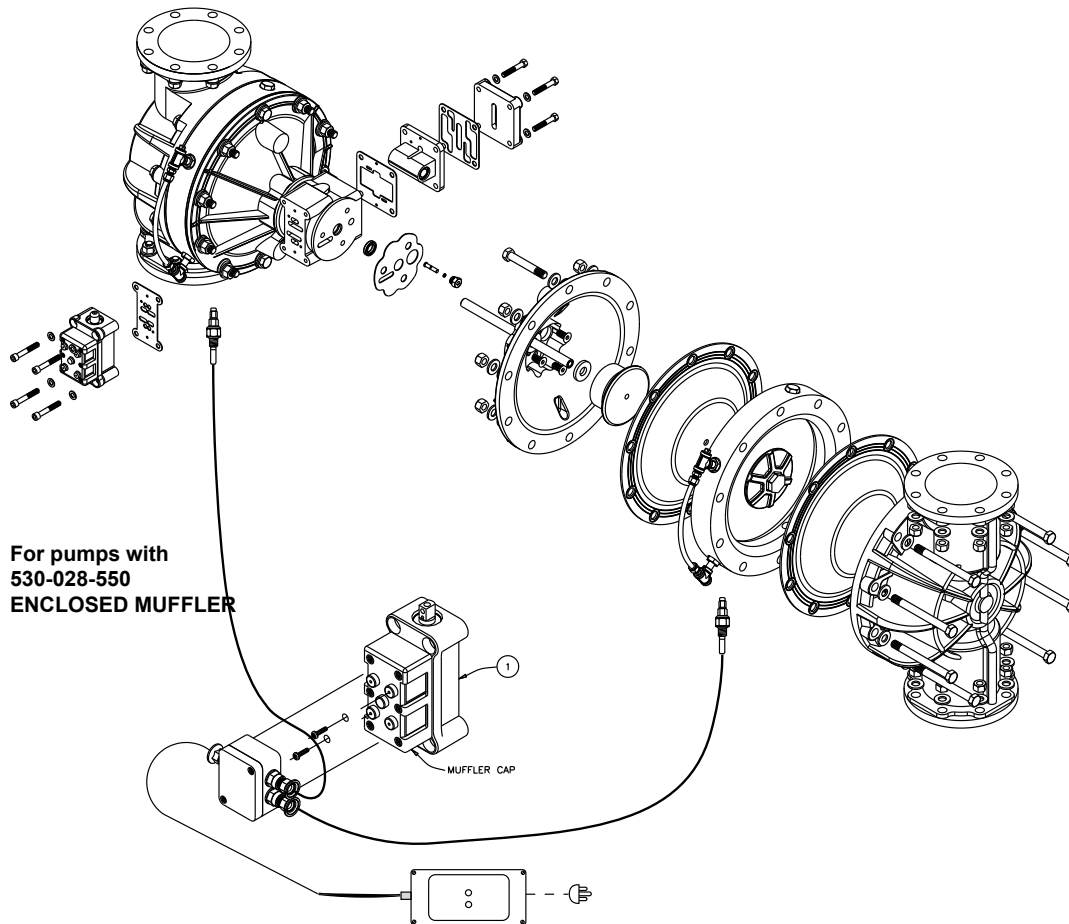

LEAK DETECTION OPTION (ELECTRONIC)

Follow instructions found elsewhere in this manual, "Filling the Spill Containment Chambers" when installing leak detectors.

Electronic Leak Detector Installation

Kit 032-037-000	100VAC	50Hz
	or 110-120VAC	50/60Hz
	or 220-240VAC	50/60Hz

Kit 032-045-000 12-32VDC

To install electronic leak detectors, remove the bottom 1/4" NPT pipe plug on the visual sight tube (item 52). Insert leak detector into the 1/4" pipe tee (item 56).

LEAK DETECTION OPTION (MECHANICAL)

Follow instructions found elsewhere in this manual, "Filling the Spill Containment Chambers" when installing leak detectors.

Mechanical Leak Detector Installation

Kit 031-023-110

To install mechanical leak detectors, remove the bottom 1/4" NPT pipe plug on the visual sight tube (item 52). Insert leak detector into the 1/4" pipe tee (item 56).

Pulse Output Kit Drawing

PULSE OUTPUT KIT OPTION

This pump can be fitted with a Pulse Output Kit. This converts the mechanical strokes of the pump to an electrical signal which interfaces with the Stroke Counter/ Batch Controller or user control devices such as a PLC.

The Pulse Output Kits mount directly onto the Muffler Cap on the Air Distribution Valve Assembly or onto the air valve and senses each stroke of the main spool.

Consult the factory for further information and availability.

Pulse Output Kits

475-244-001	10-30 VDC
475-244-002	110/220 VAC
475-244-003	10-30VDC, 110VAC and 220 VAC

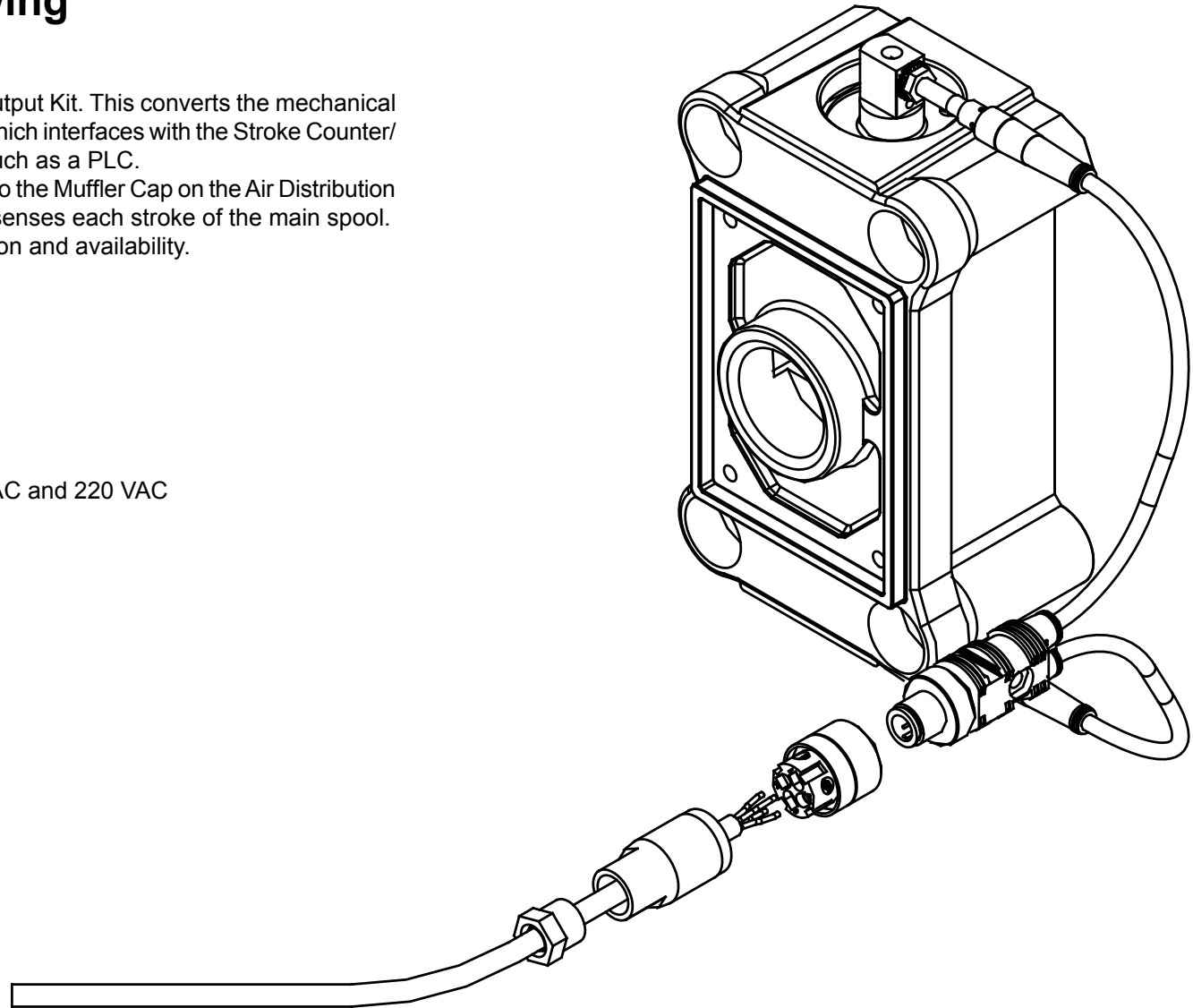

Leak Detection Options Drawing

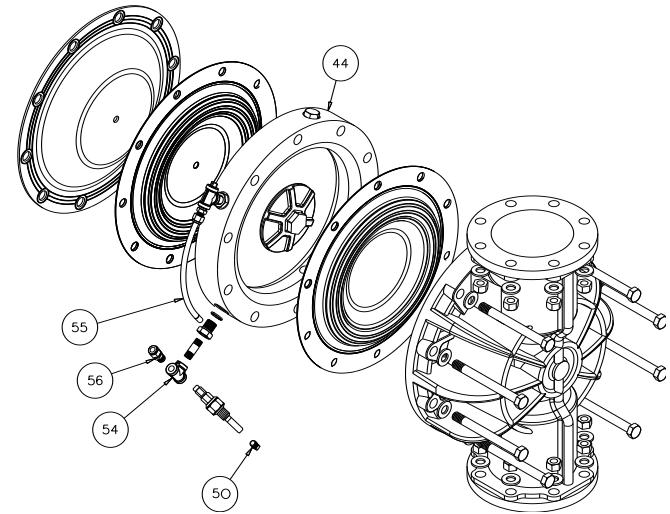
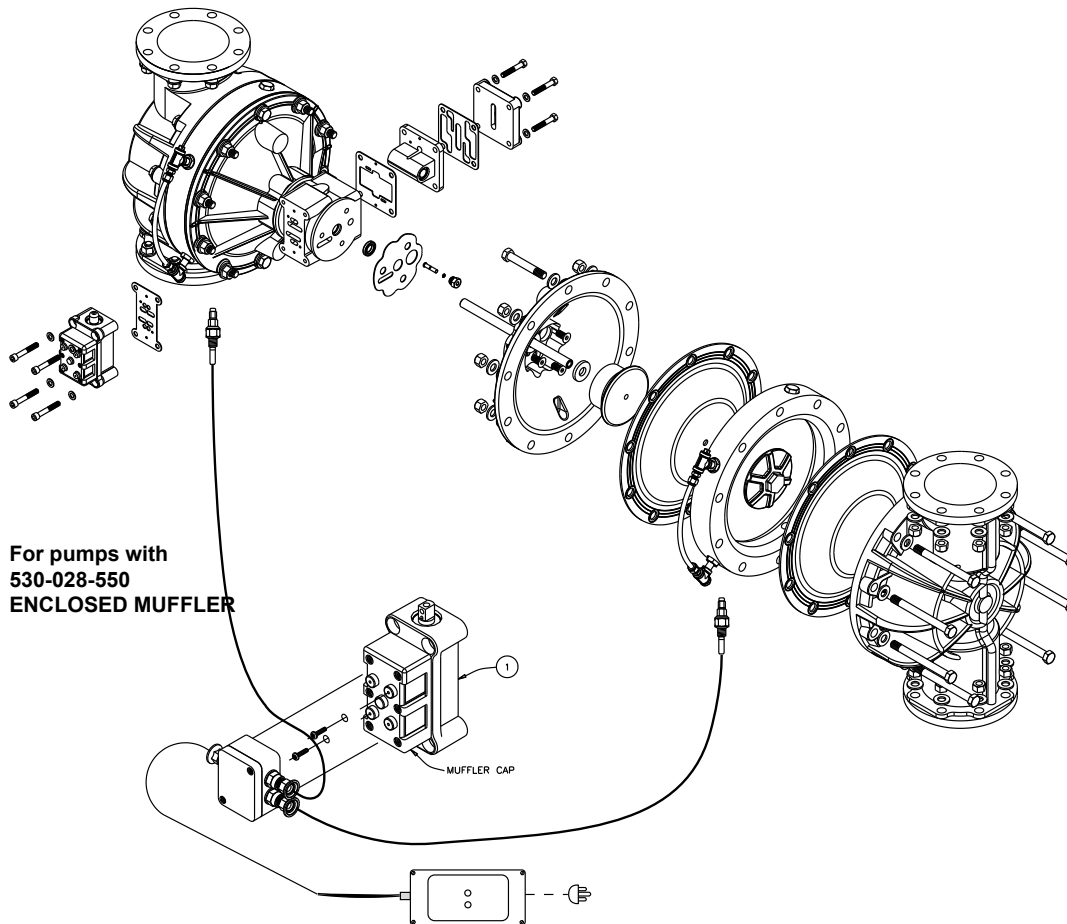

LEAK DETECTION OPTION (ELECTRONIC)

Follow instructions found elsewhere in this manual, "Filling the Spill Containment Chambers" when installing leak detectors.

Electronic Leak Detector Installation

Kit 032-037-000	100VAC	50Hz
	or 110-120VAC	50/60Hz
	or 220-240VAC	50/60Hz

Kit 032-045-000 12-32VDC

To install electronic leak detectors, remove the bottom 1/4" NPT pipe plug on the visual sight tube (item 52). Insert leak detector into the 1/4" pipe tee (item 56).

LEAK DETECTION OPTION (MECHANICAL)

Follow instructions found elsewhere in this manual, "Filling the Spill Containment Chambers" when installing leak detectors.

Mechanical Leak Detector Installation

Kit 031-023-110

To install mechanical leak detectors, remove the bottom 1/4" NPT pipe plug on the visual sight tube (item 52). Insert leak detector into the 1/4" pipe tee (item 56).

Optional Muffler Configurations, Drawing

OPTION 0

530-028-550 Integral Muffler uses (1) Cap and (4) 710-015-115 Self Tapping Screw to hold it in place.

OPTION 1

530-027-000 Sound Dampening Muffler screws directly into the Air Valve body. This muffler is equipped with a porous plastic element.

OPTION 2

530-010-000 Mesh Muffler screws directly into the Air Valve Body. This muffler is equipped with a metal element.

OPTION 6

530-033-000 Metal Muffler screws directly into the Air Body.

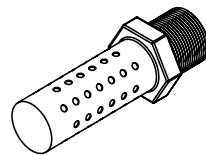

Option 6

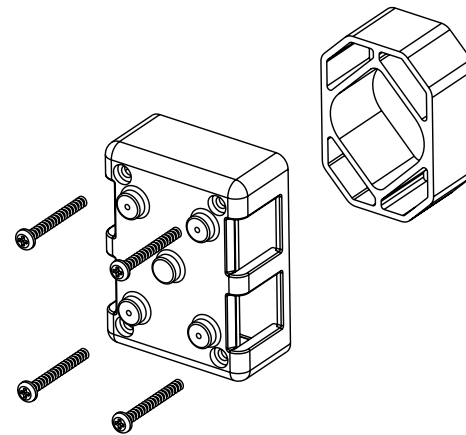

Option 0

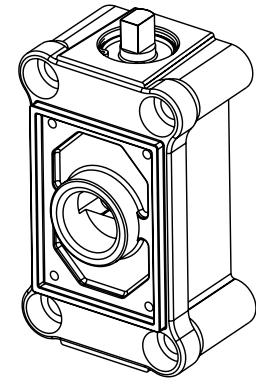

Option 1 and 2

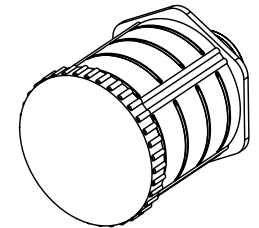

**WARREN
RUPP, INC.[®]**

Declaration of Conformity

**Manufacturer: Warren Rupp, Inc.[®], 800 N. Main Street
Mansfield, Ohio, 44902 USA**

Certifies that Air-Operated Double Diaphragm Pump Series: HDB, HDF, M Non-Metallic, S Non-Metallic, M Metallic, S Metallic, T Series, G Series, U Series, EH and SH High Pressure, RS Series, W Series, SMA and SPA Submersibles, and Tranquilizer[®] Surge Suppressors comply with the European Community Directive 2006/42/EC on Machinery, according to Annex VIII. This product has used Harmonized Standard EN809:1998+A1:2009, Pumps and Pump Units for Liquids - Common Safety Requirements, to verify conformance.

David Roseberry
Signature of authorized person

David Roseberry
Printed name of authorized person

Revision Level: F

October 20, 2005
Date of issue

Engineering Manager
Title

August 23, 2012
Date of revision

IDEX
FLUID & METERING

