

SERVICE & OPERATING MANUAL

Original Instructions



Certified Quality



intertek

Total Quality. Assured.

ISO 9001 Certified
ISO 14001 Certified



EAC

UK
CA

Warren Rupp, Inc.
A Unit of IDEX Corporation
800 N. Main St.,
Mansfield, Ohio 44902 USA
Telephone (419) 524.8388
Fax (419) 522.7867
SANDPIPERPUMP.COM



© Copyright 2025 Warren Rupp, Inc.
All rights reserved

EvolutionX

Model SPE10

1" Non-Metallic Pump Design Level 1

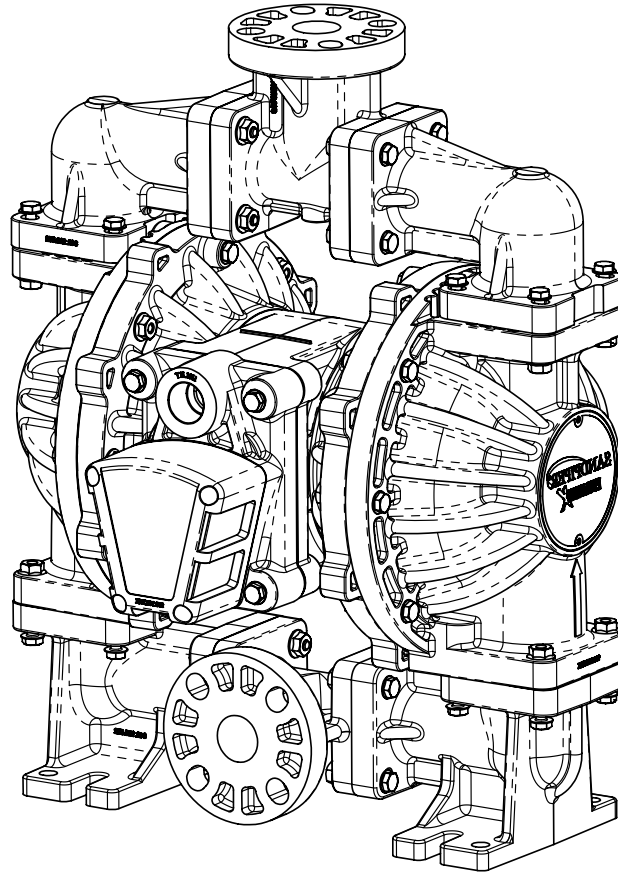

1: PUMP SPECS

2: INSTAL & OP

3: EXP VIEW

4: AIR END

6: OPTIONAL

7: WARRANTY

SANDPIPER[®]
A WARREN RUPP, INC. BRAND

SANDPIPERPUMP.COM

Safety Information

! IMPORTANT



Read the safety warnings and instructions in this manual before pump installation and start-up. Failure to comply with the recommendations stated in this manual could damage the pump and void factory warranty.



When the pump is used for materials that tend to settle out or solidify, the pump should be flushed after each use to prevent damage. In freezing temperatures the pump should be completely drained between uses.

! CAUTION



Before pump operation, inspect all fasteners for loosening caused by gasket creep. Retighten loose fasteners to prevent leakage. Follow recommended torques stated in this manual.



Nonmetallic pumps and plastic components are not UV stabilized. Ultraviolet radiation can damage these parts and negatively affect material properties. Do not expose to UV light for extended periods of time.



WARNING

Pump not designed, tested or certified to be powered by compressed natural gas. Powering the pump with natural gas will void the warranty.



WARNING

The use of non-OEM replacement parts will void (or negate) agency certifications, including CE, ATEX, CSA, 3A and EC1935 compliance (Food Contact Materials). Warren Rupp, Inc. cannot ensure nor warrant non-OEM parts to meet the stringent requirements of the certifying agencies.

! WARNING



When used for toxic or aggressive fluids, the pump should always be flushed clean prior to disassembly.



Before maintenance or repair, shut off the compressed air line, bleed the pressure, and disconnect the air line from the pump. Be certain that approved eye protection and protective clothing are worn at all times. Failure to follow these recommendations may result in serious injury or death.



Airborne particles and loud noise hazards. Wear eye and ear protection.



In the event of diaphragm rupture, pumped material may enter the air end of the pump, and be discharged into the atmosphere. If pumping a product that is hazardous or toxic, the air exhaust must be piped to an appropriate area for safe containment.



Take action to prevent static sparking. Fire or explosion can result, especially when handling flammable liquids. The pump, piping, valves, containers and other miscellaneous equipment must be properly grounded.



This pump is pressurized internally with air pressure during operation. Make certain that all fasteners and piping connections are in good condition and are reinstalled properly during reassembly.



Use safe practices when lifting

ATEX Pumps - Conditions For Safe Use

1. Ambient temperature range is as specified in tables 1 to 3 on the next page (per Annex I of DEKRA 18ATEX0094X)
2. ATEX compliant pumps are suitable for use in explosive atmospheres when the equipment is properly grounded in accordance with local electrical codes
3. **Non-Metallic ATEX Pumps only — See Explanation of Pump Nomenclature / ATEX Details Page**
Conductive Polypropylene, conductive Acetal or conductive PVDF pumps are not to be installed in applications where the pumps may be subjected to oil, greases and hydraulic liquids.
4. The optionally provided solenoids shall be protected by a fuse corresponding to its rated current (max $3 \cdot I_{rat}$ according to EN 60127) or by a motor protecting switch with short circuit and thermal instantaneous tripping (set to the rated current) as short circuit protection. For solenoids with a very low rated current, a fuse with the lowest current value according to the indicated standard will be sufficient. The fuse may be accommodated in the associated supply unit or shall be separately arranged. The rated voltage of the fuse shall be equal or greater than the stated rated voltage of the solenoid. The breaking capacity of the fuse shall be as high as or higher than the maximum expected short circuit current at the location of the installation (usually 1500 A). The maximum permissible ripple is 20% for all dc solenoids.
***Not applicable for all pump models — See Explanation of Pump Nomenclature / ATEX Details Page**
5. When operating pumps equipped with non-conductive diaphragms that exceed the maximum permissible projected area, as defined in EN ISO 80079-36 : 2016 section 6.7.5 table 8, the following protection methods must be applied
 - Equipment is always used to transfer electrically conductive fluids or
 - Explosive environment is prevented from entering the internal portions of the pump, i.e. dry running.
6. Pumps provided with the pulse output kit and used in the potentially explosive atmosphere caused by the presence of the combustible dust shall be installed in such a way that the pulse output kit is protected against impact
***Not applicable for all pump models — See Explanation of Pump Nomenclature / ATEX Details Page**

ATEX Compliant Pump Temperature Ratings

Table 1. Category 1 & Category 2 ATEX Rated Pumps

Ambient Temperature Range	Process Temperature Range	Temperature Class	Maximum Surface Temperature
-20°C to +60°C	-20°C to +80°C	T5	T100°C
	-20°C to +108°C	T4	T135°C
	-20°C to +160°C	T3	T200°C
	-20°C to +177°C	(225°C) T2	

Table 2. Category 2 ATEX Rated Pumps Equipped with Pulse Output Kit or Integral Solenoid

Ambient Temperature Range	Process Temperature Range	Temperature Class	Maximum Surface Temperature	Kit Options	
				Pulse Output Kit	Integral Solenoid
-20°C to +60°C	-20°C to +100°C	T5	T100°C	✓	
-20°C to +50°C	-20°C to +100°C	T5	T100°C		✓

Table 3. Category M1 ATEX Rated Pumps for Mining

Ambient Temperature Range	Process Temperature Range
-20°C to +60°C	-20°C to +150°C

Notes

1. The ambient temperature range and the process temperature range should not exceed the operating temperature range of the applied non-metallic parts as listed in the table below.
2. ATEX Pulse output or integral solenoid not available for all pump models, see Pump Nomenclature page
3. G-Series natural gas pumps are restricted to a process temperature range of (-20°C to +80°C)

Table 4. Material Operating Temperatures

Material	Description	Operating Temperatures	
		Min.	Max.
Conductive Acetal	Tough, impact & abrasion resistant, low friction coefficient; generally inert, good chemical resistance except for strong acids and oxidizing agents	-20°F (-29°C)	190°F (88°C)
EPDM	Very good water & chemical resistance; poor resistance to oils & solvents; fair in ketones and alcohols	-40°F (-40°C)	280°F (138°C)
FKM (Fluorocarbon)	Good resistance to wide range of oils & solvents especially aliphatic, aromatic & halogenated hydrocarbons, acids, animal and vegetable oils; hot water & hot aqueous solutions (over 70°F [21°C]) attack FKM	-40°F (-40°C)	350°F (177°C)
Hytrel®	Good resistance to acids, bases, amines and glycols at room temperature	-20°F (-29°C)	220°F (104°C)
Neoprene	All purpose; resistance to vegetable oils; generally not affected by moderate chemicals, fats, greases, oils and solvents; attacked by strong oxidizing acids, ketones, esters, nitro & chlorinated aromatic hydrocarbons	-10°F (-23°C)	200°F (93°C)
Nitrile	Good solvent, oil, water & hydraulic fluid resistance; do not use with highly polar solvents (acetone & MEK), ozone, chlorinated & nitro hydrocarbons	-10°F (-23°C)	190°F (88°C)
Nylon	High strength & toughness over a wide temperature range; moderate to good resistance to fuels, oils & chemicals	32°F (0°C)	180°F (82°C)
Polypropylene	Thermoplastic, moderate tensile & flex strength. Resists strong acids & alkali. Attacked by chlorine, fuming nitric acid and other strong oxidizing agents	32°F (0°C)	180°F (82°C)
PVDF	Durable fluoroplastic with excellent chemical resistance; excellent for UV applications; high tensile strength and impact resistance	0°F (-18°C)	250°F (121°C)
Santoprene®	Thermoplastic elastomer with no fabric layer; long mechanical flex life; excellent abrasion resistance.	-40°F (-40°C)	275°F (135°C)
UHMW PE	Thermoplastic highly resistant to a broad range of chemicals; outstanding abrasion & impact resistance, environmental stress-cracking resistance	-35°F (-37°C)	180°F (82°C)
Urethane	Good resistance to abrasives; poor resistance to most solvents and oils	32°F (0°C)	150°F (66°C)
Virgin PTFE	Chemically inert, virtually impervious. Few chemicals react with PTFE, turbulent liquid or gaseous fluorine and a few fluoro-chemicals such as chlorine trifluoride or oxygen difluoride which readily liberate free fluorine at elevated temperatures.	-35°F (-37°C)	220°F (104°C)

Table of Contents

1: PUMP SPECS

SECTION 1: PUMP SPECIFICATIONS.....1

- Explanation of Nomenclature
- Performance
- Materials
- Dimensional Drawings

2: INSTAL & OP

SECTION 2: INSTALLATION & OPERATION ...5

- Principle of Pump Operation
- Recommended Installation Guide
- Troubleshooting Guide

3: EXP VIEW

SECTION 3: EXPLODED VIEW.....8

- Composite Repair Parts Drawing
- Composite Repair Parts List
- Material Codes
- Option For Virgin PTFE & TPE Equipped Pumps Drawing

4: AIR END

SECTION 4: AIR END13

- Air Distribution Valve Assembly
- Air Valve with Stroke Indicator Assembly
- Pilot Valve Assembly
- Intermediate Assembly

5: WET END

SECTION 5: WET END.....17

- Diaphragm Drawings
- Diaphragm Servicing

6: OPTIONAL

SECTION 6: OPTIONAL CONFIGURATIONS .19

- Solenoid Shifted Air Valve
- Dual Port
- Electronic Leak Detector Installation Instructions

7: WARRANTY

SECTION 7: WARRANTY & CERTIFICATES ..22

- Warranty
- CE Declaration of Conformity - Machinery
- ATEX Declaration of Conformity

Explanation of Pump Nomenclature

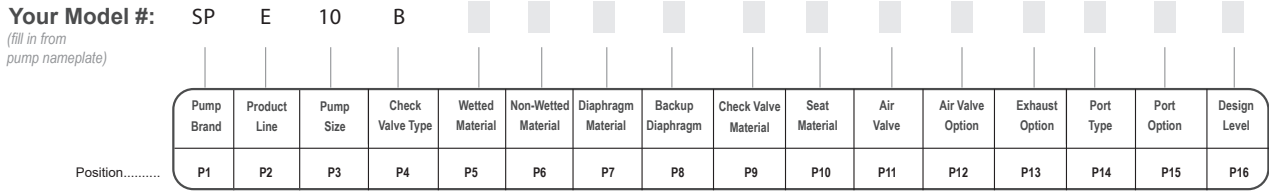

PUMP BRAND

SP SANDPIPER

PRODUCT LINE

E Evolution

PUMP SIZE

10 1"

CHECK VALVE TYPE

B Ball

WET END MATERIALS

C Conductive Polypropylene

K PVDF (Kynar)

P Polypropylene

NON-WETTED MATERIAL

C Conductive Polypropylene

P Polypropylene

DIAPHRAGM MATERIAL

B Nitrile (Buna)

E EPDM

H Hytrel (FDA Compliant)

N Neoprene

R Santoprene

T PTFE Overlay

V FKM (Viton)

Z One Piece Bonded PTFE

***BACKUP DIAPHRAGM**

B Nitrile (Buna)

N Neoprene

R Santoprene

O None

CHECK VALVE MATERIAL

B Nitrile

N Neoprene

R Santoprene

T PTFE

SEAT MATERIAL

K PVDF (Kynar)

P Polypropylene

AIR VALVE

0 SANDPIPER Standard

AIR VALVE OPTION

0 Matched ground sleeve and spool

B Stainless / Brass sleeve & spool set

*S Stainless / Brass sleeve & spool set - Aluminum free pump

EXHAUST OPTION

0 Encapsulated Polypropylene

1 Encapsulated Conductive Polypropylene

6 Threaded Muffler (Conductive)

PORT TYPE

U Universal ANSI/DIN Flange

N NPT Threads

B BSP Threads

PORT Option

C Center Ported

D Dual Suction / Dual Discharge

E End Ported

F Suction Only Dual Ported

G Discharge Only Dual Ported

DESIGN LEVEL

1 Design Level

*If T is selected for Diaphragm Material, select backup diaphragm "N or R"

*If Z is selected for Diaphragm Material, the backup will be "B"

*For all other Diaphragm Materials, the backup will be "O"

*Pumps with stainless brass sleeve and spool main air valve option, do not contain Aluminum. Equipped with stainless steel pilot sleeve and stainless steel inner diaphragm plate.

Your Serial #: (fill in from pump nameplate) _____

ATEX Detail

	ATEX Details	Wetted Material Options	Non- Wetted Material Options	Exhaust Options	Port Options
	II 1 G Ex h IIC T5....225°C (T2) Ga II 1 D Ex h IIIC T100°C....T200°C Da I M1 Ex h I Ma	C	C	6	C, D, F, G
	II 2 G Ex h IIC T5....225°C Gb II 2 D Ex h IIIC T100°C....T200°C Db	C	C	1	C, D, F, G

Performance

SPE10 NON-METALLIC

1: PUMP SPECS

FLUID PORT SIZE

- 1" ANSI/DIN Flange

AIR INLET PORT

- 3/4" NPT Threaded

CAPACITY

- 0 to 63 gallons per minute
(0 to 238 liters per minute)

AIR DISTRIBUTION VALVE

- No-lube, no-stall design

SOLIDS-HANDLING

- Up to .25 in. (6mm)

HEADS UP TO

- 125 psi or 288 ft. of water
(8.6 bar or 88 meters)

DISPLACEMENT/STROKE

- .22 Gallon / .83 liter

MAXIMUM OPERATING PRESSURE

- 125 psi (8.6 bar)

SHIPPING WEIGHT

- Polypropylene 25 lbs. (11.3 kg)
- PVDF 42 lbs. (19kg)

MODEL Evolution X Performance Curve

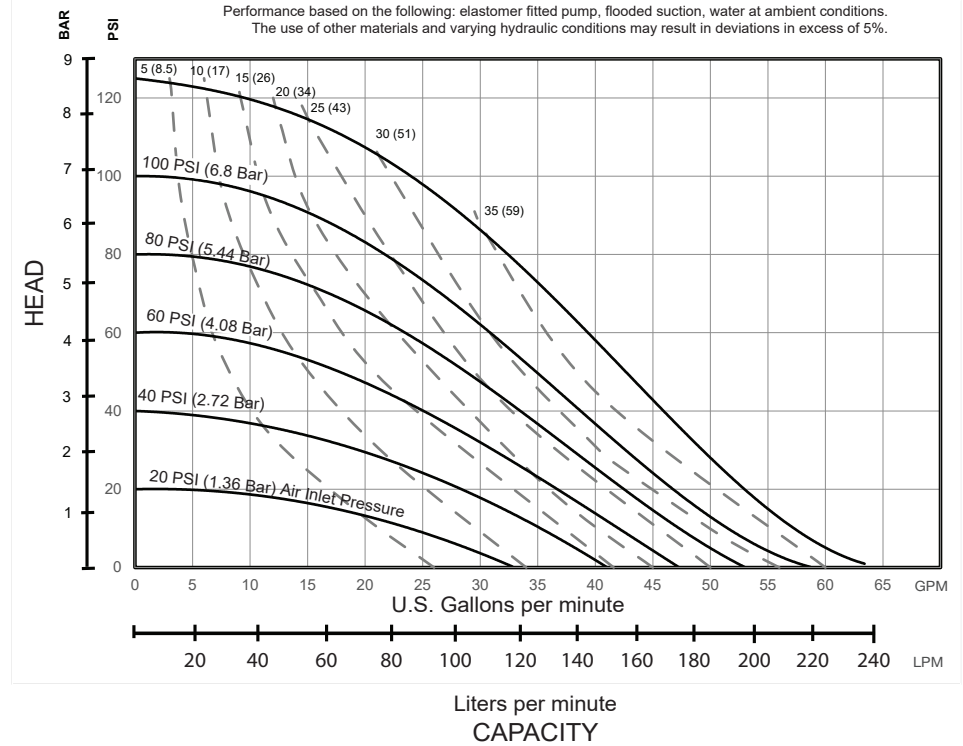

Spacer used to match S1F center ported height in vertical discharge applications.

476.408.520 - PVDF Flange Spacer Kit

Part No.	Description	Quantity
334.127.520	ADAPTOR, FLANGE	1
720.044.600	PTFE SEAL	1

476.408.552 - Polypropylene Flange Spacer Kit

Part No.	Description	Quantity
334.127.552	ADAPTOR, FLANGE	1
720.044.600	PTFE SEAL	1

476.408.557 - Conductive Poly. Flange Spacer Kit

Part No.	Description	Quantity
334.127.557	ADAPTOR, FLANGE	1
720.044.600	PTFE SEAL	1

Air End Kits

476.404.000 Standard;

476.404.379 ATEX Compliant

476.404.162 Stainless Steel / Brass sleeve & spool, aluminum free pumps

Item No.	Description
1	Assembled valve body, includes main & pilot sleeve and spool sets
16	Bumpers
9	Air Valve Gasket
10	Air Inlet Cap Gasket
11	O-Rings, Nitrile
12	Actuator Pins
14	U-Cup Seals
15	Intermediate to Inner Chamber Seals

476.405.000 - Air Seal Kit

Item No.	Description
9	Air Valve Gasket
10	Air Inlet Cap Gasket
11	O-Rings, Nitrile
1-D	O-rings, Main Air Sleeve, Nitrile
1-FA	O-rings, Pilot Spool, Nitrile
1-GA	O-rings, Pilot Sleeve, Nitrile
14	U-Cup Seals
15	Intermediate to Inner Chamber Seals

Wet End Kits

476.406.363 - Viton Repair Kit

Item No.	Description
22	PTFE Check Balls
17	Viton Diaphragms
36	Check Valve Seals, PTFE
35	Manifold Seals - Center Ported

476.406.364 - EPDM Repair Kit

Item No.	Description
22	PTFE Check Balls
17	EPDM Diaphragms
36	Check Valve Seals, PTFE
35	Manifold Seals - Center Ported

476.406.350 - Hytrel Repair Kit

Item No.	Description
22	PTFE Check Balls
17	Hytrel Diaphragms
36	Check Valve Seals, PTFE
35	Manifold Seals - Center Ported

476.406.354 - Santoprene Repair Kit

Item No.	Description
22	Santoprene Check Balls
17	Santoprene Diaphragms
36	Check Valve Seals, PTFE
35	Manifold Seals - Center Ported

476.406.360 - Nitrile Repair Kit

Item No.	Description
22	Nitrile Check Balls
17	Nitrile Diaphragms
36	Check Valve Seals, PTFE
35	Manifold Seals - Center Ported

476.406.659 - Bonded PTFE Repair Kit

Item No.	Description
22	PTFE Check Balls
17	PTFE Bonded Diaphragm
36	Check Valve Seals, PTFE
35	Manifold Seals - Center Ported

476.406.635 - PTFE / Neoprene Repair Kit

Item No.	Description
22	PTFE Check Balls
17	Neoprene Diaphragms
18	PTFE Overlay Diaphragm
36	Check Valve Seals, PTFE
35	Manifold Seals - Center Ported

476.406.654 - PTFE / Santoprene Repair Kit

Item No.	Description
22	PTFE Check Balls
17	Santoprene Diaphragms
18	PTFE Overlay Diaphragm
36	Check Valve Seals, PTFE
35	Manifold Seals - Center Ported

476.406.365 - Neoprene Repair Kit

Item No.	Description
22	Neoprene Check Balls
17	Neoprene Diaphragms
36	Check Valve Seals, PTFE
35	Manifold Seals - Center Ported

Dimensional Drawings

SPE10 Non-Metallic Center Ported Options - Polypropylene, PVDF, Conductive Poly Wet Side

Dimensions in inches (metric dimensions in brackets). Dimensional Tolerance .125" (3mm).

1: PUMP SPECS

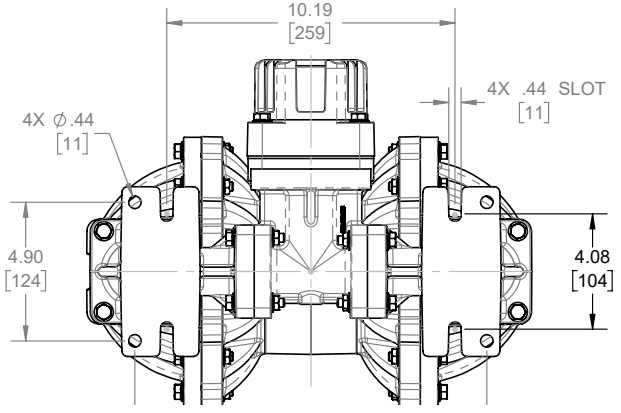
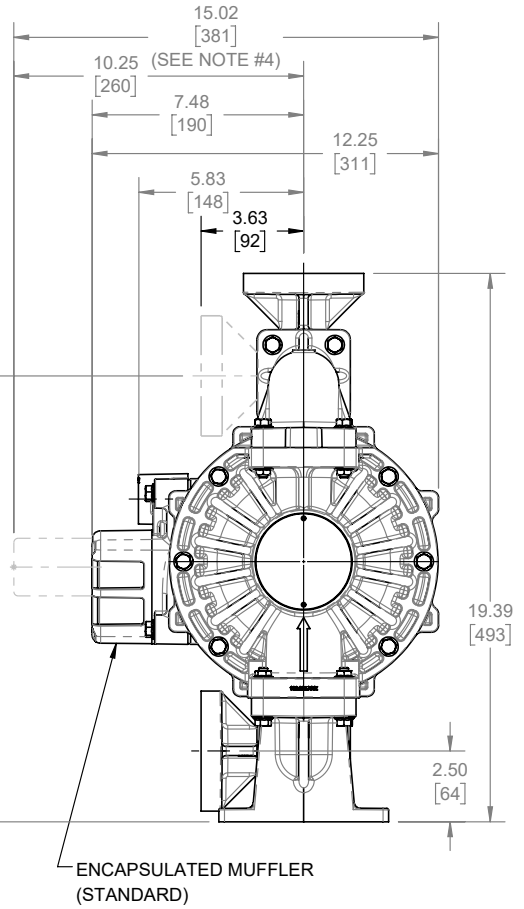
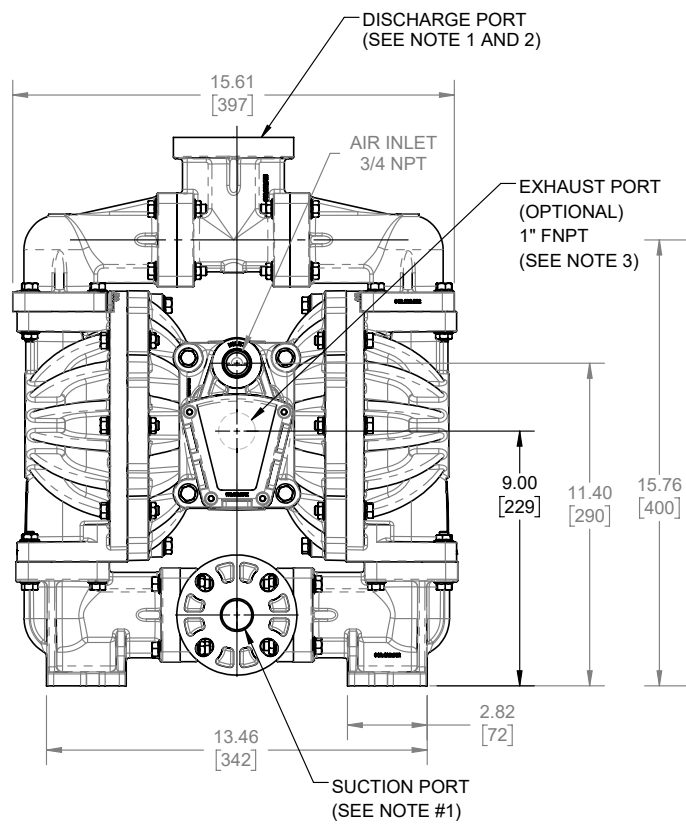
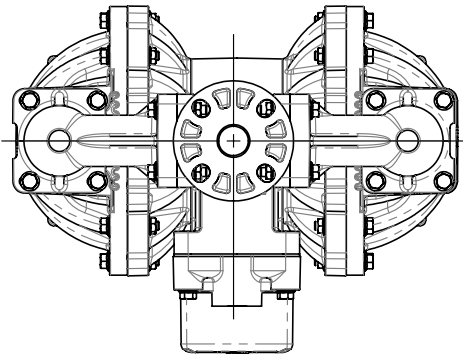

- NOTES
1. SUCTION AND DISCHARGE PORT FLANGES ARE DESIGNED TO FIT BOTH ANSI 125# CONNECTION AND PN10 50mm DIN CONNECTION
 2. DISCHARGE PORT CAN BE ROTATED 90° HORIZONTAL
 3. 1" FNPT EXHAUST OPTIONAL PORT FOR THREADED MUFFLER OR PIPING EXHAUST AIR IN SUBMERGED APPLICATIONS
 4. CONDUCTIVE THREADED MUFFLER (530.058.000) FOR ATEX CATEGORY 1 ONLY

Dimensional Drawings

SPE10 Non-Metallic End Ported Option- Polypropylene and PVDF Wet Side

Dimensions in inches (metric dimensions in brackets). Dimensional Tolerance .125" (3mm).

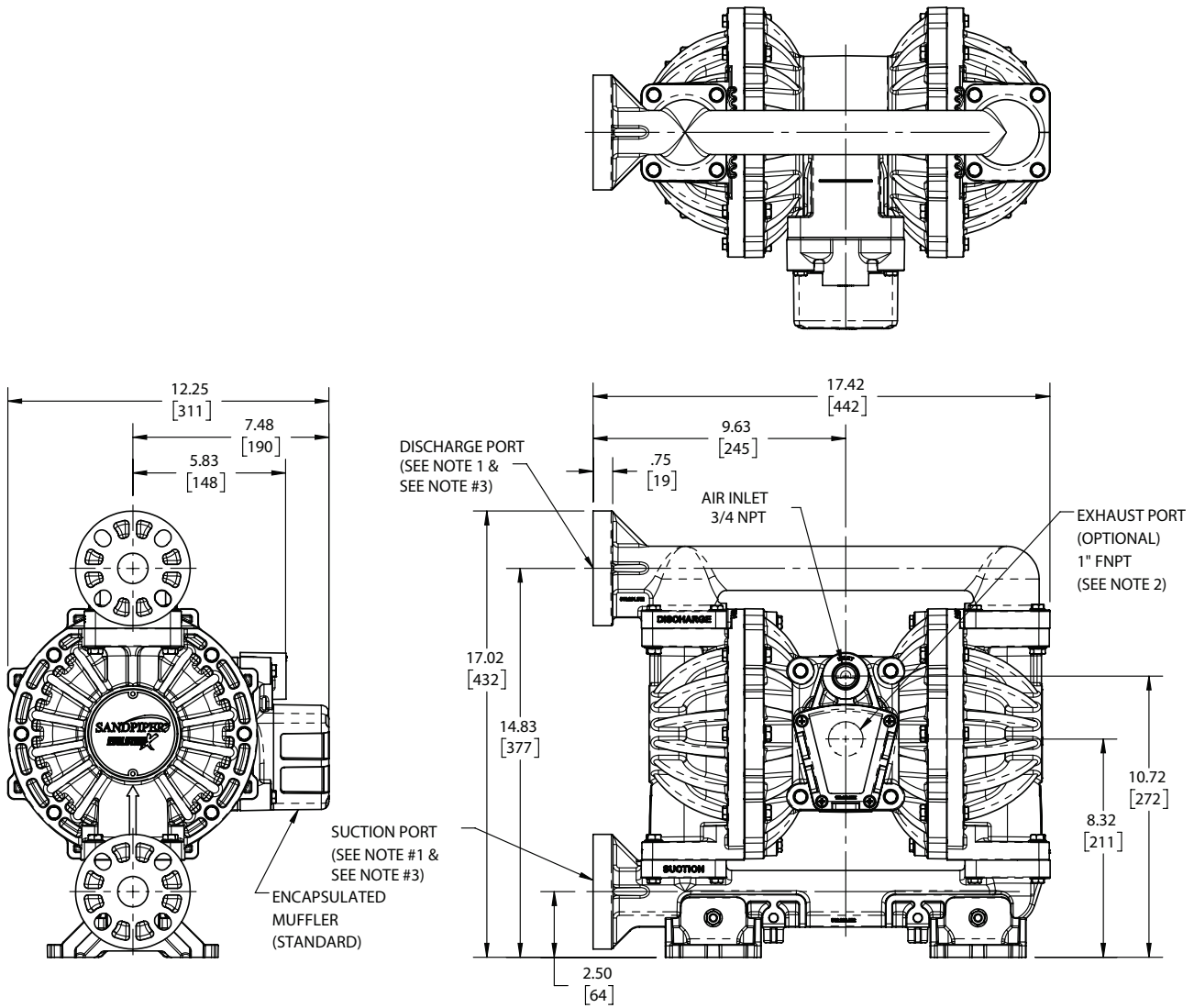

NOTES

1. SUCTION AND DISCHARGE PORT FLANGES ARE DESIGNED TO FIT BOTH ANSI 125# CONNECTION AND PN10 50mm DIN CONNECTION
2. 1" FNPT EXHAUST OPTIONAL PORT FOR THREADED MUFFLER OR PIPING EXHAUST AIR IN SUBMERGED APPLICATIONS
3. NPT AND BSP MANIFOLD OPTIONS AVAILABLE FOR THREADED CONNECTION APPLICATIONS

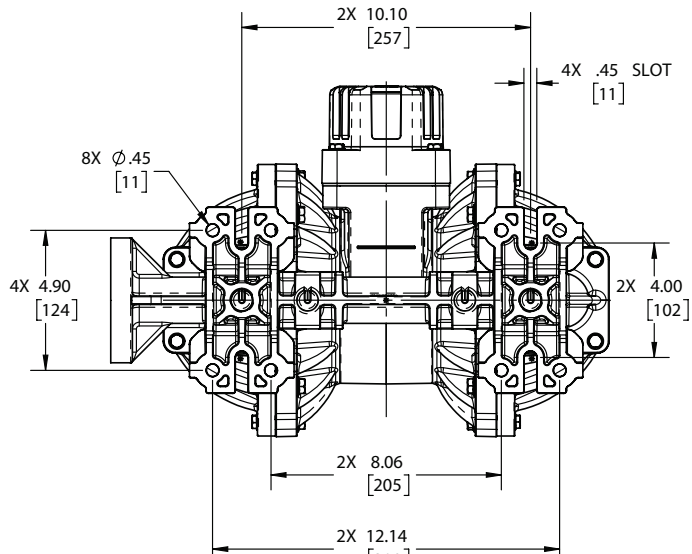

Pump Operation & Recommended Installation

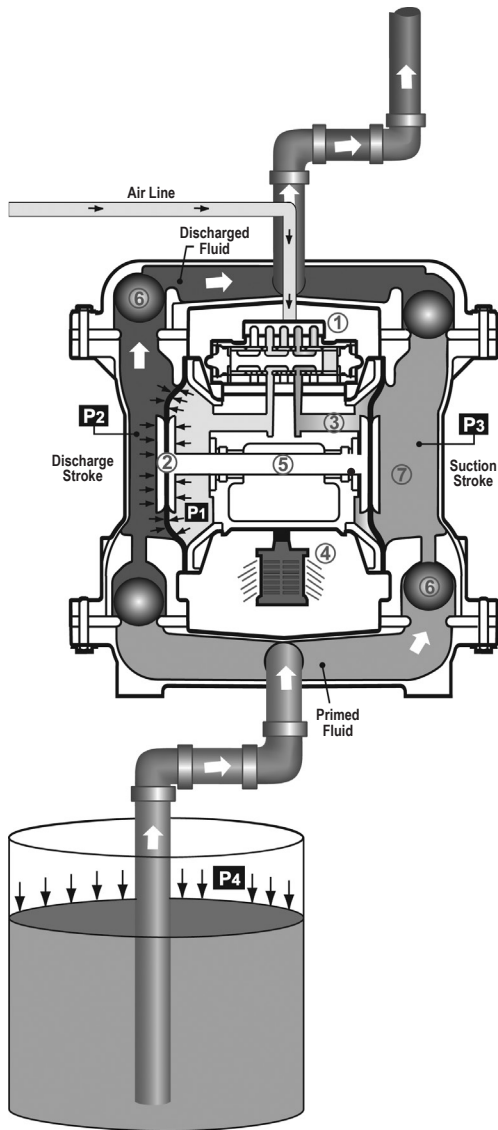

SUBMERGED ILLUSTRATION

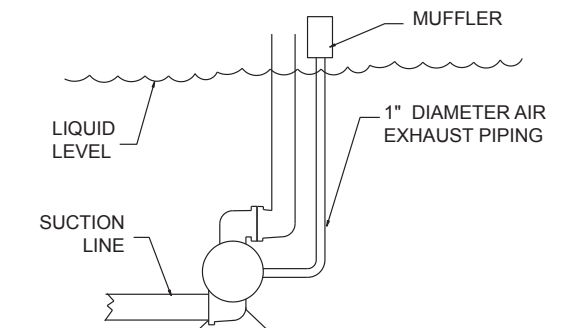

Pump can be submerged if the pump materials are compatible with the liquid being pumped. When the liquid level source is at a above the pump (flooded suction), pipe the exhaust above the liquid level to prevent siphoning spills

Principle of Pump Operation

Air Operated Double Diaphragm (AODD) pumps are powered with compressed air. A directional control valve (1) distributes compressed air to an air chamber while simultaneously exhausting the air from the opposite air chamber directed through the valve, and exhausted to atmosphere through muffer (4)

Compressed air exerts uniform pressure (P1) on the inner surface of diaphragm (2). When this pressure exceeds fluid pressure (P2), diaphragm (2) will translate to discharge the fluid. Diaphragms are connected via shaft (5) thus, as diaphragm (2) is in the discharge stroke the opposite diaphragm is the suction stroke. Liquid direction is controlled by check valves (6) and their relative orientation.

AODD pumps prime during the suction stroke. The suction stroke decreases chamber pressure (P3) by increasing chamber volume, resulting in a pressure differential. Consequently, atmospheric pressure (P4) pushes fluid through the suction piping and check valve into fluid chamber (7). The suction stroke also initiates the shifting of the pump.

As the suction diaphragm nears the end of it's stroke, the diaphragm's inner plate contacts an actuator pin which shifts the pilot signal control valve. Once actuated, the pilot valve sends a pressure signal to the opposite end of the main directional air valve, while simultaneously exhausting the other end. The main air valve redirects compressed air to the opposite air chamber and the cycle repeats.

Recommended Installation

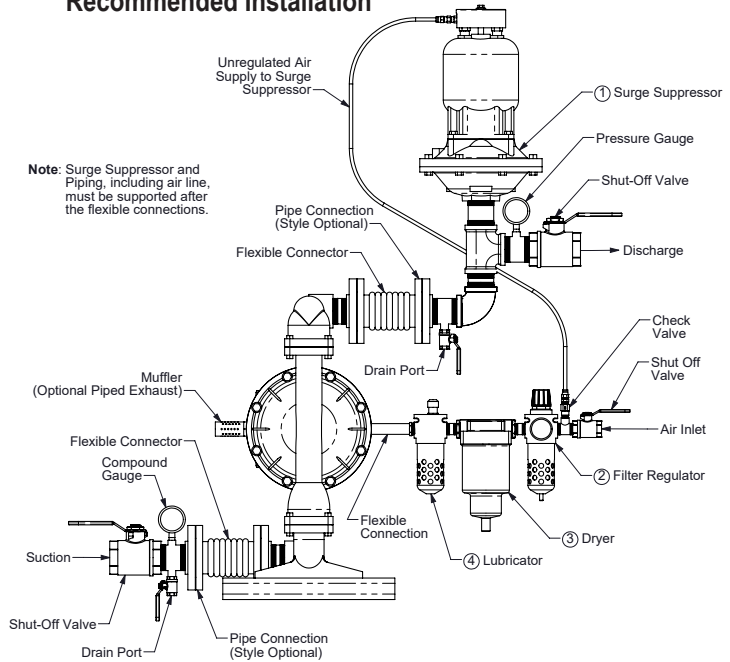

Note: Surge Suppressor and Piping, including air line, must be supported after the flexible connections.

Installation: Locate the pump as close to the product being pumped as possible. Minimize suction line length and number of fittings. Do not reduce suction line diameter.

Air Supply: Connect air supply to pump air inlet to supply sufficient capacity and pressure to achieve desired performance. Use a pressure regulator to ensure air supply pressure does not exceed recommended limits.

Air Line Moisture: Water in the air supply may cause icing or freezing of exhaust air, causing erratic pump cycling. Use a point-of-use air dryer to reduce water in air.

Air Inlet & Priming: To start the pump, slightly open air shut-off valve. After pump primes, open air shut-off valve to achieve desired flow rate. If pump cycle rate increases but liquid flow rate does not, cavitation has occurred. Slightly close the air valve to obtain efficient air flow to fluid flow ratio.

Air Valve Lubrication: The air distribution system is designed to operate without lubrication

Troubleshooting Guide

2: INSTAL & OP

Symptom:	Potential Cause(s):	Recommendation(s):
Pump Cycles Once	Deadhead (system pressure meets or exceeds air supply pressure).	Increase the inlet air pressure to the pump. Pump is designed for 1:1 pressure ratio at zero flow. (Does not apply to high pressure 2:1 units).
	Air valve or intermediate gaskets installed incorrectly.	Install gaskets with holes properly aligned.
	Bent or missing actuator plunger.	Remove pilot valve and inspect actuator plungers.
Pump Will Not Operate / Cycle	Pump is over lubricated.	Set lubricator on lowest possible setting or remove. Units are designed for lube free operation.
	Lack of air (line size, PSI, CFM).	Check the air line size and length, compressor capacity (HP vs. CFM required).
	Check air distribution system.	Disassemble and inspect main air distribution valve, pilot valve and pilot valve actuators.
	Discharge line is blocked or clogged manifolds.	Check for inadvertently closed discharge line valves. Clean discharge manifolds/piping.
	Deadhead (system pressure meets or exceeds air supply pressure).	Increase the inlet air pressure to the pump. Pump is designed for 1:1 pressure ratio at zero flow. (Does not apply to high pressure 2:1 units).
	Blocked air exhaust muffler.	Remove muffler screen, clean or de-ice, and re-install.
	Pumped fluid in air exhaust muffler.	Disassemble pump chambers. Inspect for diaphragm rupture or loose diaphragm plate assembly.
	Pump chamber is blocked.	Disassemble and inspect wetted chambers. Remove or flush any obstructions.
Pump Cycles and Will Not Prime or No Flow	Cavitation on suction side.	Check suction condition (move pump closer to product).
	Check valve obstructed. Valve ball(s) not seating properly or sticking.	Disassemble the wet end of the pump and manually dislodge obstruction in the check valve pocket. Clean out around valve ball cage and valve seat area. Replace valve ball or valve seat if damaged. Use heavier valve ball material.
	Valve ball(s) missing (pushed into chamber or manifold).	Worn valve ball or valve seat. Worn fingers in valve ball cage (replace part). Check Chemical Resistance Guide for compatibility.
	Valve ball(s) / seat(s) damaged or attacked by product.	Check Chemical Resistance Guide for compatibility.
	Check valve and/or seat is worn or needs adjusting.	Inspect check valves and seats for wear and proper setting. Replace if necessary.
	Suction line is blocked.	Remove or flush obstruction. Check and clear all suction screens or strainers.
	Excessive suction lift.	For lifts exceeding 20' of liquid, filling the chambers with liquid will prime the pump in most cases.
	Suction side air leakage or air in product.	Visually inspect all suction-side gaskets and pipe connections.
Pump Cycles Running Sluggish / Stalling, Flow Unsatisfactory	Pumped fluid in air exhaust muffler.	Disassemble pump chambers. Inspect for diaphragm rupture or loose diaphragm plate assembly.
	Over lubrication.	Set lubricator on lowest possible setting or remove. Units are designed for lube free operation.
	Icing.	Remove muffler screen, de-ice, and re-install. Install a point of use air drier.
	Clogged manifolds.	Clean manifolds to allow proper air flow.
	Deadhead (system pressure meets or exceeds air supply pressure).	Increase the inlet air pressure to the pump. Pump is designed for 1:1 pressure ratio at zero flow. (Does not apply to high pressure 2:1 units).
	Cavitation on suction side.	Check suction (move pump closer to product).
	Lack of air (line size, PSI, CFM).	Check the air line size, length, compressor capacity.
	Excessive suction lift.	For lifts exceeding 20' of liquid, filling the chambers with liquid will prime the pump in most cases.
	Air supply pressure or volume exceeds system hd.	Decrease inlet air (press. and vol.) to the pump. Pump is cavitating the fluid by fast cycling.
	Undersized suction line.	Meet or exceed pump connections.
	Restrictive or undersized air line.	Install a larger air line and connection.
	Suction side air leakage or air in product.	Visually inspect all suction-side gaskets and pipe connections.
	Suction line is blocked.	Remove or flush obstruction. Check and clear all suction screens or strainers.
	Pumped fluid in air exhaust muffler.	Disassemble pump chambers. Inspect for diaphragm rupture or loose diaphragm plate assembly.
	Check valve obstructed.	Disassemble the wet end of the pump and manually dislodge obstruction in the check valve pocket.
Check valve and/or seat is worn or needs adjusting.	Inspect check valves and seats for wear and proper setting. Replace if necessary.	
Product Leaking Through Exhaust	Entrained air or vapor lock in chamber(s).	Purge chambers through tapped chamber vent plugs. Purging the chambers of air can be dangerous.
	Diaphragm failure, or diaphragm plates loose.	Replace diaphragms, check for damage and ensure diaphragm plates are tight.
Premature Diaphragm Failure	Diaphragm stretched around center hole or bolt holes.	Check for excessive inlet pressure or air pressure. Consult Chemical Resistance Chart for compatibility with products, cleaners, temperature limitations and lubrication.
	Cavitation.	Enlarge pipe diameter on suction side of pump.
	Excessive flooded suction pressure.	Move pump closer to product. Raise pump/place pump on top of tank to reduce inlet pressure. Install Back pressure device (Tech bulletin 41r). Add accumulation tank or pulsation dampener.
	Misapplication (chemical/physical incompatibility).	Consult Chemical Resistance Chart for compatibility with products, cleaners, temperature limitations and lubrication.
Unbalanced Cycling	Incorrect diaphragm plates or plates on backwards, installed incorrectly or worn.	Check Operating Manual to check for correct part and installation. Ensure outer plates have not been worn to a sharp edge.
	Excessive suction lift.	For lifts exceeding 20' of liquid, filling the chambers with liquid will prime the pump in most cases.
	Undersized suction line.	Meet or exceed pump connections.
	Pumped fluid in air exhaust muffler.	Disassemble pump chambers. Inspect for diaphragm rupture or loose diaphragm plate assembly.
	Suction side air leakage or air in product.	Visually inspect all suction-side gaskets and pipe connections.
	Check valve obstructed.	Disassemble the wet end of the pump and manually dislodge obstruction in the check valve pocket.
	Check valve and/or seat is worn or needs adjusting.	Inspect check valves and seats for wear and proper setting. Replace if necessary.

For additional troubleshooting tips contact After Sales Support at service.warrenrupp@idexcorp.com or 419-524-8388

Material Codes - The Last 3 Digits of Part Number

Code	Description	Code	Description	Code	Description
000	Assembly, sub-assembly	332	Aluminum, Electroless Nickel Plated	540	Nylon
010	Cast Iron	333	Carbon Steel, Electroless, Nickel Plated	541	Glass Filled Nylon
015	Ductile Iron	335	Galvanized Steel	544	Nylon Injection Molded
020	Ferritic Malleable Iron	337	Silver Plated Steel	550	Polyethylene
080	Carbon Steel, AISI B-1112	350	FDA Approved Hytrel®	551	Glass Filled Polypropylene
110	316 Stainless Steel – ASTM A743 CF8M	351	Food Grade Santoprene®	552	Unfilled Polypropylene
111	316 Stainless Steel - Electro Polished	353	Geolast	555	Polyvinyl Chloride
112	Alloy C – ASTM494 CW-12M01 spec.	354	#203-40 Santoprene®	556	Black Vinyl
113	316 Stainless Steel - Hand Polished	356	Hytrel®	557	Unfilled Conductive Polypropylene
114	303 Stainless Steel	357	Injection Molded Polyurethane	558	Conductive HDPE
115	302/304 Stainless Steel	358	Urethane Rubber Compression Mold	559	Glass Filled Conductive Polypropylene
117	440-C Stainless Steel (Martensitic)	359	Urethane Rubber	570	Rulon II®
120	416 Stainless Steel - Wrought Martensitic	360	Nitrile Rubber Color coded: RED	580	Ryton®
148	Hardcoat Anodized Aluminum	363	FKM Fluorocarbon Color coded: YELLOW	600	PTFE (virgin material)
150	6061-T6 Aluminum	364	EPDM Rubber, Color coded: BLUE	603	Blue Gylon®
152	2024-T4 Aluminum (2023-T351)	365	Neoprene Rubber, Color coded: GREEN	604	PTFE
155	356-T6 Aluminum	366	Food Grade Nitrile	606	PTFE
156	356-T6 Aluminum	368	Food Grade EPDM	607	Envelon
157	Die Cast Aluminum Alloy #380	371	Philthane (Tuftane)	608	Conductive PTFE
158	Aluminum Alloy SR-319	374	Carboxylated Nitrile	610	PTFE Encapsulated Silicon
162	Brass, Yellow, Screw Machine Stock	375	Fluorinated Nitrile	611	PTFE Encapsulated FKM
165	Cast Bronze, 85-5-5-5	378	High Density Polypropylene	632	Neoprene/Hytrel®
166	Bronze, SAE 660	379	Conductive Nitrile	633	FKM/PTFE
170	Bronze, Bearing Type, Oil Impregnated	408	Cork and Neoprene	634	EPDM/PTFE
180	Copper Alloy	425	Compressed Fibre	635	Neoprene/PTFE
305	Carbon Steel, Black Epoxy Coated	426	Blue Gard	637	PTFE, FKM/PTFE
306	Carbon Steel, Black PTFE Coated	440	Vegetable Fibre	638	PTFE, Hytrel®/PTFE
307	Aluminum, Black Epoxy Coated	500	Delrin® 500	639	Nitrile/TFE
308	Stainless Steel, Black PTFE Coated	502	Conductive Acetal	643	Santoprene®/EPDM
309	Aluminum, Black PTFE Coated	503	Conductive Acetal, Glass-Filled	644	Santoprene®/PTFE
313	Aluminum, White Epoxy Coated	506	Delrin® 150	661	EPDM/Santoprene®
330	Zinc Plated Steel	520	Injection Molded PVDF	668	PTFE, FDA Santoprene® / PTFE

RECYCLING

Warren Rupp is an ISO14001 registered company and is committed to minimizing the impact our products have on the environment. Many components of SANDPIPER® AODD pumps are made of recyclable materials. We encourage pump users to recycle worn out parts and pumps whenever possible, after any hazardous pumped fluids are thoroughly flushed. Pump users that recycle will gain the satisfaction to know that their discarded part(s) or pump will not end up in a landfill. The recyclability of SANDPIPER products is a vital part of Warren Rupp's commitment to environmental stewardship.

- Delrin and Hytrel are registered tradenames of E.I. DuPont
- Nylatron is a registered tradename of Polymer Corp.
- Gylon is a registered tradename of Garlock, Inc.
- Santoprene is a registered tradename of Exxon Mobil Corp.
- Rulon II is a registered tradename of Dixon Industries Corp.

Center Section Assembly

Tools Required

- Lineman or standard pliers (air valve repair)
- Torque wrench
- 1/2" Socket
- Ratchet
- 7/32" Hex bit socket
- Phillips screwdriver

Torque Values

- Capscrews (#6).....150 in-lb
- Capscrews (#7).....150 in-lb

Center Section Assembly Servicing

- Step 1.** Remove capscrews (6) to remove inner chambers (8).
- Step 2.** Remove air inlet cap (5) by removing 4 capscrews (7).
- Step 3.** Remove gasket (10), air valve assembly (1) and gasket (9); inspect gaskets for damage and wear, replace if necessary. See next page for air valve service.
- Step 4.** Remove actuator pins (12) and o-rings (11) inspect both components for damage and wear, replace if necessary.
- Step 5.** Remove seals (15) and u-cups (14), inspect both components for damage and wear, replace if necessary.

Reinstallation

- Step 6.** Install u-cups (14) and seals (15) into intermediate (2), open end of u-cup seal (14) will face outward towards inner chamber (6)
- Step 7.** Install actuator pins (12) and o-rings (11) into intermediate, o-rings (11) will hold actuator pins (12) in place and help to align inner chambers (8) during assembly.
- Step 8.** Install inner chambers (8) using actuator pins (12) to help align. Fasten to intermediate (2) using capscrew bolts (6), torque to value given above.
- Step 9.** Place gasket (9) onto valve body (1) tabs.
- CAUTION: Ensure gasket is properly aligned to valve body (1), tabs on valve body will hold gasket in place for assembly (see figure to right).
- Step 10.** With gasket (9) on the valve body (1), slide the valve body into the intermediate (2). Align gasket (10) with tabs on air valve body (1), install air inlet cap (5) with capscrews (7), torque to value given above

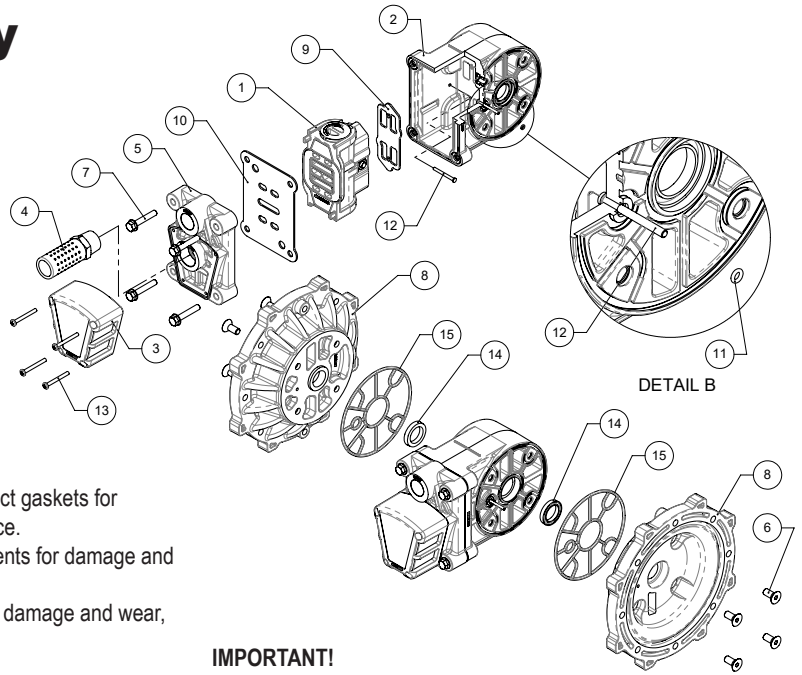

IMPORTANT!

Make sure gasket perimeter is aligned to valve body perimeter

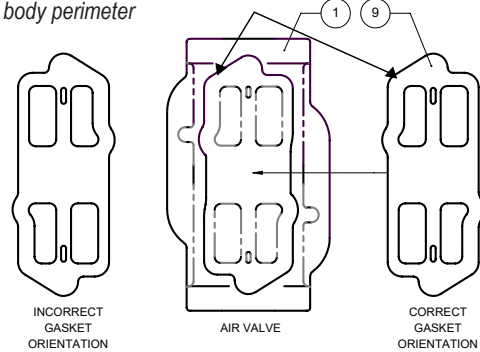

ITEM NO.	PART NUMBER	DESCRIPTION	QTY	MATERIAL	NOMENCLATURE (See Page 5)			
					P6	P11	P12	P13
1	031.218.000	Main Air Valve Assembly	1	Glass Filled Polypropylene	P			
1	031.218.001	Main Air Valve Assembly - ATEX	1	Conductive Polypropylene	C			
1	031.218.162	Stainless / Brass Main Air Valve	1	Glass Filled Polypropylene	P	0	SB	
2	114.039.551	Intermediate	1	Glass Filled Polypropylene	P			
2	114.039.559	Intermediate - ATEX	1	Conductive Polypropylene	C			
3	165.162.551	Muffler Assembly	1	Glass Filled Polypropylene	P			0
3	165.162.559	Muffler Assembly - ATEX	1	Conductive Polypropylene	C			1
4	530.058.000	Threaded Muffler (Conductive)	1	Conductive Polypropylene				6
5	165.165.551	Air Inlet Cap	1	Glass Filled Polypropylene	P			
5	165.165.559	Air Inlet Cap - ATEX	1	Conductive Polypropylene	C			
6	171.015.115	Capscrew, Flate Head, 3/8-16 x .88	8	Stainless Steel				Common
7	171.068.115	Capscrew, Flanged Hex Hd, 5/16-18 x 1.75	4	Stainless Steel				Common
8	196.224.551	Inner Chamber	2	Glass Filled Polypropylene	P			
8	196.224.559	Inner Chamber - ATEX	2	Conductive Polypropylene	C			
9	360.130.379	Air Valve Body Seal	1	Conductive Nitrile				Common
10	360.131.379	Air Inlet Cap Seal	1	Conductive Nitrile				Common
11	560.001.360	O-Ring	2	Nitrile				Common
12	620.026.114	Actuator Pins	2	Stainless Steel				Common
13	710.015.115	Screw, Self Tapping, 10-14 x 1.75	4	Stainless Steel				Common
14	720.004.360	U-Cup Seal	2	Nitrile				Common
15	720.080.360	Intermediate Seal	2	Nitrile				Common
14	720.004.360	Seal, U-Cup	2	Nitrile				Common
15	720.080.360	Seal, Intermediate	2	Nitrile				Common

6: OPTIONAL

Air / Pilot Valve Assembly

Main Air Sleeve and Spool Set

Step 1. Remove end caps (1-C). Use lineman pliers and rotate end caps 90° counter-clockwise to unlock (disengage locking tabs, see figure below). Then pull the end caps straight out of bore. Channel lock or needle nose pliers are not recommended.

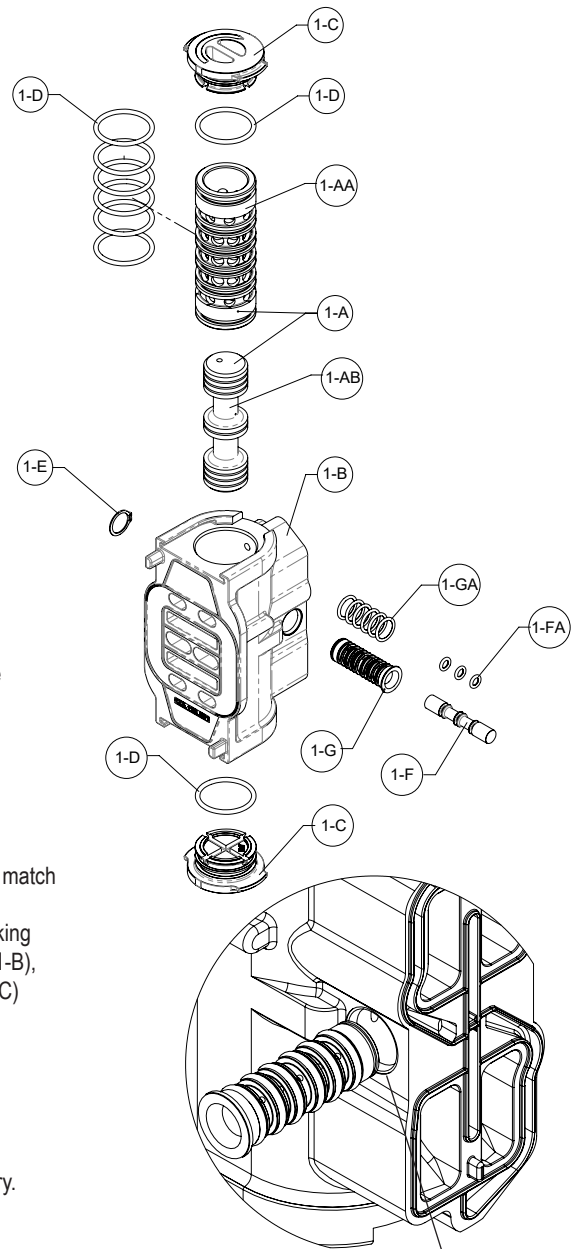
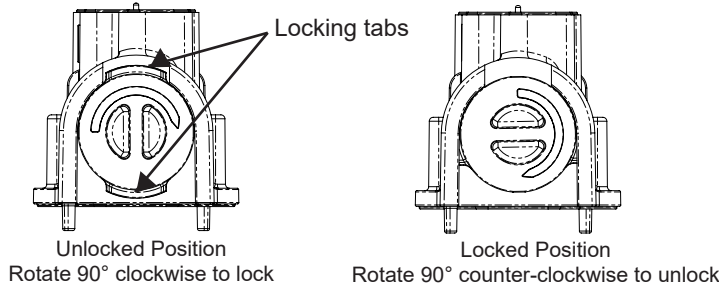

- Step 2.** Remove spool (1-AB) from sleeve (1-AA) – use caution, do not scratch spool or sleeve
Step 3. Remove sleeve (1-AA) from valve body (1-B).
Step 4. Inspect o-rings (1-D) for damage or wear, replace if necessary.

Reinstallation

- Step 5.** Install o-rings (1-D) onto sleeve (1-AA), lightly lubricate o-rings (1-D).
Step 6. Press sleeve (1-AA) into valve body (1-B).
Step 7. Carefully slide spool (1-AB) back into the sleeve (1-AA). Sleeve and spool set (1-A) is match ground to a specified clearance, they cannot be interchanged.
Step 8. Reinstall end caps (1-C). Align end caps (1-C) to the unlocked position, make sure locking tabs clear valve body (1-B) features (see figure above). Push end caps (1-C) into valve body (1-B), locking tabs should be sitting flat on valve body (1-B) surface. Using pliers, rotate end caps (1-C) clockwise 90° to engage locking tabs on end caps (1-C, see figure above).

Pilot Sleeve and Spool Set

- Step 1.** Remove retaining ring (1-E).
Step 2. Remove spool (1-F), inspect o-rings (1-FA) for damage and wear, replace if necessary.
Step 3. Remove sleeve (1-G), inspect o-rings (1-GA) for damage and wear, replace if necessary.

Reinstallation

- Step 4.** Install orings (1-FA) onto spool (1-F). Install orings (1-GA) onto sleeve (1-G). Lightly lubricate o-rings (1-FA & 1-GA).
Step 5. Locate counterbore in valve body (1-B), (see figure to right). Install pilot sleeve (1-G) in valve body (1-B) such that flange on sleeve is located within counter bore of valve body (1-B). Reinstall snap ring (1-E), slide pilot spool (1-F) into pilot sleeve (1-G).

Counterbore Location

ITEM NO.	PART NUMBER	DESCRIPTION	031.218.000/ QTY.	ATEX Rated Pumps	
				031.218.001/QTY.	031.218.162/ QTY.
1-A	031.139.000	Sleeve and Spool Set	1	1	-
1-A	031.139.162	Stainless / Brass Sleeve and Spool Set	-	-	1
1-B	095.128.551	Air Valve Body	1	-	1
1-B	095.128.559	Air Valve Body	-	1	-
1-C	165.164.541	End Cap	2	2	2
1-D	560.020.360	O-Ring	8	8	8
1-E	675.037.080	Retaining Ring	1	1	1
1-F	775.061.000	Pilot Spool Assembly, W/ O-rings	1	1	1
1-FA	560.023.360	O-Rings	3	3	3
1-G	755.052.000	Pilot Sleeve Assembly, with O-Rings	1	1	1
1-G	755.052.002	Stainless Steel Pilot Sleeve, with O-Rings	-	-	1
1-GA	560.033.360	O-Ring	6	6	6

Fluid Section Assembly

Tools Required

- Torque wrench
- ½" Socket
- Ratchet
- ½" box end wrench

Torque Values

- End ported manifolds (32 & 31) to outer chambers (25).....100 in-lb
- Manifolds (31 & 32) or Elbows (26 & 27) to outer chambers (25).....100 in-lb
- Outer Chambers (25) to inner chambers150 in-lb
- Elbows (26 & 27) to manifold (34).....150 in-lb

Manifold, check balls and outer chamber service

** Pump either equipped with end ported manifolds (31 & 32) or center ported configuration. Center ported manifolds include elbows (26 & 27) and manifold (34).

Step 1. Remove 8 capscrews (23) from discharge manifold flange, remove seats (37), seals (36) and check balls (22); inspect seals (36), seats (37) and check balls for damage and wear, replace as necessary

Step 2. Flip pump upside down 180°, remove 8 capscrews (23) from suction manifold, remove seats (37), seals (36) and check balls (22); inspect seals and check balls for damage and wear, replace as necessary

Step 3. Remove 16 capscrews (23) from outer chamber (25) flanges.

Reinstallation

Step 4. Attach outer chambers (25) using 16 capscrews (23), torque to value shown above

Step 5. Install seat seals (36), check balls (22) and seats (37) on suction side of pump. Attach suction manifold using 8 capscrews (23), torque to value shown above. Torque manifolds by torquing one side at a time (torque 4 bolts on left flange, then torque 4 remaining bolts on right flange), torque to value shown above.

Step 6. Rotate pump 180° and repeat steps 4 – 5 for the second manifold.

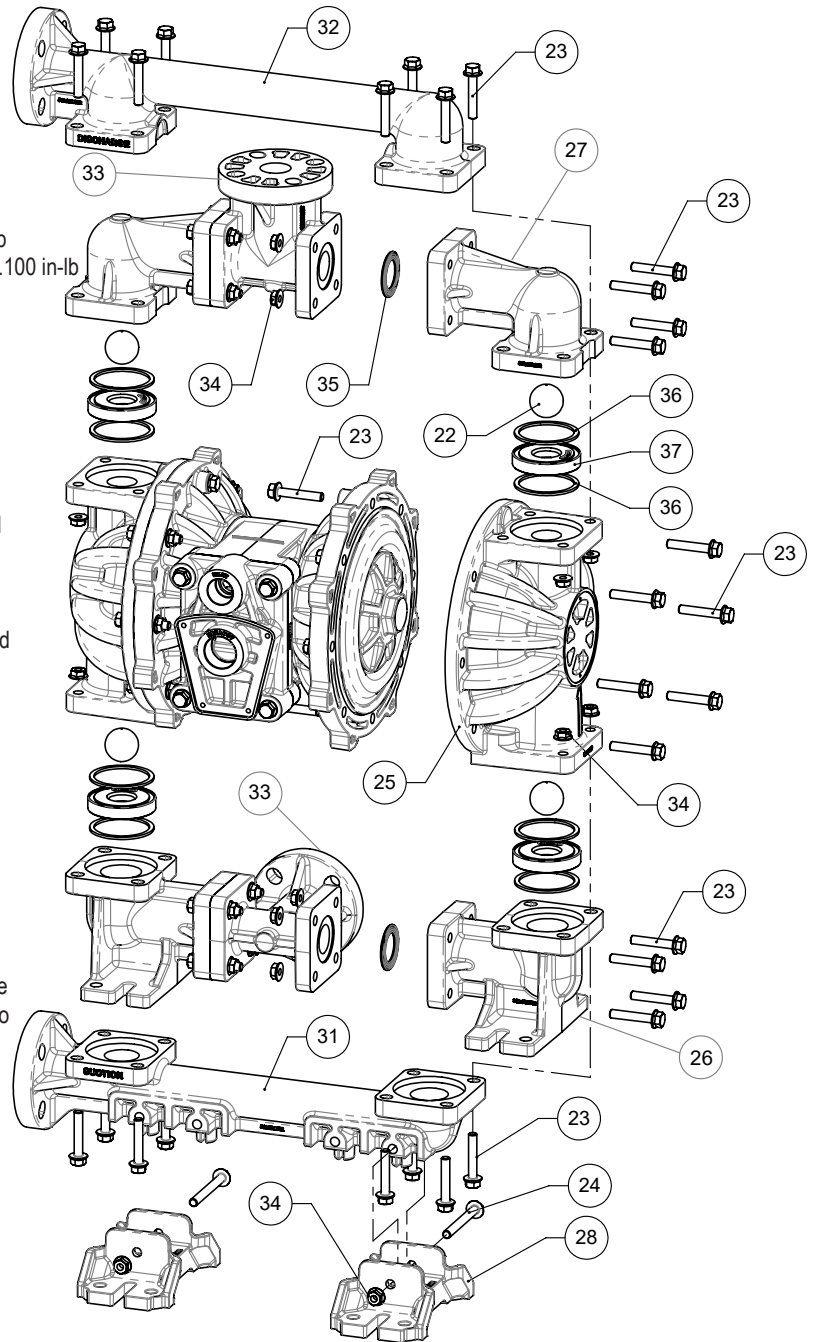

Fluid Section Assembly

ITEM NO.	PART NUMBER	DESCRIPTION	PORTING		MATERIAL	NOMENCLATURE			
			CENTER	END		(See Page 5)			
			QTY	QTY		P5	P9	P10	P15
22	050.028.354	Check Ball	4		Santoprene		R		
	050.028.360				Nitrile		B		
	050.028.365				Neoprene		N		
	050.028.600				PTFE		T		
23	171.068.115	Capscrew, Flanged Hex Hd, 5/16-18 x 1.75	48	32	Stainless Steel	Common			
24	171.070.115	Capscrew, Flanged Hex Hd, 5/16-18 x 3	-	2	Stainless Steel				E
25	196.225.552	Outer Chamber	2		Unfilled Polypropylene	P			
	196.225.557				Conductive Polypropylene	C			
	196.225.520				PVDF	K			
26	312.125.552	Suction Elbow	2	-	Unfilled Polypropylene	P			C
	312.125.557		Conductive Polypropylene	C				C	
	312.125.520		PVDF	K				C	
27	312.126.552	Discharge Elbow	2	-	Unfilled Polypropylene	P			C
	312.126.557		Conductive Polypropylene	C				C	
	312.126.520		PVDF	K				C	
28	326.055.551	Mounting Foot	-	2	Unfilled Polypropylene	P			E
	326.055.520		PVDF	K				E	
31	518.230.552	Suction Manifold	-	1	Unfilled Polypropylene	P			E
	518.230.552 N		Unfilled Polypropylene	P				E	
	518.230.552 E		Unfilled Polypropylene	P				E	
	518.230.520		PVDF	K				E	
	518.230.520 N		PVDF	K				E	
	518.230.520 E		PVDF	K				E	
32	518.231.552	Discharge Manifold	-	1	Unfilled Polypropylene	P			E
	518.231.552 N		Unfilled Polypropylene	P				E	
	518.231.552 E		Unfilled Polypropylene	P				E	
	518.231.520		PVDF	K				E	
	518.231.520 N		PVDF	K				E	
	518.231.520 E		PVDF	K				E	
33	518.232.552	Discharge Manifold	2		Unfilled Polypropylene	P			C
	518.232.552 N		Conductive Polypropylene	C				C	
	518.232.552 E								
	518.232.520								
	518.232.520 N								
	518.232.520 E								
	518.232.557		PVDF	K				C	
34	544.005.115	Nut, Hex Flange, 5/16-18	35	22	Stainless Steel	Common			
35	720.044.600	Manifold Seal	4	-	PTFE				C

6: OPTIONAL

Diaphragm Assembly

Tools Required

- Torque wrench
- 1/2" Socket
- 6 point socket, 1.375" or 35 mm
- Ratchet

Torque Values

- Outer diaphragm plate (18) to inner diaphragm plate (20)320 in-lb

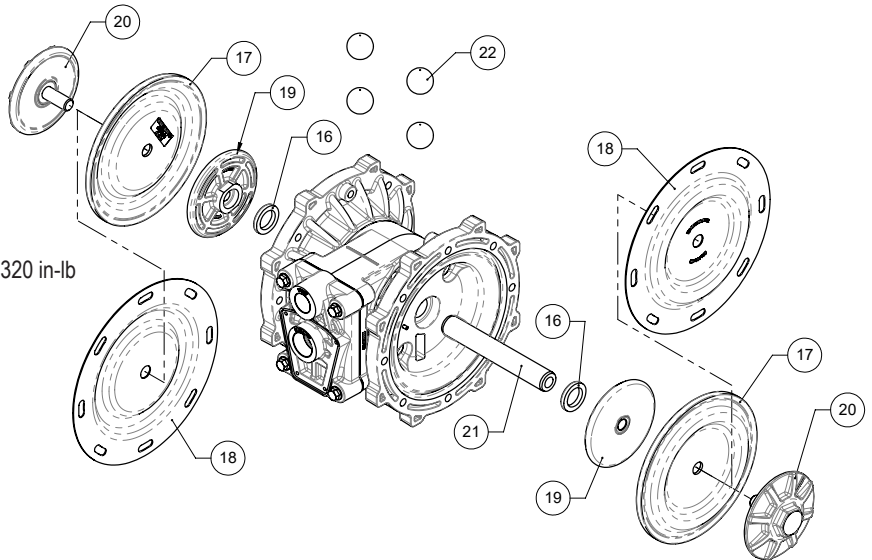

- Step 1.** With manifolds and outer chambers removed, remove outer diaphragm plate (18), diaphragm overlay (17), if equipped, diaphragm (16) and inner plate (20) from one side. NOTE: do not use pipe wrench on hex of outer diaphragm plate (18) best option: 6 point, 1.375" or 35mm socket
- Step 2.** Remove the remaining diaphragm assembly and shaft from intermediate (2). Hold diaphragm shaft (21) and remove remaining diaphragms (16) and inner and outer plates (18 & 20). NOTE: Flaws in diaphragm shaft (21) surface can damage u-cups (14), use caution, do not use pipe wrenches
- Step 3.** Inspect diaphragms (16) for wear, cracks or chemical attack. Inspect inner and outer plates (18 & 20) for deformities and wear. Inspect diaphragm shaft (21) for wear or marks. Clean or repair if appropriate, replace as required.
- Step 4.** Remove u-cup seal (14), and bumpers (19) inspect for wear, replace if necessary; clean before re-installation.

Reinstallation

- Step 5.** Lightly lubricate diaphragm contact faces of inner and outer diaphragm plates (18 & 20), with compatible material. When using PTFE overlay diaphragms, no lubrication is required on outer diaphragm plate. Water is recommended for EPDM diaphragms.
- Step 6.** Hold the inner diaphragm plate (20) by the hex with either a vise or 6 point 1.375" (35mm) socket or wrench. Locate the text "AIR SIDE" on the diaphragm (16) with air side facing the inner diaphragm plate surface. Torque outer diaphragm plate (18) to inner diaphragm plate (20), to value given above. Repeat step for second diaphragm and plate assembly.
- Step 7.** Attach 1 diaphragm assembly (from step 6) to diaphragm shaft (21), torque to specified value above. Lightly lubricate diaphragm shaft (21). Slide assembly through inner chamber holes and align diaphragm seal bead with inner chamber. With assembly installed into intermediate and inner chambers, install opposite diaphragm assembly onto diaphragm shaft (21), torque to specified value above.

ITEM NO.	PART NUMBER	DESCRIPTION	QTY	MATERIAL	P6	P8	P11	P12
16	132.140.357	Bumper	2	Urethane	COMMON			
17	286.125.350	Diaphragm	2	Hytrel	H			
	286.125.354		2	Santoprene	R	R		
	286.125.360		2	Nitrile	B			
	286.125.363		2	FKM	V			
	286.125.364		2	EPDM	E			
	286.125.365		2	Neoprene	N			
	286.127.000		2	PTFE BONDED (Includes Stud)	Z			
18	286.126.600	Diaphragm, Overlay	2	PTFE	T			
19	612.254.157	Inner Diaphragm Plate	2	Aluminum	COMMON			
	612.254.110			Stainless Steel			0	S
20	612.255.552	Plate, Outer Diaphragm	2	Polypropylene, Unfilled	P			
	612.255.520			PVDF	K			
21	685.058.120	Rod, Diaphragm	1	416 Stainless Steel	COMMON			

6: OPTIONAL

Dual Port Option

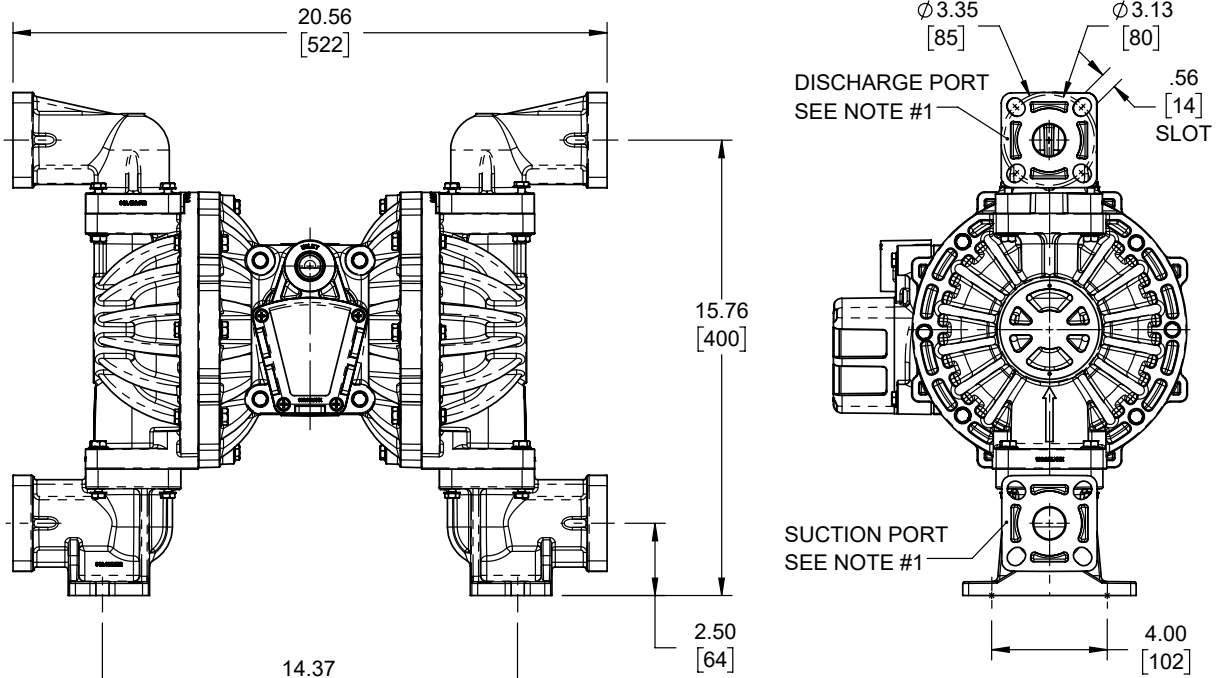

NOTES

1. SUCTION AND DISCHARGE PORT FLANGES ARE DESIGNED TO FIT BOTH ANSI 125# CONNECTION AND PN10 50mm DIN CONNECTION
2. FOR ALL OTHER DIMENSIONS REFER TO PAGE 8

Item No	Standard Elbow		Dual Porting Replacement Elbow	
26	312.125.552	Elbow, Suction	312.132.552	Polypropylene, Unfilled
	312.125.557		312.132.557	Polypropylene, Conductive
	312.125.520		312.132.520	PVDF
27	312.126.552	Elbow, Discharge	312.133.552	Polypropylene, Unfilled
	312.126.557		312.133.557	Polypropylene, Conductive
	312.126.520		312.133.520	PVDF

DUAL PORTING OPTIONS

Several dual porting options are possible. The pump can be converted to a dual port arrangement on both the suction and the discharge ends. The porting can be configured to a single suction and a dual discharge. The porting can be changed to a dual suction and a single discharge.

To convert a pump to a dual port construction the Elbows must be replaced with ones that have been modified to fit a standard 125# ANSI / DIN style 4-bolt, 1" pipe flanges. The drawing above shows the slotted hole modification.

DUAL PORTING OF BOTH SUCTION AND DISCHARGE ENDS OF THE PUMP

Converting the pump from the standard single suction and discharge porting configuration to dual porting at either manifold is easy. Simply remove the Elbows (26) and/or (27) and Manifold (33). Replace the Elbows with the appropriate material option part number from the table above.

The Dual Porting discharge and suction elbows can only be rotated at 180°. (see positioning in the Dual Porting Drawing.)

5 - YEAR Limited Product Warranty

Warren Rupp, Inc. ("Warren Rupp") warrants to the original end-use purchaser that no product sold by Warren Rupp that bears a Warren Rupp brand shall fail under normal use and service due to a defect in material or workmanship within five years from the date of shipment from Warren Rupp's factory. Warren Rupp brands include Warren Rupp®, SANDPIPER®, SANDPIPER Signature Series™, MARATHON®, Porta-Pump®, SludgeMaster™ and Tranquilizer®.

The use of non-OEM replacement parts will void (or negate) agency certifications, including CE, ATEX, CSA, 3A and EC1935 compliance (Food Contact Materials). Warren Rupp, Inc. cannot ensure nor warrant non-OEM parts to meet the stringent requirements of the certifying agencies.

~ See sandpiperpump.com/content/warranty-certifications for complete warranty, including terms and conditions, limitations and exclusions. ~



SANDPIPER®

EC Declaration of Conformity

**Manufacturer:
Warren Rupp, Inc.
800 N. Main Street
Mansfield, Ohio, 44902 USA**

Certifies that Air-Operated Double Diaphragm Pump Models: DSB Series, DMF Series, G Series, HDB Series, HDF Series, HP Series, F Series, MS Series, S Series, SL Series, SP Series, SSB Series, T Series, U1F Series, WR Series; High Pressure Pump Models: EH Series, GH Series, SH Series; Submersible Pump Models: SMA3 Series, SPA Series; and Surge Dampener/Suppressor Models: DA Series, TA Series comply with the European Community Directive 2006/42/EC on Machinery, according to Annex VIII. This product has used Harmonized Standard EN809:2012, Pumps and Pump Units for Liquids - Common Safety Requirements, to verify conformance.

October 3, 2022

DATE/APPROVAL/TITLE:

Technical File on record with:
DEKRA Certification B.V.
Meander 1051
6825 MJ Arnhem
The Netherlands

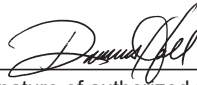

Signature of authorized person

Dennis Hall

Printed name of authorized person

Engineering Manager

Title



IBEX



CE



EC Declaration of Conformity

Manufacturer:
Warren Rupp, Inc.
800 N. Main Street
Mansfield, Ohio, 44902 USA

Certifies that Air-Operated Double Diaphragm Pump Models: DSB Series, DMF Series, G Series, HDB Series, HDF Series, HP Series, F Series, MS Series, S Series, SL Series, SP Series, SSB Series, T Series, U1F Series, WR Series; High Pressure Pump Models: EH Series, GH Series, SH Series; Submersible Pump Models: SMA3 Series, SPA Series; and Surge Dampener/Suppressor Models: DA Series, TA Series comply with the United Kingdom Statutory Instruments 2008 No. 1597, The Supply of Machinery (Safety) Regulations 2008, according to Annex VIII. This product has used Designated Standard EN809:2012, Pumps and Pump Units for Liquids - Common Safety Requirements, to verify conformance.

October 17, 2022

DATE/APPROVAL/TITLE:

Technical File on record with:
DEKRA Certification UK Limited
Stokenchurch House
Oxford Road
Stokenchurch
HP14 3SX

Signature of authorized person

Dennis Hall

Printed name of authorized person

Engineering Manager

Title

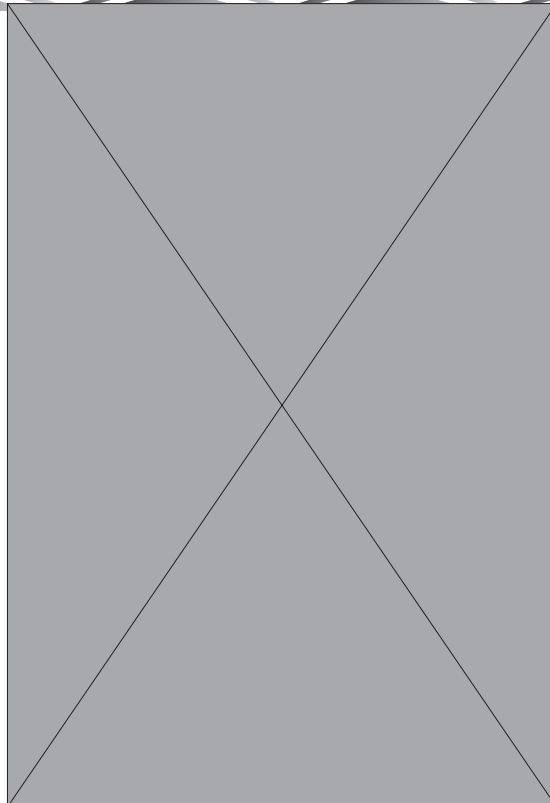



ATEX



EU Declaration of Conformity

Manufacturer:
Warren Rupp, Inc.
A Unit of IDEX Corporation
800 North Main Street
Mansfield, OH 44902 USA

This declaration of conformity is issued under the sole responsibility of the manufacturer. Warren Rupp, Inc. declares that Air Operated Double Diaphragm Pumps (AODD) and Surge Suppressors listed below comply with the requirements of Directive **2014/34/EU** and applicable harmonized standards.

Harmonized Standards:

- EN ISO 80079-36: 2016
- EN ISO 80079-37: 2016
- EN 60079-25: 2010

1. AODD Pumps and Surge Suppressors - Technical File on record with DEKRA Certification B.V.
Meander 1051
6825 MJ Arnhem
The Netherlands

Hazardous Location Applied:



II 2 G Ex h IIC T5...225°C (T2) Gb
II 2 D Ex h IIIC T100°C...T200°C Db

- Metallic pump models with external aluminum components (DMF Series, EH Series, F Series, G & GH Series, HDB Series, HDF Series, MS Series, S Series, SH Series, SL Series, SPB Series, ST Series, T Series, and U1F Series)
- Conductive plastic pump models with integral muffler (PB1/4 Series, S Series, SL Series, SPE Series)
- Tranquilizer® surge suppressors (TA Series)



II 2 G Ex h IIB T5...225°C (T2) Gb
II 2 D Ex h IIIB T100°C...T200°C Db

- ST Series with sight tubes (VL) and HP Series because of the projected area of non-conductive external components

2. AODD Pumps - EU Type Examination Certificate No.: DEKRA 18ATEX0094X - DEKRA Certification B.V. (0344)
Meander 1051
6825 MJ Arnhem
The Netherlands

Hazardous Location Applied:



I M1 Ex h I Ma
II 1 G Ex h IIC T5...225°C (T2) Ga
II 1 D Ex h IIIC T100°C...T200°C Da

- Metallic pump models with no external aluminum (HDB Series, HDF Series, G Series, S Series, SPB Series)
- Conductive plastic pumps equipped with conductive muffler (S Series, SPE Series)



II 2 G Ex h ia IIC T5 Gb
II 2 D Ex h ia IIIC T100°C Db

- Pump models with ATEX rated pulse output kit option (HDB Series, HDF Series, PB1/4, S Series, SB Series)



II 2 G Ex h mb IIC T5 Gb
II 2 D Ex h mb tb IIIC T100° Db

- Pump model series S05, S1F, S15, S20, S30 equipped with ATEX rated integral solenoid option

- > See "ATEX Details" page in user's manual for more information
- > See "Safety Information" page for conditions of safe use

DATE/APPROVAL/TITLE:
9 NOV 2023

Dennis Hall
Engineering Manager



UKEx



EU Declaration of Conformity

Manufacturer:
Warren Rupp, Inc.
A Unit of IDEX Corporation
800 North Main Street
Mansfield, OH 44902 USA

This declaration of conformity is issued under the sole responsibility of the manufacturer.
Warren Rupp, Inc declares that Air Operated Double Diaphragm Pumps (AODD) and Surge Suppressors listed below comply with the requirements of United Kingdom Statutory Instruments **2016 No. 1107** and all the applicable standards.

Designated Standards:

- EN ISO 80079-36: 2016
- EN ISO 80079-37: 2016
- EN 60079-25: 2010

1. AODD Pumps and Surge Suppressors - Technical File on record with: DEKRA Certification UK Limited
Stokenchurch House
Oxford Road
Stokenchurch
HP14 3SX

Hazardous Location Applied:



- II 2 G Ex h IIC T5...225°C (T2) Gb
- II 2 D Ex h IIIC T100°C...T200°C Db
- Metallic pump models with external aluminum components (DMF Series, EH Series, F Series, G & GH Series, HDB Series, HDF Series, MS Series, S Series, SH Series, SL Series, SPB Series, ST Series, T Series, and U1F Series)
- Conductive plastic pump models with integral muffler (PB1/4 Series, S Series, SL Series, SPE Series)
- Tranquilizer® surge suppressors (TA Series)



- II 2 G Ex h IIB T5...225°C (T2) Gb
- II 2 D Ex h IIIB T100°C...T200°C Db
- ST Series with sight tubes (VL) and HP Series because of the projected area of non-conductive external components

AUSTRALIAN DISTRIBUTOR



KelairPumps

CALL 1300 789 466

When Pump Knowledge Matters

www.kelairpumps.com.au

- > See "ATEX Details" page in user's manual for more information
- > See "Safety Information" page for conditions of safe use

DATE/APPROVAL/TITLE:
9 NOV 2023

Dennis Hall
Engineering Manager