

## FHS 100 - LM100 (IE2)

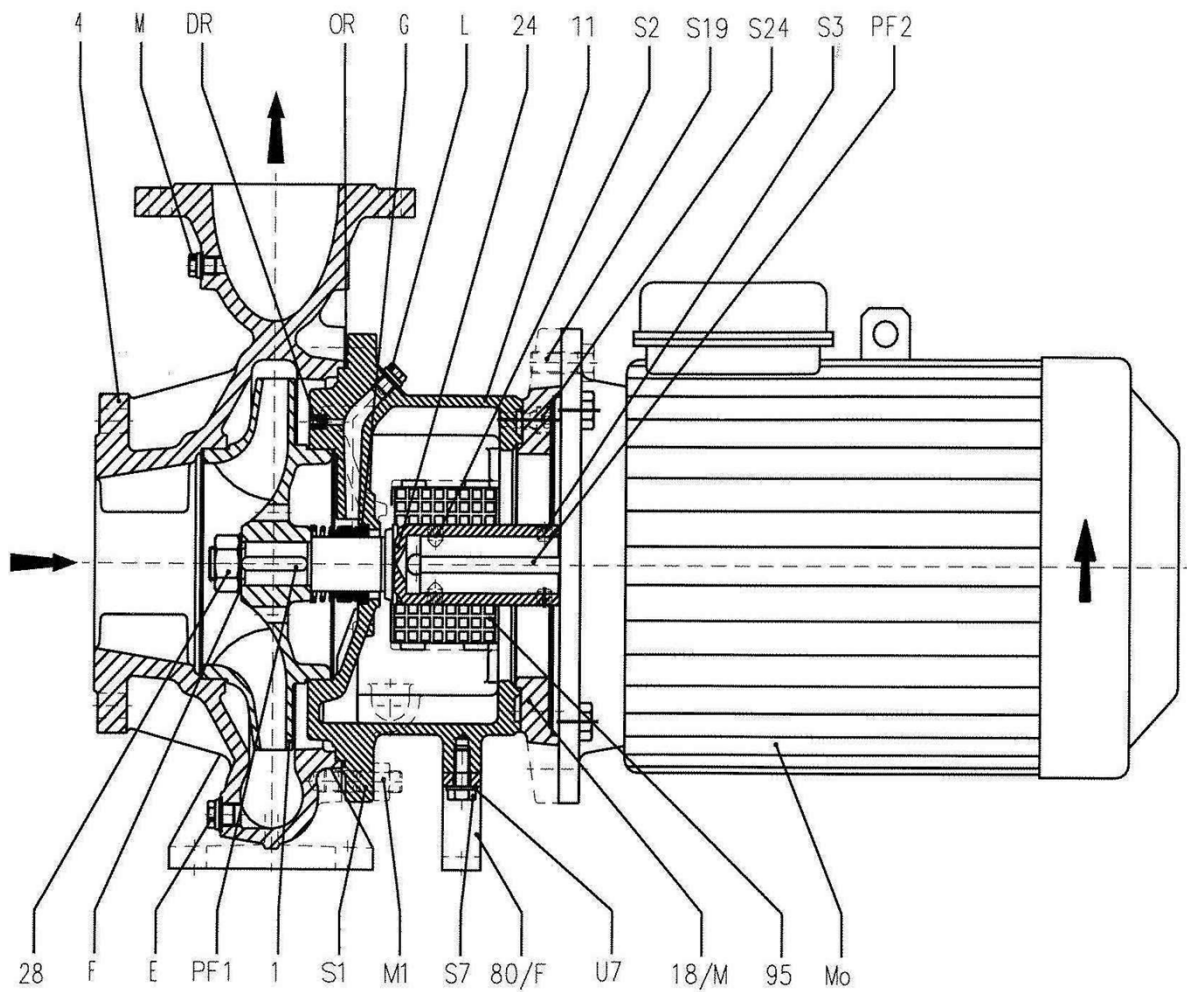

B 1130. 1A704

Casing includes plugs, and screws

Ref.	Descrizione it	Description en	Description fr	Beschreibung de	Descripción es	Descrição pt
G	Tenuta meccanica	Mechanical Seal	Garniture mécanique	Gleitringdichtung	Sello mecánico	Vedante mecânico
OR	Guarnizioni	Gaskets	Garnitures	Dichtungs	Juntas	Gaxetas
1	Girante	Impeller	Roue	Lauftrad	Impulsor	Impulsor
24	Albero, con dado girante e linguette	Shaft, with impellers nut and keys	Arbre, roue ecrou et clavettes	Welle mit Laufradmutter und Passfedern	Eje, impulsor tuerca y lenguetas	Veio, impulsor porca y linguetas
4	Corpo pompa	Pump Body	Corps de pompe	Pumpengehäuse	Caja bomba	Corpo da bomba
Mo	Motore	Motor	Moteur	Motor	Motor	Motor
Ref.	Beschrijving nl	Περιγραφή el	Açıklama tr	Kuvaus fi	Описание ru	Opis pl
G	Mechanische asafdichting	Μηχανική στεγανοποίηση	Mekanik conta	Mekaaninen tiiviste	Механическая прокладка и	Uszczelnienie mechaniczne
OR	Pakkingen	Στολίσματα	Contalar	Tiivisteeti	Уплотненияи	Uszczelki
1	Waaier	στροφέιο	Rotoru	Juoksupyörä	турбинка	Wirnik
24	Schacht waaier moer en spie	Αξονας με το καρύδι στροφείων και κλειδιά	Mil, rotorunu sabitleme takımı (somun, ve kama )	Akseli, juoksupyörän kiinnitysmutteri ja välirengas	Вал, гайка турбинки и ключи	Wal, zespół mocujący wirnika (nakrętka, i wpust )
4	Omhuysel van pomp	Πλήρες σώμα αντλίας	Pompa göndesi	Pumpun runko	Корпус насоса	Korpus pompy
Mo	Motor	Μηχανή	Motor	Motor	Мотор	Silnik

FHS\_FHBS\_65-150\_EdA\_A-desc-sc

## FHS 100 - FHBS 100

	100-160/185/1	100-160/220/1	100-160/300	100-200/300	100-200/370
FHS	703320012	703320022	703320032	703320042	703320052
FHBS	703325012	703325022	703325032	703325042	703325052
ELP 3 ~,2P ->kW	18,5	22	30	30	37
400/690V	PLM B5		W22 B5		

### Mechanical Seal, Dia. 40

* G	STD - BQ1EGG	772240107	All std version
	BQ1VGG	772240127	All other version
	Q1Q1VGG	772240146	All other version

### Pump Casing O-Ring

* OR	EPDM	772230156	100-160/185->220	All std version
	FPM	772230759	100-160/185-> 220	All other version

### Impeller

	Dia - Ø	160	165	185	192	203
* 1	FHF Cast Iron	76015004C	76015004B	760150040	76015005C	76015005A
	FHBS Bronze	76012004C	76012004B	760120040	76012005C	76012005A

### Gasket for Pump Casing

* OR	AFM34	768563080	Versions std up to 100-200/370
------	-------	-----------	--------------------------------

### Shaft with impeller nut and keys

24	FHS - FHBS	743380040	743380050	743380060	743380060	743380060
----	------------	-----------	-----------	-----------	-----------	-----------

### Pump Casing

4		743180200	100-160
	FHS - FHBS	743180210	100-200

### Motor

	Size	160	180	200L2	200L2	200L2	
Mo	P/N	50025VB00	50026VE00				Lowara Motors
				107242100	107242100	107242200	WEG Motors
				772818065	772818065	772818066	
		772818063	772818064				

WEG Motors 160/180 - On Request

Note. Motors with International Energy Efficiency Class IE2 according CE Standard 640/2009

\* Recommended spare parts - Parti di ricambio consigliate

\* Pièces détachées conseillées - Empfohlene Ersatzteile

\*\* Motor spare parts: see motor lists - Parti di ricambio motore: vedi liste motore

\*\* Pièces détachées Moteur : voir listes moteur - Motor-Ersatzteile: gem. Motorlisten

FHS\_FHBS\_65-150\_June11\_EdB

FHS 65-150 LM 65-150 (IE2)

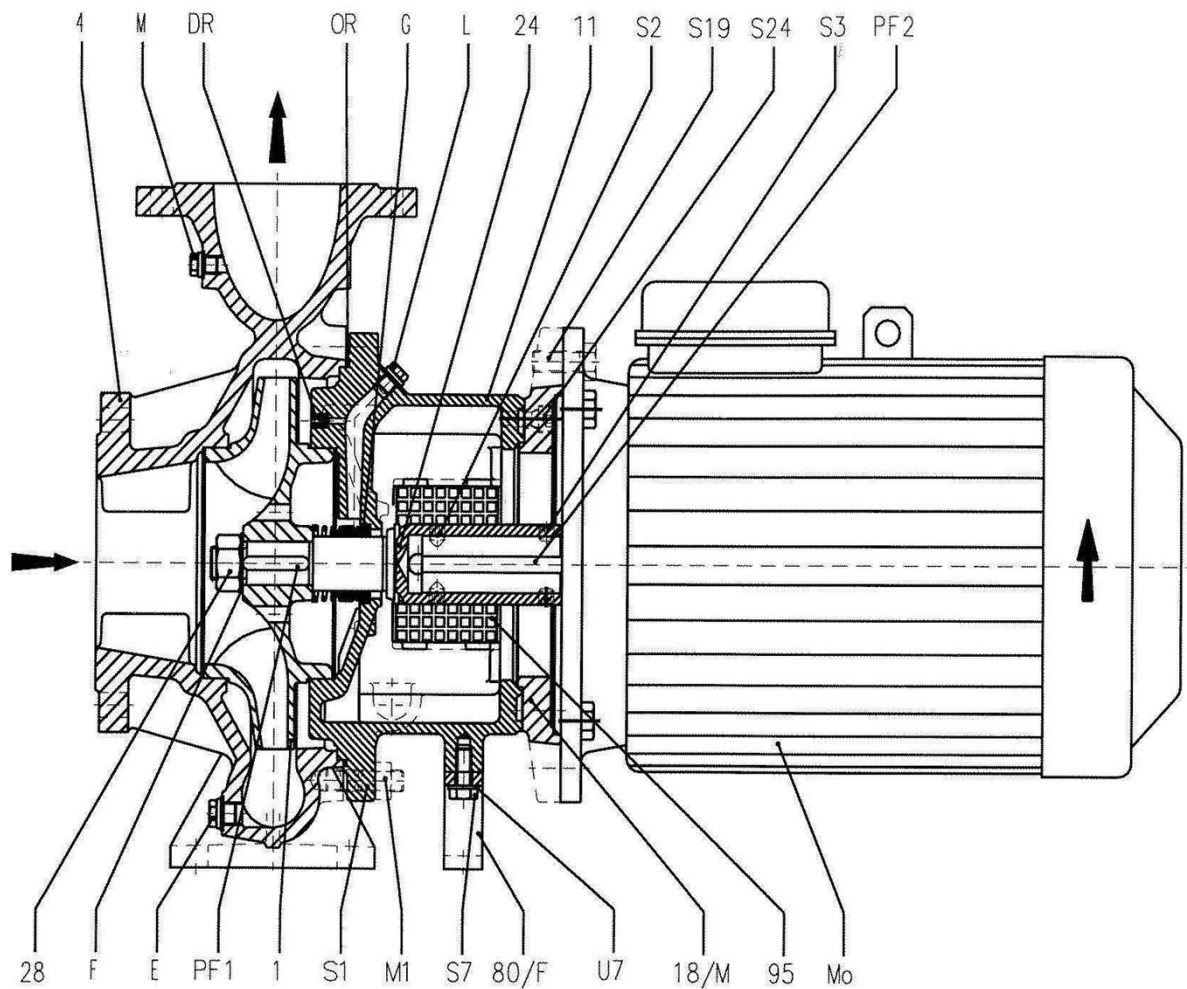

B 1130. 1A704

Casing includes plugs, and screws

Ref.	Descrizione it	Description en	Description fr	Beschreibung de	Descripción es	Descrição pt
G	Tenuta meccanica	Mechanical Seal	Garniture mécanique	Gleitringdichtung	Sello mecánico	Vedante mecânico
OR	Guarnizioni	Gaskets	Garnitures	Dichtungs	Juntas	Gaxetas
1	Girante	Impeller	Roue	Lauftrad	Impulsor	Impulsor
24	Albero, con dado girante e linguette	Shaft, with impellers nut and keys	Arbre, roue ecrou et clavettes	Welle mit Laufradmutter und Passfedern	Eje, impulsor tuerca y lenguetas	Veio, impulsor porca y linguetas
4	Corpo pompa	Pump Body	Corps de pompe	Pumpengehäuse	Caja bomba	Corpo da bomba
Mo	Motore	Motor	Moteur	Motor	Motor	Motor
Ref.	Beschrijving nl	Περιγραφή el	Açıklama tr	Kuvaus fi	Описание ru	Opis pl
G	Mechanische asafdichting	Μηχανική στεγανοποίηση	Mekanik conta	Mekaaninen tiiviste	Механическая прокладка и	Uszczelnienie mechaniczne
OR	Pakkingen	Στολίσματα	Contalar	Tiivisteeti	Уплотненияи	Uszczelki
1	Waaier	στροφέιο	Rotoru	Juoksupyörä	турбинка	Wirnik
24	Schacht waaier moer en spie	Αξονας με το καρύδι στροφείων και κλειδιά	Mil, rotorunu sabitleme takımı (somon, ve kama )	Akseli, juoksupyörän kiinnitysmutteri ja välirengas	Вал, гайка турбинки и ключи	Wal, zespół mocujący wirnika (nakrętka, i wpust)
4	Omhuysel van pomp	Πλήρες σώμα αντλίας	Pompa gövdesi	Pumpun runko	Корпус насоса	Korpus pompy
Mo	Motor	Μηχανή	Motor	Motor	Мотор	Silnik

FHS\_FHBS\_65-150\_EdA\_A-desc-sc

## FHS4 65 /P - FHBS4 65 /P

	<b>65-315/75/P</b>	<b>65-315/110/P</b>
<b>FHS4</b>	703321012	703321022
<b>FHBS4</b>	703326012	703326022
<b>ELP 3, ~ 4P -&gt;kW</b>	<b>7,5</b>	<b>11</b>
<b>400/690V</b>	PLM B5	

### Mechanical Seal, D40

* G	BQ1EGG	772240107	All std version
	BQ1VGG	772240127	All other version
	Q1Q1VGG	772240146	All other version

### Pump Casing O-Ring

* OR	STD - EPDM	772230220	All std version
	FPM	772230824	All version other

### Impeller

	Dia - Ø	283	310
* 1	FHS Cast Iron	76015001C	76015001A
	FHBS Bronze	76012001C	76012001A

### Shaft with impeller nut and keys

24	FHS - FHBS	743380030	743380040	Art. 24-28-PF
----	------------	-----------	-----------	---------------

### Pump Casing

4	FHS - FHBS	743180170	65 -315
---	------------	-----------	---------

### Motor

	Size	4-132	4-160
Mo	P/N	50021VB00	50027VB00

PLM4 5,5 - 15,0 kW with key : P/N<Y0001 ( ex. 50021VB00<Y0001 )

Note. Motors with International Energy Efficiency Class IE2 according CE Standard 640/2009

\* Recommended spare parts - Parti di ricambio consigliate

\* Pièces détachées conseillées - Empfohlene Ersatzteile

\*\* Motor spare parts: see motor lists - Parti di ricambio motore: vedi liste motore

\*\* Pièces détachées Moteur : voir listes moteur - Motor-Ersatzteile: gem. Motorlisten

## FHS4 80/P - FHBS4 80/P

	80-315/110/P	80-315/150/P
FHS4	703321032	703321042
FHBS4	703326032	703326042
ELP 3, ~ 4P ->kW	11	15
400/690V	PLM B5	

### Mechanical Seal, D40

* G	BQ1EGG	772240107	All std version
	BQ1VGG	772240127	All other version
	Q1Q1VGG	772240146	All other version

### Pump Casing O-Ring

* OR	EPDM	772230220	All std version
	FPM	772230824	All version other

### Impeller

	Dia - Ø	291	320
* 1	FHS Cast Iron	76015002C	76015002A
	FHBS Bronze	76012002C	76012002A

### Shaft with impeller nut and keys

24	FHS - FHBS	743380040	743380040	Art. 24-28-PF
----	------------	-----------	-----------	---------------

### Pump Casing

4	FHS - FHBS	743180180	80-315
---	------------	-----------	--------

### Motor

	Size	4-160	4-160
Mo	P/N	50027VB00	50028VB00

PLM4 5,5 - 15,0 kW with key : P/N<Y0001 ( ex. 50021VB00<Y0001 )

Note. Motors with International Energy Efficiency Class IE2 according CE Standard 640/2009

\* Recommended spare parts - Parti di ricambio consigliate

\* Pièces détachées conseillées - Empfohlene Ersatzteile

\*\* Motor spare parts: see motor lists - Parti di ricambio motore: vedi liste motore

\*\* Pièces détachées Moteur : voir listes moteur - Motor-Ersatzteile: gem. Motorlisten

## FHS4 100 - FHBS4 100

	100-160/30/P	100-200/40/P	100-200/55/P	100-250/75/P	100-250/110/P	100-315/150/P	100-315/185	100-315/220
FHS4	703321052	703321062	703321072	703321082	703321092	703321102	703321112	703321122
FHBS4	703326052	703326062	703326072	703326082	703326092	703326102	703326112	703326122
ELP 3, ~ 4P ->kW	3	4	5,5	7,5	11	15	18,5	22
400/690V	PLM B5						W22 B5	

### Mechanical Seal, Dia 40

* G	BQ1EGG	772240107	All std version
	BQ1VGG	772240127	All other version
	Q1Q1VGG	772240146	All other version

### Pump Casing O-Ring

* OR	EPDM	772230156	772230156	772230156	772230217	772230217	772230220	772230220	772230220	All std version
	FPM	772230759	772230759	772230759	772230821	772230821	772230824	772230824	772230824	All version other

### Impeller

	Dia - Ø	174	196	213	242	270	291	305	319
* 1	FHS Cast Iron	76015004A	76015005B	760150050	76015006C	760150060	76015007C	76015007B	76015007A
	FHBS Bronze	76012004A	76012005B	760120050	76012006C	760120060	76012007C	76012007B	76012007A

### Shaft with impeller nut and keys

24	FHS - FHBS	743380010	743380010	743380030	743380030	743380040	743380040	743380050	743380050	Art. 24-28-PF
----	------------	-----------	-----------	-----------	-----------	-----------	-----------	-----------	-----------	---------------

### Pump Casing

		100-160	100-200	100-250	100-315
4	FHS - FHBS	743180200	743380110	743180220	743180230

### Motor

	Size	4-100	4-112	4-132	4-132	4-160	4-160	180M4	100L4
Mo	P/N	50011RB00	50015VB00	50020VB00	50021VB00	50027VB00	50028VB00	772818164	772818165

PLM4 5,5 - 15,0 kW with key : P/N < Y0001 ( ex. 50021VB00 < Y0001 )

WEG motors size 160, On Request

Note. Motors with International Energy Efficiency Class IE2 according CE Standard 640/2009

\* Recommended spare parts - Parti di ricambio consigliate

\* Pièces détachées conseillées - Empfohlene Ersatzteile

\*\* Motor spare parts: see motor lists - Parti di ricambio motore: vedi liste motore

\*\* Pièces détachées Moteur : voir listes moteur - Motor-Ersatzteile: gem. Motorlisten

FHS\_FHBS\_65-150\_June11\_EdB



## FHS4 125 - FHBS4 125

	125-200/55/P	125-200/75/P	125-250/110/P	125-250/150/P	125-250/185	125-315/220	125-315/300
FHS4	703321132	703321142	703321152	703321162	703321172	703321182	703321192
FHBS4	703326132	703326142	703326152	703326162	703326172	703326182	703326192
ELP 3, ~ 4P ->kW	5,5	7,5	11	15	18,5	22	30
400/690V	PLM B5				W22 B5		

### Mechanical Seal, Dia 40

* G			
	BQ1EGG	772240107	125-250 All std version
	BQ1VGG	772240127	125-250 All other version
	Q1Q1VGG	772240146	125-250 All other version

### Mechanical Seal, Dia 50

772240110	125-200 ; 125 -315 All std version
772240131	125-200 ; 125 - 315 All other version
772240149	125-200 ; 125 - 315 All other version

### Pump Casing O-Ring

Standard

* OR									
	EPDM	772230157	772230157	772230217	772230217	772230217	-	-	Std
	FPM	772230760	772230760	772230821	772230821	772230821	-	-	Other

### Gasket for Pump Casing

* OR	AFM34	768564180	125-315	Std
------	-------	-----------	---------	-----

### Impeller

	Dia - Ø	203	224	237	257	268	292	315
* 1	FHS Cast Iron	76015009D	76015009A	76015011B	76015011A	760150110	76015012B	76015012A
	FHBS Bronze	76012009D	76012009A	76012011B	76012011A	760120110	76012012B	76012012A

### Shaft with impeller nut and keys

24	FHS - FHBS	743380070	743380070	743380040	743380040	743380050	743380090	743380100	Art. 24-28-PF
----	------------	-----------	-----------	-----------	-----------	-----------	-----------	-----------	---------------

### Pump Casing

		125-200	125-250	125-315
4	FHS - FHBS	743180250	743180260	743180280

### Motor

	Size	4-132	4-132	4-160	4-160	180M4	180L4	200L4
Mo	P/N	50020VB00	50021VB00	50027VB00	50028VB00	772818164	772818165	772818166

WEG Motors, Size 180 / 200  
PLM4 5,5 - 15,0 kW with key : P/N<Y0001 ( ex. 50021VB00<Y0001 )

Note. Motors with International Energy Efficiency Class IE2 according CE Standard 640/2009

\* Recommended spare parts - Parti di ricambio consigliate

\* Pièces détachées conseillées - Empfohlene Ersatzteile

\*\* Motor spare parts: see motor lists - Parti di ricambio motore: vedi liste motore

\*\* Pièces détachées Moteur : voir listes moteur - Motor-Ersatzteile: gem. Motorlisten

FHS\_FHBS\_65-150\_June11\_EdB

## FHS4 150 - FHBS4 150

	150-250/150/185	150-250/185	150-250/220	150-250/300	150-315/300
FHS4	703321202	703321212	703321222	703321232	703321242
FHBS4	703326202	703326212	703326222	703326232	703326242
ELP 3, ~ 4P ->kW	15	18,5	22	30	30
400/690V	PLM B5	W22 B5			

### Mechanical Seal, Dia: 50

* G	BQ1EGG	772240110	150-250 ; 150 -315 All std version
	BQ1VGG	772240131	150-250 ; 150 -315 All other version
	Q1Q1VGG	772240149	150-250 ; 150 -315 All other version

### Gasket for Pump Casing

		768563640	150-250	
* OR	AFM34	768564180	150-315	Std

### Impeller

	Dia - Ø	234	258	270	276	296
* 1	FHS Cast Iron	76015014C	76015014B	76015014A	760150140	76015015C
	FHBS Bronze	76012014C	76012014B	76012014A	760120140	76012015C

### Shaft with impeller nut and keys

24	FHS - FHBS	743380080	743380090	743380090	743380100	743380100	Art. 24-28-PF
----	------------	-----------	-----------	-----------	-----------	-----------	---------------

### Pump Casing

		150-250	150-315
4	FHS - FHBS	743180300	743180310

### Motor

	Size	4-160	180M4	180L4	200L4	200L4
Mo	P/N	50028VB00	772818164	772818165	772818166	772818166

WEG Motors, Size 180 / 200

PLM4 5,5 - 15,0 kW with key : P/N<Y0001 ( ex. 50021VB00<Y0001 )

Note. Motors with International Energy Efficiency Class IE2 according CE Standard 640/2009

\* Recommended spare parts - Parti di ricambio consigliate

\* Pièces détachées conseillées - Empfohlene Ersatzteile

\*\* Motor spare parts: see motor lists - Parti di ricambio motore: vedi liste motore

\*\* Pièces détachées Moteur : voir listes moteur - Motor-Ersatzteile: gem. Motorlisten

FHS\_FHBS\_65-150\_June11\_EdB