

SUBMERSIBLE SLUDEMATER TECHNICAL DATA SHEET

SERIES

SUBMERSIBLE CENTRIFUGAL PUMPS

Model Number: SMA3,6AM1

PERFORMANCE

CAPACITY

- 0 to 300 gallons per minute (0 to 1140 liters per minute)

AIR DISTRIBUTION VALVE

- No-lube, no-stall design

SOLIDS-HANDLING

- Up to 1.5 in. (40 mm)

MAXIMUM OPERATING PRESSURE

- 100 psi (7 bar)

MATERIAL OF CONSTRUCTION

- Wetted-Aluminum
- Non-Wetted-Aluminum

PORTING

- 3" NPT



DIMENSIONS

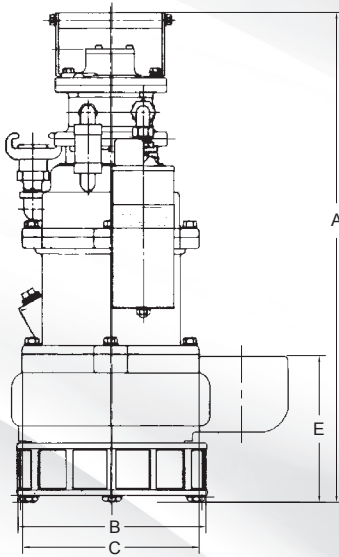

Dimensions: Tolerance $\pm 1/8"$ (± 3 mm)

A	B	C	D
Height	Width	Depth	Base To Center Discharge
23.51" (597 mm)	13" (330 mm)	9" (229 mm)	7.11" (180 mm)

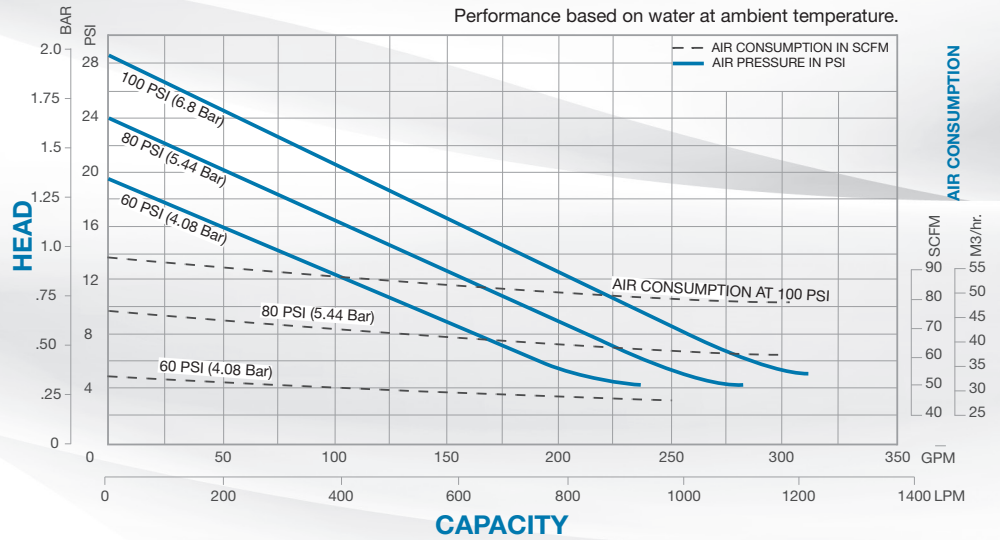

5 YEAR LIMITED PRODUCT WARRANTY

5 Year Guarantee for defects in material or workmanship. See sandpiperpump.com/content/warranty-certifications for complete warranty, including terms and conditions, limitations and exclusions.



USE ONLY GENUINE SANDPIPER PARTS

All certification, standards, guarantees & warranties originally supplied with this pump will be invalidated by the use of service parts not identified as "Genuine SANDPIPER Parts."

AUSTRALIAN DISTRIBUTOR



Warren Rupp, Inc. • A Unit of IDEX Corporation
 800 N. Main St., Mansfield, Ohio 44902 USA
 Telephone 419.524.8388 • Fax 419.522.7867



CALL 1300 789 466
 When Pump Knowledge Matters
www.kelairpumps.com.au

