

Technical Specification

90016401_1.0

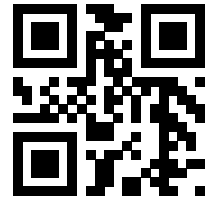

Flygt 3102

50 Hz

Table of Contents

1 D-pump.....	2
1.1 Product description.....	2
1.2 Motor rating and performance curves.....	4
2 F-pump.....	7
2.1 Product description.....	7
2.2 Motor rating and performance curves.....	9
3 M-pump.....	11
3.1 Product description.....	11
3.2 Motor rating and performance curves.....	13
4 N-pump, Standard Motor.....	16
4.1 Product description.....	16
4.2 Motor rating and performance curves.....	19
5 N-pump, Premium Efficiency Motor (IE3).....	23
5.1 Product description.....	23
5.2 Motor rating and performance curves.....	26
6 Dimensions and Weight.....	29
6.1 Drawings.....	29

1 D-pump

1.1 Product description



Usage

A submersible pump, with vortex hydraulic, for liquids containing solids and abrasive media, or light wastewater.

Denomination

Type	Non-explosion proof version	Explosion proof version	Pressure class	Installation types
Gray iron	3102.181	3102.090	<ul style="list-style-type: none"> • MT – Medium head • HT – High head 	P, X

The pump can be used in the following installations:

- P Semipermanent, wet well arrangement with the pump installed on two guide bars. The connection to the discharge is automatic.
- X Optional installation, wet or dry well arrangement without predetermined mechanical connection and with drilled flanges. Dry well arrangement requires cooling system or de-rated motor.

Application limits

Feature	Description
Liquid temperature	Maximum 40°C (104°F)
Liquid temperature, warm water version	Maximum 70°C (158°F)
Depth of immersion	Maximum 20 m (65 ft)
pH of the pumped liquid	5.5 - 14
Liquid density	Maximum 1100 kg/m ³

Motor data

Feature	Description
Motor type	Squirrel-cage induction motor
Frequency	50 Hz
Power supply	3-phase

Feature	Description
Starting method	<ul style="list-style-type: none"> • Direct on-line • Star-delta • Soft starter • Variable Frequency Drive (VFD)
Number of starts per hour	Maximum 30
Code compliance	IEC 60034-1
Voltage variation	<ul style="list-style-type: none"> • Continuously running: Maximum $\pm 5\%$ • Intermittent running: Maximum $\pm 10\%$
Voltage imbalance between phases	Maximum 2%
Stator insulation class	H (180°C, 356°F)

Motor encapsulation

Motor encapsulation is in accordance with IP68.

Cables

Application	Type
Direct-on-line start	Flygt SUBCAB® - a heavy duty 4 cores motor power cable with two twisted pair screened control cores. Conductor insulation rating of 90°C, which allows for increased current. Superior mechanical strength and high abrasion and tear resistant. Chemical resistant within pH 3-10 and ozone, oil, and flame resistant. Used up to 70°C water temperature. Cables < 10 mm ² with unscreened control cores.
Y/D start	Flygt SUBCAB® - a heavy duty 7 cores motor power cable with two twisted pair screened control cores. Conductor insulation rating of 90°C, which allows for increased current. Superior mechanical strength and high abrasion and tear resistant. Chemical resistant within pH 3-10 and ozone, oil, and flame resistant. Used up to 70°C water temperature. Cables < 7G6 mm ² with unscreened control cores.
Variable Frequency drive	Screened Flygt SUBCAB® - a heavy duty 4 screened cores motor power cable with four twisted pair screened control cores. Conductor insulation rating of 90°C, which allows for increased current. Superior mechanical strength and high abrasion and tear resistant. Chemical resistant within pH 3-10 and ozone, oil, and flame resistant. Used up to 70°C water temperature.

Monitoring equipment

Thermal contacts opening temperature 125°C (257°F)

Materials

Table 1: Major parts except mechanical seals

Denomination	Material	ASTM	EN
Major castings	Cast iron, gray	35B	GJL-250
Pump housing	Cast iron, gray	35B	GJL-250
Impeller	Cast iron, gray	35B	GJL-250
Lifting handle	Stainless steel	AISI 316L	1.4404, 1.4432, ...
Shaft	Stainless steel	AISI 431	1.4057+QT800
Screws and nuts	Stainless steel, A4	AISI 316L, 316, 316Ti	1.4401, 1.4404, ...

Denomination	Material	ASTM	EN
O-rings, alternative 1	Nitrile rubber (NBR) 70° IRH	-	-
O-rings, alternative 2	Fluorinated rubber (FPM) 70° IRH	-	-
Oil, part no 901752	Medical white oil of paraffin type. Fulfills FDA 172.878 (a)	-	-

Table 2: Mechanical seals

Alternative	Inner seal	Outer seal
1	Corrosion resistant cemented carbide (WCCR)/ Aluminum oxide (Al ₂ O ₃)	Corrosion resistant cemented carbide (WCCR)/ Aluminum oxide (Al ₂ O ₃)
2	Corrosion resistant cemented carbide (WCCR)/ Aluminum oxide (Al ₂ O ₃)	Corrosion resistant cemented carbide (WCCR)/ Corrosion resistant cemented carbide (WCCR)
3	Corrosion resistant cemented carbide (WCCR)/ Corrosion resistant cemented carbide (WCCR)	Corrosion resistant cemented carbide (WCCR)/ Aluminum oxide (Al ₂ O ₃)
4	Corrosion resistant cemented carbide (WCCR)/ Corrosion resistant cemented carbide (WCCR)	Corrosion resistant cemented carbide (WCCR)/ Corrosion resistant cemented carbide (WCCR)
5	Corrosion resistant cemented carbide (WCCR)/ Corrosion resistant cemented carbide (WCCR)	Silicon carbide (RSiC)/ Silicon carbide (RSiC)

Surface treatment

Priming	Finish
Painted with a primer, see internal standard M0700.00.0002	Navy gray color NCS 5804-B07G. Two-component high-solid top coating, see internal standard M0700.00.0004 for standard painting and M0700.00.0008 for special painting.

Options

- Warm liquid version (non-explosion proof versions)
- Leakage sensor in the stator housing (FLS)
- Leakage sensor in the oil housing (CLS)
- Surface treatment (Epoxy)
- Zinc anodes
- Other cables

Accessories

Discharge connections, adapters, hose connections, and other mechanical accessories
Electrical accessories such as pump controller, control panels, starters, monitoring relays, cables

1.2 Motor rating and performance curves

These are examples of motor rating and curves. For more information, please contact your local sales and service representative.

Star-delta starting current is 1/3 of Direct on-line starting current.

MT

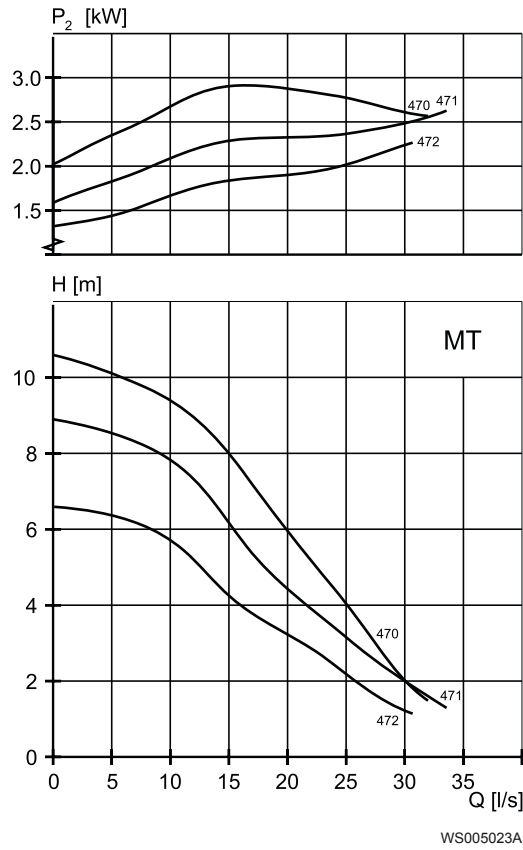

Table 3: 400 V, 50 Hz, 3-phase

Rated power, kW	Rated power, hp	Curve/ Impeller No	Revolutions per minute, rpm	Rated current, A	Starting current, A	Power factor, cos φ	Installation
3.1	4.2	470	1450	6.8	40	40	P,X
3.1	4.2	471	1450	6.8	40	40	P,X
3.1	4.2	472	1450	6.8	40	40	P,X

HT

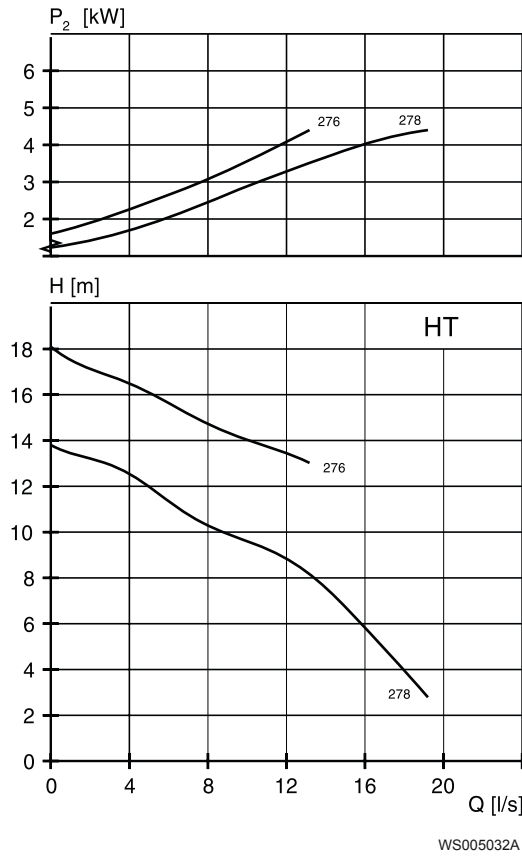

Table 4: 400 V, 50 Hz, 3-phase

Rated power, kW	Rated power, hp	Curve/ Impeller No	Revolutions per minute, rpm	Rated current, A	Starting current, A	Power factor, $\cos \varphi$	Installation
4.2	5.6	276	2900	8.2	74	0.87	P,X
4.2	5.6	276	2860	7.8	53	0.93	P,X
4.2	5.6	278	2900	8.2	74	0.87	P,X
4.2	5.6	278	2860	7.8	53	0.93	P,X

2 F-pump

2.1 Product description



Usage

A submersible pump for liquid manure, or heavily contaminated sewage and sludge. The impeller is S-shaped and has a cutting function.

Denomination

Type	Non-explosion proof version	Explosion proof version	Pressure class	Installation types
Chopper Gray iron	3102.181	3102.090	LT – Low head	P, S, X

The pump can be used in the following installations:

- P Semipermanent, wet well arrangement with the pump installed on two guide bars. The connection to the discharge is automatic.
- S Portable semipermanent, wet well arrangement with hose coupling or flange for connection to the discharge pipeline.
- X Optional installation, wet or dry well arrangement without predetermined mechanical connection and with drilled flanges. Dry well arrangement requires cooling system or de-rated motor.

Application limits

Feature	Description
Liquid temperature	Maximum 40°C (104°F)
Liquid temperature, warm water version	Maximum 70°C (158°F)
Depth of immersion	Maximum 20 m (65 ft)
pH of the pumped liquid	5.5 - 14
Liquid density	Maximum 1100 kg/m ³

Motor data

Feature	Description
Motor type	Squirrel-cage induction motor
Frequency	50 Hz
Power supply	3-phase

Feature	Description
Starting method	<ul style="list-style-type: none"> • Direct on-line • Star-delta • Soft starter • Variable Frequency Drive (VFD)
Number of starts per hour	Maximum 30
Code compliance	IEC 60034-1
Voltage variation	<ul style="list-style-type: none"> • Continuously running: Maximum $\pm 5\%$ • Intermittent running: Maximum $\pm 10\%$
Voltage imbalance between phases	Maximum 2%
Stator insulation class	H (180°C, 356°F)

Cables

Application	Type
Direct-on-line start	Flygt SUBCAB® - a heavy duty 4 cores motor power cable with two twisted pair screened control cores. Conductor insulation rating of 90°C, which allows for increased current. Superior mechanical strength and high abrasion and tear resistant. Chemical resistant within pH 3-10 and ozone, oil, and flame resistant. Used up to 70°C water temperature. Cables < 10 mm ² with unscreened control cores.
Y/D start	Flygt SUBCAB® - a heavy duty 7 cores motor power cable with two twisted pair screened control cores. Conductor insulation rating of 90°C, which allows for increased current. Superior mechanical strength and high abrasion and tear resistant. Chemical resistant within pH 3-10 and ozone, oil, and flame resistant. Used up to 70°C water temperature. Cables < 7G6 mm ² with unscreened control cores.
Variable Frequency drive	Screened Flygt SUBCAB® - a heavy duty 4 screened cores motor power cable with four twisted pair screened control cores. Conductor insulation rating of 90°C, which allows for increased current. Superior mechanical strength and high abrasion and tear resistant. Chemical resistant within pH 3-10 and ozone, oil, and flame resistant. Used up to 70°C water temperature.

Monitoring equipment

Thermal contacts opening temperature 125°C (257°F)

Materials

Table 5: Major parts except mechanical seals

Denomination	Material	ASTM	EN
Major castings	Cast iron, gray	35B	GJL-250
Pump housing	Cast iron, gray	35B	GJL-250
Impeller	Cast iron, nodular	-	GJS-400-18-LT
Suction cover	Cast iron, Hard-Iron™	A 532 IIIA	GJN-HB555(XCR23)
Lifting handle	Stainless steel	AISI 316L	1.4404, 1.4432, ...
Shaft	Stainless steel	AISI 431	1.4057+QT800
Screws and nuts	Stainless steel, A4	AISI 316L, 316, 316Ti	1.4401, 1.4404, ...
O-rings, alternative 1	Nitrile rubber (NBR) 70° IRH	-	-

Denomination	Material	ASTM	EN
O-rings, alternative 2	Fluorinated rubber (FPM) 70° IRH	-	-
Oil, part no 901752	Medical white oil of paraffin type. Fulfills FDA 172.878 (a)	-	-

Table 6: Mechanical seals

Alternative	Inner seal	Outer seal
1	Corrosion resistant cemented carbide (WCCR)/ Aluminum oxide (Al ₂ O ₃)	Corrosion resistant cemented carbide (WCCR)/ Aluminum oxide (Al ₂ O ₃)
2	Corrosion resistant cemented carbide (WCCR)/ Aluminum oxide (Al ₂ O ₃)	Corrosion resistant cemented carbide (WCCR)/ Corrosion resistant cemented carbide (WCCR)
3	Corrosion resistant cemented carbide (WCCR)/ Corrosion resistant cemented carbide (WCCR)	Corrosion resistant cemented carbide (WCCR)/ Aluminum oxide (Al ₂ O ₃)
4	Corrosion resistant cemented carbide (WCCR)/ Corrosion resistant cemented carbide (WCCR)	Corrosion resistant cemented carbide (WCCR)/ Corrosion resistant cemented carbide (WCCR)
5	Corrosion resistant cemented carbide (WCCR)/ Corrosion resistant cemented carbide (WCCR)	Silicon carbide (RSiC)/ Silicon carbide (RSiC)

Surface treatment

Priming	Finish
Painted with a primer, see internal standard M0700.00.0002	Navy gray color NCS 5804-B07G. Two-component high-solid top coating, see internal standard M0700.00.0004 for standard painting and M0700.00.0008 for special painting.

Options

- Warm liquid version (non-explosion proof versions)
- Leakage sensor in the stator housing (FLS)
- Leakage sensor in the oil housing (CLS)
- Surface treatment (Epoxy)
- Zinc anodes
- Other cables

Accessories

Discharge connections, adapters, hose connections, and other mechanical accessories
Electrical accessories such as pump controller, control panels, starters, monitoring relays, cables

2.2 Motor rating and performance curves

These are examples of motor rating and curves. For more information, please contact your local sales and service representative.

Star-delta starting current is 1/3 of Direct on-line starting current.

LT

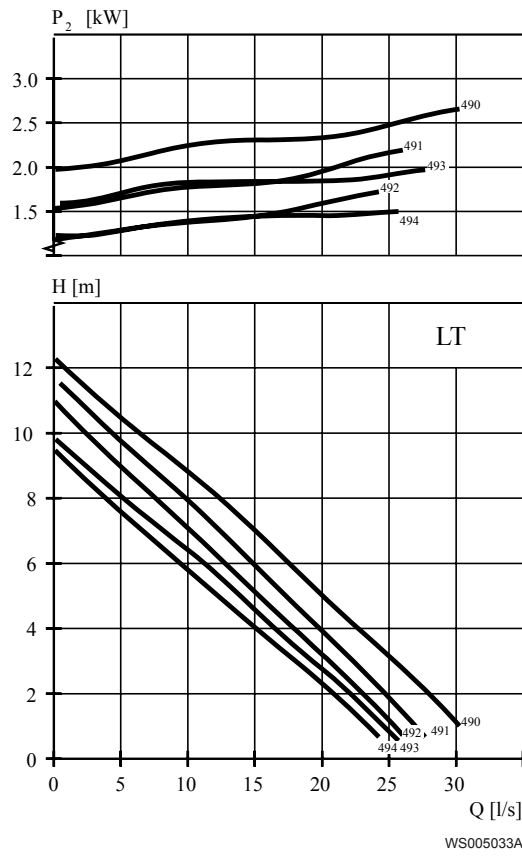

Table 7: 400 V, 50 Hz, 3-phase

Rated power, kW	Rated power, hp	Curve/ Impeller No	Revolutions per minute, rpm	Rated current, A	Starting current, A	Power factor, $\cos \varphi$	Installation
3.1	4.2	490	1450	6.8	40	0.78	P,S,X
3.1	4.2	491	1450	6.8	40	0.78	P,S,X
3.1	4.2	492	1450	6.8	40	0.78	P,S,X
3.1	4.2	493	1450	6.8	40	0.78	P,S,X
3.1	4.2	494	1450	6.8	40	0.78	P,S,X

3 M-pump

3.1 Product description



Usage

A submersible pump for wastewater containing solids that need to be macerated. The impeller is equipped with a grinder device.

Denomination

Type	Non-explosion proof version	Explosion proof version	Pressure class	Installation types
Gray iron Grinder	3102.170	3102.890	<ul style="list-style-type: none"> • LT – Low head • HT – High head 	F, P

The pump can be used in the following installations:

- F Free standing semipermanent, wet well arrangement where the pump is placed on a firm surface.
- P Semipermanent, wet well arrangement with the pump installed on two guide bars. The connection to the discharge is automatic.

Application limits

Feature	Description
Liquid temperature	Maximum 40°C (104°F)
Depth of immersion	Maximum 20 m (65 ft)
pH of the pumped liquid	5.5 - 14
Liquid density	Maximum 1100 kg/m ³

Motor data

Feature	Description
Motor type	Squirrel-cage induction motor
Frequency	50 Hz
Power supply	3-phase
Starting method	<ul style="list-style-type: none"> • Direct on-line • Star-delta • Soft starter
Number of starts per hour	Maximum 30

Feature	Description
Code compliance	IEC 60034-1
Voltage variation	<ul style="list-style-type: none"> Continuously running: Maximum $\pm 5\%$ Intermittent running: Maximum $\pm 10\%$
Voltage imbalance between phases	Maximum 2%
Stator insulation class	H (180°C, 356°F)

Cables

Application	Type
Direct-on-line start	Flygt SUBCAB® - a heavy duty 4 cores motor power cable with two twisted pair screened control cores. Conductor insulation rating of 90°C, which allows for increased current. Superior mechanical strength and high abrasion and tear resistant. Chemical resistant within pH 3-10 and ozone, oil, and flame resistant. Used up to 70°C water temperature. Cables < 10 mm ² with unscreened control cores.
Y/D start	Flygt SUBCAB® - a heavy duty 7 cores motor power cable with two twisted pair screened control cores. Conductor insulation rating of 90°C, which allows for increased current. Superior mechanical strength and high abrasion and tear resistant. Chemical resistant within pH 3-10 and ozone, oil, and flame resistant. Used up to 70°C water temperature. Cables < 7G6 mm ² with unscreened control cores.

Monitoring equipment

Thermal contacts opening temperature 125°C (257°F)

Materials

Table 8: Major parts except mechanical seals

Denomination	Material	ASTM	EN
Major castings	Cast iron, gray	35B	GJL-250
Pump housing	Cast iron, gray	35B	GJL-250
Impeller	Cast iron, gray	30B	GJL-200
Cutter wheel	Cast iron, Hard-Iron™	A 532 IIIA	GJN-HB555(XCR23)
Cutter plate	Stainless steel	-	-
Lifting handle	Stainless steel	AISI 316L	1.4404, 1.4432, ...
Shaft	Stainless steel	AISI 431	1.4057+QT800
Screws and nuts	Stainless steel, A4	AISI 316L, 316, 316Ti	1.4401, 1.4404, ...
O-rings	Nitrile rubber (NBR) 70° IRH	-	-
Oil, part no 901752	Medical white oil of paraffin type. Fulfills FDA 172.878 (a)	-	-

Table 9: Mechanical seals

Alternative	Inner seal	Outer seal
1	Corrosion resistant cemented carbide (WCCR)/ Aluminum oxide (Al ₂ O ₃)	Corrosion resistant cemented carbide (WCCR)/ Aluminum oxide (Al ₂ O ₃)
2	Corrosion resistant cemented carbide (WCCR)/ Aluminum oxide (Al ₂ O ₃)	Corrosion resistant cemented carbide (WCCR)/ Corrosion resistant cemented carbide (WCCR)

Alternative	Inner seal	Outer seal
3	Corrosion resistant cemented carbide (WCCR)/ Corrosion resistant cemented carbide (WCCR)	Corrosion resistant cemented carbide (WCCR)/ Aluminum oxide (Al ₂ O ₃)
4	Corrosion resistant cemented carbide (WCCR)/ Corrosion resistant cemented carbide (WCCR)	Corrosion resistant cemented carbide (WCCR)/ Corrosion resistant cemented carbide (WCCR)

Surface treatment

Priming	Finish
Painted with a primer, see internal standard M0700.00.0002	Navy gray color NCS 5804-B07G. Two-component high-solid top coating, see internal standard M0700.00.0004 for standard painting and M0700.00.0008 for special painting.

Options

- Leakage sensor in the stator housing (FLS)
- Leakage sensor in the oil housing (CLS)
- Surface treatment (Epoxy)
- Zinc anodes
- Other cables

Accessories

Discharge connections, adapters, hose connections, and other mechanical accessories
Electrical accessories such as pump controller, control panels, starters, monitoring relays, cables

3.2 Motor rating and performance curves

These are examples of motor rating and curves. For more information, please contact your local sales and service representative.

Star-delta starting current is 1/3 of Direct on-line starting current.

LT

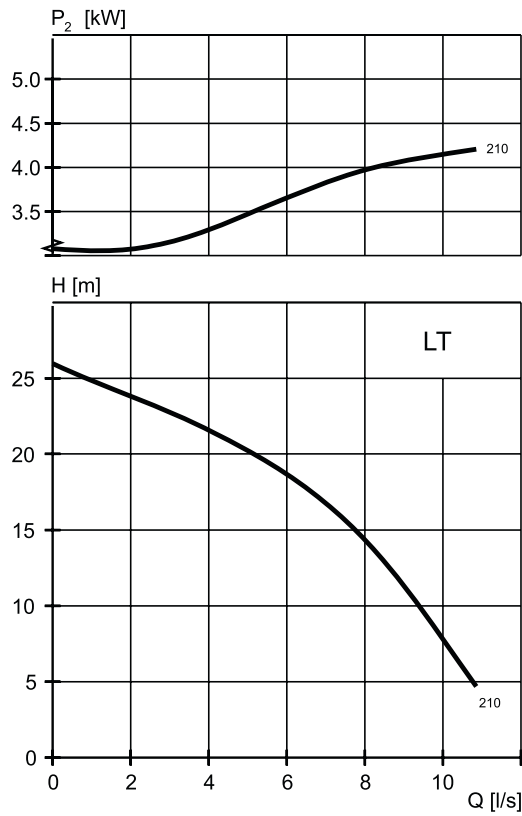

WS005036A

Table 10: 400 V, 50 Hz, 3-phase

Rated power, kW	Rated power, hp	Curve/ Impeller No	Revolutions per minute, rpm	Rated current, A	Starting current, A	Power factor, cos φ	Installation
4.4	5.9	210	2895	8.6	74	0.87	F,P
4.4	5.9	210	2855	8.2	53	0.93	F,P

HT

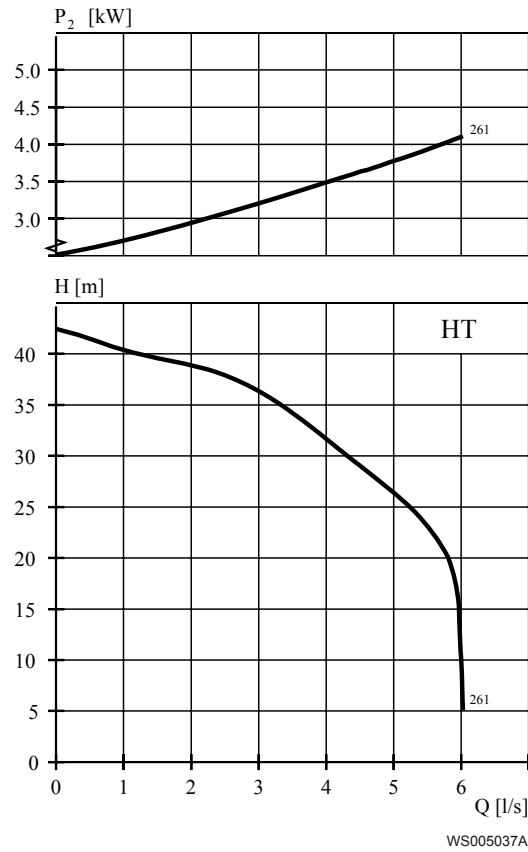

Table 11: 400 V, 50 Hz, 3-phase

Rated power, kW	Rated power, hp	Curve/ Impeller No	Revolutions per minute, rpm	Rated current, A	Starting current, A	Power factor, $\cos \varphi$	Installation
4.4	5.9	261	2895	8.6	74	0.87	F,P
4.4	5.9	261	2855	8.2	53	0.93	F,P

4 N-pump, Standard Motor

4.1 Product description



Usage

Installation type P, S, T, Z A submersible pump for efficient pumping of clean water, surface water, and wastewater containing solids or long-fibered material. The pump is designed for sustained high efficiency. For abrasive media, Hard-Iron™ is required. Stainless steel N-impeller is available as an option.

Installation type L A submersible pump for a mixed flow of clean water, surface water, or storm water. Intended for high flow and low head applications, in column installation. The pump is designed for sustained high efficiency.

Denomination

Table 12: Adaptive N-hydraulic

Impeller material	Non-explosion proof version	Explosion proof version	Pressure class	Installation types
Hard-Iron™	3102.060	3102.070	LT – Low head MT – Medium head SH – Super head	L, P, S, T, Z, X
Cast iron, gray	3102.160	3102.190	LT – Low head MT – Medium head SH – Super head	L, P, S, T, Z, X
Stainless steel	3102.760	3102.770	LT – Low head MT – Medium head SH – Super head	L, P, S, T, Z, X

The pump can be used in the following installations:

- L Vertical semipermanent, wet well column pipe arrangement where the well is divided into a suction part and a discharge part. Pump end equipped with guide vanes.
- P Semipermanent, wet well arrangement with the pump installed on two guide bars. The connection to the discharge is automatic.
- S Portable semipermanent, wet well arrangement with hose coupling or flange for connection to the discharge pipeline.

- T Vertical permanent, dry well arrangement with flange connection to the suction and discharge piping.
- Z Horizontal permanent, dry well arrangement with flange connection to the suction and discharge piping.
- X Optional installation, wet or dry well arrangement without predetermined mechanical connection and with drilled flanges. Dry well arrangement requires cooling system or de-rated motor.

Application limits

Feature	Description
Liquid temperature	Maximum 40°C (104°F)
Liquid temperature, warm water version	Maximum 70°C (158°F)
Depth of immersion	Maximum 20 m (65 ft)
pH of the pumped liquid	5.5 - 14
Liquid density	Maximum 1100 kg/m ³

Motor data

Feature	Description
Motor type	Squirrel-cage induction motor
Frequency	50 Hz
Power supply	3-phase
Starting method	<ul style="list-style-type: none"> • Direct on-line • Star-delta • Soft starter • Variable Frequency Drive (VFD)
Number of starts per hour	Maximum 30
Code compliance	IEC 60034-1
Voltage variation	<ul style="list-style-type: none"> • Continuously running: Maximum $\pm 5\%$ • Intermittent running: Maximum $\pm 10\%$
Voltage imbalance between phases	Maximum 2%
Stator insulation class	H (180°C, 356°F)

Motor encapsulation

Motor encapsulation is in accordance with IP68.

Cables

Application	Type
Direct-on-line start	Flygt SUBCAB® - a heavy duty 4 cores motor power cable with two twisted pair screened control cores. Conductor insulation rating of 90°C, which allows for increased current. Superior mechanical strength and high abrasion and tear resistant. Chemical resistant within pH 3-10 and ozone, oil, and flame resistant. Used up to 70°C water temperature. Cables < 10 mm ² with unscreened control cores.

Application	Type
Y/D start	Flygt SUBCAB® - a heavy duty 7 cores motor power cable with two twisted pair screened control cores. Conductor insulation rating of 90°C, which allows for increased current. Superior mechanical strength and high abrasion and tear resistant. Chemical resistant within pH 3-10 and ozone, oil, and flame resistant. Used up to 70°C water temperature. Cables < 7G6 mm ² with unscreened control cores.
Variable Frequency drive	Screened Flygt SUBCAB® - a heavy duty 4 screened cores motor power cable with four twisted pair screened control cores. Conductor insulation rating of 90°C, which allows for increased current. Superior mechanical strength and high abrasion and tear resistant. Chemical resistant within pH 3-10 and ozone, oil, and flame resistant. Used up to 70°C water temperature.

Monitoring equipment

Thermal contacts opening temperature 125°C (257°F)

Materials

Table 13: Major parts except mechanical seals

Denomination	Material	ASTM	EN
Major castings	Cast iron, gray	35B	GJL-250
Pump housing, alternative 1	Cast iron, gray	35B	GJL-250
Pump housing, alternative 2	Cast iron, gray	ASTM A 48 NO 30B	GJL-200
Impeller Alternative 1	Cast iron, gray	35B	GJL-250
Impeller Alternative 2	Cast iron, Hard-Iron™	A 532 IIIA	GJN-HB555(XCR23)
Impeller Alternative 3	Stainless steel, Duplex	CD-4MCuN	10283:2010 -1.4474
Insert ring Alternative 1	Cast iron, gray	35B	GJL-250
Insert ring Alternative 2	Cast iron, Hard-Iron™	A 532 IIIA	GJN-HB555(XCR23)
Lifting handle	Stainless steel	AISI 316L	1.4404, 1.4432, ...
Shaft	Stainless steel	AISI 431	1.4057+QT800
Screws and nuts	Stainless steel, A4	AISI 316L, 316, 316Ti	1.4401, 1.4404, ...
O-rings, alternative 1	Nitrile rubber (NBR) 70° IRH	-	-
O-rings, alternative 2	Fluorinated rubber (FPM) 70° IRH	-	-
Oil, part no 901752	Medical white oil of paraffin type. Fulfills FDA 172.878 (a)	-	-

Table 14: Mechanical seals

Alternative	Inner seal	Outer seal
1: 3102.060/070/170/190	Corrosion resistant cemented carbide (WCCR)/ Aluminum oxide (Al ₂ O ₃)	Corrosion resistant cemented carbide (WCCR)/ Aluminum oxide (Al ₂ O ₃)
2: 3102.060/070/170/190	Corrosion resistant cemented carbide (WCCR)/ Aluminum oxide (Al ₂ O ₃)	Corrosion resistant cemented carbide (WCCR)/ Corrosion resistant cemented carbide (WCCR)
3: 3102.060/070/170/190	Corrosion resistant cemented carbide (WCCR)/ Corrosion resistant cemented carbide (WCCR)	Corrosion resistant cemented carbide (WCCR)/ Aluminum oxide (Al ₂ O ₃)

Alternative	Inner seal	Outer seal
4	Corrosion resistant cemented carbide (WCCR)/ Corrosion resistant cemented carbide (WCCR)	Corrosion resistant cemented carbide (WCCR)/ Corrosion resistant cemented carbide (WCCR)
5	Corrosion resistant cemented carbide (WCCR)/ Corrosion resistant cemented carbide (WCCR)	Silicon carbide (RSiC)/ Silicon carbide (RSiC)
6: 3102.060/070/170/190	Carbon (CSb)/ Aluminum oxide (Al ₂ O ₃)	Corrosion resistant cemented carbide (WCCR)/ Corrosion resistant cemented carbide (WCCR)
7: 3102.0760/770	Carbon (CSb)/ Aluminum oxide (Al ₂ O ₃)	Silicon carbide (RSiC)/ Silicon carbide (RSiC)

Surface treatment

Priming	Finish
Painted with a primer, see internal standard M0700.00.0002	Navy gray color NCS 5804-B07G. Two-component high-solid top coating, see internal standard M0700.00.0004 for standard painting and M0700.00.0008 for special painting.

Options

- Warm liquid version (non-explosion proof versions)
- Leakage sensor in the stator housing (FLS)
- Leakage sensor in the oil housing (CLS)
- Surface treatment (Epoxy)
- Zinc anodes
- Other cables

Accessories

Discharge connections, adapters, hose connections, and other mechanical accessories
 Electrical accessories such as pump controller, control panels, starters, monitoring relays, cables

4.2 Motor rating and performance curves

These are examples of motor rating and curves. For more information, please contact your local sales and service representative.

Star-delta starting current is 1/3 of Direct on-line starting current.

LT

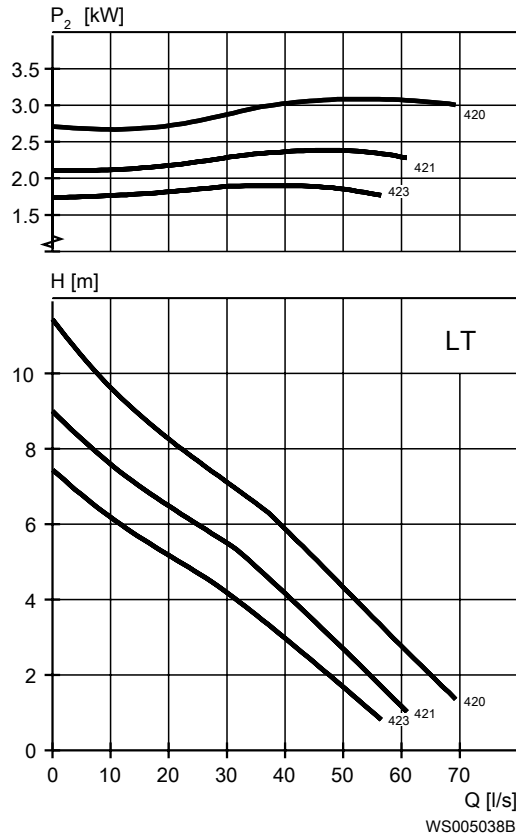

Table 15: 400 V, 50 Hz, 3-phase

Rated power, kW	Rated power, hp	Curve/ Impeller No	Revolutions per minute, rpm	Rated current, A	Starting current, A	Power factor, cos ϕ	Installation
2.4	3.2	421	1460	5.7	40	0.71	T,Z
2.4	3.2	423	1460	5.7	40	0.71	T,Z
3.1	4.2	420	1450	6.8	40	0.78	P,S,X
3.1	4.2	420	1450	6.8	40	0.78	T,Z
3.1	4.2	421	1450	6.8	40	0.78	L
3.1	4.2	421	1450	6.8	40	0.78	P,S,X
3.1	4.2	423	1450	6.8	40	0.78	L
3.1	4.2	423	1450	6.8	40	0.78	P,S,X

MT

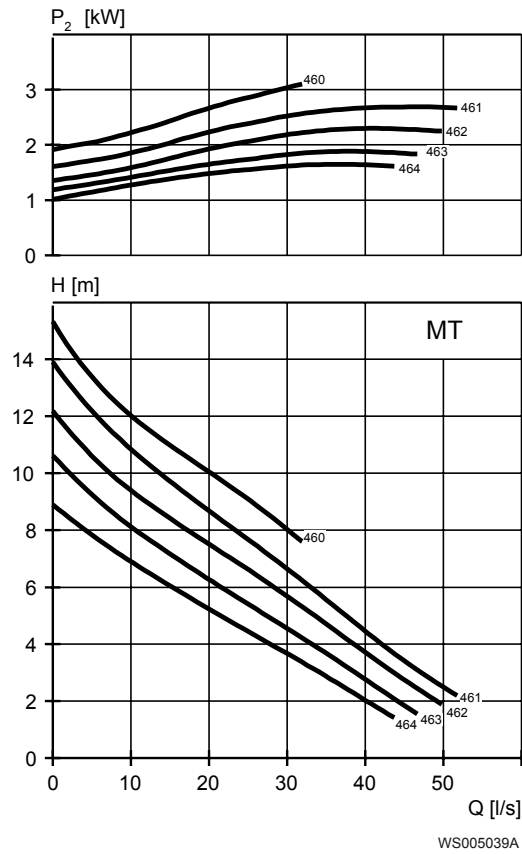

Table 16: 400 V, 50 Hz, 3-phase

Rated power, kW	Rated power, hp	Curve/ Impeller No	Revolutions per minute, rpm	Rated current, A	Starting current, A	Power factor, $\cos \varphi$	Installation
2.4	3.2	463	1460	5.7	40	0.71	T,Z
2.4	3.2	464	1460	5.7	40	0.71	T,Z
3.1	4.2	460	1450	6.8	40	0.78	T,Z
3.1	4.2	460	1450	6.8	40	0.78	P,S,X
3.1	4.2	461	1450	6.8	40	0.78	P,S,X
3.1	4.2	461	1450	6.8	40	0.78	T,Z
3.1	4.2	462	1450	6.8	40	0.78	T,Z
3.1	4.2	462	1450	6.8	40	0.78	P,S,X
3.1	4.2	463	1450	6.8	40	0.78	P,S,X
3.1	4.2	464	1450	6.8	40	0.78	P,S,X

SH

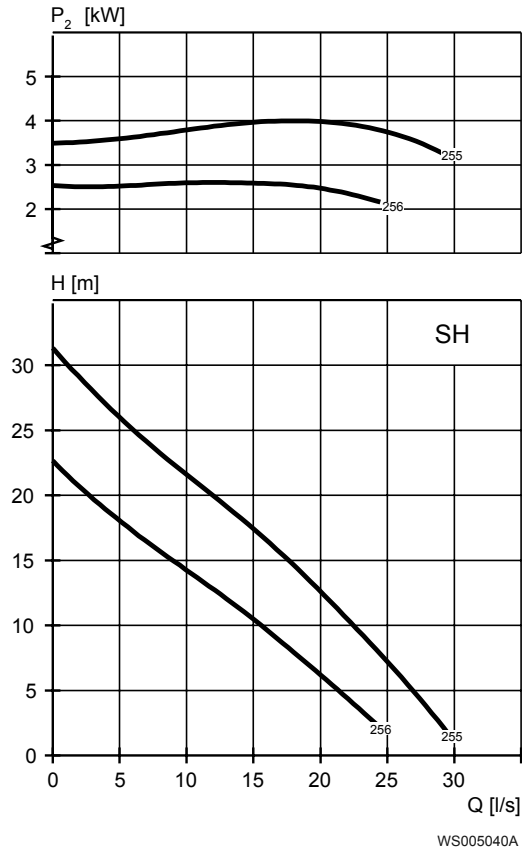

Table 17: 400 V, 50 Hz, 3-phase

Rated power, kW	Rated power, hp	Curve/ Impeller No	Revolutions per minute, rpm	Rated current, A	Starting current, A	Power factor, cos ϕ	Installation
4.2	5.6	255	2900	8.2	74	0.87	P,S,X
4.2	5.6	255	2860	7.8	53	0.93	P,S,X
4.2	5.6	255	2900	8.2	74	0.87	T,Z
4.2	5.6	255	2860	7.8	53	0.93	T,Z
4.2	5.6	256	2900	8.2	74	0.87	P,S,X
4.2	5.6	256	2860	7.8	53	0.93	P,S,X
4.2	5.6	256	2900	8.2	74	0.87	T,Z
4.2	5.6	256	2860	7.8	53	0.93	T,Z

5 N-pump, Premium Efficiency Motor (IE3)

5.1 Product description



Usage

A submersible pump for efficient pumping of clean water, surface water, and wastewater containing solids or long-fibered material. The pump is designed for sustained high efficiency. For abrasive media, Hard-Iron™ is required. Stainless steel N-impeller is available as an option.

Denomination

Table 18: Adaptive N-hydraulic

Impeller material	Non-explosion proof version	Explosion proof version	Pressure class	Installation types
Cast iron, gray	3102.900	3102.910	LT – Low head MT – Medium head SH – Super head	L, P, S, T, Z, X
Hard-Iron™	3102.920	3102.930	LT – Low head MT – Medium head SH – Super head	L, P, S, T, Z, X
Stainless steel	3102.960	3102.970	LT – Low head MT – Medium head SH – Super head	L, P, S, T, Z, X

The pump can be used in the following installations:

- L Vertical semipermanent, wet well column pipe arrangement where the well is divided into a suction part and a discharge part. Pump end equipped with guide vanes.
- P Semipermanent, wet well arrangement with the pump installed on two guide bars. The connection to the discharge is automatic.
- S Portable semipermanent, wet well arrangement with hose coupling or flange for connection to the discharge pipeline.
- T Vertical permanent, dry well arrangement with flange connection to the suction and discharge piping.

- Z Horizontal permanent, dry well arrangement with flange connection to the suction and discharge piping.
- X Optional installation, wet or dry well arrangement without predetermined mechanical connection and with drilled flanges. Dry well arrangement requires cooling system or de-rated motor.

Application limits

Feature	Description
Liquid temperature	Maximum 40°C (104°F)
Depth of immersion	Maximum 20 m (65 ft)
pH of the pumped liquid	5.5 - 14
Liquid density	Maximum 1100 kg/m ³

Motor data

Feature	Description
Motor type	Line started permanent magnet motor (LSPM)
Frequency	50 Hz
Power supply	3-phase
Starting method	<ul style="list-style-type: none"> • Direct on-line • Star-delta • Soft starter • Variable Frequency Drive (VFD)
Number of starts per hour	Maximum 30
Code compliance	IEC 60034-1
Voltage variation	<ul style="list-style-type: none"> • Continuously running: Maximum ±5% • Intermittent running: Maximum ±10%
Voltage imbalance between phases	Maximum 2%
Stator insulation class	H (180°C, 356°F)

Motor encapsulation

Motor encapsulation is in accordance with IP68.

Cables

Application	Type
Direct-on-line start	Flygt SUBCAB® - a heavy duty 4 cores motor power cable with two twisted pair screened control cores. Conductor insulation rating of 90°C, which allows for increased current. Superior mechanical strength and high abrasion and tear resistant. Chemical resistant within pH 3-10 and ozone, oil, and flame resistant. Used up to 70°C water temperature. Cables < 10 mm ² with unscreened control cores.
Y/D start	Flygt SUBCAB® - a heavy duty 7 cores motor power cable with two twisted pair screened control cores. Conductor insulation rating of 90°C, which allows for increased current. Superior mechanical strength and high abrasion and tear resistant. Chemical resistant within pH 3-10 and ozone, oil, and flame resistant. Used up to 70°C water temperature. Cables < 7G6 mm ² with unscreened control cores.

Application	Type
Variable Frequency drive	Screened Flygt SUBCAB® - a heavy duty 4 screened cores motor power cable with four twisted pair screened control cores. Conductor insulation rating of 90°C, which allows for increased current. Superior mechanical strength and high abrasion and tear resistant. Chemical resistant within pH 3-10 and ozone, oil, and flame resistant. Used up to 70°C water temperature.

Monitoring equipment

Thermal contacts opening temperature 125°C (257°F)

Materials

Table 19: Major parts except mechanical seals

Denomination	Material	ASTM	EN
Major castings	Cast iron, gray	35B	GJL-250
Pump housing, alternative 1	Cast iron, gray	35B	GJL-250
Pump housing, alternative 2	Cast iron, gray	ASTM A 48 NO 30B	GJL-200
Impeller, alternative 1	Cast iron, gray	35B	GJL-250
Impeller, alternative 2	Cast iron, Hard-Iron™	A 532 IIIA	GJN-HB555(XCR23)
Impeller, alternative 3	Stainless steel, Duplex	CD-4MCuN	10283:2010 -1.4474
Insert ring, alternative 1	Cast iron, gray	35B	GJL-250
Insert ring, alternative 2	Cast iron, Hard-Iron™	A 532 IIIA	GJN-HB555(XCR23)
Lifting handle	Stainless steel	AISI 316L	1.4404, 1.4432, ...
Shaft	Stainless steel	AISI 431	1.4057+QT800
Screws and nuts	Stainless steel, A4	AISI 316L, 316, 316Ti	1.4401, 1.4404, ...
O-rings, alternative 1	Nitrile rubber (NBR) 70° IRH	-	-
O-rings, alternative 2	Fluorinated rubber (FPM) 70° IRH	-	-
Oil, part no 901752	Medical white oil of paraffin type. Fulfills FDA 172.878 (a)	-	-

Table 20: Mechanical seals

Alternative	Inner seal	Outer seal
1	Corrosion resistant cemented carbide (WCCR)/ Aluminum oxide (Al ₂ O ₃)	Corrosion resistant cemented carbide (WCCR)/ Aluminum oxide (Al ₂ O ₃)
2	Corrosion resistant cemented carbide (WCCR)/ Aluminum oxide (Al ₂ O ₃)	Corrosion resistant cemented carbide (WCCR)/ Corrosion resistant cemented carbide (WCCR)
3	Corrosion resistant cemented carbide (WCCR)/ Corrosion resistant cemented carbide (WCCR)	Corrosion resistant cemented carbide (WCCR)/ Aluminum oxide (Al ₂ O ₃)
4	Corrosion resistant cemented carbide (WCCR)/ Corrosion resistant cemented carbide (WCCR)	Corrosion resistant cemented carbide (WCCR)/ Corrosion resistant cemented carbide (WCCR)

Surface treatment

Priming	Finish
Painted with a primer, see internal standard M0700.00.0002	Navy gray color NCS 5804-B07G. Two-component high-solid top coating, see internal standard M0700.00.0004 for standard painting and M0700.00.0008 for special painting.

Options

- Leakage sensor in the stator housing (FLS)
- Leakage sensor in the oil housing (CLS)
- Surface treatment (Epoxy)
- Zinc anodes
- Other cables

Accessories

Discharge connections, adapters, hose connections, and other mechanical accessories
 Electrical accessories such as pump controller, control panels, starters, monitoring relays, cables

5.2 Motor rating and performance curves

These are examples of motor rating and curves. For more information, please contact your local sales and service representative.

Star-delta starting current is 1/3 of Direct on-line starting current.

LT

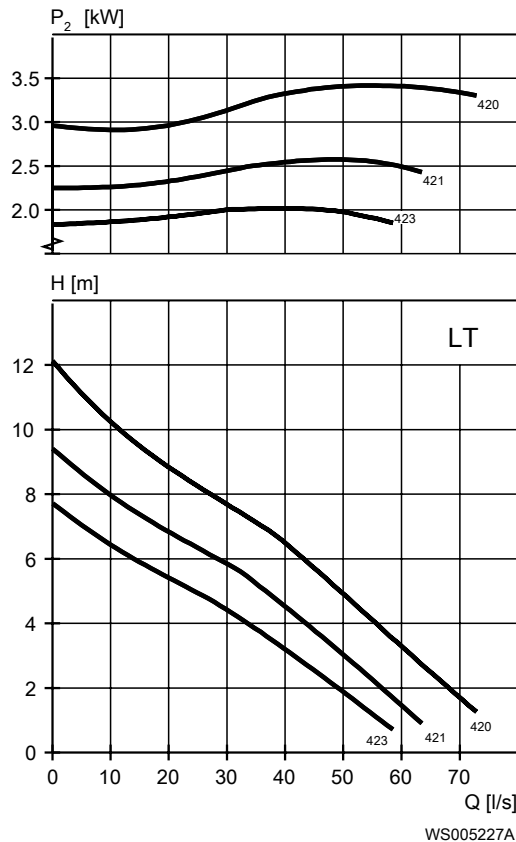

Table 21: 400 V, 50 Hz, 3-phase

Rated power, kW	Rated power, hp	Curve/ Impeller No	Revolutions per minute, rpm	Rated current, A	Starting current, A	Power factor, cos ϕ	Installation
3.5	4.7	420	1500	6.3	40	0.88	P,S,T,X,Z
3.5	4.7	421	1500	6.3	40	0.88	L
3.5	4.7	421	1500	6.3	40	0.88	P,S,T,X,Z
3.5	4.7	423	1500	6.3	40	0.88	L
3.5	4.7	423	1500	6.3	40	0.88	P,S,T,X,Z

MT

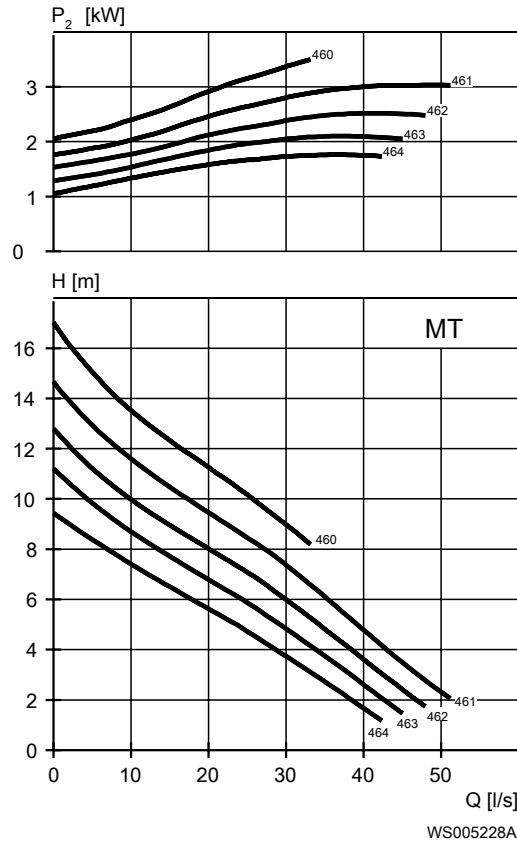

Table 22: 400 V, 50 Hz, 3-phase

Rated power, kW	Rated power, hp	Curve/ Impeller No	Revolutions per minute, rpm	Rated current, A	Starting current, A	Power factor, cos ϕ	Installation
3.5	4.7	460	1500	6.3	40	0.88	P,S,T,X,Z
3.5	4.7	461	1500	6.3	40	0.88	P,S,T,X,Z
3.5	4.7	462	1500	6.3	40	0.88	P,S,T,X,Z
3.5	4.7	463	1500	6.3	40	0.88	P,S,T,X,Z
3.5	4.7	464	1500	6.3	40	0.88	P,S,T,X,Z

SH

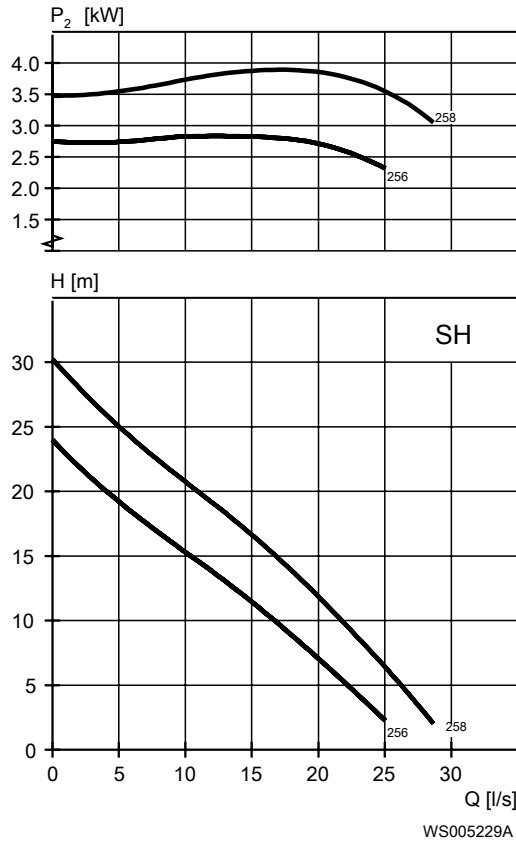

Table 23: 400 V, 50 Hz, 3-phase
IE3 compliance is based on Y-connected stator.

Rated power, kW	Rated power, hp	Curve/ Impeller No	Revolutions per minute, rpm	Rated current, A	Starting current, A	Power factor, $\cos \varphi$	Installation
4.5	6	256	3000	8.5	64	0.86	P,S,X
4.5	6	256	3000	8.5	64	0.86	T,Z
4.5	6	258	3000	8.5	64	0.86	T,Z
4.5	6	258	3000	8.5	64	0.86	P,S,X

6 Dimensions and Weight

6.1 Drawings

These drawings are included as examples.

All drawings are available as Acrobat documents (.pdf) and AutoCad drawings (.dwg).
Contact a local sales and service representative for more information.

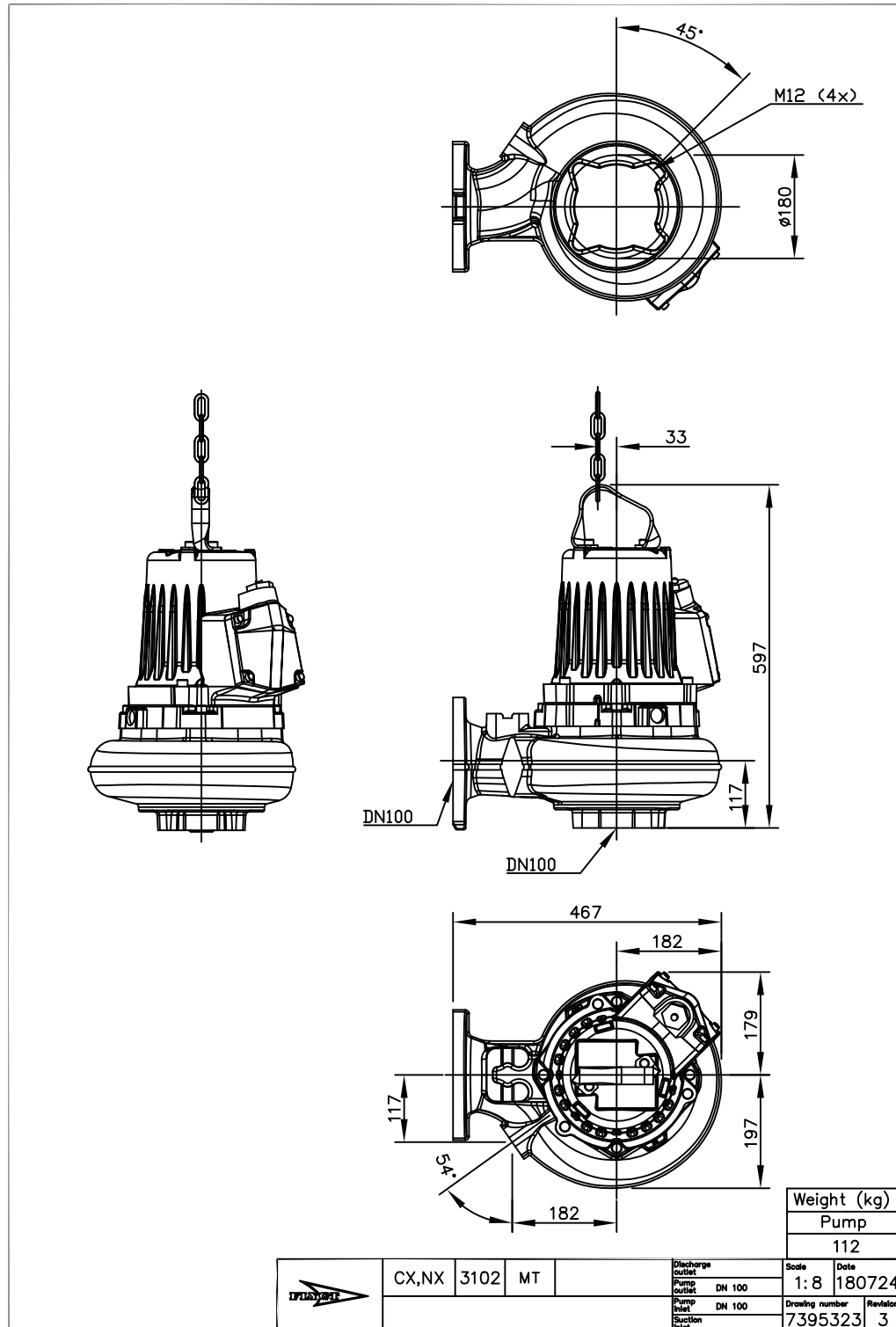

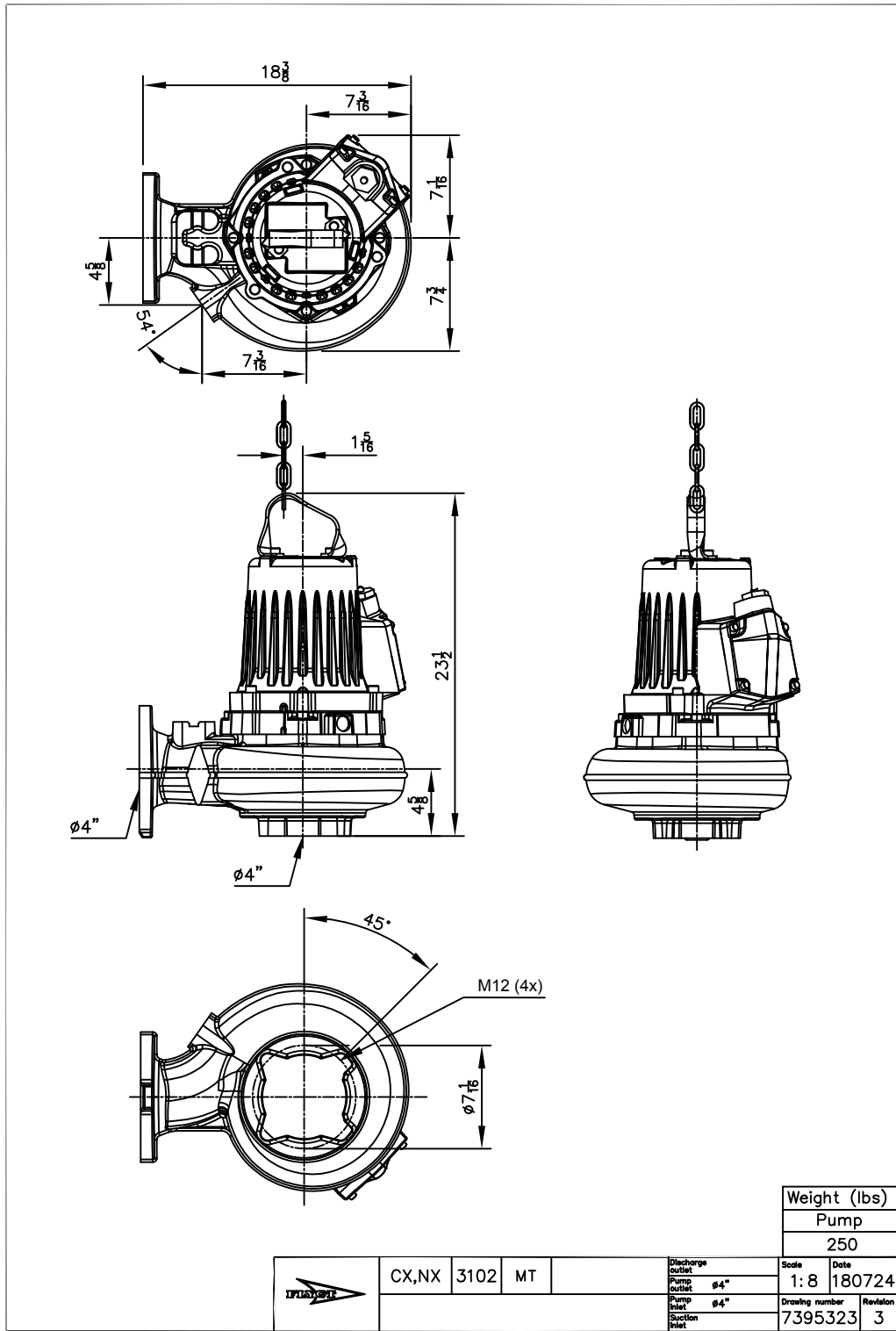

Xylem |'zīləm|

- 1) The tissue in plants that brings water upward from the roots;
- 2) a leading global water technology company.

We're a global team unified in a common purpose: creating advanced technology solutions to the world's water challenges. Developing new technologies that will improve the way water is used, conserved, and re-used in the future is central to our work. Our products and services move, treat, analyze, monitor and return water to the environment, in public utility, industrial, residential and commercial building services settings. Xylem also provides a leading portfolio of smart metering, network technologies and advanced analytics solutions for water, electric and gas utilities. In more than 150 countries, we have strong, long-standing relationships with customers who know us for our powerful combination of leading product brands and applications expertise with a strong focus on developing comprehensive, sustainable solutions.

For more information on how Xylem can help you, go to www.xylem.com

90016401_1.0_en-US_2020-01_TS_Flygt 3102/KPA/0920

AUSTRALIAN DISTRIBUTOR



CALL 1300 789 466

When Pump Knowledge Matters
www.kelairpumps.com.au