

Series Overview

Series GJ

<p>Order Code</p> <table style="width: 100%; border-collapse: collapse;"> <tr> <td style="width: 15%;">Base Code</td> <td style="width: 15%; text-align: center;">Gear Set</td> <td style="width: 15%; text-align: center;">Drive Mount</td> <td style="width: 15%; text-align: center;">Options</td> </tr> <tr> <td style="border: 1px solid black; text-align: center;">G</td> <td style="border: 1px solid black; text-align: center;">J</td> <td style="border: 1px solid black; text-align: center;">3</td> <td style="border: 1px solid black; text-align: center;">8</td> </tr> <tr> <td style="text-align: center;">1</td> <td style="text-align: center;">2</td> <td style="text-align: center;">3</td> <td style="text-align: center;">4</td> </tr> <tr> <td colspan="2" style="text-align: center;">Model</td> <td colspan="2" style="text-align: center;">Wetted Materials</td> </tr> </table> <p style="font-size: small;">O/C: Pump S/K: Service Kit</p>	Base Code	Gear Set	Drive Mount	Options	G	J	3	8	1	2	3	4	Model		Wetted Materials		<p>Pump Construction</p> <p>Magnetic Drive Gear Pump Cavity Style Two Helical, Shafted Gears/DP24 Sleeve Bushings/Gasket Seals (2) PTFE Bevel or O-Ring Seal (1) PPS Driven Magnet</p> 
Base Code	Gear Set	Drive Mount	Options														
G	J	3	8														
1	2	3	4														
Model		Wetted Materials															

Base Code Select a code character for each numbered position to configure the product.

1	Code	Product Type	Specifications	Notes		
	G	Gear Pump				
2	J	Product Series Series GJ	<i>Max System Pressure (MAWP)</i> 21 Bar (300 psi)	<i>Ports</i> 1/8-27 (F) NPT Side Ports		
3	-	Modifier Standard Design				
4		Gear Set (Width/N°Gears/Pitch)	<i>Displacement</i>	<i>Max Differential Pressure</i>	<i>Driven Magnet (Standard)</i>	
	N21	0.175/2/24	0.316 ml/rev (0.08 gal/1000*rev)	5.6 Bar (80 psi)	Ferrite	1
	N23	0.350/2/24	0.64 ml/rev (0.17 gal/1000*rev)	5.6 Bar (80 psi)	Ferrite	
	N25	0.500/2/24	0.91 ml/rev (0.24 gal/1000*rev)	5.6 Bar (80 psi)	Ferrite	
	N27	0.700/2/24	1.23 ml/rev (0.32 gal/1000*rev)	5.6 Bar (80 psi)	Ferrite	6
5		Gear Material		<i>Max Differential Pressure</i>	<i>Temp Range</i>	
	F	PTFE		3.5 Bar (50 psi)	-46/99°C (-50/210°F)	2
	P	PPS (carbon fiber/ptfe)		5.2 Bar (75 psi)	-46/121°C (-50/250°F)	
	J	PEEK (carbon fiber/ptfe)		5.6 Bar (80 psi)	-46/121°C (-50/250°F)	
6		Static Seals			<i>Temp Range</i>	
	F1	PTFE Gasket (.004) 5369			-46/54°C (-50/130°F)	3
	F2	PTFE Gasket (.005) 3613			43/77°C (110/170°F)	
	F3	PTFE Gasket (.006) 4188			71/99°C (160/210°F)	
	V	Viton®			-29/121°C (-20/250°F)	
	F11	PTFE Gaskets/Viton O-Ring			-46/54°C (-50/130°F)	
	F12	PTFE Gaskets/EP O-Ring			-46/54°C (-50/130°F)	
7		Base Materials				
	S	SS316				
	D	Alloy 20				
	T	Titanium				
	C	Hast C-276®				
8		Drive Mount	<i>Max System Pressure (MAWP)</i>		<i>Weight (Pumphead)</i>	
	A	MP Housing	21 Bar (300 psi)		0.34 kg (0.75 lbs)	
	B	MP Plate	21 Bar (300 psi)		0.34 kg (0.75 lbs)	
	M	I-Drive™ IMS	21 Bar(300 psi) SS316		0.45 kg (1.0 lbs)	
	J	I-Drive™ IEG	21 Bar(300 psi) SS316		0.45 kg (1.0 lbs)	
	E	NEMA 56C	21 Bar (300 psi)		1.2 kg (2.6 lbs)	
	6	IEC 71-B14	21 Bar (300 psi)		1.2 kg (2.6 lbs)	

Series Overview

Series GJ

Order Code								Pump Construction	
Base Code		Gear Set		Drive Mount		Options		Magnetic Drive Gear Pump Cavity Style Two Helical, Shafted Gears/DP24 Sleeve Bushings/Gasket Seals (2) PTFE Bevel or O-Ring Seal (1) PPS Driven Magnet	
G	J								
1	2	3	4	5	6	7	8		
Model			Wetted Materials			O/C: Pump S/K: Service Kit			

Options Add Option codes after the Base Code to modify features or enhance the product.

Bypass (PC11)		Optional Internal Bypass		
B1	Internal Bypass (SS316)	Preset to 3 Bar (G drive to 5.4 bar)		4
Driven Magnet (PC12)				
M3	NdFeB Driven (Ring)			
Driving Magnet (PC13)				
N3	NdFeB Driving (Ring)			5
Ports/Fittings (PC17)		Ports	Ports	
P4	1/4-18 NPT Ports	1/8-27 (F) NPT Side Ports		

Notes

- 1 N21 gear set ordered in PTFE gear material, order only F2 or F3 static seal
- 2 PTFE gear material ordered in N21 gear set, order only F2 or F3 static seal
- 3 Do not order F1 seals if ordering N21 gear set in PTFE gear material
- 4 Available in SS316 only
- 5 Available only with industrial IEC or NEMA drive mounts
- 6 N27 gear set only offered in PEEK and PPS gear materials

Order Code				Pump Construction			
Base Code		Gear - Set		Drive Mount		Options	
G	J	-	N21				
1	2	3	4	5	6	7	8
Model				Wetted Materials			
				O/C: Pump S/K: Service Kit			
				Magnetic Drive Gear Pump Cavity Style Two Helical, Shafted Gears/DP24 Sleeve Bushings/Gasket Seals (2) PTFE Bevel or O-Ring Seal (1) PPS Driven Magnet			



Performance

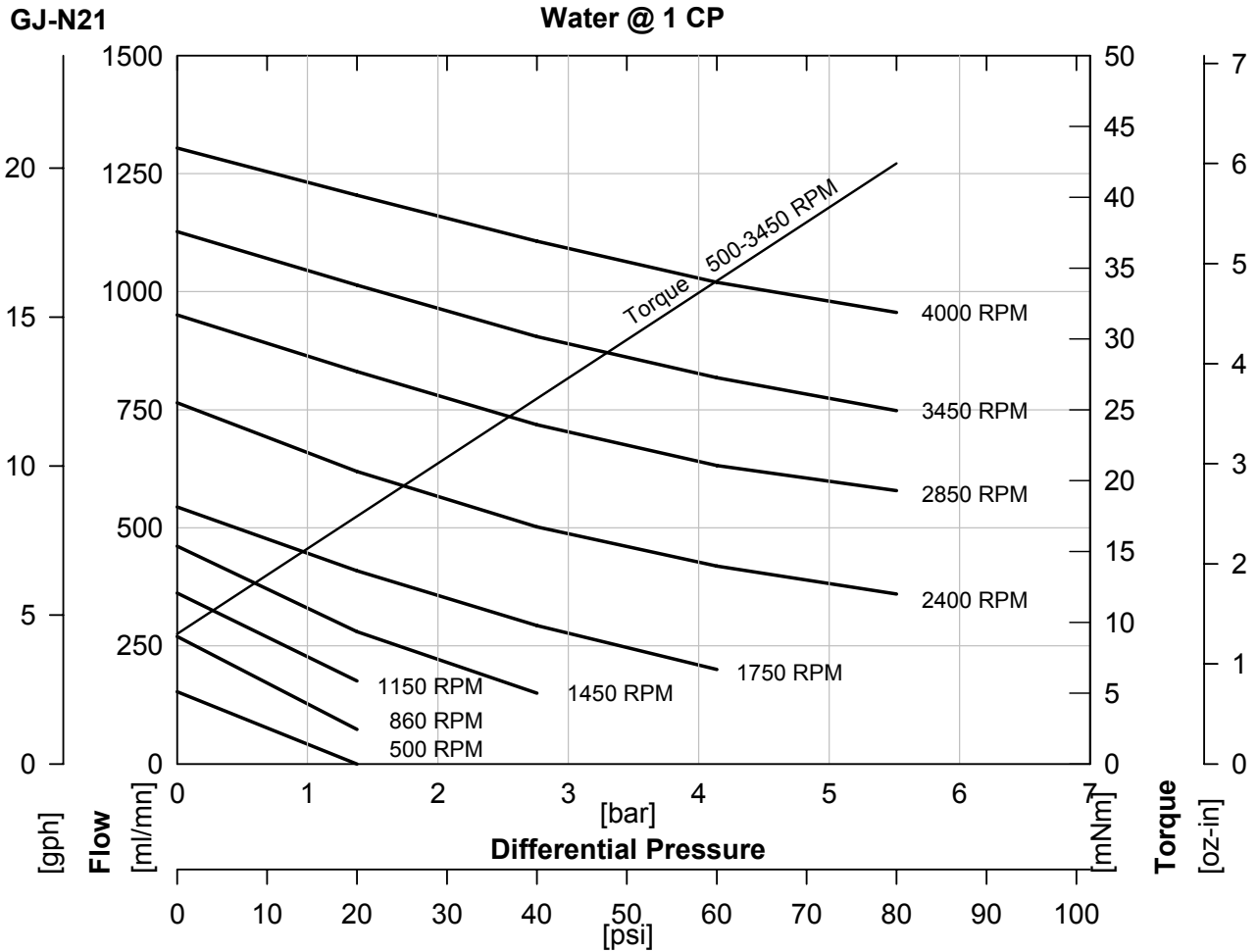

ACTUAL PERFORMANCE MAY VARY - Specifications are subject to change without notice. When multiple specs are noted, the most conservative value applies.

USA: Micropump, Inc., A Unit of IDEX Corporation • Phone 360.253.2008 • Fax 360.253.2401
 UK: Micropump, Ltd., A Subsidiary of Micropump, Inc. • Phone +44 (1480) 356900 • Fax +44 (1480) 356920
 info@micropump.com www.micropump.com

Order Code				Pump Construction			
Base Code		Gear Set		Drive Mount		Options	
G	J	-	N21			A	
1	2	3	4	5	6	7	8
Model				Wetted Materials			
				O/C: Pump S/K: Service Kit			
				Magnetic Drive Gear Pump Cavity Style Two Helical, Shafted Gears/DP24 Sleeve Bushings/Gasket Seals (2) PTFE Bevel or O-Ring Seal (1) PPS Driven Magnet			



Dimensions

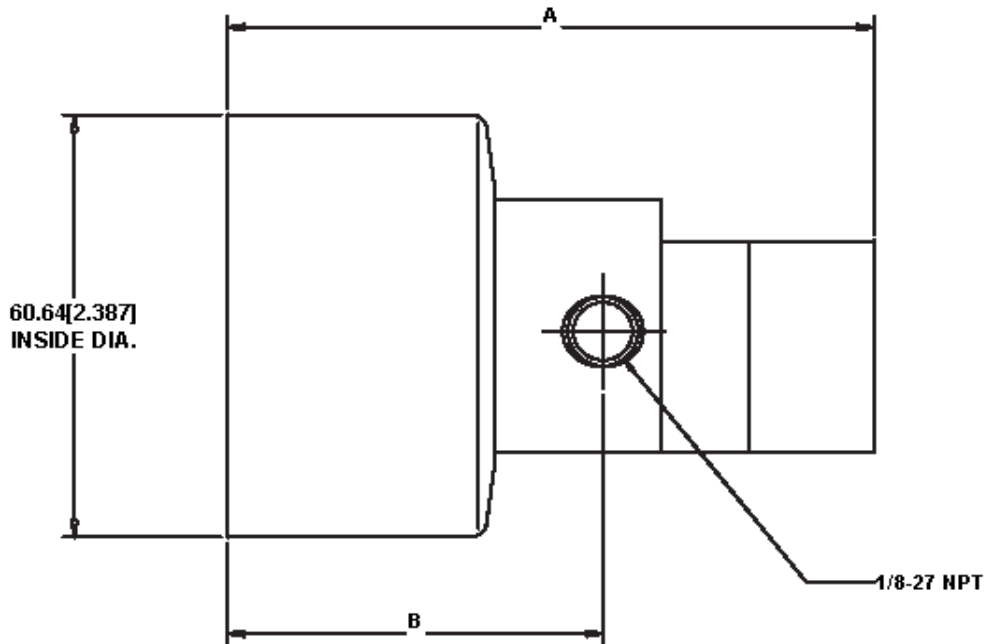

GEAR SET	A (MAX) mm [in]	B mm [in]
N21	86.0 [3.39]	54.6 [2.15]
N23	90.4 [3.56]	54.6 [2.15]
N25	94.4 [3.72]	54.6 [2.15]
N27	99.2 [3.91]	54.6 [2.15]

NOTES:
1. ALL DIMENSIONS ARE NOMINAL.

ACTUAL PERFORMANCE MAY VARY - Specifications are subject to change without notice. When multiple specs are noted, the most conservative value applies.

USA: Micropump, Inc., A Unit of IDEX Corporation • Phone 360.253.2008 • Fax 360.253.2401
 UK: Micropump, Ltd., A Subsidiary of Micropump, Inc. • Phone +44 (1480) 356900 • Fax +44 (1480) 356920
 info@micropump.com www.micropump.com

Order Code				Pump Construction			
Base Code		Gear Set	Drive Mount	Magnetic Drive Gear Pump			
G	J	-	N21	Cavity Style			
1	2	3	4	5	6	7	8
Model			Wetted Materials				Options
							O/C: Pump
							S/K: Service Kit
				Two Helical, Shafted Gears/DP24			
				Sleeve Bushings/Gasket Seals (2)			
				PTFE Bevel or O-Ring Seal (1)			
				PPS Driven Magnet			



Dimensions

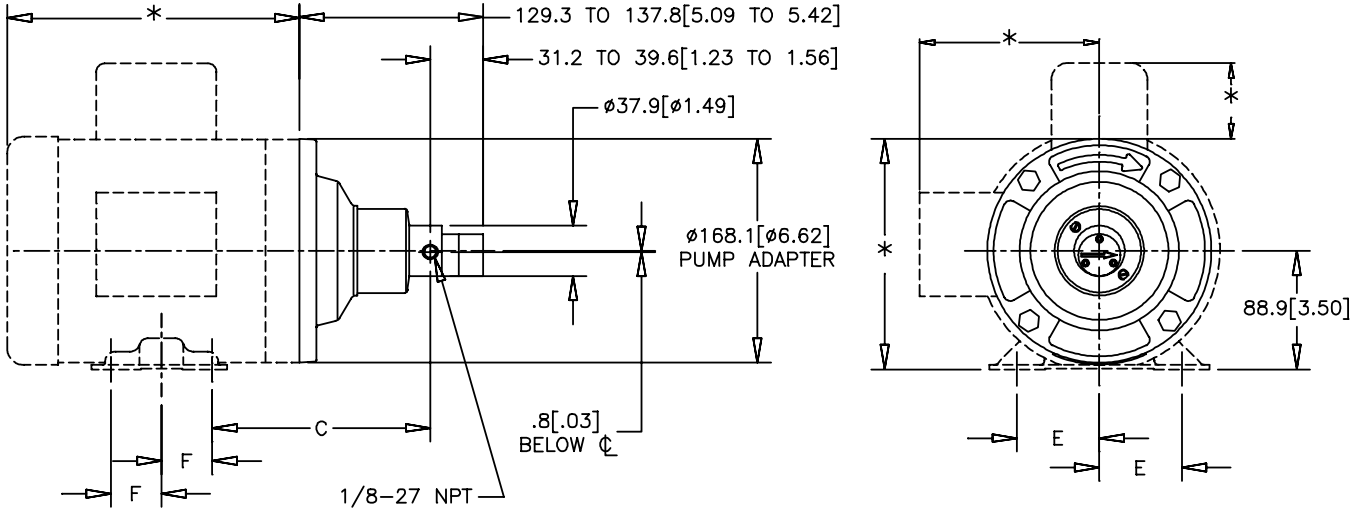

MOUNT	C mm [in]	E mm [in]	F mm [in]
NEMA ^E 56C	163.4 [6.43]	61.9 [2.44]	38.1 [1.50]
NEMA ^K 143TC	158.5 [6.24]	69.9 [2.75]	50.8 [2.00]
NEMA ^K 145TC	158.5 [6.24]	69.9 [2.75]	63.5 [2.50]

NOTES:

- *THESE DIMENSIONS WILL VARY BASED ON MOTOR SELECTION.
- ALL DIMENSIONS ARE NOMINAL.

ACTUAL PERFORMANCE MAY VARY - Specifications are subject to change without notice. When multiple specs are noted, the most conservative value applies.

USA: Micropump, Inc., A Unit of IDEX Corporation • Phone 360.253.2008 • Fax 360.253.2401
 UK: Micropump, Ltd., A Subsidiary of Micropump, Inc. • Phone +44 (1480) 356900 • Fax +44 (1480) 356920
 info@micropump.com www.micropump.com

Order Code				Pump Construction			
Base Code		Gear Set		Drive Mount		Options	
G	J	-	N21			6	
1	2	3	4	5	6	7	8
Model				Wetted Materials			
				O/C: Pump S/K: Service Kit			
				Magnetic Drive Gear Pump Cavity Style Two Helical, Shafted Gears/DP24 Sleeve Bushings/Gasket Seals (2) PTFE Bevel or O-Ring Seal (1) PPS Driven Magnet			



Dimensions

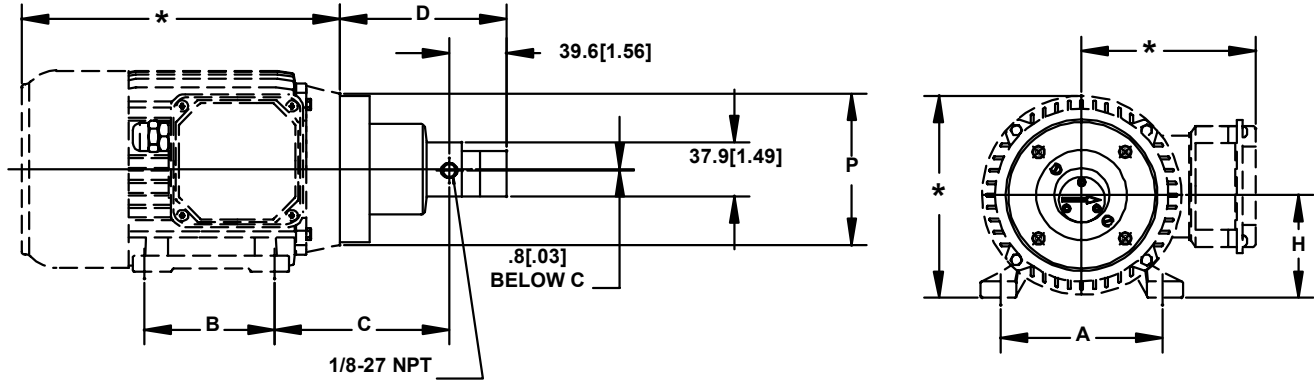

MOUNT	A mm [in]	B mm [in]	C mm [in]	D mm [in]	H mm [in]	P mm [in]
2 IEC56B14B3	90 [3.54]	71 [2.80]	99.2 [3.90]	94.5 [3.72] TO 102.8 [4.05]	56 [2.20]	80 [3.15]
4 IEC63B14B3	100 [3.94]	80 [3.15]	108.8 [4.28]	100.1 [3.94] TO 108.5 [4.27]	63 [2.48]	90 [3.54]
6 IEC71B14B3	112 [4.41]	90 [3.54]	120.8 [4.76]	107.1 [4.22] TO 115.5 [4.55]	71 [2.80]	105 [4.13]

NOTES:

- *THESE DIMENSIONS WIL VARY BASED ON MOTOR SELECTION.
- ALL DIMENSIONSARE NOMINAL.

ACTUAL PERFORMANCE MAY VARY - Specifications are subject to change without notice. When multiple specs are noted, the most conservative value applies.

USA: Micropump, Inc., A Unit of IDEX Corporation • Phone 360.253.2008 • Fax 360.253.2401
 UK: Micropump, Ltd., A Subsidiary of Micropump, Inc. • Phone +44 (1480) 356900 • Fax +44 (1480) 356920
 info@micropump.com www.micropump.com

Order Code				Pump Construction			
Base Code		Gear - Set		Drive Mount -		Options	
G	J	-	N23				
1	2	3	4	5	6	7	8
Model				Wetted Materials			
				O/C: Pump S/K: Service Kit			
				Magnetic Drive Gear Pump Cavity Style Two Helical, Shafted Gears/DP24 Sleeve Bushings/Gasket Seals (2) PTFE Bevel or O-Ring Seal (1) PPS Driven Magnet			



Performance

GJ-N23

Water @ 1 CP

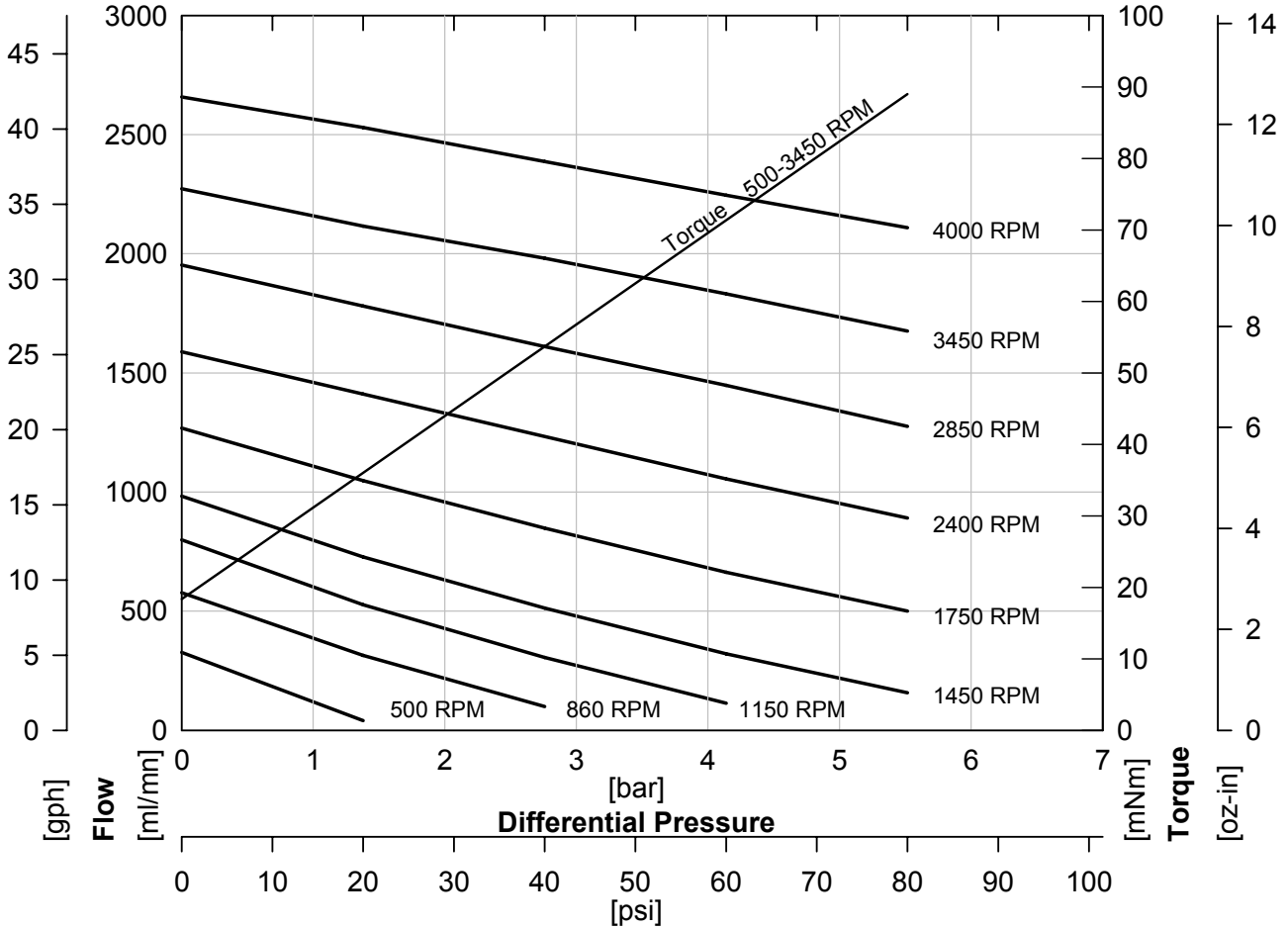

ACTUAL PERFORMANCE MAY VARY - Specifications are subject to change without notice. When multiple specs are noted, the most conservative value applies.

USA: Micropump, Inc., A Unit of IDEX Corporation • Phone 360.253.2008 • Fax 360.253.2401
 UK: Micropump, Ltd., A Subsidiary of Micropump, Inc. • Phone +44 (1480) 356900 • Fax +44 (1480) 356920
 info@micropump.com www.micropump.com

Order Code				Pump Construction			
Base Code		Gear Set		Drive Mount		Options	
G	J	-	N23			A	
1	2	3	4	5	6	7	8
Model				Wetted Materials			
				O/C: Pump S/K: Service Kit			
				Magnetic Drive Gear Pump Cavity Style Two Helical, Shafted Gears/DP24 Sleeve Bushings/Gasket Seals (2) PTFE Bevel or O-Ring Seal (1) PPS Driven Magnet			



Dimensions

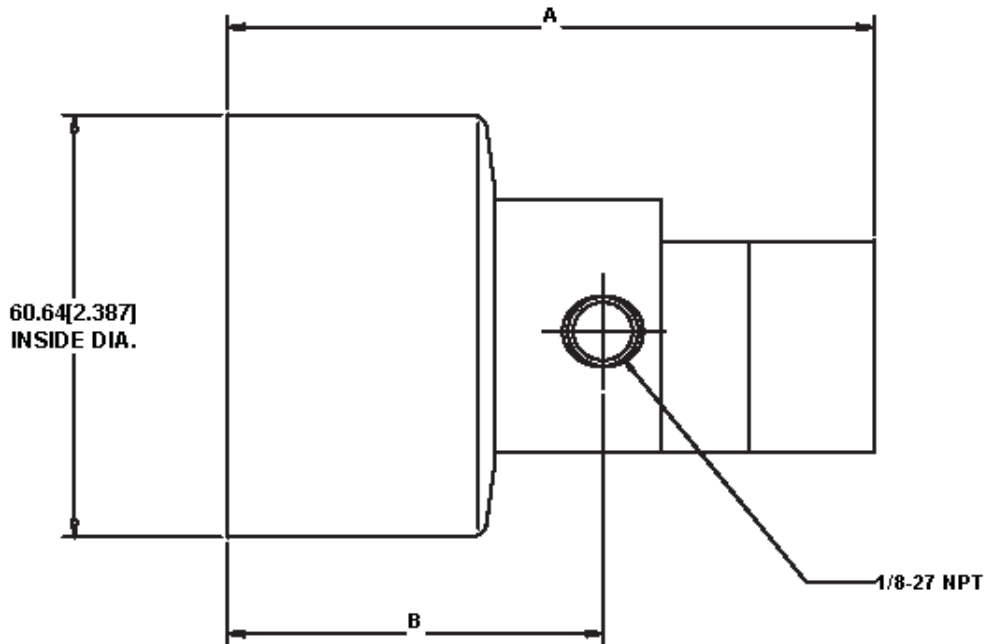

GEAR SET	A (MAX) mm [in]	B mm [in]
N21	86.0 [3.39]	54.6 [2.15]
N23	90.4 [3.56]	54.6 [2.15]
N25	94.4 [3.72]	54.6 [2.15]
N27	99.2 [3.91]	54.6 [2.15]

NOTES:
1. ALL DIMENSIONS ARE NOMINAL.

ACTUAL PERFORMANCE MAY VARY - Specifications are subject to change without notice. When multiple specs are noted, the most conservative value applies.

USA: Micropump, Inc., A Unit of IDEX Corporation • Phone 360.253.2008 • Fax 360.253.2401
UK: Micropump, Ltd., A Subsidiary of Micropump, Inc. • Phone +44 (1480) 356900 • Fax +44 (1480) 356920
info@micropump.com www.micropump.com

Order Code				Pump Construction			
Base Code		Gear Set		Drive Mount		Options	
G	J	-	N23	5	6	7	E
Model			Wetted Materials			O/C: Pump S/K: Service Kit	
Magnetic Drive Gear Pump Cavity Style Two Helical, Shafted Gears/DP24 Sleeve Bushings/Gasket Seals (2) PTFE Bevel or O-Ring Seal (1) PPS Driven Magnet							



Dimensions

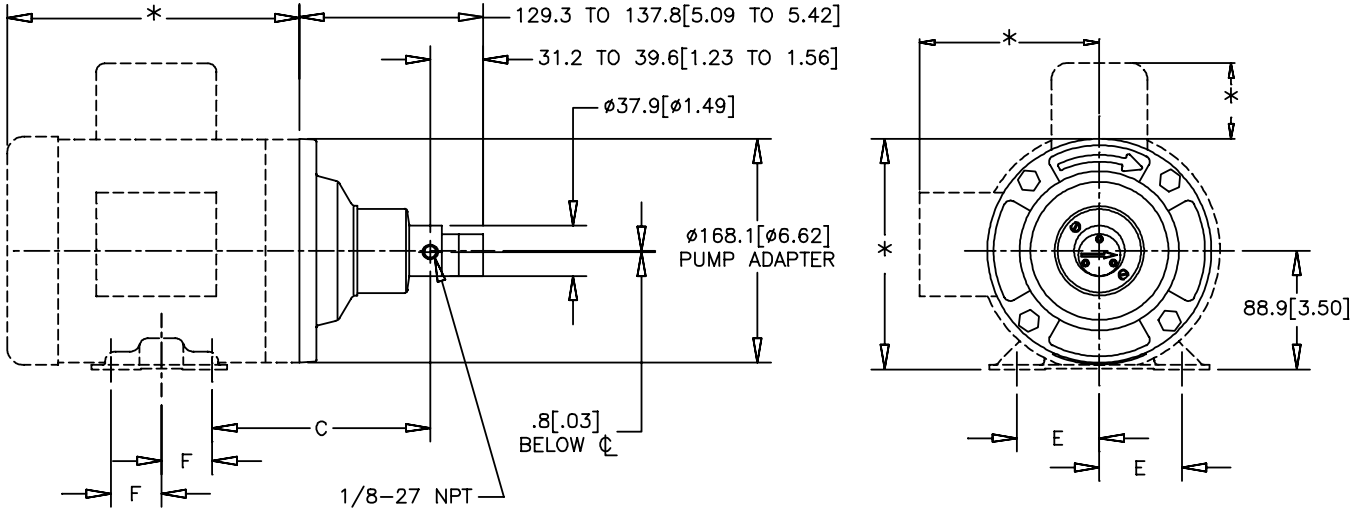

MOUNT	C mm [in]	E mm [in]	F mm [in]
NEMA ^E 56C	163.4 [6.43]	61.9 [2.44]	38.1 [1.50]
NEMA ^K 143TC	158.5 [6.24]	69.9 [2.75]	50.8 [2.00]
NEMA ^K 145TC	158.5 [6.24]	69.9 [2.75]	63.5 [2.50]

NOTES:

- *THESE DIMENSIONS WILL VARY BASED ON MOTOR SELECTION.
- ALL DIMENSIONS ARE NOMINAL.

ACTUAL PERFORMANCE MAY VARY - Specifications are subject to change without notice. When multiple specs are noted, the most conservative value applies.

USA: Micropump, Inc., A Unit of IDEX Corporation • Phone 360.253.2008 • Fax 360.253.2401
 UK: Micropump, Ltd., A Subsidiary of Micropump, Inc. • Phone +44 (1480) 356900 • Fax +44 (1480) 356920
 info@micropump.com www.micropump.com

Order Code				Pump Construction			
Base Code		Gear Set		Drive Mount		Options	
G	J	-	N23			6	
1 2 Model		3 4 5 6 7 8 Wetted Materials				O/C: Pump S/K: Service Kit	
				Magnetic Drive Gear Pump Cavity Style Two Helical, Shafted Gears/DP24 Sleeve Bushings/Gasket Seals (2) PTFE Bevel or O-Ring Seal (1) PPS Driven Magnet			



Dimensions

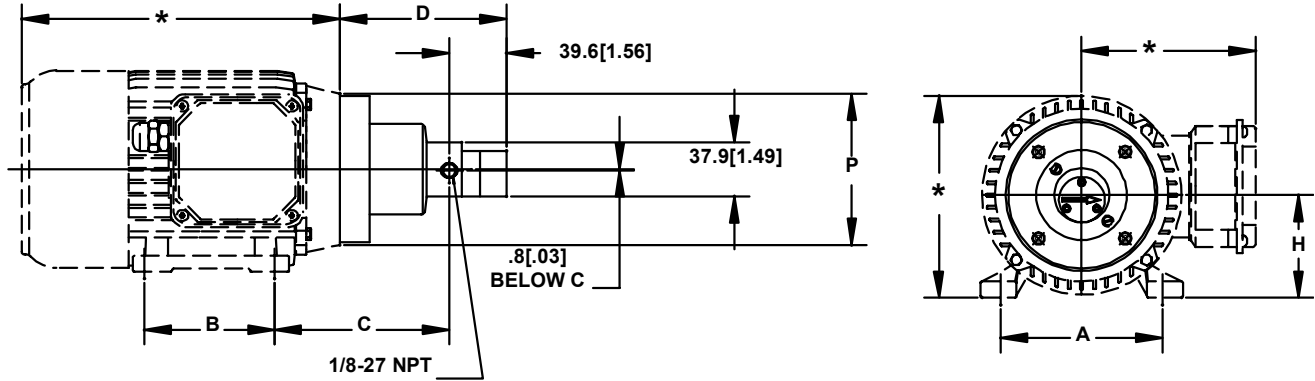

MOUNT	A mm [in]	B mm [in]	C mm [in]	D mm [in]	H mm [in]	P mm [in]
2 IEC56B14B3	90 [3.54]	71 [2.80]	99.2 [3.90]	94.5 [3.72] TO 102.8 [4.05]	56 [2.20]	80 [3.15]
4 IEC63B14B3	100 [3.94]	80 [3.15]	108.8 [4.28]	100.1 [3.94] TO 108.5 [4.27]	63 [2.48]	90 [3.54]
6 IEC71B14B3	112 [4.41]	90 [3.54]	120.8 [4.76]	107.1 [4.22] TO 115.5 [4.55]	71 [2.80]	105 [4.13]

NOTES:

- *THESE DIMENSIONS WIL VARY BASED ON MOTOR SELECTION.
- ALL DIMENSIONSARE NOMINAL.

ACTUAL PERFORMANCE MAY VARY - Specifications are subject to change without notice. When multiple specs are noted, the most conservative value applies.

USA: Micropump, Inc., A Unit of IDEX Corporation • Phone 360.253.2008 • Fax 360.253.2401
 UK: Micropump, Ltd., A Subsidiary of Micropump, Inc. • Phone +44 (1480) 356900 • Fax +44 (1480) 356920
 info@micropump.com www.micropump.com

Order Code				Pump Construction			
Base Code		Gear - Set		Drive Mount		Options	
G	J	-	N25				
1	2	3	4	5	6	7	8
Model				Wetted Materials			
				O/C: Pump S/K: Service Kit			
				Magnetic Drive Gear Pump Cavity Style Two Helical, Shafted Gears/DP24 Sleeve Bushings/Gasket Seals (2) PTFE Bevel or O-Ring Seal (1) PPS Driven Magnet			



Performance

GJ-N25

Water @ 1 CP

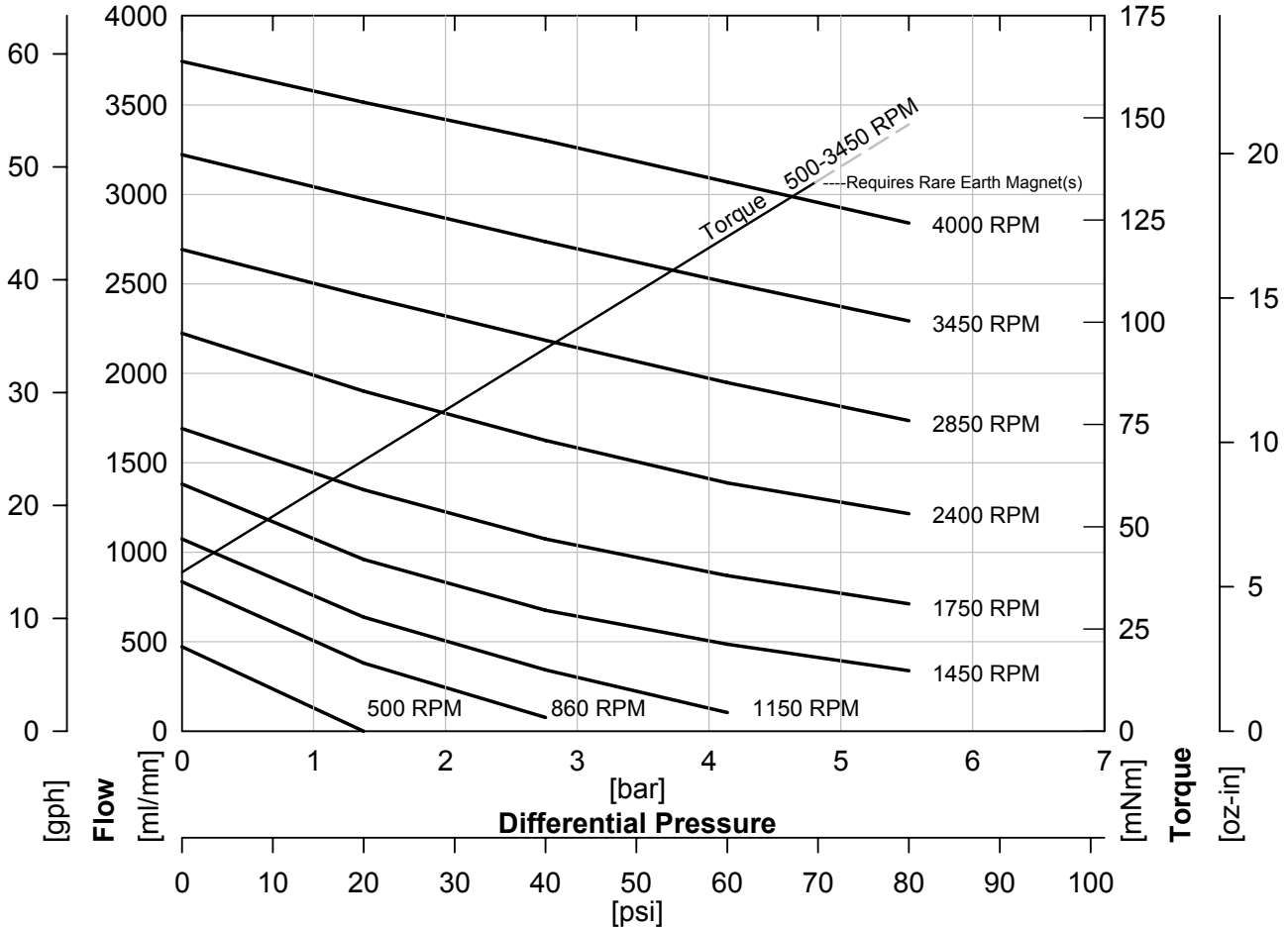

ACTUAL PERFORMANCE MAY VARY - Specifications are subject to change without notice. When multiple specs are noted, the most conservative value applies.

USA: Micropump, Inc., A Unit of IDEX Corporation • Phone 360.253.2008 • Fax 360.253.2401
 UK: Micropump, Ltd., A Subsidiary of Micropump, Inc. • Phone +44 (1480) 356900 • Fax +44 (1480) 356920
 info@micropump.com www.micropump.com

Order Code				Pump Construction			
Base Code		Gear - Set		Drive Mount		Options	
G	J	-	N25	5	6	7	8
Model		Wetted Materials		O/C: Pump S/K: Service Kit			
<p>Pump Construction Magnetic Drive Gear Pump Cavity Style Two Helical, Shafted Gears/DP24 Sleeve Bushings/Gasket Seals (2) PTFE Bevel or O-Ring Seal (1) PPS Driven Magnet</p>							



Performance-High Viscosity

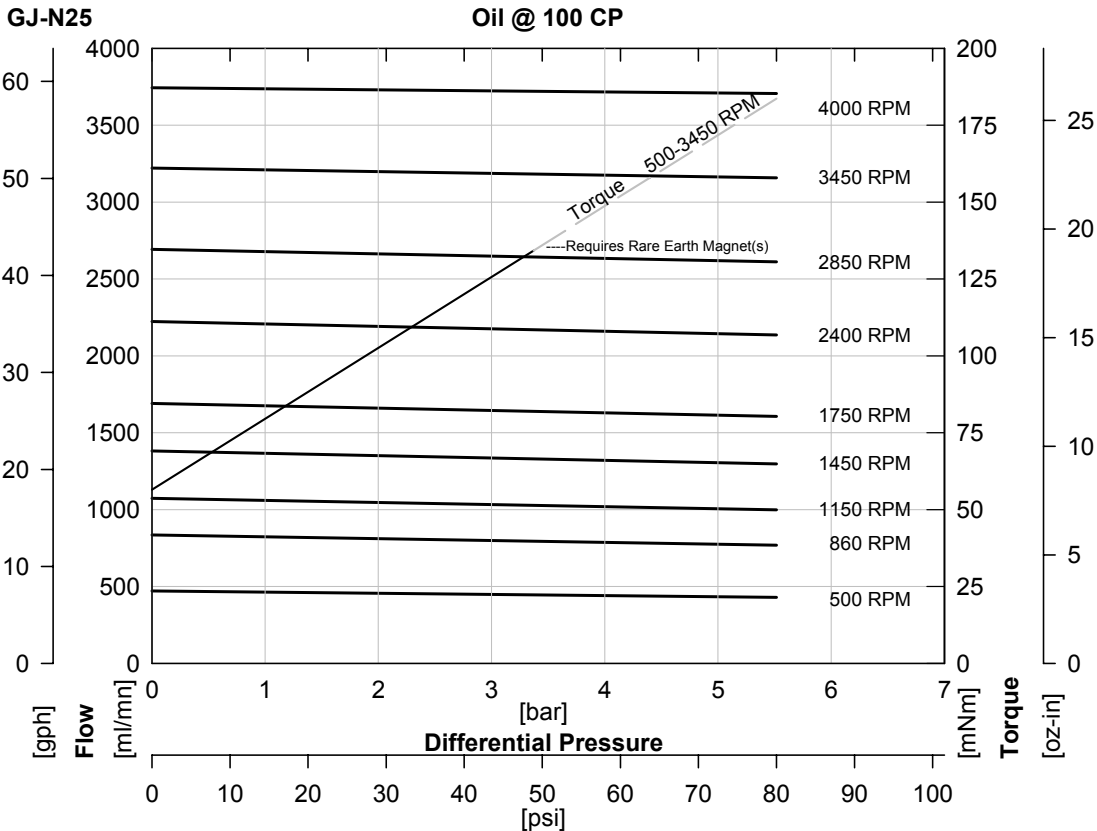

$$\text{Watts} = \frac{\text{Torque [mNm]} \times \text{Speed [RPM]}}{9555}$$

$$\text{HP} = \frac{\text{Torque [oz-in]} \times \text{Speed [RPM]}}{1.008 \times 10^6}$$

To calculate torque, multiply correction factor by torque from viscosity curve above.

Torque Correction Factors: For Higher Viscosity Liquids				
Viscosity [cp]		1	100	1500
Max Speed [RPM]		10000	3450	300
[Bar]	[psi]			
0.3	5	0.7	1	1.3
1.4	20	0.7	1	1.2
2.8	40	0.8	1	1.1
4.1	60	0.8	1	1.1
5.5	80	0.8	1	1.1

Magnet Decouple Torque			
Driven Magnet	Driving Hub	Torque [mNm]	Torque [oz.in]
Ferrite	Ferrite*	113	16
Ferrite	Ferrite**	134	19
Ferrite	SmCo	254	36
SmCo	SmCo	636	90
Ferrite	NdFeB	304	43
SmCo	NdFeB	932	132

ACTUAL PERFORMANCE MAY VARY - Specifications are subject to change without notice. When multiple specs are noted, the most conservative value applies.

USA: Micropump, Inc., A Unit of IDEX Corporation • Phone 360.253.2008 • Fax 360.253.2401
 UK: Micropump, Ltd., A Subsidiary of Micropump, Inc. • Phone +44 (1480) 356900 • Fax +44 (1480) 356920
 info@micropump.com www.micropump.com

Order Code				Pump Construction			
Base Code		Gear Set		Drive Mount		Options	
G	J	-	N25			A	
1	2	3	4	5	6	7	8
Model				Wetted Materials			
				O/C: Pump S/K: Service Kit			
				Magnetic Drive Gear Pump Cavity Style Two Helical, Shafted Gears/DP24 Sleeve Bushings/Gasket Seals (2) PTFE Bevel or O-Ring Seal (1) PPS Driven Magnet			



Dimensions

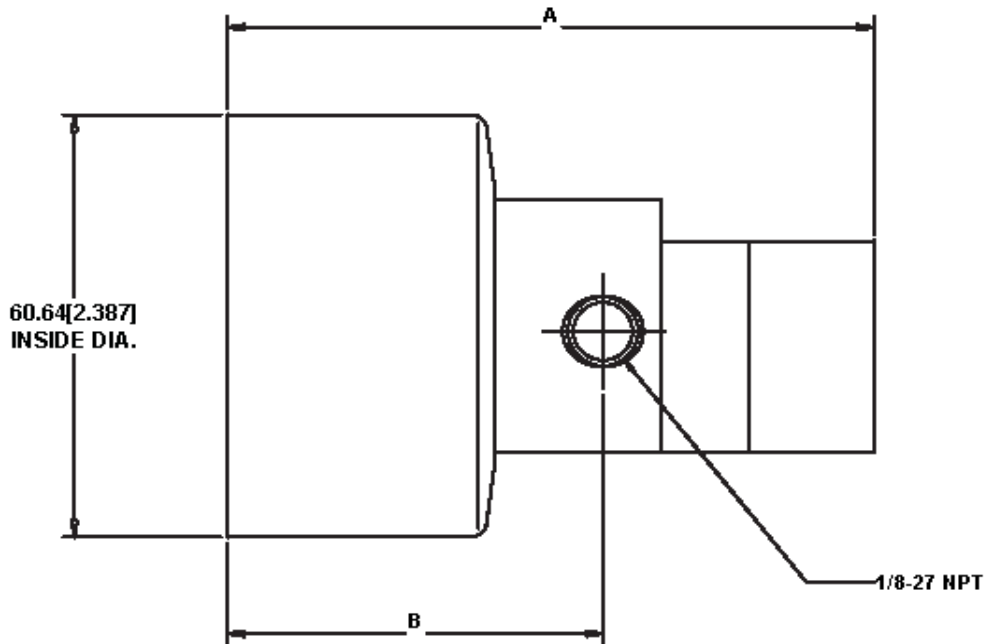

GEAR SET	A (MAX) mm [in]	B mm [in]
N21	86.0 [3.39]	54.6 [2.15]
N23	90.4 [3.56]	54.6 [2.15]
N25	94.4 [3.72]	54.6 [2.15]
N27	99.2 [3.91]	54.6 [2.15]

NOTES:
1. ALL DIMENSIONS ARE NOMINAL.

ACTUAL PERFORMANCE MAY VARY - Specifications are subject to change without notice. When multiple specs are noted, the most conservative value applies.

USA: Micropump, Inc., A Unit of IDEX Corporation • Phone 360.253.2008 • Fax 360.253.2401
 UK: Micropump, Ltd., A Subsidiary of Micropump, Inc. • Phone +44 (1480) 356900 • Fax +44 (1480) 356920
 info@micropump.com www.micropump.com

Order Code				Pump Construction			
Base Code		Gear Set	Drive Mount	Magnetic Drive Gear Pump			
G	J	-	N25	Cavity Style			
1	2	3	4	5	6	7	8
Model			Wetted Materials				Options
							O/C: Pump S/K: Service Kit
				Two Helical, Shafted Gears/DP24			
				Sleeve Bushings/Gasket Seals (2)			
				PTFE Bevel or O-Ring Seal (1)			
				PPS Driven Magnet			



Dimensions

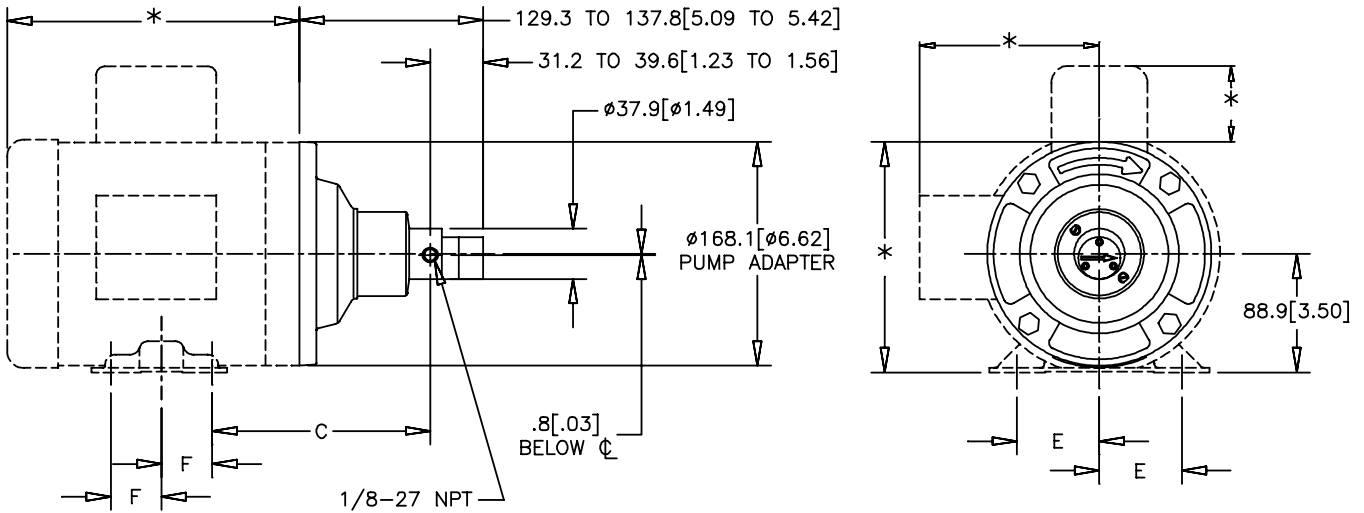

MOUNT	C mm [in]	E mm [in]	F mm [in]
NEMA ^E 56C	163.4 [6.43]	61.9 [2.44]	38.1 [1.50]
NEMA ^K 143TC	158.5 [6.24]	69.9 [2.75]	50.8 [2.00]
NEMA ^K 145TC	158.5 [6.24]	69.9 [2.75]	63.5 [2.50]

NOTES:

- *THESE DIMENSIONS WILL VARY BASED ON MOTOR SELECTION.
- ALL DIMENSIONS ARE NOMINAL.

ACTUAL PERFORMANCE MAY VARY - Specifications are subject to change without notice. When multiple specs are noted, the most conservative value applies.

USA: Micropump, Inc., A Unit of IDEX Corporation • Phone 360.253.2008 • Fax 360.253.2401
 UK: Micropump, Ltd., A Subsidiary of Micropump, Inc. • Phone +44 (1480) 356900 • Fax +44 (1480) 356920
 info@micropump.com www.micropump.com

Order Code				Pump Construction			
Base Code		Gear Set		Drive Mount		Options	
G	J	-	N25			6	
1	2	3	4	5	6	7	8
Model			Wetted Materials			O/C: Pump S/K: Service Kit	
Magnetic Drive Gear Pump Cavity Style Two Helical, Shafted Gears/DP24 Sleeve Bushings/Gasket Seals (2) PTFE Bevel or O-Ring Seal (1) PPS Driven Magnet							



Dimensions

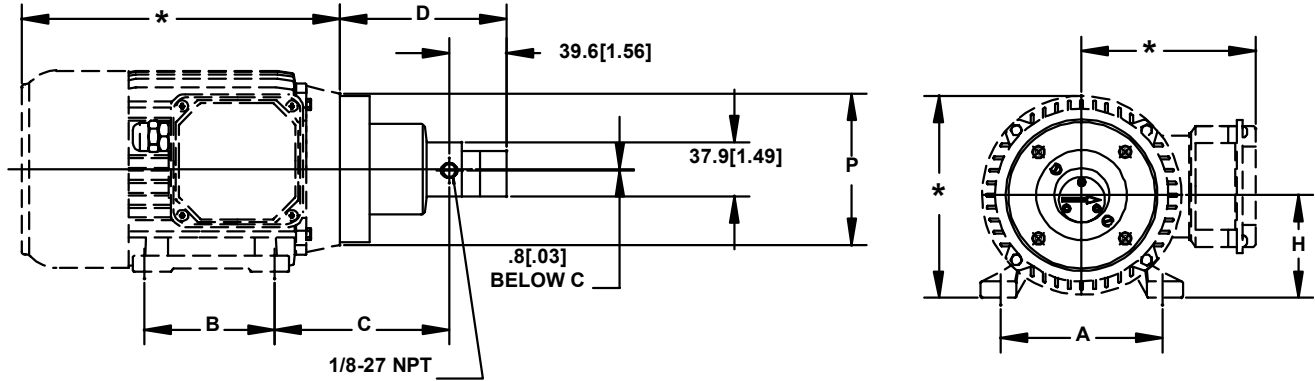

MOUNT	A mm [in]	B mm [in]	C mm [in]	D mm [in]	H mm [in]	P mm [in]
2 IEC56B14B3	90 [3.54]	71 [2.80]	99.2 [3.90]	94.5 [3.72] TO 102.8 [4.05]	56 [2.20]	80 [3.15]
4 IEC63B14B3	100 [3.94]	80 [3.15]	108.8 [4.28]	100.1 [3.94] TO 108.5 [4.27]	63 [2.48]	90 [3.54]
6 IEC71B14B3	112 [4.41]	90 [3.54]	120.8 [4.76]	107.1 [4.22] TO 115.5 [4.55]	71 [2.80]	105 [4.13]

NOTES:

- *THESE DIMENSIONS WIL VARY BASED ON MOTOR SELECTION.
- ALL DIMENSIONS ARE NOMINAL.

ACTUAL PERFORMANCE MAY VARY - Specifications are subject to change without notice. When multiple specs are noted, the most conservative value applies.

USA: Micropump, Inc., A Unit of IDEX Corporation • Phone 360.253.2008 • Fax 360.253.2401
 UK: Micropump, Ltd., A Subsidiary of Micropump, Inc. • Phone +44 (1480) 356900 • Fax +44 (1480) 356920
 info@micropump.com www.micropump.com

Order Code				Pump Construction			
Base Code		Gear - Set		Drive Mount -		Options	
G	J	-	N27				
1	2	3	4	5	6	7	8
Model				Wetted Materials			
				O/C: Pump S/K: Service Kit			
				Magnetic Drive Gear Pump Cavity Style Two Helical, Shafted Gears/DP24 Sleeve Bushings/Gasket Seals (2) PTFE Bevel or O-Ring Seal (1) PPS Driven Magnet			



Performance

GJ-N27

Water @ 1 CP

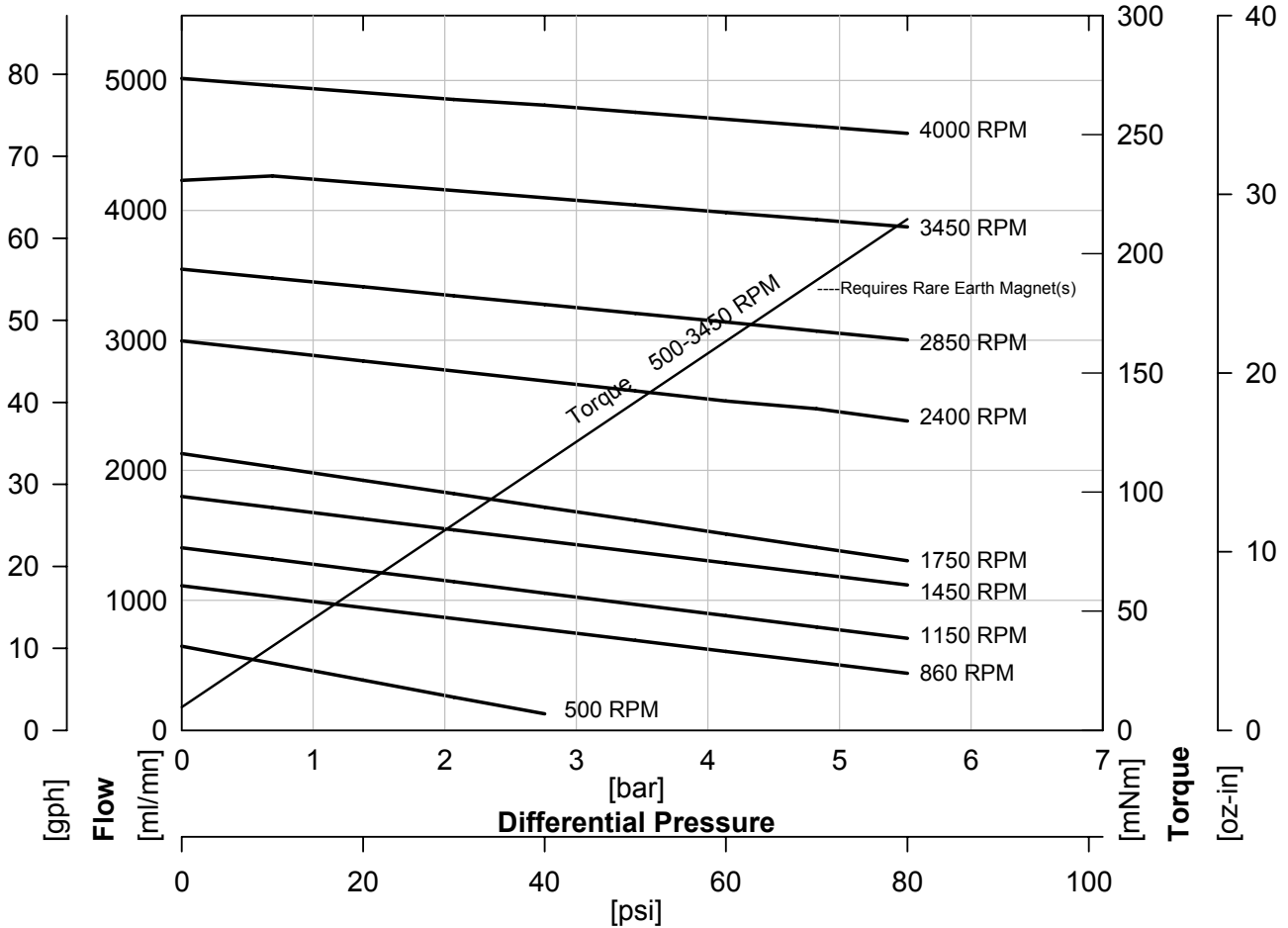

ACTUAL PERFORMANCE MAY VARY - Specifications are subject to change without notice. When multiple specs are noted, the most conservative value applies.

USA: Micropump, Inc., A Unit of IDEX Corporation • Phone 360.253.2008 • Fax 360.253.2401
 UK: Micropump, Ltd., A Subsidiary of Micropump, Inc. • Phone +44 (1480) 356900 • Fax +44 (1480) 356920
 info@micropump.com www.micropump.com

Order Code				Pump Construction			
Base Code		Gear - Set	Drive Mount		Options		
G	J	-	N27				
1	2	3	4	5	6	7	8
Model				Wetted Materials			
				O/C: Pump S/K: Service Kit			



Performance-High Viscosity

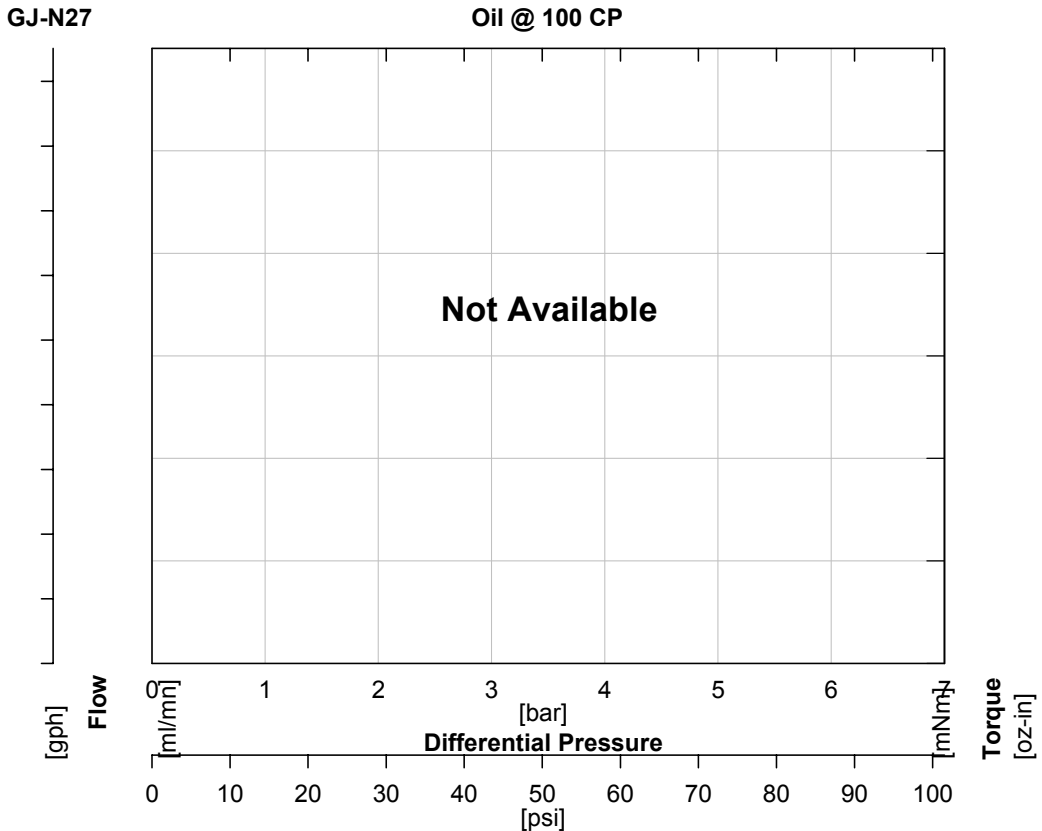

$$\text{Watts} = \frac{\text{Torque [mNm]} \times \text{Speed [RPM]}}{9555}$$

$$\text{HP} = \frac{\text{Torque [oz-in]} \times \text{Speed [RPM]}}{1.008 \times 10^6}$$

To calculate torque, multiply correction factor by torque from viscosity curve above.

Torque Correction Factors: For Higher Viscosity Liquids				
Viscosity [cp]		1	100	1500
Max Speed [RPM]		10000	3450	200
[Bar]	[psi]			
0.3	5	0.4	1	1.1
1.4	20	0.6	1	1.1
2.8	40	0.8	1	1.1
4.1	60	0.8	1	1.1
5.5	80	0.9	1	1.1
6.2	90	0.9	1	1.1

Magnet Decouple Torque			
Driven Magnet	Driving Hub	Torque [mNm]	Torque [oz.in]
Ferrite	Ferrite	134	19
Ferrite	NdFeB	304	43
NdFeB	Ferrite	290	41
NdFeB	NdFeB	636	90

ACTUAL PERFORMANCE MAY VARY - Specifications are subject to change without notice. When multiple specs are noted, the most conservative value applies.

USA: Micropump, Inc., A Unit of IDEX Corporation • Phone 360.253.2008 • Fax 360.253.2401
UK: Micropump, Ltd., A Subsidiary of Micropump, Inc. • Phone +44 (1480) 356900 • Fax +44 (1480) 356920
info@micropump.com www.micropump.com

Order Code				Pump Construction			
Base Code		Gear - Set		Drive Mount		Options	
G	J	-	N27				
1	2	3	4	5	6	7	8
Model				Wetted Materials			
				O/C: Pump S/K: Service Kit			
				Magnetic Drive Gear Pump Cavity Style Two Helical, Shafted Gears/DP24 Sleeve Bushings/Gasket Seals (2) PTFE Bevel or O-Ring Seal (1) PPS Driven Magnet			



Specifications

	SI	US
Displacement	1.23 ml/rev	0.32 gal/1000*rev
Max Flow (4 Pole Speed)	1630 ml/mn 1450 RPM (50Hz)	32 gal/hr 1750 RPM (60Hz)
Max Flow (2 Pole Speed)	3250 ml/mn 2850 RPM (50Hz)	1.0 gal/mn 3450 RPM (60Hz)
Max Differential Pressure	8.7 Bar	125 psi
Max System Pressure (MAWP)	21 Bar	300 psi
NIPR (Absolute)	180 mBar	2.5 psia
Wet Lift (Typical)	51 cm.H2O (1450 RPM)	24 in.H2O (1750 RPM)
Temp Range	See Gear Material	See Gear Material
Viscosity Range	0.2 to 1500 cp	0.2 to 1500 cp
Max Speed	10,000 RPM	10,000 RPM
Rotation (Facing Motor Shaft)	CW	CW
Weight (Pumphead)	0.45 kg	1.0 lbs
Dimensions (LxWxH)	See Drawing	See Drawing
Ports	1/8-27 (F) NPT Side Ports	1/8-27 (F) NPT Side Ports
Driven Magnet (Standard)	Neodymium (NdFeB)	Neodymium (NdFeB)
Optional Internal Bypass	Yes	Yes

Notes

4 See Performance-High Viscosity for viscosity limits.

ACTUAL PERFORMANCE MAY VARY - Specifications are subject to change without notice. When multiple specs are noted, the most conservative value applies.

USA: Micropump, Inc., A Unit of IDEX Corporation • Phone 360.253.2008 • Fax 360.253.2401
 UK: Micropump, Ltd., A Subsidiary of Micropump, Inc. • Phone +44 (1480) 356900 • Fax +44 (1480) 356920
 info@micropump.com www.micropump.com

Order Code				Pump Construction			
Base Code		Gear Set		Drive Mount		Options	
G	J	-	N27				
1	2	3	4	5	6	7	8
Model				Wetted Materials			
				O/C: Pump S/K: Service Kit			
				Magnetic Drive Gear Pump Cavity Style Two Helical, Shafted Gears/DP24 Sleeve Bushings/Gasket Seals (2) PTFE Bevel or O-Ring Seal (1) PPS Driven Magnet			



Dimensions

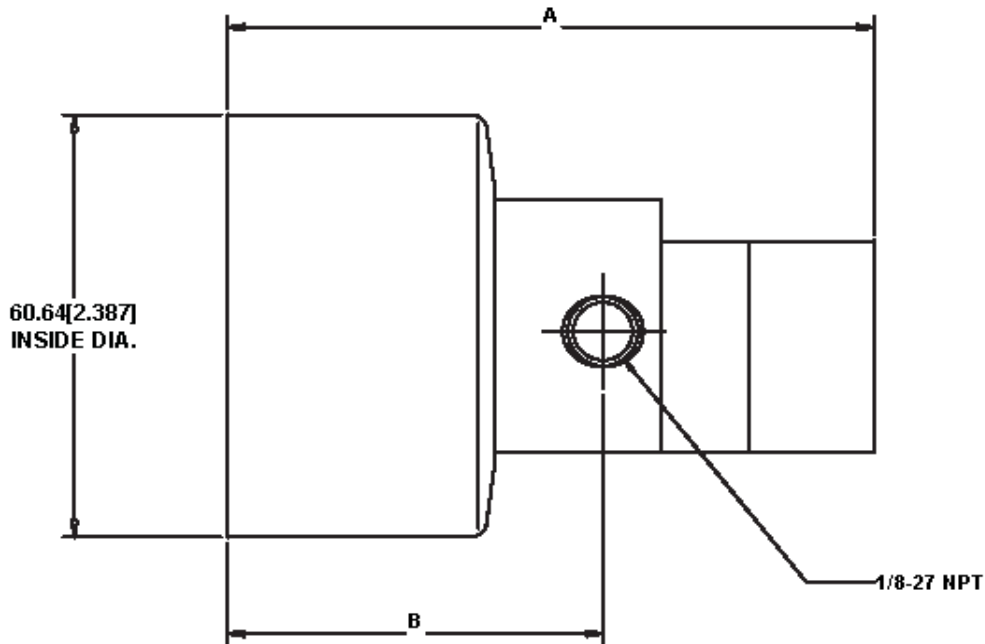

GEAR SET	A (MAX) mm [in]	B mm [in]
N21	86.0 [3.39]	54.6 [2.15]
N23	90.4 [3.56]	54.6 [2.15]
N25	94.4 [3.72]	54.6 [2.15]
N27	99.2 [3.91]	54.6 [2.15]

NOTES:
1. ALL DIMENSIONS ARE NOMINAL.

ACTUAL PERFORMANCE MAY VARY - Specifications are subject to change without notice. When multiple specs are noted, the most conservative value applies.

USA: Micropump, Inc., A Unit of IDEX Corporation • Phone 360.253.2008 • Fax 360.253.2401
UK: Micropump, Ltd., A Subsidiary of Micropump, Inc. • Phone +44 (1480) 356900 • Fax +44 (1480) 356920
info@micropump.com www.micropump.com

Order Code				Pump Construction			
Base Code		Gear Set	Drive Mount	Magnetic Drive Gear Pump			
G	J	-	N27	Cavity Style			
1	2	3	4	5	6	7	8
Model			Wetted Materials				Options
							O/C: Pump S/K: Service Kit
				Two Helical, Shafted Gears/DP24			
				Sleeve Bushings/Gasket Seals (2)			
				PTFE Bevel or O-Ring Seal (1)			
				PPS Driven Magnet			



Dimensions

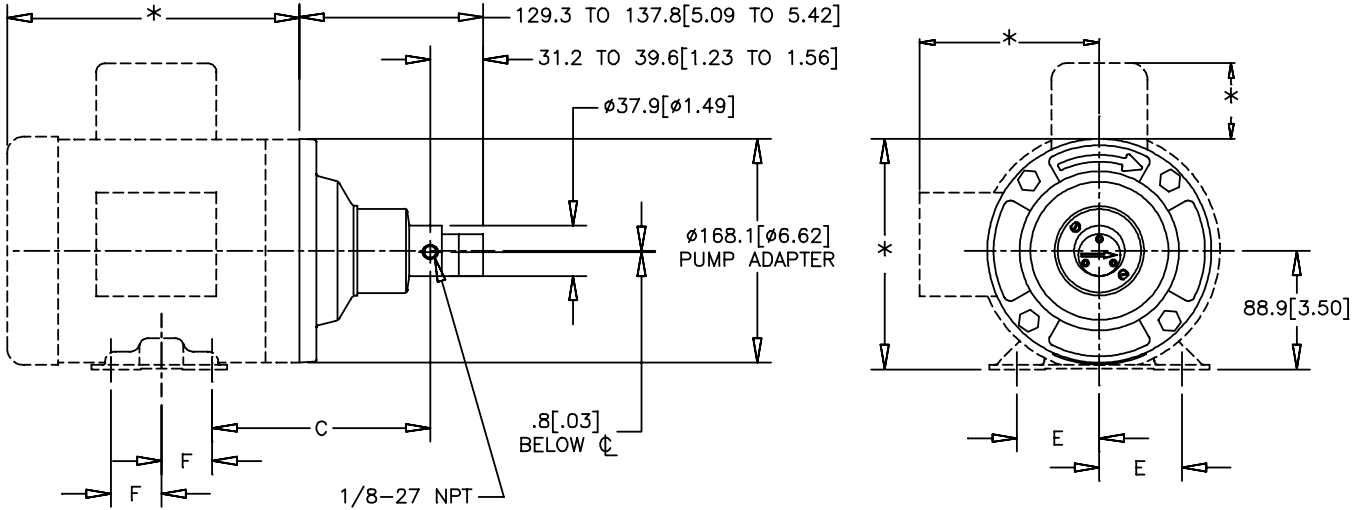

MOUNT	C mm [in]	E mm [in]	F mm [in]
NEMA ^E 56C	163.4 [6.43]	61.9 [2.44]	38.1 [1.50]
NEMA ^K 143TC	158.5 [6.24]	69.9 [2.75]	50.8 [2.00]
NEMA ^K 145TC	158.5 [6.24]	69.9 [2.75]	63.5 [2.50]

NOTES:

- *THESE DIMENSIONS WILL VARY BASED ON MOTOR SELECTION.
- ALL DIMENSIONS ARE NOMINAL.

ACTUAL PERFORMANCE MAY VARY - Specifications are subject to change without notice. When multiple specs are noted, the most conservative value applies.

USA: Micropump, Inc., A Unit of IDEX Corporation • Phone 360.253.2008 • Fax 360.253.2401
 UK: Micropump, Ltd., A Subsidiary of Micropump, Inc. • Phone +44 (1480) 356900 • Fax +44 (1480) 356920
 info@micropump.com www.micropump.com

Order Code				Pump Construction			
Base Code		Gear Set		Drive Mount		Options	
G	J	-	N27			6	
1	2	3	4	5	6	7	8
Model				Wetted Materials			
				O/C: Pump S/K: Service Kit			
				Magnetic Drive Gear Pump Cavity Style Two Helical, Shafted Gears/DP24 Sleeve Bushings/Gasket Seals (2) PTFE Bevel or O-Ring Seal (1) PPS Driven Magnet			



Dimensions

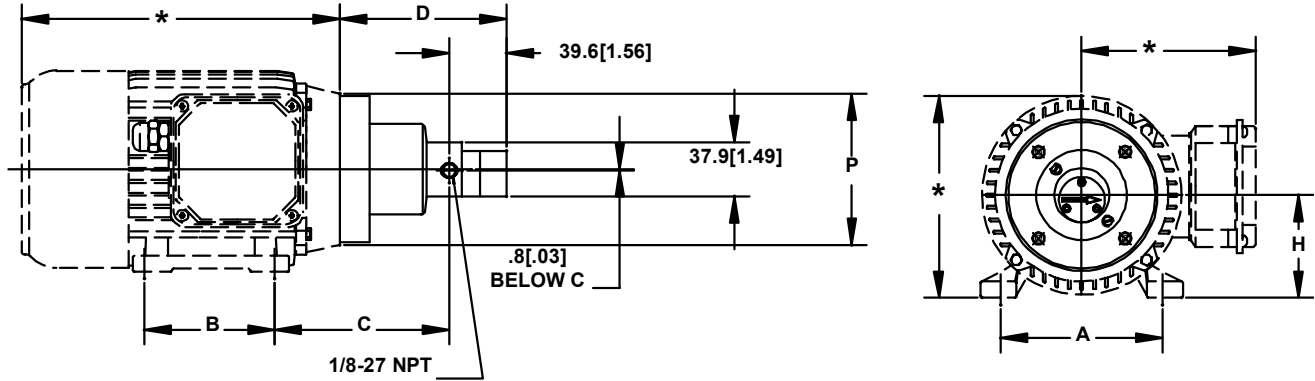

MOUNT	A mm [in]	B mm [in]	C mm [in]	D mm [in]	H mm [in]	P mm [in]
2 IEC56B14B3	90 [3.54]	71 [2.80]	99.2 [3.90]	94.5 [3.72] TO 102.8 [4.05]	56 [2.20]	80 [3.15]
4 IEC63B14B3	100 [3.94]	80 [3.15]	108.8 [4.28]	100.1 [3.94] TO 108.5 [4.27]	63 [2.48]	90 [3.54]
6 IEC71B14B3	112 [4.41]	90 [3.54]	120.8 [4.76]	107.1 [4.22] TO 115.5 [4.55]	71 [2.80]	105 [4.13]

NOTES:

- *THESE DIMENSIONS WIL VARY BASED ON MOTOR SELECTION.
- ALL DIMENSIONSARE NOMINAL.

AUSTRALIAN DISTRIBUTOR



CALL 1300 789 466
When Pump Knowledge Matters
www.kelairpumps.com.au

ACTUAL PERFORMANCE MAY VARY - Specifications are subject to change without notice. When multiple specs are noted, the most conservative value applies.

USA: Micropump, Inc., A Unit of IDEX Corporation • Phone 360.253.2008 • Fax 360.253.2401
UK: Micropump, Ltd., A Subsidiary of Micropump, Inc. • Phone +44 (1480) 356900 • Fax +44 (1480) 356920
info@micropump.com www.micropump.com