

PulsaPro® 7120

HYDRAULIC DIAPHRAGM METERING PUMP

PulsaPro® 7120 is a positive displacement, leak-free, hydraulically balanced diaphragm metering pump, engineered for precise dosing and long-term dependability, delivering superior value.

It offers a diverse range of fluid handling solutions with unique wet end designs consisting of HYDRAtube® or flat diaphragm types, each available in a variety of wet-end materials. PP7120 features immediate visual intelligence about pump and system performance. It complies with the API 675 standard for use in oil & gas, petrochemical, chemical processing, power generation, and water & wastewater treatment industries. Certified by WQA as “NSF/ANSI 61” compliant for use in drinking water treatment processes.



Common Applications

- corrosion inhibitors
- anti-scalants
- odor control
- Disinfection with Sodium Hypochlorite
- pH control with lime slurries



Flow

up to 243 gph (920 lph)



Pressure

up to 3,100 psi (213.7 bar)



Fluid Temperature

up to 250°F (121°C)



API 675, CE,
ATEX, IECEx



“NSF/ANSI/CAN 61”
“NSF/ANSI/372”



Standard materials of construction

- Wet end: 316LSS, GF-PTFE, PVC
- Diaphragm: PTFE, Hypalon* or Viton*
- Valve ball: 316LSS, Alumina Ceramic
- Valve seat: 316LSS, PVC, GF-PTFE
- Valve gaskets: PTFE, Hypalon* or Viton*
- Pump body: Cast Iron

Connection types

- NPT
- Raised-face flange

Controls

- Manual stroke length control
- Electronic stroke length control

Leak detection

- PULSAAlarm®
 - Pressure based
 - IP66, NEMA Type 4X, NEMA TYPE 7

Automatic degassing

- Hypo Valve
 - Automatic purging of trapped gasses
 - Integrated Design
 - Use with Sodium Hypochlorite

Multiplex configurations

- up to 17 pumps

HYDRAtube design

- The solution for shear sensitive and high viscosity fluids
- Straight flow-through path
- Double diaphragm safety
- Optional slurry valves
- Robust Ductile Iron housing
- Elastomeric HYDRAtube
- ChemAlarm® leak detection

* HYDRAtube only

 **PULSAFEEDER®**
ENGINEERED PRODUCTS

DIMENSIONS

Approximate shipping weight: 110 lb. (50 kg.)

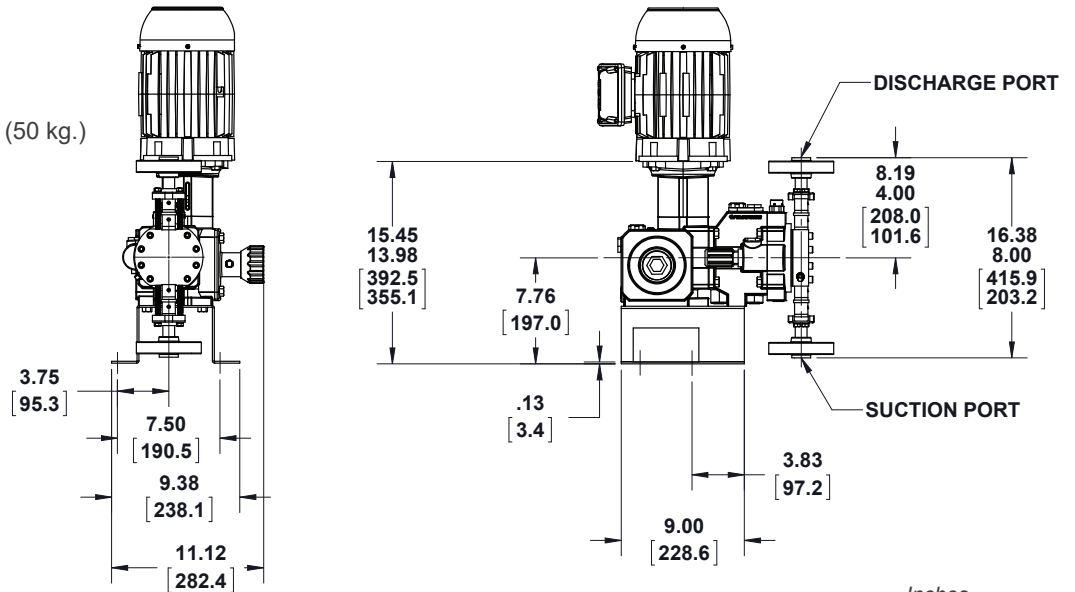

Inches
[Millimeters]

The dimensions given may differ depending on pump configuration.

SPECIFICATIONS

Materials	316LSS, PVC, GF-PTFE	Accuracy	±0.5%	
Diaphragm type	Flat, Tube	Temperature limitations	Min	Max
Motor power	up to 1.5 hp (1.1 kW)	Standard Fluid temp. range	-10°F (-23°C)	250°F (121°C)
Motor frame	NEMA 56C, 143/5TC, 182/4TC IEC 71B14, 80B14, 90B14	Ambient temp. limit with ATEX	-4°F (-20°C)	174°F (79°C)
Standards	API 675, CE, ATEX, IECEx, "NSF/ANSI 61"			

FEATURES & BENEFITS

- Unique 3 valve hydraulic management system makes the PulsaPro pump resilient to system upset
- **Hydraulic performance valve** maintains optimum diaphragm position and allows low NPIP of 5 psi (0.31 bar)
- **Push-to-prime valve** allows quick manual priming of the hydraulic system in addition to automatic air bleeding
- Externally adjustable **hydraulic by-pass valve** protects against over-pressurization
- Four bolt tie bar design provides ultimate resistance to piping moments and forces
- Three component check valves for controlled fluid displacement, assuring reliable hydraulic operation
- Manual stroke length adjustment with resolution of 0.1% for set point accuracy and optional electronic stroke length adjustment with 5x improved resolution

FLOW & PRESSURE ENVELOPE

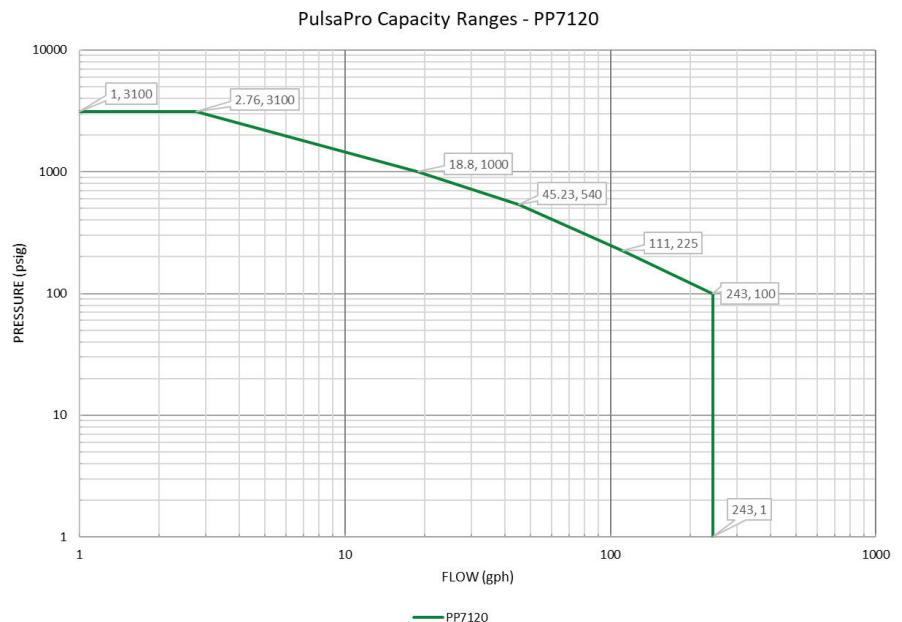

CUSTOM ENGINEERING

- Compatible materials: Alloy C, Alloy 20, Monel®, DuplexSS, Titanium, PVDF
- Minimum temperature to -10°F (-23°C) and with ATEX to -4°F (-20°C)
- Degass Valve
- Chemical feed systems
- Application consulting

AUSTRALIAN DISTRIBUTOR



CALL 1300 789 466
When Pump Knowledge Matters
www.kelairpumps.com.au

pulsa7120spec_Rev0321