

MOTOR SPEED PRODUCT LINE: STEEL EXTERNALS PUMPS

SERIES 493, 4193

Section	1341
Page	1341.1
Issue	C

TABLE OF CONTENTS

Features & Benefits	2
Specifications	2
Standard Materials of Construction	2
Model Number Key	3
Cutaway View & Pump Features	3
Mounting Options	4
Dimensions – GG, HJ, HL Sizes (493)	5
Dimensions – AS, AK, AL Sizes (493)	5
Dimensions – GG, HJ, HL Sizes (4193)	6
Dimensions – AS, AK, AL Sizes (4193)	6
Dimensions – GG, HJ, HL, AS, AK, AL Sizes – IM Drive (493) ...	7
Dimensions – GG, HJ, HL Sizes – NEMA C M Drive (493)	8
Dimensions – AS, AK, AL Sizes – NEMA C M Drive (493)	9
Dimensions – HJ, HL Sizes – IEC Frame M Drive (493)	9
Dimensions – GG, HJ, HL, AS, AK, AL Sizes – D Drive (4193) .	10
NPSH Required	11

SERIES DESCRIPTION

Viking's Motor Speed Product Line Series 493 and 4193 steel external pumps are available in capacities up to 75 GPM. These pumps can be furnished directly connected to a 50HZ or 60 HZ motor.

Series 493 is designed for vertical or horizontal flange mount installations where space is at a premium. Series 4193 is designed for foot type horizontal mounting. These pumps are built for continuous or intermittent duty for such applications as filtering, circulating, transferring, or booster service in general industrial, petrochemical and other industries.

They are furnished as standard with mechanical seal construction to minimize liquid loss and for shaft protection. The thrust control provides micrometer adjustments for accurate rotor and shaft positioning to help you keep operating with new-pump efficiency through years of heavy duty service.

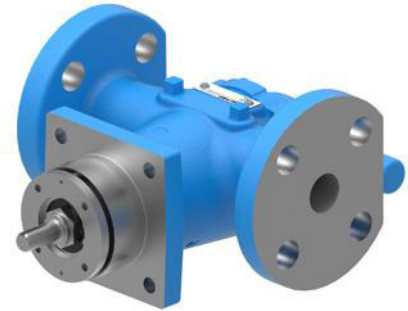

GG493

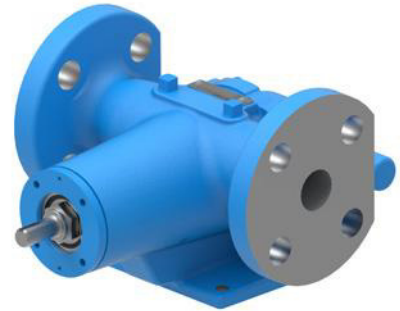

GG4193

RELATED PRODUCTS

Cast Iron, 495/4195 Series: Catalog Section 1441

Stainless Steel, 4197 Series: Catalog Section 1741

OPERATING RANGE

SERIES	NOMINAL FLOW		MAXIMUM PRESSURE*		TEMPERATURE RANGE		VISCOSITY RANGE	
	GPM	m ³ h	PSI	Bar	°F	°C	SSU	cSt
493	7 - 75	1.5 - 17	250	17	0 to +350	-20 to +175	28 to 15,000	1 to 3,300
4193	7 - 75	1.5 - 17	250	17	0 to +350	-20 to +175	28 to 15,000	1 to 3,300

* 250 PSI (17 BAR) for above 100 SSU (20 cSt), 150 PSI (17 BAR) for 38 to 100 SSU (3 to 20 cSt), 100 PSI (7 BAR) for below 38 SSU (3 cSt)

Section	1341
Page	1341.2
Issue	C

**MOTOR SPEED PRODUCT LINE:
STEEL EXTERNALS PUMPS
SERIES 493, 4193**

FEATURES & BENEFITS

- Ball Bearings Standard
 - » Pumps are equipped with inner casing ball bearing installed outside of mechanical seal and a radial thrust ball bearing permitting heavy-duty service up to 250 PSI (17 BAR). Bearings are “Sealed for Life”.
- Integral Over-Pressure Relief Valve Standard
 - » Permits bypassing of liquid from discharge to suction side of pump. Prevents build up of pressure in discharge line. GG, HJ and HL size valve mounts on pump head. AS, AK and AL size valve mounts on pump casing.
- O-Ring Gaskets Standard
 - » O-Ring gaskets are used between casing and head plate and between casing and relief valve or valve plates. Flat valve gaskets furnished on GG, HJ and HL size pumps. These gaskets provide a positive seal eliminating a chance for leak-age at these points.
- Ductile Iron Parts Standard on AS, AK & AL Sizes
 - » Internal pumping gears (rotor and idler) are constructed of ductile iron for added strength in handling all types of liquids up to 15,000 SSU (3,300 cSt). HL size rotor also furnished in ductile iron.

STANDARD MATERIALS OF CONSTRUCTION

Component		Standard Material
Casing		Steel, ASTM A216, Grade WCB
Head		Steel, ASTM A216, Grade WCB
Rotor Shaft		Steel, ASTM A108, Grade 1045
Rotor	GG, HJ	Cast Iron, ASTM A48, Class 35B
	HL, AS, AK, AL	Ductile Iron, ASTM A536, Grade 60-40-18
Idler	GG, HJ, HL	Steel (Powdered Metal) GG: MPIF 35, FN-0208-45 HJ, HL: MPIF 35, FC-0208-50
	AS, AK, AL	Ductile Iron, ASTM A536, Grade 60-40-18
Idler Pin		Hardened Steel, ASTM A108, Grade 1045
Idler Bushing		Carbon Graphite
Pressure Relief Valve		Steel Externals, ASTM A216, Grade WCB
Mounting Bracket (Units Only)		Cast Iron
Seal		Fluoroelastomer (FKM), Carbon / Silicon Carbide

SPECIFICATIONS

Model Number	Standard Ports		Nominal Pump Rating (100 SSU & below)						① Maximum Differential Pressure*		③ Maximum Hydrostatic Pressure		② Maximum Temperature		Approximate Shipping Weight with Valve	
	Port Size Inches	Port Type	60 Hz			50 Hz			PSIG	BAR	PSIG	BAR	°F	°C	Lbs.	Kg.
			GPM	m ³ /h	RPM	GPM	m ³ /h	RPM								
GG4193	1	Class 300	10	2.3	1750	8	1.9	1450	250	17	400	27	350	175	25	11
GG493	1	Class 300	10	2.3	1750	8	1.9	1450	250	17	400	27	350	175	18	8
HJ4193	1½	Class 300	20	4.5	1750	17	3.8	1450	250	17	400	27	350	175	50	23
HJ493	1½	Class 300	20	4.5	1750	17	3.8	1450	250	17	400	27	350	175	40	18
HL4193	1½	Class 300	30	6.8	1750	25	5.6	1450	250	17	400	27	350	175	50	23
HL493	1½	Class 300	30	6.8	1750	25	5.6	1450	250	17	400	27	350	175	40	18
AS4193	3	Class 300	35	8	1150	45	10	1450	250	17	400	27	350	175	100	45
AS493	3	Class 300	35	8	1150	45	10	1450	250	17	400	27	350	175	80	36
AK4193	3	Class 300	50	11	1150	70	16	1450	250	17	400	27	350	175	100	45
AK493	3	Class 300	50	11	1150	70	16	1450	250	17	400	27	350	175	80	36
AL4193	3	Class 300	75	17	1150	95	22	1450	250	17	400	27	350	175	102	46
AL493	3	Class 300	75	17	1150	95	22	1450	250	17	400	27	350	175	81	37

① If suction pressure exceeds 100 PSI (7 BAR), consult factory.

② Standard FKM seal from 0°F to +350°F (-20°C to +175°C). Extra clearances are required above 225°F (105°C).

③ Maximum hydrostatic pressure for standard pump construction. Rating is dependent on seal, gaskets and ports.

* 250 PSI (17 BAR) for above 100 SSU (20 cSt), 150 PSI (10 BAR) for 38 to 100 SSU (3 to 20 cSt), 100 PSI (7 BAR)) for below 38 SSU (3 cSt)

MOTOR SPEED PRODUCT LINE: STEEL EXTERNALS PUMPS

SERIES 493, 4193

Section	1341
Page	1341.3
Issue	C

MODEL NUMBER KEY

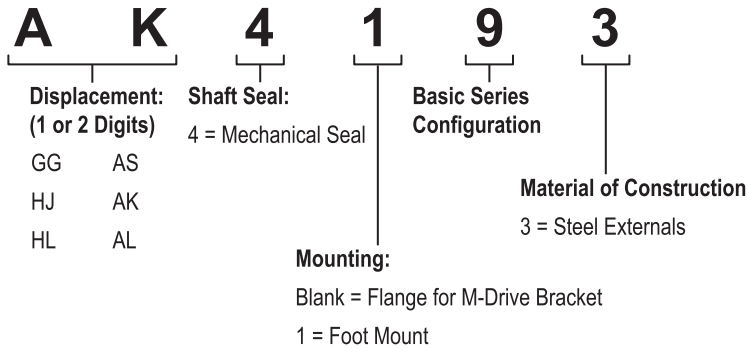

CUTAWAY VIEW & PUMP FEATURES

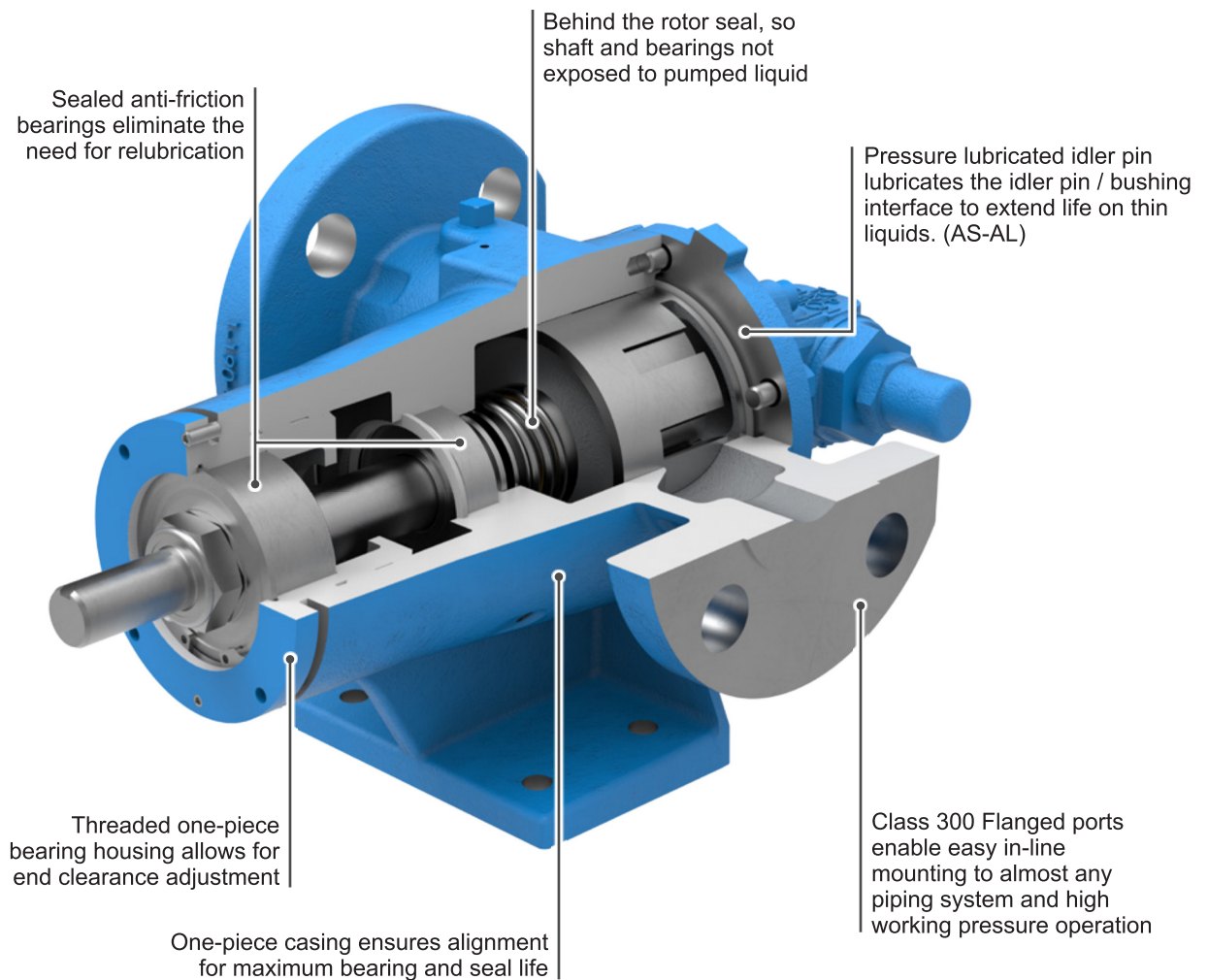

* Shown with raised face flange option

Section	1341
Page	1341.4
Issue	C

**MOTOR SPEED PRODUCT LINE:
STEEL EXTERNALS PUMPS
SERIES 493, 4193**

MOUNTING OPTIONS

Flange Motor Mount Units (M Drive)

Pump and motor mounted to a flange mounting bracket with coupling.

Sizes: GG - AL493

For more compact horizontal mounting, the “C” face mounted Series 493 Heavy-Duty pump units in all six sizes include a combination motor “C” flange and square pump flange bracket with coupling connecting motor and pump. The three smaller units connect to a foot mounted motor, while the three larger units include a foot type bracket to mount a flange type motor.

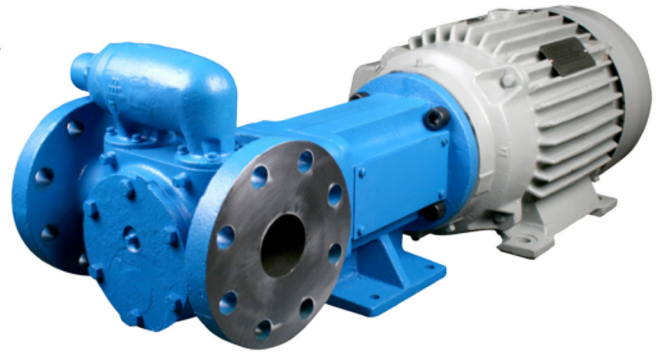

Vertically Inline Mounted (IM Drive)

Pump and motor vertically mounted to a flange mounting bracket with coupling.

Sizes: GG - AL493

Viking’s Series 493 pump line can be mounted either vertically or horizontally to electric motors. Vertical inline mounted unit described on this page comes complete with footless “C” flange mounting bracket and coupling between motor and pump.

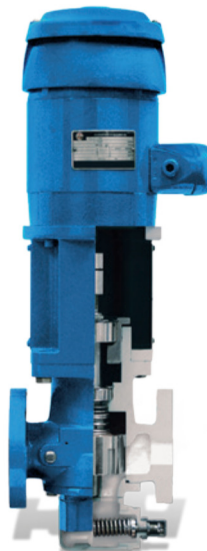

Direct Drive (D Drive)

Pump and motor mounted on a base with coupling and coupling guard.

Sizes: GG - AL4193

Series 4193 units in the “GG”, “HJ” and “HL” size (nominal rating 10, 20, 30 GPM) are designed for high-speed, heavy-duty service. The pump is connected by a flexible coupling with guard directly to a 50 HZ or 60 HZ motor. Both pump and motor mount on a sturdy formed steel base. This makes a very compact, rugged unit for heavy-duty service, handling many types of liquids up to 15,000 SSU (3,300 cSt).

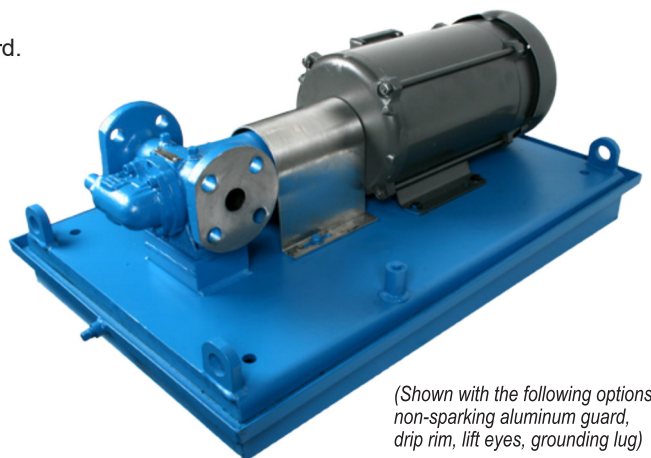

*(Shown with the following options:
non-sparking aluminum guard,
drip rim, lift eyes, grounding lug)*

MOTOR SPEED PRODUCT LINE: STEEL EXTERNALS PUMPS

SERIES 493, 4193

Section	1341
Page	1341.5
Issue	C

DIMENSIONS – GG, HJ, HL SIZES (493)

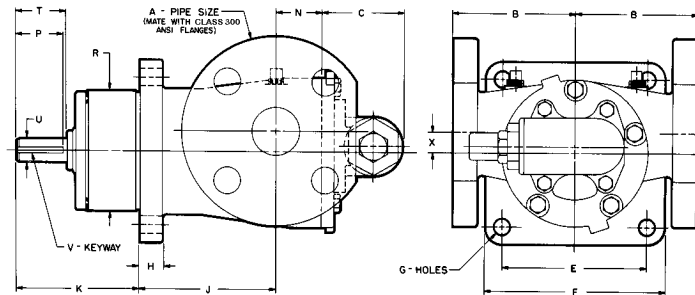

Model Number	A (in)		B	C	E	F	G	H	J	K	N	P	R	T	U (in)	V (in)	X
GG493	1	in	4.00	2.66	3.00	4.00	0.41	0.62	3.44	2.81	1.12	0.94	2.88	1.12	0.50	.12 x .06	0.62
		mm	102	67	76	102	10	16	87	71	29	24	73	29			
HJ493	1½	in	4.00	2.84	4.75	5.88	0.56	0.75	4.50	4.00	1.50	1.50	3.88	1.62	0.75	.19 x .09	0.62
		mm	102	72	121	149	14	19	114	102	38	38	98	41			
HL493	1½	in	4.00	2.84	4.75	5.88	0.56	0.75	4.50	4.00	1.50	1.50	3.88	1.62	0.75	.19 x .09	0.62
		mm	102	72	121	149	14	19	114	102	38	38	98	41			

DIMENSIONS – AS, AK, AL SIZES (493)

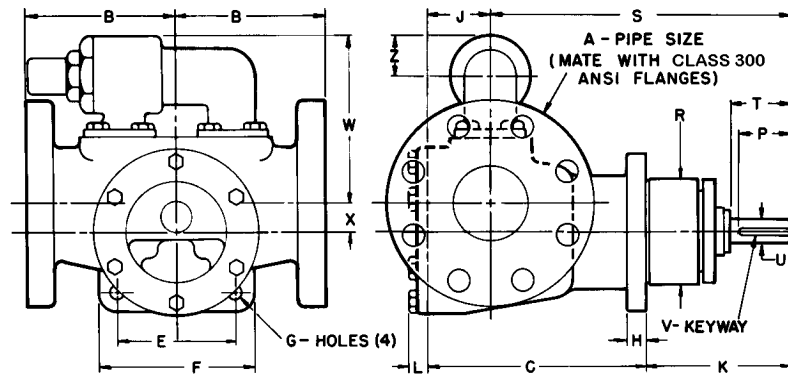

Model Number	A (in)		B	C	E	F	G	H	J	K	L	P	R	S	T	U (in)	V (in)	W	X	Z
AS493	3	in	6	8.38	4.75	6.25	0.56	0.75	2	5.75	0.88	2.25	4.25	12.12	2.5	1	.25 x .12	7	1.12	1.56
		mm	152	213	121	159	14	19	51	146	22	57	108	308	64					
AK493	3	in	6	8.38	4.75	6.25	0.56	0.75	2	5.75	0.88	2.25	4.25	12.12	2.5	1	.25 x .12	7	1.12	1.56
		mm	152	213	121	159	14	19	51	146	22	57	108	308	64					
AL493	3	in	6	8.88	4.75	6.25	0.56	0.75	2.5	5.75	0.88	2.25	4.25	12.12	2.5	1	.25 x .12	7	1.12	1.56
		mm	152	225	121	159	14	19	64	146	22	57	108	308	64					

These dimensions are average and not for construction purposes. Certified prints on request.

Section	1341
Page	1341.6
Issue	C

**MOTOR SPEED PRODUCT LINE:
STEEL EXTERNALS PUMPS
SERIES 493, 4193**

DIMENSIONS – GG, HJ, HL SIZES (4193)

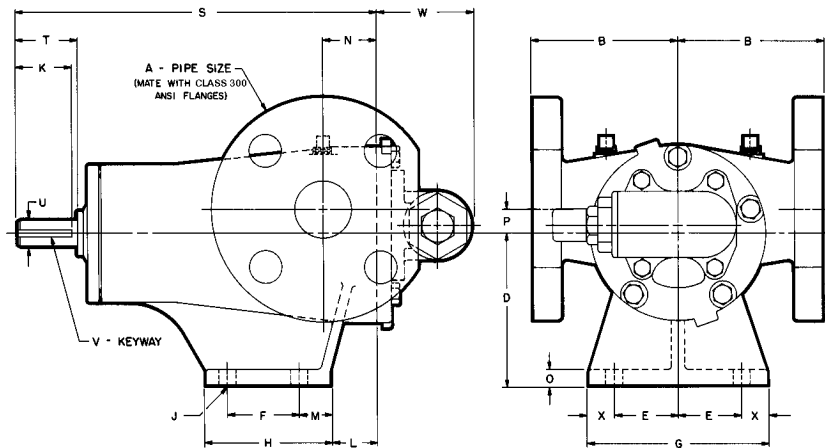

Model Number	A (in)	B	D	E	F	G	H	J	K	L	M	N	O	P	S	T	U (in)	V (in)	W	X	
GG4193	1	in	4.00	2.75	1.62	1.31	4.00	2.44	0.34	0.94	0.03	0.66	1.12	0.31	0.62	7.31	1.12	0.50	.12 x .06	2.66	0.38
	mm	102	70	41	33	102	62	9	24	1	17	29	8	16	186	29	67			10	
HJ4193	1½	in	4.00	4.12	1.75	2.00	5.00	3.50	0.41	1.50	1.25	0.88	1.50	0.44	0.62	10.00	1.62	0.75	.19 x .09	2.84	0.75
		mm	102	105	44	51	127	89	10	38	32	22	38	11	16	254	41			72	19
HL4193	1½	in	4.00	4.12	1.75	2.00	5.00	3.50	0.41	1.50	1.25	0.88	1.50	0.44	0.62	10.00	1.62	0.75	.19 x .09	2.84	0.75
		mm	102	105	44	51	127	89	10	38	32	22	38	11	16	254	41			72	19

DIMENSIONS – AS, AK, AL SIZES (4193)

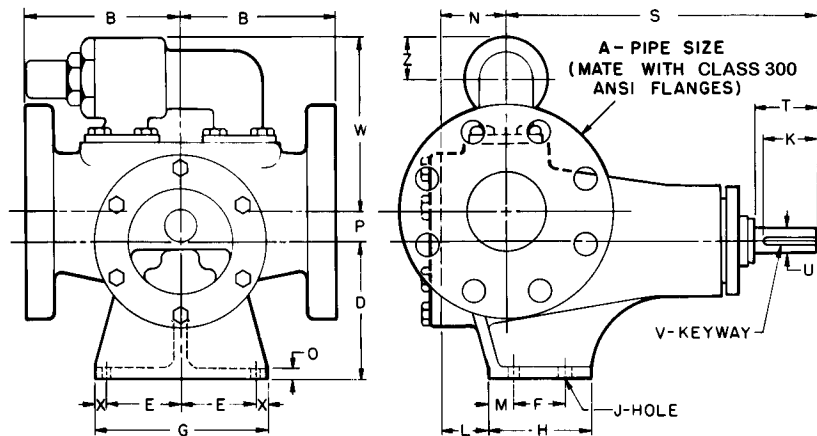

Model Number	A (in)	B	D	E	F	G	H	J	K	L	M	N	O	P	S	T	U (in)	V (in)	W	X	Y	Z	
AS4193	3	in	6.00	5.25	2.88	2.00	6.75	4.00	0.41	2.25	1.25	1.00	2.00	0.44	1.12	12.12	2.38	1.00	.25 x .12	7.00	0.50	1.56	1.72
	mm	152	133	73	51	171	102	10	57	32	25	51	11	29	308	60	178			13	40	40	
AK4193	3	in	6.00	5.25	2.88	2.00	6.75	4.00	0.41	2.25	1.25	1.00	2.00	0.44	1.12	12.12	2.38	1.00	.25 x .12	7.00	0.50	1.56	1.72
		mm	152	133	73	51	171	102	10	57	32	25	51	11	29	308	60			178	13	40	40
AL4193	3	in	6.00	5.25	2.88	2.00	6.75	4.00	0.41	2.25	1.75	1.00	2.50	0.44	1.12	12.12	2.38	1.00	.25 x .12	7.00	0.50	1.56	1.72
		mm	152	133	73	51	171	102	10	57	44	25	64	11	29	308	60			178	13	40	40

These dimensions are average and not for construction purposes. Certified prints on request.

MOTOR SPEED PRODUCT LINE: STEEL EXTERNALS PUMPS

SERIES 493, 4193

Section	1341
Page	1341.7
Issue	C

DIMENSIONS – GG, HJ, HL, AS, AK, AL SIZES – IM DRIVE (493)

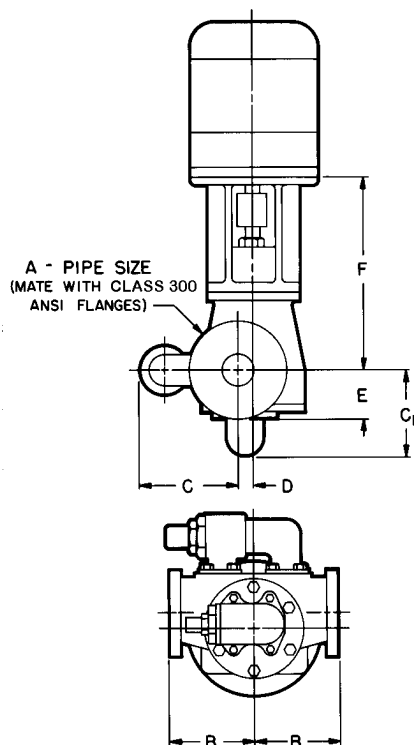

MODEL	A (in)		B	C	C ₁	D	E	MOTOR FRAME	F
GG493	1	in	4.00	—	3.78	0.62	2.44	56C	8.88
		mm	102	—	96	16	62	143TC 145TC	225
	1	in	4.00	—	3.78	0.62	2.44	182TC	9.56
		mm	102	—	96	16	62	184TC	243
HL493	1½	in	4.00	—	4.34	0.62	3.06	56C	11.12
		mm	102	—	110	16	78	143TC 145TC	283
	1½	in	4.00	—	4.34	0.62	3.06	182TC	11.81
		mm	102	—	110	16	78	184TC	300
	1½	in	4.00	—	4.34	0.62	3.06	213TC	12.56
		mm	102	—	110	16	78	215TC	319
AS493 AK493 AL493	3	in	6.00	7.00	—	1.12	4.12	182TC 184TC 213TC	① 16.19"
		mm	152	178	—	29	105	215TC 254TC 256TC	411

① Dimensions are correct for 182TC through 215TC motors.
For 254TC/256TC motors, add .88" to the dimensions shown.

NOTE: Jaw type coupling with straight jaws recommended
to facilitate assembly of motor and pump to bracket.

COUPLING IS GUARDED WITH PLATES OVER SIDE OPENINGS ON MOUNTING BRACKET.

These dimensions are average and not for construction purposes. Certified prints on request.

VIKING PUMP • A Unit of IDEX Corporation • Cedar Falls, IA ©2018

Section	1341
Page	1341.8
Issue	C

**MOTOR SPEED PRODUCT LINE:
STEEL EXTERNALS PUMPS
SERIES 493, 4193**

DIMENSIONS – GG, HJ, HL SIZES – NEMA C M DRIVE (493)

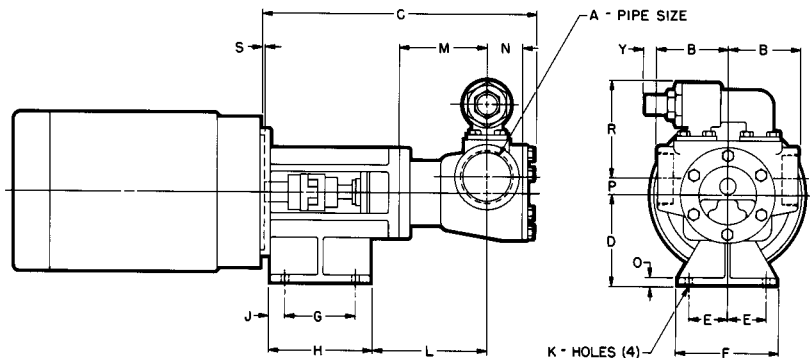

Model Number	A (in)		B	C	J	L	M	N	MOTOR FRAME	D	E	F	G	H	K	
GG493	1	in	4.00	2.66	3.44	0.62	0.19	1.12	56C	3.50	2.44	1.50	2.56	8.88	.34 SLOT	
		mm	102	67	87	16	5	29		89	62	38	65	225	9	
	1	in	4.00	2.66	3.44	0.62	0.19	1.12	143TC	3.50	2.75	2.00	2.88	8.88	0.34	
		mm	102	67	87	16	5	29		89	70	51	73	225	9	
	1	in	4.00	2.66	3.44	0.62	0.19	1.12	145TC	3.50	2.75	2.50	2.88	8.88	0.34	
		mm	102	67	87	16	5	29		89	70	64	73	225	9	
	1	in	4.00	2.66	3.44	0.62	0.19	1.12	182TC	4.50	3.75	2.25	3.44	9.56	0.41	
		mm	102	67	87	16	5	29		114	95	57	87	243	10	
	1	in	4.00	2.66	3.44	0.62	0.19	1.12	184TC	4.50	3.75	2.75	3.44	9.56	0.41	
		mm	102	67	87	16	5	29		114	95	70	87	243	10	
	HJ493 HL493	1½	in	4.00	2.84	4.50	0.62	0.19	1.50	56C	3.50	2.44	1.50	2.56	11.12	.34 SLOT
			mm	102	72	114	16	5	38		89	62	38	65	283	9
1½		in	4.00	2.84	4.50	0.62	0.19	1.50	143TC	3.50	2.75	2.00	2.88	11.12	0.34	
		mm	102	72	114	16	5	38		89	70	51	73	283	9	
1½		in	4.00	2.84	4.50	0.62	0.19	1.50	145TC	3.50	2.75	2.50	2.88	11.12	0.34	
		mm	102	72	114	16	5	38		89	70	64	73	283	9	
1½		in	4.00	2.84	4.50	0.62	0.19	1.50	182TC	4.50	3.75	2.25	3.44	11.81	0.41	
		mm	102	72	114	16	5	38		114	95	57	87	300	10	
1½		in	4.00	2.84	4.50	0.62	0.19	1.50	184TC	4.50	3.75	2.75	3.44	11.81	0.41	
		mm	102	72	114	16	5	38		114	95	70	87	300	10	
1½		in	—	—	—	—	—	—	213TC	5.25	4.25	2.75	4.50	12.56	0.41	
		mm	—	—	—	—	—	—		133	107	70	114	319	10	
1½		in	—	—	—	—	—	—	215TC	5.25	4.25	3.50	4.50	12.56	0.41	
		mm	—	—	—	—	—	—		133	107	89	114	319	10	

NOTE: Jaw type coupling with straight jaws recommended to facilitate assembly of motor and pump to bracket.
COUPLING IS GUARDED WITH PLATES OVER SIDE OPENINGS ON MOUNTING BRACKET.

These dimensions are average and not for construction purposes. Certified prints on request.

MOTOR SPEED PRODUCT LINE: STEEL EXTERNALS PUMPS

SERIES 493, 4193

Section	1341
Page	1341.9
Issue	C

DIMENSIONS – AS, AK, AL SIZES – NEMA C M DRIVE (493)

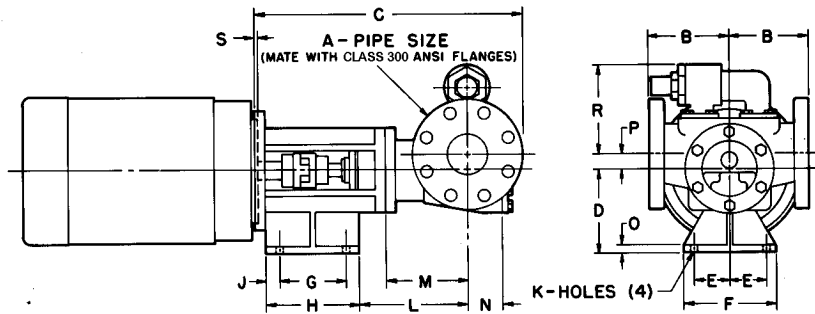

Model Number	A (in)		B	① C	D	E	F	G	H	J	K	① L	M	N	O	P	R	S
AS493	3	in	6.00	20.31	6.25	2.75	7.00	5.00	7.00	1.00	0.56	8.44	6.38	2.00	0.50	1.12	7.00	0.19
		mm	152	516	159	70	178	127	178	25	14	214	162	51	13	29	178	5
AK493	3	in	6.00	20.31	6.25	2.75	7.00	5.00	7.00	1.00	0.56	8.44	6.38	2.00	0.50	1.12	7.00	0.19
		mm	152	516	159	70	178	127	178	25	14	214	162	51	13	29	178	5
AL493	3	in	6.00	20.31	6.25	2.75	7.00	5.00	7.00	1.00	0.56	8.44	6.38	2.50	0.50	1.12	7.00	0.19
		mm	152	516	159	70	178	127	178	25	14	214	162	64	13	29	178	5

① Dimensions are correct for 182TC through 215TC motors. For 254TC/256TC motors, add .88" to the dimensions shown.

NOTE: Jaw type coupling with straight jaws recommended to facilitate assembly of motor and pump to bracket.

COUPLING IS GUARDED WITH PLATES OVER SIDE OPENINGS ON MOUNTING BRACKET.

DIMENSIONS – HJ, HL SIZES – IEC FRAME M DRIVE (493)

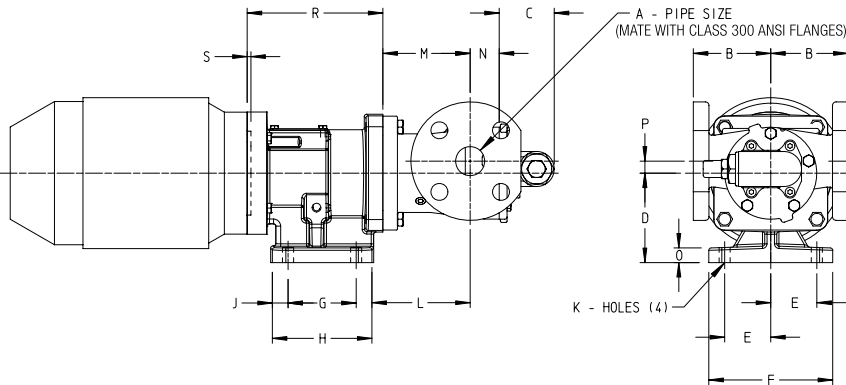

Brackets are designed for IEC motors with B14 mounting face.

NOTE: Jaw type coupling with straight jaws recommended to facilitate assembly of motor and pump to bracket.

COUPLING IS GUARDED WITH PLATES OVER SIDE OPENINGS ON MOUNTING BRACKET.

MODEL		A (in)	B	C	M	N	P	MOTOR FRAME	D	E	F	G	H	J	K	L	O	R	S
HJ493	in	1½	4.00	2.84	4.50	1.50	0.62	IEC 90	4.62	2.38	6.40	3.52	5.32	0.90	0.57	4.83	0.75	6.61	0.19
	mm		102	72	114	38	16		117	61	163	89	135	23	15	123	19	168	5
HL493	in		4.00	2.84	4.50	1.50	0.62	IEC 100/112	4.62	2.38	6.40	3.52	5.32	0.90	0.57	5.01	0.75	7.01	0.19
	mm		102	72	114	38	16		117	61	163	89	135	23	15	127	19	178	5
	in		4.00	2.84	4.50	1.50	0.62	IEC 132	5.32	2.95	7.48	4.50	6.31	0.90	0.57	4.94	0.75	8.16	0.25
	mm		102	72	114	38	16		135	75	190	114	160	23	15	125	19	207	6

These dimensions are average and not for construction purposes. Certified prints on request.

Section	1341
Page	1341.10
Issue	C

**MOTOR SPEED PRODUCT LINE:
STEEL EXTERNALS PUMPS
SERIES 493, 4193**

DIMENSIONS – GG, HJ, HL, AS, AK, AL SIZES – D DRIVE (4193)

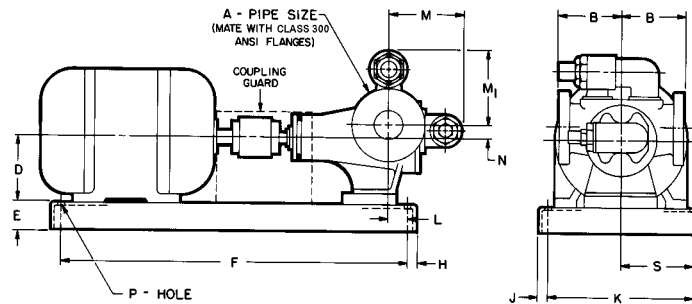

Model	Motor		A (in)	B	D	E	F	H	J	K	L	M	M ₁	N	P	S
GG4193D	NEMA 56	in	1	4.00	① 3.50	1.50	20.50	0.75	0.75	8.50	0.38	3.78	—	0.62	0.62	4.25
		mm		102	89	38	521	19	19	216	10	96		16	16	108
HJ4193 HL4193	NEMA 56	in	1½	4.00	② 3.50	⑥ 2.12	20.50	0.75	0.75	8.50	0	4.34	—	0.62	0.62	4.25
		mm		102	89	54	521	19	19	216	0	110		16	16	108
	NEMA 143/145	in	1½	4.00	③ 4.50	2.94	29.00	1.00	1.50	9.00	0.25	4.34		0.62	0.62	4.50
		mm		102	114	75	737	25	38	229		110		16	16	114
	NEMA 254/256	in	1½	4.00	④ 5.25	2.94	29.00	1.00	1.50	9.00	0.25	4.34		0.62	0.62	4.50
		mm		102	133	75	737	25	38	229		110		16	16	114
AS4193 AK4193 AL4193	NEMA 143/145T	in	3	6.00	③ 4.50	⑦ 3.69	29.00	1.00	1.50	9.00	0	—	7.00	1.12	0.62	4.50
		mm		152	114	94	737	25	38	229	0		178	29	16	114
	NEMA 182/184	in	3	6.00	④ 5.25	2.94	34.00	1.00	1.50	9.00	0		7.00	1.12	0.62	4.50
		mm		152	133	75	864	25	38	229	0		178	29	16	114
	NEMA 284/286	in	3	6.00	⑤ 6.25	4.00	39.00	1.38	1.38	16.00	3.75		7.00	1.12	0.62	8.00
		mm		152	159	102	991	35	35	406	95		178	29	16	203

- ① 56, 143T and 145T frame motors. (Available with "GG" size pump.)
- ② 56, 143T and 145T frame motors. (Available with "HJ" or "HL" size pumps.)
- ③ 182, 182T, 184, 184T frame motors. (Available with "HJ" thru "AL" size pumps.)
- ④ 213, 213T, 215, 215T frame motors. (Available with "HJ" thru "AL" size pumps.)
- ⑤ 254U, 254T, 256U, 256T frame motors. (Available with "AK" thru "AL" size pumps.)
- ⑥ Dimension includes motor block, base height is 1½".
- ⑦ Dimension includes motor block, base height is 2 15/16".

These dimensions are average and not for construction purposes. Certified prints on request.

MOTOR SPEED PRODUCT LINE: STEEL EXTERNALS PUMPS

SERIES 493, 4193

Section	1341
Page	1341.11
Issue	C

PSH REQUIRED

Printed performance curves are not available.

Performance curves can be electronically generated with the Viking Pump Curve Generator on vikingpump.com.

NPSHR data is not available on the curve generator.

PSH (Net Positive Suction Head): The NPSH_R (Net Positive Suction Head Required by the pump) is given in the table below and applies for viscosities through 750 SSU. NPSH_A (Net Positive Suction Head – Available in the system) must be greater than the NPSH_R. For a complete explanation of NPSH, see Application Data Sheet AD-19.

FOR VISCOSITIES UP TO 750 SSU – See NPSH_R table below.

NPSH_R for high viscosities can be estimated using the following method:

1. Calculate line loss for a 1 foot long pipe of a diameter matching the pump inlet port size. Use your flow rate and max viscosity.
2. Convert this value into Feet of Liquid (S.G. 1.0)
3. Add this value to the NPSH_R value in the chart below.

PUMP SIZE	PUMPS SPEED, RPM						
	520	640	780	950	1150	1450	1750
GG	1.6	2.2	2.6	3.1	3.9	5.6	7.6
HJ, HL	2	2.8	3.4	4.5	6.2	9.5	13.5
AS, AK, AL	2.8	3.9	5.5	7.7	11.2	16.8	—

Note: NPSH_R – FEET OF LIQUID (Specific Gravity 1.0), Viscosities up to 750 SSU

AUSTRALIAN DISTRIBUTOR



CALL 1300 789 466

When Pump Knowledge Matters

www.kelairpumps.com.au