

MOTOR SPEED PRODUCT LINE: CAST IRON PUMPS

SERIES 456

Section	1442
Page	1442.1
Issue	D

TABLE OF CONTENTS

Features & Benefits	2
Standard Materials of Construction	2
Specifications	2
Model Number Key	3
Cutaway View & Pump Features	3
Dimensions – C, F, FH Sizes	4
Dimensions – C, F, FH Sizes – M Drive	4
NPSH Required	5

SERIES DESCRIPTION

The 456 Motor Mounted units answer the need for more compact, lighter weight equipment. They use the Series 456 hub type pumps with valves in casings and are mounted to modified NEMA “C” flange motors. Units are available with ¼, ⅓, ½ or ¾ HP, 1 ph, 1200 RPM or 1800 RPM, special shaft, TEFC or explosion proof motors. All sizes use the mounting flange bracket with pump connected to motor through a coupling. The pump can be turned on the bracket to any position desired. Series 456 pump models are available with Underwriters label (UL343) for handling fuel oil. Model numbers for these pumps must be designated by a suffix -X. “UL” listed models must be equipped with integral relief valve.

RELATED PRODUCTS

Cast Iron, 32 & 432 Series: Catalog Section 310



FH456

OPERATING RANGE

SERIES	NOMINAL FLOW		MAXIMUM PRESSURE*		TEMPERATURE RANGE		VISCOSITY RANGE*	
	GPM	m ³ h	PSI	Bar	°F	°C	SSU	cSt
456	0.5 - 3	0.1 - 0.7	250	17	-60 to +350	-50 to +175	28 to 7,500	1 to 1,650

- 250 PSI for 100 SSU & above, 100 PSI for less than 100 SSU

Section	1442
Page	1442.2
Issue	D

MOTOR SPEED PRODUCT LINE: CAST IRON PUMPS SERIES 456

FEATURES & BENEFITS

- Relief Valve Standard
 - » Permits bypassing of liquid from discharge back to suction side of pump. Prevents building up excessive pressure in discharge line. If reversing pump at any time, valve parts must be inserted in opposite port. Pumps with relief valve are built with right hand suction as standard.
- Mechanical Seal
 - » All models are furnished with mechanical seal. The seal is a rotary type packaged unit that is simple and self-adjusting.

STANDARD MATERIALS OF CONSTRUCTION

Component	Standard Material
Casing	Cast Iron, ASTM A48, Class 35B
Head	Cast Iron, ASTM A48, Class 35B
Rotor & Shaft	Steel (C Size) ASTM A311, Grade 1144, Class B (F-FH Size)
Idler	Powdered metal, MPIF 35, FLC-4608-75HT
Idler Pin	Nitralloy, MIL-S-6709
Casing Bushing	Carbon Graphite
Mechanical Seal	Buna-N, FKM, Carbon vs. Ni-Resist

SPECIFICATIONS

Model Number	Port Size	Nominal Pump Rating (100 SSU & below)			Maximum Recommended Discharge Pressure (PSIG)			① Maximum Recommended Temperature		Maximum Hydrostatic Pressure		② Approximate Pump Shipping Weight with Valve and With Motor	
		GPM	m ³ /h	RPM	Less Than 100 SSU	Fuel Oil Less Than 100 SSU	100 SSU and Up	°F	°C	PSIG	BAR	Lbs.	Kg.
C456	¼	0.5	0.1	1750	100	150	250	225	107	750	51	42	19
F456	½	1.5	0.3	1750	100	150	250	225	107	750	51	43	19.5
FH456	½	3	0.7	1750	100	150	250	225	107	750	51	44	20

① Temperatures to 350°F (180°C) can be handled with special construction.

② Includes ½ HP, 1 PH. TEFC motor.

**MOTOR SPEED PRODUCT LINE:
CAST IRON PUMPS**
SERIES 456

Section	1442
Page	1442.3
Issue	D

MODEL NUMBER KEY

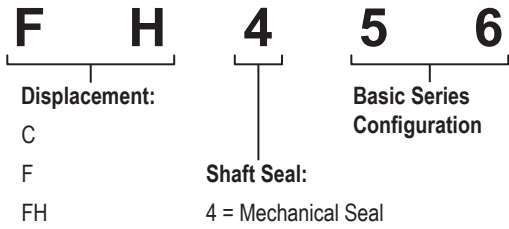

CUTAWAY VIEW & PUMP FEATURES

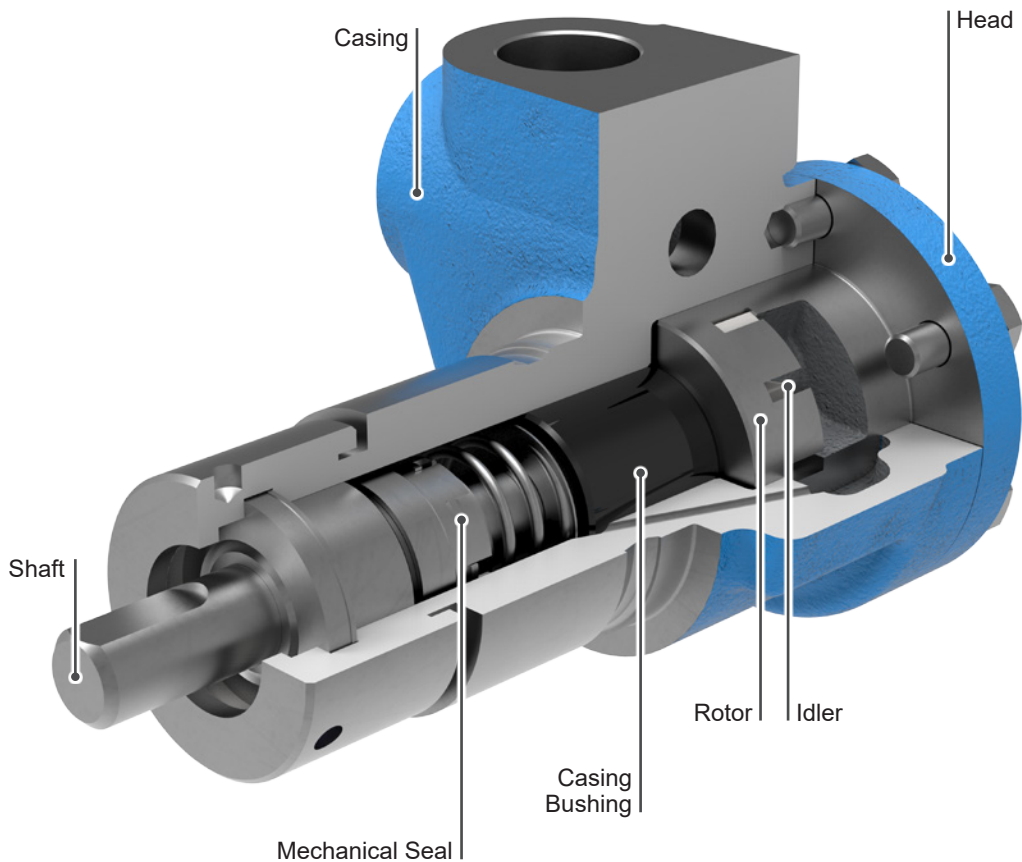

Section	1442
Page	1442.4
Issue	D

**MOTOR SPEED PRODUCT LINE:
CAST IRON PUMPS
SERIES 456**

DIMENSIONS – C, F, FH SIZES

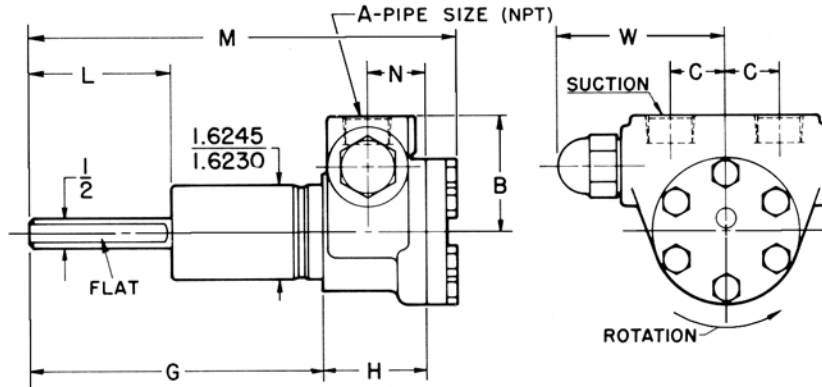

Model Number	A (in)		B	C	G ₁ ①	G ₂ ②	H	L	M ₁ ①	M ₂ ②	N	W
C456	¼	in	1.69	0.75	3.38	4.66	1.47	2.25	5.38	6.69	0.88	2.56
		mm	43	19	86	118	37	57	137	170	22	65
F456	½	in	2.00	0.94	3.38	4.59	1.84	2.00	5.75	7.00	1.00	2.88
		mm	51	24	86	117	47	51	146	178	25	73
FH456	½	in	2.00	0.94	3.38	4.97	1.84	2.38	5.75	7.38	1.00	2.88
		mm	51	24	86	126	47	60	146	187	25	73

① G₁ & M₁ for 456 models for M mount. These pumps have a 37/8" shaft.

② G₂ & M₂ for 456 models with 57/8" shaft. These pumps cannot be M mounted.

DIMENSIONS – C, F, FH SIZES – M DRIVE

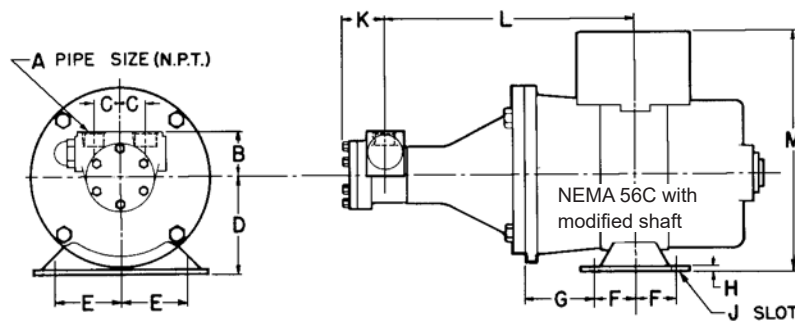

Model Number	A (in)		B	C	D	E	F	G	H	J	K	L	M
C456	¼	in	1.69	0.75	3.50	2.44	1.50	2.56	0.13	0.34	1.44	8.97	9.00
		mm	43	19	89	62	38	65	3	9	37	228	229
F456	½	in	2.00	0.94	3.50	2.44	1.50	2.56	0.13	0.34	1.56	9.22	9.00
		mm	51	24	89	62	38	65	3	9	40	234	229
FH456	½	in	2.00	0.94	3.50	2.44	1.50	2.56	0.13	0.34	1.56	9.22	9.00
		mm	51	24	89	62	38	65	3	9	40	234	229

These dimensions are average and not for construction purposes. Certified prints on request.

**MOTOR SPEED PRODUCT LINE:
CAST IRON PUMPS
SERIES 456**

Section	1442
Page	1442.5
Issue	D

NPSH REQUIRED

Printed performance curves are not available.

Performance curves can be electronically generated with the Viking Pump Curve Generator on vikingpump.com.

NPSH_R data is not available on the curve generator.

NPSH (Net Positive Suction Head): The NPSH_R (Net Positive Suction Head Required by the pump) is given in the table below and applies for viscosities through 750 SSU. NPSH_A (Net Positive Suction Head – Available in the system) must be greater than the NPSH_R. For a complete explanation of NPSH, see Application Data Sheet AD-19.

FOR VISCOSITIES UP TO 750 SSU – See NPSH_R table below.

NPSH_R for high viscosities can be estimated using the following method:

1. Calculate line loss for a 1 foot long pipe of a diameter matching the pump inlet port size. Use your flow rate and max viscosity.
2. Convert this value into Feet of Liquid (S.G. 1.0)
3. Add this value to the NPSH_R value in the chart below.

NPSH_R – FEET OF LIQUID (Specific Gravity 1.0), Viscosities up to 750 SSU

PUMP SIZE	PUMPS SPEED, RPM					
	640	780	950	1150	1450	1750
C	—	—	1.7	1.9	2.2	2.4
F, FH	1.8	1.9	2.1	2.3	2.8	3.4

AUSTRALIAN DISTRIBUTOR



CALL 1300 789 466

When Pump Knowledge Matters

www.kelairpumps.com.au